



#61-080

#61-076

#61-067

#61-065

***Vol-Con[®] Voltage/
Continuity Tester***

(61-080, 61-076)

Vol-Test[™] Voltage Tester

(61-067, 61-065)

Instruction Manual Read First:

Safety Information Understand and follow  rating instructions carefully. Use the tester and test leads only as specified in this manual; otherwise, the protection provided by the tester can be impaired.

  **WARNING**

To avoid possible electric shock, personal injury or death, follow these guidelines:

- Do not use if tester appears damaged. Visually inspect the tester to ensure case and is not cracked.
- Inspect and replace test leads if insulation is damaged, metal is exposed, or probes are cracked. Pay particular attention to the insulation surrounding the connectors.
- Always ensure the tester, test leads and all accessories meet or exceed the measurement category required in the working environment. (i.e. CAT rating)
- Note that the measurement category and voltage rating of combinations of the tester, the test leads, and the accessories is the lowest of the individual components.
- Do not use tester if it operates abnormally as protection maybe impaired.
- Do not use during electrical storms or in wet weather.

- Do not use around explosive gas, dust, vapor, amperage or in damp or wet environments.
- Do not apply more than the rated voltage to the tester.
- Remove the test leads from the input jacks before measuring current.
- Remove the test leads from the meter prior to removing battery cover. (61-076, 61-080)
- Do not use without the battery and battery cover properly installed. (61-076, 61-080)
- Do not attempt to repair this unit as it has no user-serviceable parts.
- Never ground yourself when taking electrical measurements.
- Connect the black common lead to ground or neutral before applying the red test lead to potential voltage. Disconnect the red test lead from the voltage first.
- Keep fingers behind the guard rings of the probe tips.
- Voltages exceeding 30VAC or 60VDC pose a shock hazard so use caution.



CAUTION

To protect yourself, think “Safety First”:

- Comply with local and national safety codes.
- Use appropriate personal protective equipment such as face shields, insulating gloves, insulating boots, and/or insulating mats.
- Before each use:
 - Perform a continuity test by touching the test leads together to verify the functionality of the battery and test leads.
 - Use the 3 Point Safety Method. (1) Verify meter operation by measuring a known voltage. (2) Apply meter to circuit under test. (3) Return to the known live voltage again to ensure proper operation.
- Always work with a partner.

Features:

- Vibration Mode with indicator movement
- Auto-Switching Voltage/Continuity Technology (61-076, 61-080)
- Independent solenoid and electronic circuitry design provides back-up voltage indication for added safety
- Low Impedance
- Replaceable Test Leads
- Shielded probe tips
- Ultrasonically welded and o-ring sealed for added durability
- Indicates:
 - 100-600V AC/DC (61-065, 61-067)
 - 5-600V AC/DC (61-076, 61-080)

To Measure AC/DC Voltage:

- Ensure that the plug for the test leads is fully seated into the banana jacks.
- Connect the tester in parallel with the load or circuit.
- The tester indicates the voltage type, DC polarity, and the voltage level.



Warning

Do not exceed duty cycle specified on tester.

To Test for Continuity (61-080, 61-076):

- Ensure that the plug for the test leads is fully seated into the banana jacks.
- Test for continuity by connecting the tester to the de-energized circuit.
- If circuit has $<500\text{k}\Omega$, the Continuity LED lights.
- Reversing prods on the circuit under test verifies continuity versus low voltage +DC.

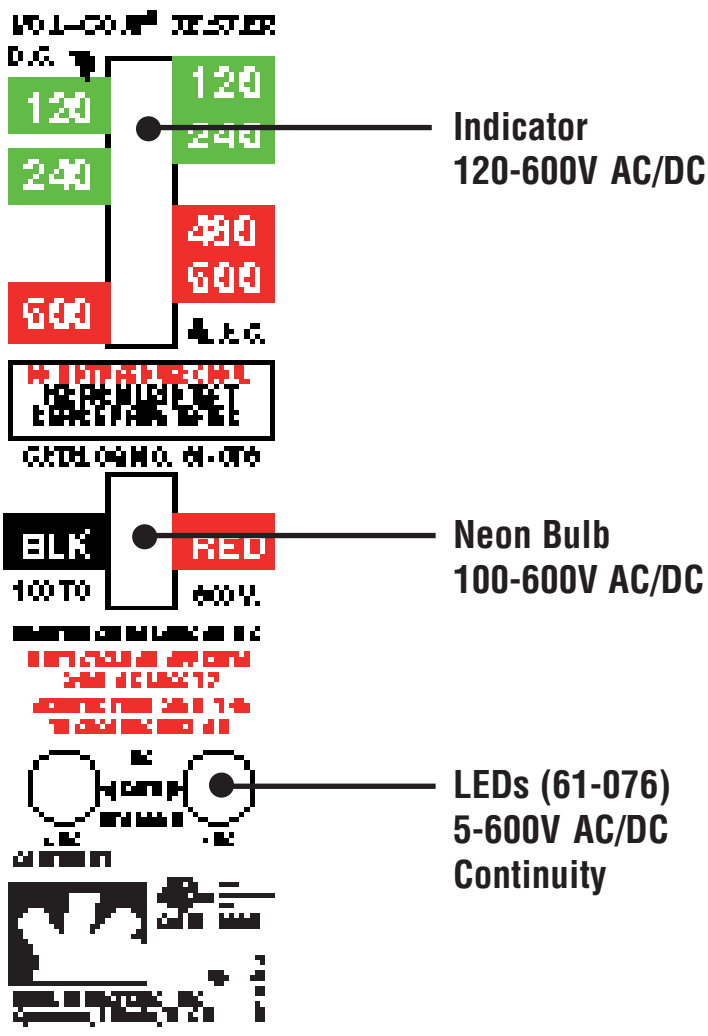

Applications:

- Locating Blown Fuses**

With power off (61-076, 61-080): Place tester across the suspected fuse to perform continuity check. If continuity LED lights, the fuse is good. If not, the fuse is defective.

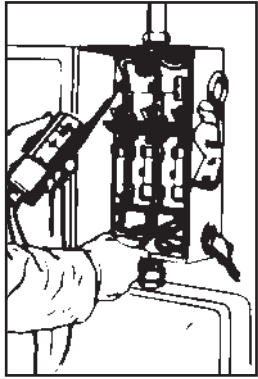

With power on: Place tester across the "source" side of one fuse and the load side of an adjoining fuse. If no or low voltage is indicated, the fuse next to the load side prod is blown. If line voltage is indicated, the fuse next to the load side prod is OK. Repeat the same test with the prods on the opposite side of the same two fuses to check the other fuse.

- **Finding Grounded Side of Line (neutral)**

Hold one test prod to the ground and touch the other test prod to each of the line terminals until one is found that does not give a voltage indication. This is the grounded side of the line.

The continuity LED should also light.

(61-080, 61-076)

- **Checking Continuity of Cords, Motors, Appliances, etc.** (61-080, 61-076)

Remove power source and place tester across circuit to be tested. Continuity LED lights if resistance is less than 500k Ω .

- **Locating Excessive Leakage to Ground**

(61-080, 61-076)

Place tester across the neutral terminal and the ground. The single continuity LED should indicate neutral and ground are connected. If both LEDs light, there is > 5VAC (N-G) indicating a high resistance leakage to ground.

Battery Replacement (61-080, 61-076):

- Replace batteries when touching the leads together no longer lights the continuity LED.
- Remove test leads from tester.
- Carefully, pry the two battery caps from the bottom of the case using a screwdriver.
- Replace the batteries.
- Snap the battery caps back in place ensuring the cap is flush with the bottom of the case.

Accessories:

- 61-070 Standard test leads (61-076, 61-065)
- 61-072 Resistor-fused test leads (61-080, 61-067)
- C-90 Soft-sided carrying case
- 61-010 Leather case

Maintenance:

- Clean the case with a damp cloth and mild detergent. Do not use abrasives or solvents.