

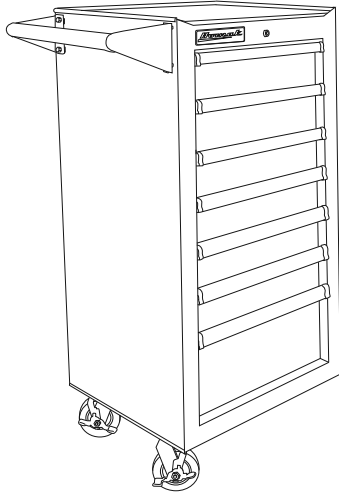

MANUAL
& OPERATING INSTRUCTIONS



MODEL
BK08018070 - BLACK

18" H2Pro SERIES 7 DRAWER SIDE CABINET



WARNING:

1. Close and lock drawers before moving.
2. Do not stand on the product. You may fall which may cause personal injury.
3. Do not climb on, in or around. Keep away from children.
4. Unit has a maximum load capacity of 800 lbs (363.6 kg). Do not overload.
5. Do not step in the drawers. You may fall which may cause personal injury.
6. Read all instructions and safety tips before using this product.
7. For indoor use only.

THANK YOU FOR PURCHASING A HOMAK UNIT. WE APPRECIATE YOUR BUSINESS.

Congratulations on your new purchase!

Before operating your unit, please read the following carefully:

**KEEP INSTRUCTION MANUAL IN A SAFE PLACE UPON OPENING YOUR NEW UNIT.
THE KEY CODE TO YOUR HMC SECURE PREMIUM TUBULAR LOCK CAN BE
FOUND ON THE BACK OF THIS MANUAL.**

PARTS LIST:

- A) Top Mat & Drawer Liners
- B) Keys
- C) 2 Caster Attachment Plates
- D) 2 Swivel Locking Casters
- E) 16 Bolts, 16 Lock Washers & 16 Washers for Casters & Caster Attachment Plates
- F) 36" & 41" H2Pro Series rolling cabinet attachment plate
- G) 56" H2Pro Series rolling cabinet attachment plate
- H) 72" H2Pro Series rolling cabinet attachment plate
- I) 4 Screws to Secure Rolling Cabinet Attachment Plate
- J) 4 nuts for securing side cabinet to rolling cabinet attachment plate

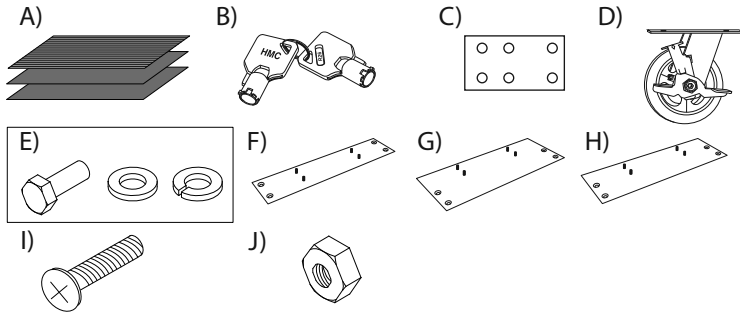

MOUNTING THE SIDE CABINET TO THE ROLLER CABINETS



*Work with a 2 person team to assemble this product to avoid personal injury.

1) Remove the top two drawers and slides as shown in the drawer removal instructions on the following page.

2) Turn side cabinet on its side. Make sure to lay down protective material (such as the cardboard packaging that came with the side cabinet) in order to prevent damage to the side cabinet while installing casters.

3) Using 8 bolts, 8 lock washers and 8 washers (Part E), secure the 2 caster attachment plates (Part C) to the side cabinet on the side that will be facing the rolling cabinet.

4) Attach 2 casters (Part D) to opposite side of side cabinet using 8 bolts, 8 lock washers and 8 washers (Part E).

5) Remove push handle from rolling cabinet.

6) Screw the appropriate rolling cabinet attachment plate (Part F, G, or H) to the rolling cabinet using the 4 screws provided (Part I).

7) Remove 4 bolts, washers, and lock washers on outer edge of rolling cabinet casters.

8) For the following steps: do not tighten bolts until all hardware is properly aligned, then tighten fully.

9) Use 4 nuts (Part J) to secure side cabinet to rolling cabinet attachment plate as shown in the diagram below.

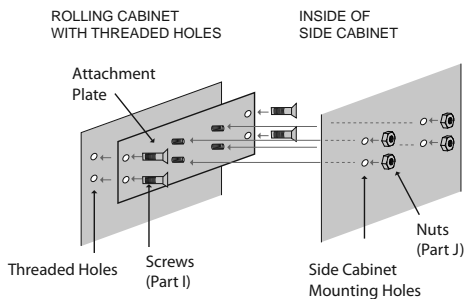

10) Secure caster attachment plates to the rolling cabinet casters using the rolling cabinet caster hardware that was removed in Step #6.

11) After all attachments are secure, fully tighten all bolts.

DRAWER AND BEARING REMOVAL:

To remove drawers and slides, pull drawer all the way out, depress the black drawer release levers on each slide. For ball-bearing glides, there is one black lever per slide. One black lever will be pushed down and the other will be pushed up for drawer removal. After levers are pushed, the drawer is released. Pull out drawer all the way for removal. To re-install the drawer, line up cabinet glides to drawer glides and squeeze glides inwards while pushing in the drawer until each glide “clicks” into place.

After drawer removal, push up on the front of the ball-bearing drawer glide. After front of glide is free from unit, pull the drawer glide slightly away from inner wall of cabinet. Gently pull the ball-bearing glides straight out of unit for full removal.

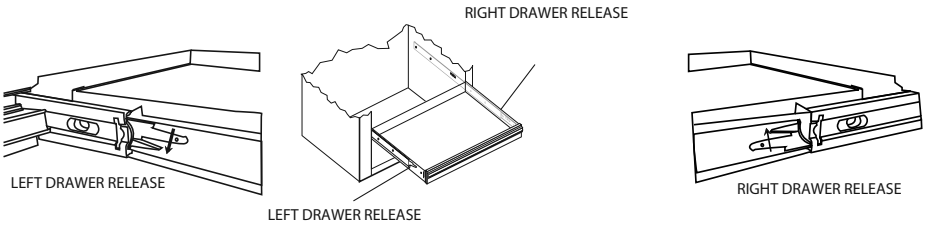

BEARING REMOVAL:

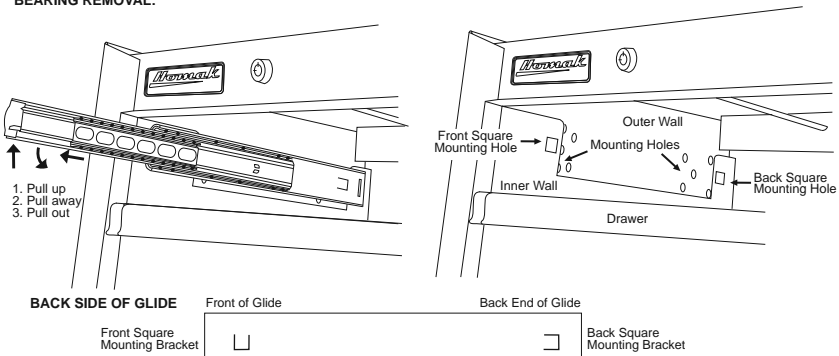

MAINTENANCE

Ball-Bearing Slides

To maintain the smooth and quiet operation of the ball-bearing slides, lubricate the extension track that houses the ball bearings every 3-6 months with a high quality jelly-like petroleum based lubricant.

Powder Coat Finish

For heavy build-up of dirt and grime, our powder coat paint finish can be cleaned with spray wax. Lightly spray the wax on the surface, and gently wipe with a soft, dry microfiber cloth. Window cleaner and a soft cloth dampened with water can be used to clean the finish on a regular basis.

Customer Satisfaction

All mechanical parts are inspected and adjusted for proper use before shipment; however, mechanisms such as drawer slides and locks may shift during transit.