



Strong, Reliable Support with

Carts & Stands

Enabling shops to make the most of their limited space, Herkules Carts and Stands provide space-saving, heavy-duty storage tools that improve both productivity and ergonomics.

Powerful lifting capabilities, solid construction and protected surfaces make Herkules Carts and Stands ideal for shops. Whether mounted to the floor or wall, utilizing heavy-duty wheels or quick-fold storage, Herkules Carts and Stands provide accessibility and greater flexibility to shop tools and processes with dependable and reliable support.

Most Herkules Carts & Stands are built in Walled Lake, Michigan.



Support Shop Processes with Powerful,

Simplify Door and Bumper Installs with DJ5020

Mounting a door or bumper becomes a one-person job with the DJ 5020 Door & Bumper Jack.

With a 200 lb. lift capacity, heavy parts can be safely held at the desired height for proper mounting.

Equipped with 4 caster wheels for easy movement, leveling rods for precise placement, and an easy-turn handle for positioning, this jack simplifies installation and reduces worker strain.



Heavy-Duty & Portable Storage Made Easy

The Herkules PartsMobile easily handles, stores and even moves heavy doors and panels.

Available with four or two shelves, the PartsMobile has two fixed and two swivel wheels for easy mobility, and is constructed of tubular steel and flat steel shelves.

PartsMobiles are 22" deep by 48" wide and 68" high. The Parts Mobile 1 (PM1) offers four solid platform shelves, each with a 200 lbs. load capacity. Three shelves provide a 1" deep edge to help collect rolling parts. An additional shelf provides two removable trays for holding small parts. Eight S-hooks and three removable pegs are included.

Parts Mobile 2 (PM2) offers two (2) sturdy solid platform shelves, each with a 200 lbs. load capacity, with the middle shelf providing a 1" deep edge.

PM1



Protects Parts, Increase Access with the Flexi-Table

The Herkules Flexi-Table easily and safely holds panels, doors, hoods, bumpers, windshields and accessories in place. The release pin enables quick and easy position changes, with multiple position options available.

Rubber-coated, removable pegs protect parts, and keep them in place. The Flexi-Table folds for easy storage, measures 30 deep" x 38 wide" x 35" high, has a 500 lb. lift capacity, and is made in USA.

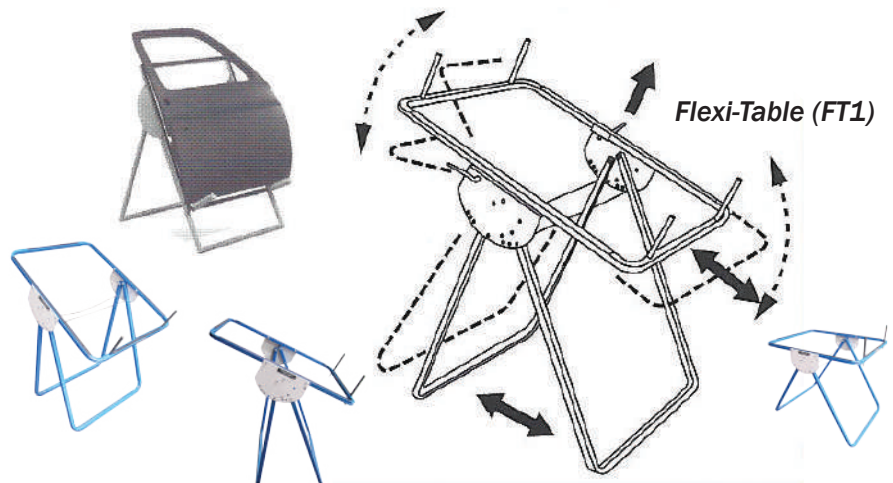

and Portable, Products

Increase Accessibility with Vise and Grinder Stands



Vise and Grinder Floor Stand (VGF1)

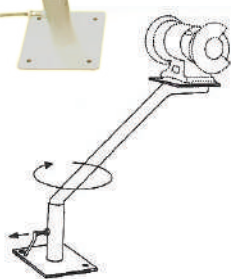

Vise and Grinder Wall Stand (VGW1)

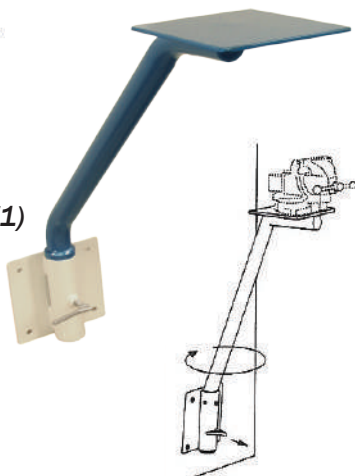

Tools once buried in bench clutter are given great access and versatility with Herkules Vise and Grinder Stands. These stands can be mounted to the wall or floor, giving greater access to vises, grinders or any shop tool that can safely fit on the 8" by 8" plate.

Floor-mounted, the Herkules Vise and Grinder Floor Stand (VGF) can swivel up to 360° for ultimate flexibility.

Mounted to the wall, the Herkules Vise & Grinder Wall Stand (VGW1) has less range of motion, yet provides great accessibility and flexibility of use.

Both stands can be locked in any position.



X-Stand Provides Support Anywhere in the Shop

Easy to set up, easy to store, the Herkules XT-500 X-Stand is adjustable—from 24" high x 39" wide to 44" high x 18" wide. Made with powder-coated steel tubing and dual safety chains for solid positioning, the XT-500 also provides polyfoam covers to protect the work piece. Lightweight for easy storage, the X-Stand has a 500 lbs. capacity.



"X"Stand (XT-500)





Carts and Stands Comparison Chart

Whatever type of handling support you need, Herkules has it -- heavy duty, portable carts to strong and flexible stands.

	DJ5020 Door & Bumper Jack	FT1 Flexi-Table	PM1 PartsMobile 1	PM2 PartsMobile2	VGf &Grinder Vise & Floor Stand	VGW - Vise & Grinder Wall Stand	XT500 X-Stand Work Stand
Weight capacity	200 lbs	500 lbs	800 lbs	600 lbs	150 lbs	150 lbs	500 lbs
Size (dimensions)	24.25" d x 24"w x 41"h	30"d x 38"w x 35"h	22"d 48"w 68" h	22"d 48"w 68" h	34" high; base plate 8" X 8" x 1/4"	34" high; base plate 8" X 8" x 1/4"	24"h x 39"w to 44"h x 18 w
Adjustable	Y	Y	N	N	Y	Y	Y
Foldable	N	Y	N	N	N	N	Y
Portable	Y	Y	Y	Y	N	N	Y
Floor mount	N	N	N	N	Y	Y	N
Wall mount	N	N	N	N	N	Y	N
Designed to hold	Doors & bumpers	Panels, doors, hoods, accessories	Doors, fenders & panels, small parts	Doors, fenders & panels, small parts	Vise, grinder or anything under 150 lbs that can be bolted to the platform	Vise, grinder or anything under 150 lbs that can be bolted to the platform	Doors, panels, anything under 500 lbs that fits

Discover other power grinders and rotary tools on our website.