

Model: HCR3

OWNERS MANUAL



INSTRUCTIONS

This manual contains important information concerning the installation and operation of the crusher listed above.
Read manual thoroughly and keep for future reference

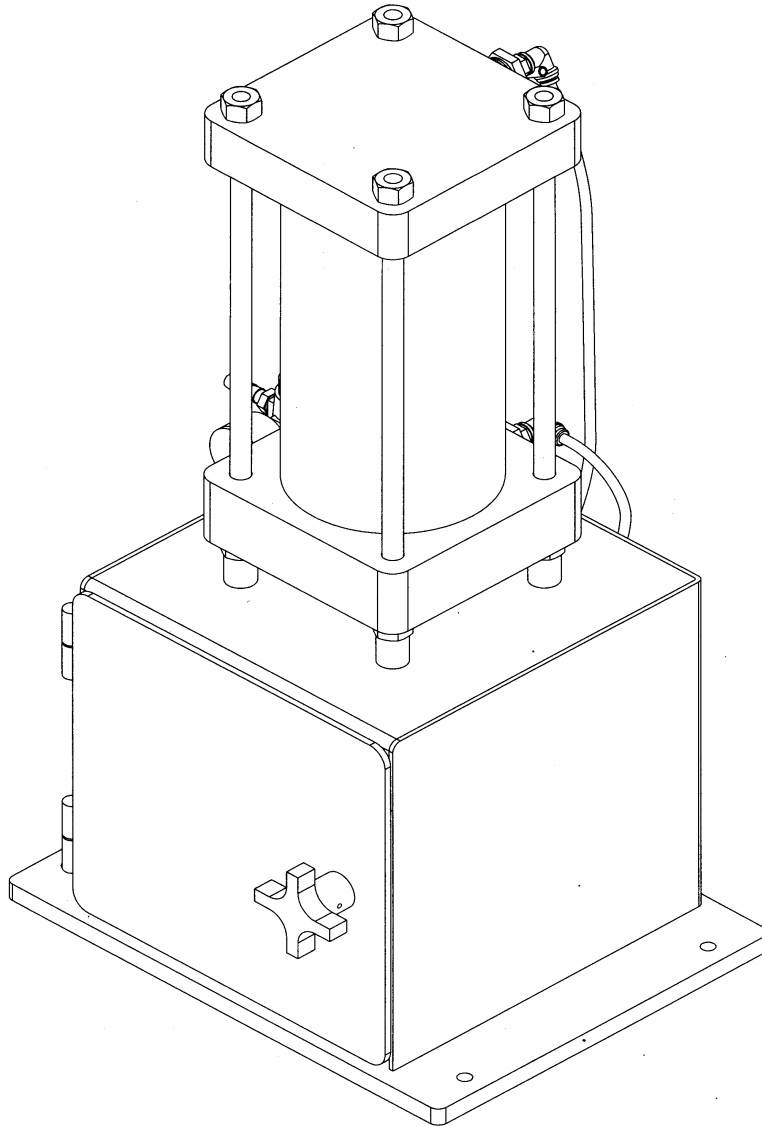

Table of Contents

Warnings	3
Model Information	4
Installation	5
Inspection	6
Operation	6
Maintenance	7
Repair	7
Drawings with part callouts:	7-8

Warning Symbol



This symbol alerts you to the possibility of serious injury or death if you do not follow the instructions.

Caution Symbol



This symbol alerts you to the possibility of damage to or destruction of equipment if you do not follow the instructions.



WARNING

FAILURE TO HEED THE FOLLOWING WARNINGS MAY RESULT IN PERSONAL INJURY AND/OR PROPERTY DAMAGE.

- 1 Herkules will not be held responsible for any personal injury and/or property damaged caused due to owner/operator failure to follow the warnings and cautions listed in this manual.
- 2 Read and understand all warnings, cautions and instructions before operating this equipment.
- 3 It is the owner/operator's responsibility to maintain the legibility of all warning and instruction labels.
- 4 Do not alter or modify any part of this equipment.
- 5 Do not attempt to bypass the door/latch interlock system. The door interlock is provided for operator safety.
- 6 DO NOT open the door while the unit is operating. Always wait for the crusher to cycle completely.
- 7 Crush only intended matter for the crusher.
- 8 Always wear safety glasses when operating the crusher.
- 9 Always wear suitable industrial gloves when handling crushed objects to prevent injury.
- 10 Check equipment regularly for proper operation and repair or replace worn or damaged parts immediately.
- 11 Any crusher that appears to be damaged in any way, is badly worn or operates abnormally shall be removed from use until repairs are made. Use only manufacture's approved accessories and service parts. Contact a factory authorized service center for repairs.
- 12 DO NOT REMOVE THIS LABEL. REPLACE IF DAMAGED.

Model Information

SPECIFICATIONS

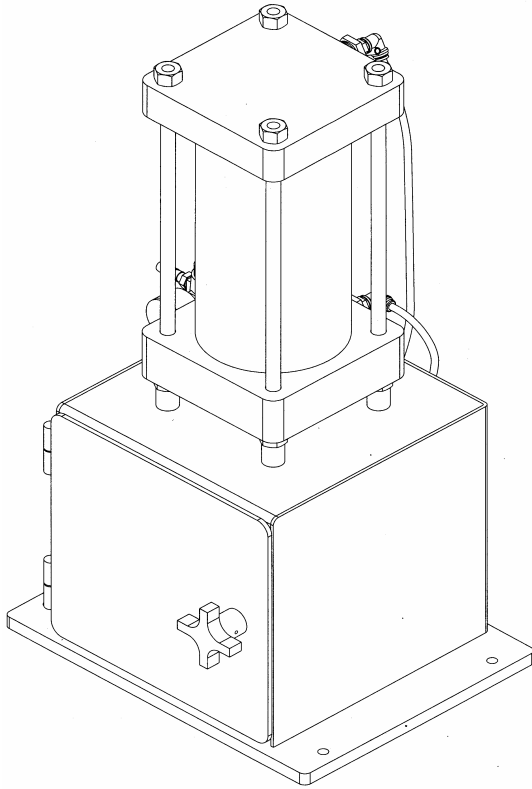

Maximum crushing pressure	2.1 tons
Can capacity	One 1-gallon can Three 1-quart cans
Time to crush can	20 seconds
Overall width	18.125"
Overall height	25.25"
Overall depth	13.5"
Chamber width	10"
Chamber height	10"
Chamber depth	10"
Required air pressure	90-120 p.s.i.
Total weight	75 lbs.

OWNER/OPERATOR RESPONSIBILITY

It is the owner/operator's responsibility to properly use and maintain this equipment.

The instructions and warnings contained in this manual shall be read and understood by the owner/operator prior to operating this equipment.

If an owner/operator does not understand English, the contents of this manual shall be explained in the owner/operator native language to assure the owner/operator comprehends.

It is the owner/operator's responsibility to maintain the legibility of all warning and Instruction labels.

The owner/operator shall retain this manual for future reference to important warnings, operating and maintenance instructions.

INSTALLATION

See figures 1 & 2. Install the crusher as follows.

Step 1

Set the unit on a bench or table that can support its weight. It is recommended that the unit be lagged or bolted down.

Step 2

Assemble the oiler to the valve using (1) 1/4 NPT hex nipple.

Note: Arrow on oiler must point towards the valve

Step 3

Assemble the air pressure gauge to the filter/regulator by first removing the plug on the side with the arrow pointing from left to right.

Step 4

Assemble the filter/regulator to the oiler using (1) 1/4 NPT hex nipple.

Note: Arrow on filter/regulator must point towards the valve

Step 5

Fill the oiler with 30W non-detergent oil

Note: Set to about 1/3 of max drip rate. Lower drip rate if cylinder is leaking oil.

Step 6

Attach the provided hose barb to the filter/regulator.

Step 7

Connect air supply to the hose barb.

Note: Air supply should not exceed 120 psi.

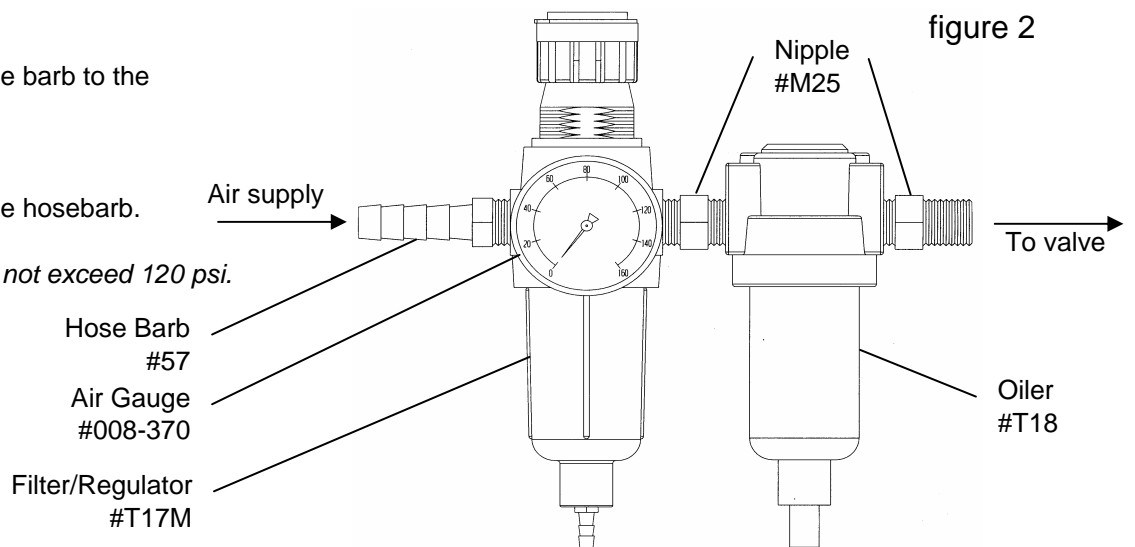

figure 1

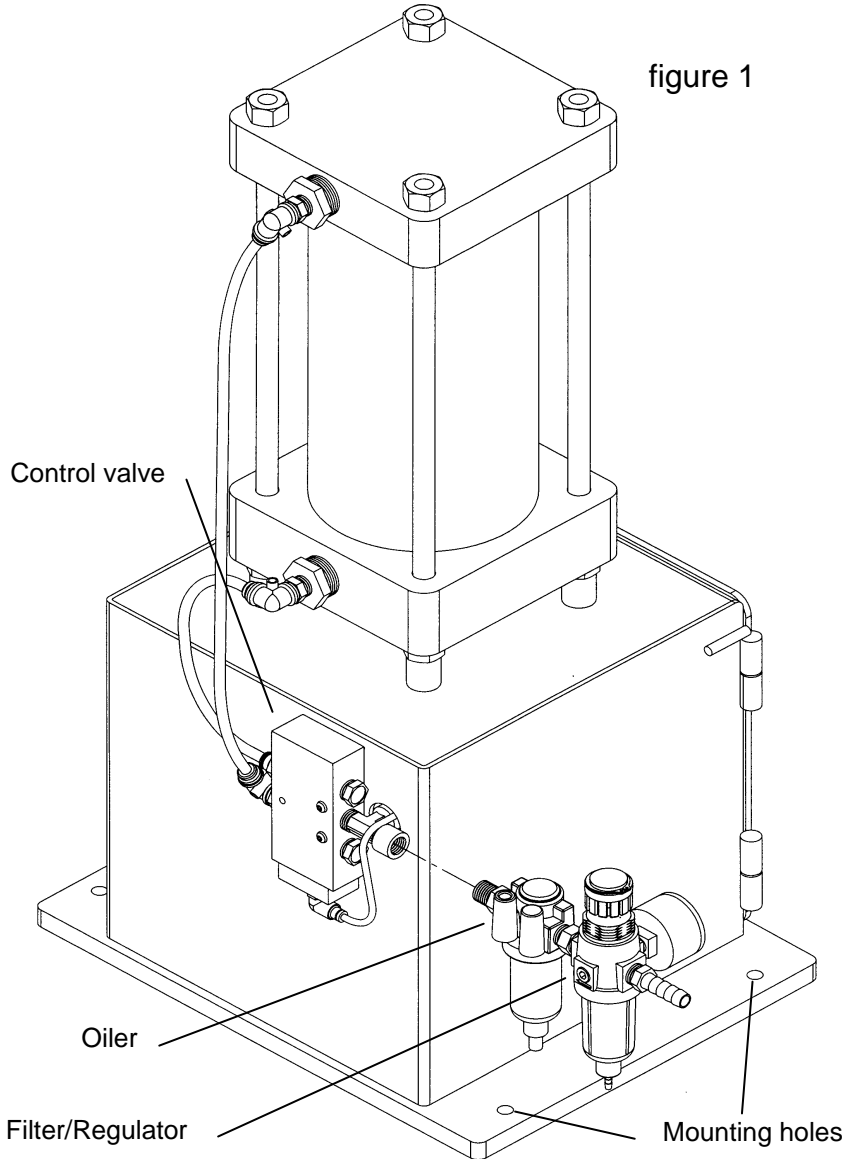

figure 2

INSPECTION

Prior to operation a visual Inspection shall be made. Check crusher for leaks, worn or missing parts.

Periodically check oil level of oiler. **DO NOT RUN WITHOUT OIL.**

Any crusher that appears to be damaged in any way, is badly worn or operates abnormally shall be removed from use until repairs are made. Contact a factory authorized service center for repairs.

If over pressurizing of the equipment is believed to have occurred, contact a factory authorized service center for inspection of the crusher.

An annual inspection by a factory authorized service center is recommended.

OPERATION

- 1) Turn the external air supply on.
- 2) Verify the pressure gauge on the pressure regulator/filter reads between 100 and 120 p.s.i. Adjust the regulator as required.

Note:

If the external air supply is less than 100 psi, the crusher will operate but the crushing performance is reduced.

- 3) Open door and place empty can in center of chamber.

Note:

For a gallon can, use the centering rods on the base plate for proper placement.

- 4) Close the door and latch it firmly.
- 5) The pneumatic piston will descend to crush the can. At the end of the crushing cycle open the door to remove the crushed can.

WARNING

The crushing mandrel may be still moving when the door is opened. Wait until the mandrel stops before placing hand in chamber.

- 6) Once the crushing plate has stopped moving, remove the crushed cans from the crushing chamber.

WARNING

A crushed can may have jagged metal edges. Use industrial work gloves to protect operator's hands when handling a crushed can.

- 7) **IMPORTANT!! LEAVE THE DOOR AJAR WHEN NOT IN USE.**

DISCLAIMER

Remove all solvents from cans prior to crushing.

SAFETY INFORMATION

Read and understand all warnings, cautions and instructions before operating this equipment. Caution should be used when operating this equipment as personal injury and/or property damage can result from equipment misuse. Adequate personal protection is recommended to prevent splashing of fluids on the skin or in the eyes.

MAINTENANCE

Regularly check the pressure filter/regulator moisture trap for water. Drain as required.

Periodically check oil level in oiler. Fill to 3/4 full with 30W non-detergent oil when necessary.

DO NOT RUN WITHOUT OIL.

Regularly clean the crusher chamber to remove any accumulated sludge, metal particles or any other debris that could affect the crusher operation.

Apply grease to door hinges on a regular basis to prevent the door from binding.

Apply motor oil to door latch pivot points on a regular basis to prevent latch from binding.

REPAIR

No service parts are available for this can crusher. Special tools and procedures are required for repair. If repair is required, contact Herkules Equipment Corporation Customer Service, (800-444-4351) for your nearest authorized service center.

AIR SCHEMATIC

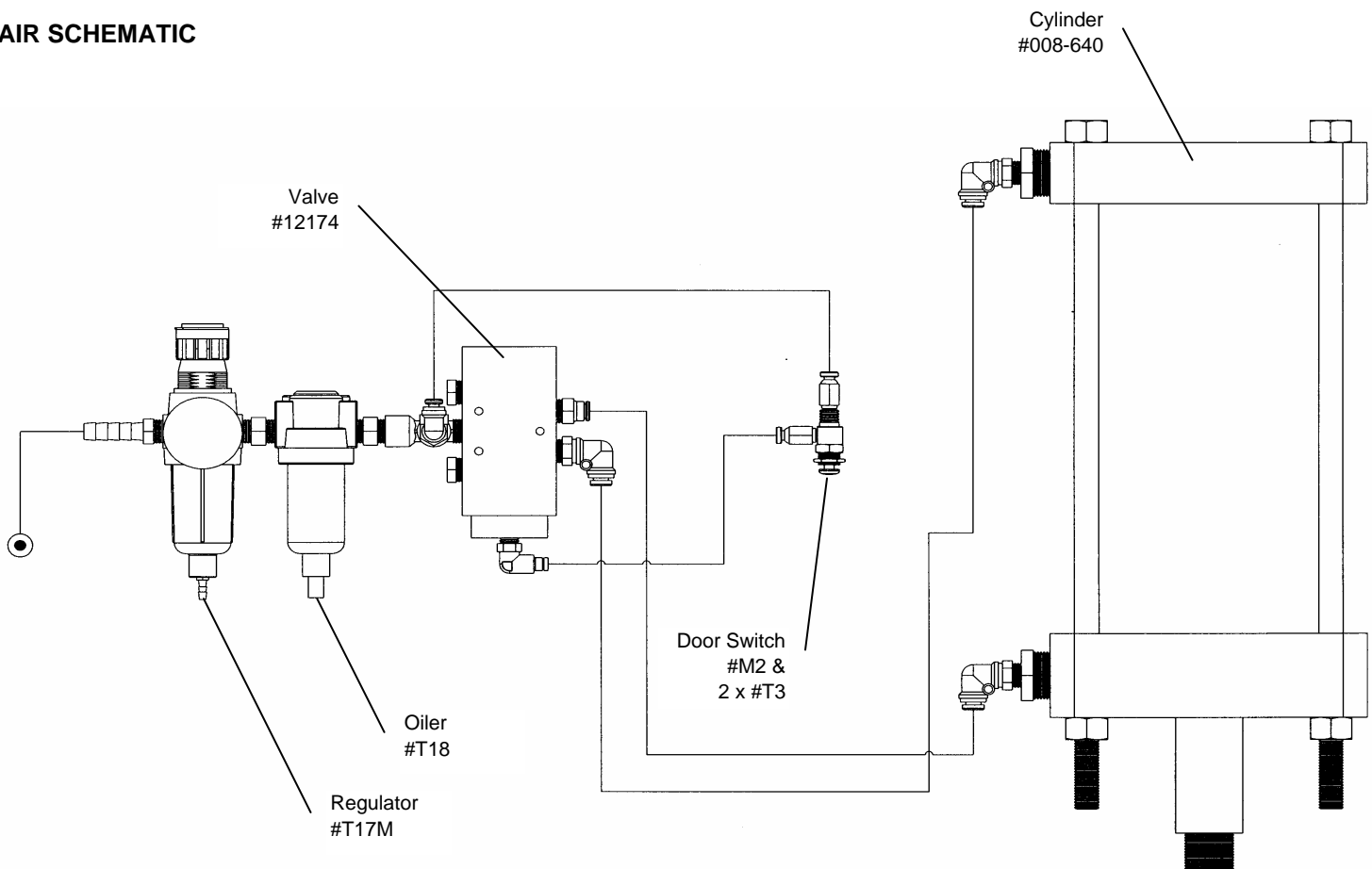

SERVICE PARTS

