

20 GPM (76 L/min) 12V (dc) Fuel Transfer Pump

**Models G20-012PX, G20-012MD, G20-012AD
(PATENT-PENDING)**

BEFORE YOU BEGIN

Fueling Requirements

- This fuel pump is designed, tested and approved for use with gasoline blends (up to E15), diesel fuel blends (up to B20) and kerosene. Please take all due precautions when handling these flammable liquids.
- Do not use this pump for dispensing any fluids other than those for which it was designed. To do so may damage the pumps components and will void the warranty.



Power Source Requirements

- This manual covers 12V (dc) electric gear pump models G20-012PX, G20-012MD, and G20-012AD
- Do not attempt connection of any pump to a 24V (dc), 115V (ac) or 230V (ac) power source.



Tools Needed

- Adjustable Wrench, Pipe Wrench, Pliers, Utility Knife, Wire Crimper/Stripper, and Metric Hex Wrenches (Hex Key) (4 & 5 mm - Included)

UNPACKING



Contents

- (1) 12V (dc) Fuel Transfer Pump
- (1) Lockable Nozzle Holder
- (1) 90-Degree Modular Fitting and hardware kit & (1) thread tape
- (1) 18 ft. (5.5 m) Power Cord (Attached on models G20-012MD & G20-012AD only)
- (1) Automatic Diesel Shut-off Nozzle (Model G20-012AD only) or Manual Diesel Shut-off Nozzle (Model G20-012MD only)
- (1) 14 ft. (4.2 m) Dispensing Hose (Models G20-012MD & G20-012AD only)
- (1) 15 in. (38 cm) to 40 in. (101 cm) Adjustable Suction Pipe (Models G20-012MD & G20-012AD only)



Inspect

- After unpacking the unit, inspect carefully for any damage that may have occurred during transit. Check for loose, missing or damaged parts. Shipping damage claims must be filed with carrier.
- Review General Safety Instructions and all Caution, Warning, and Danger statements as shown.





GENERAL SAFETY INSTRUCTIONS

IMPORTANT: It is your responsibility to:

- Know and follow applicable national, state and local safety codes pertaining to installing and operating electrical equipment for use with flammable liquids.
- Know and follow all safety precautions when handling petroleum fuels.
- Ensure that all equipment operators have access to adequate instructions concerning safe operating and maintenance procedures.

Observe all safety precautions concerning safe handling of petroleum fuels.

⚠ WARNING *To ensure safe operation, all fuel transfer systems must be properly grounded. Proper grounding means a continuous metal-to-metal contact from one component to the next, including tank, tank mount, pump, meter, filter, hose and nozzle. Care should be taken to ensure proper grounding during initial installation and after any service or repair procedures. For your safety, please take a moment to review the warnings below.*

⚠ DANGER *To prevent physical injury or property damage, observe precautions against fire or explosion when dispensing fuel. Do not operate the system in the presence of any source of ignition including running or hot engines, lighted tobacco products, gas or electric heaters, or any type of electronic device. A spark can ignite fuel vapors.*

⚠ DANGER *Observe precautions against electrical shock when operating the system. Serious or fatal shock can result from operating electrical equipment in damp or wet locations.*

⚠ WARNING *Inspect external pump wiring regularly to make sure it is correctly attached to the battery. To avoid electrical shock, use extra care when connecting the pump to power.*

⚠ WARNING *Avoid prolonged skin contact with petroleum fuels. Use protective goggles, gloves and aprons in case of splashing or spills. Change saturated clothing and wash skin promptly with soap and water.*

⚠ DANGER *Observe precautions against electrical shock when servicing the pump. Always disconnect power before repairing or servicing. Never apply electrical power to the system when any of the coverplates are removed.*

⚠ CAUTION *If using solvent to clean pump components or tank, observe the solvent manufacturer's recommendations for safe use and disposal.*

SPECIFICATIONS

| | G20-012PX | G20-012MD | G20-012AD |
|--------------------------|--|--|-------------------|
| Housing Material | Aluminum | | |
| Pump Rate | 20 GPM (76 L/min) | | |
| Duty Cycle | Intermittent, 30 minute ON, 30 minute OFF | | |
| Suction Lift | Up to 9 ft. (2.7 m) | | |
| Operating Temperature | -22 °F to 131 °F (-30 °C to 55 °C) | | |
| Max. Surface Temperature | 320 °F (160 °C) | | |
| Operating Pressure | 12 PSI (0.82 bar) | | |
| Input | 12V (dc) | | |
| Current Draw | 34 amps | | |
| Motor | 2000 RPM, .38 hp | | |
| Motor Approval | cULus Listed, Class I Div 1, IECEx/ATEX Zone 1 | cULus Listed, Class I Div 2 | |
| Motor Protection | 40 amp circuit breaker | | |
| Cord | N/A | 18 ft. (5.5 m) of 12 ga. | |
| Fuse | 40 amp | | |
| Inlet | 1 in. NPT | | |
| Outlet | 1 in. NPT | | |
| Hose Type | N/A | Buna-N Electrically Conductive Discharge Hose with Static Wire | |
| Hose Size | N/A | 1 in. x 14 ft. (4.2 m) | |
| Nozzle | N/A | 1 in. Manual Diesel | 1 in. Auto Diesel |



SPECIFICATIONS (CONTINUED)

G20-012PX, G20-012MD, G20-012AD

Dimensions

| | |
|---------------------|----------------------|
| A. Pump Assy Width | 9.20 in. (23.36 cm) |
| B. Pump Assy Height | 9.24 in. (23.46 cm) |
| C. Pump Assy Depth | 11.62 in. (29.51 cm) |

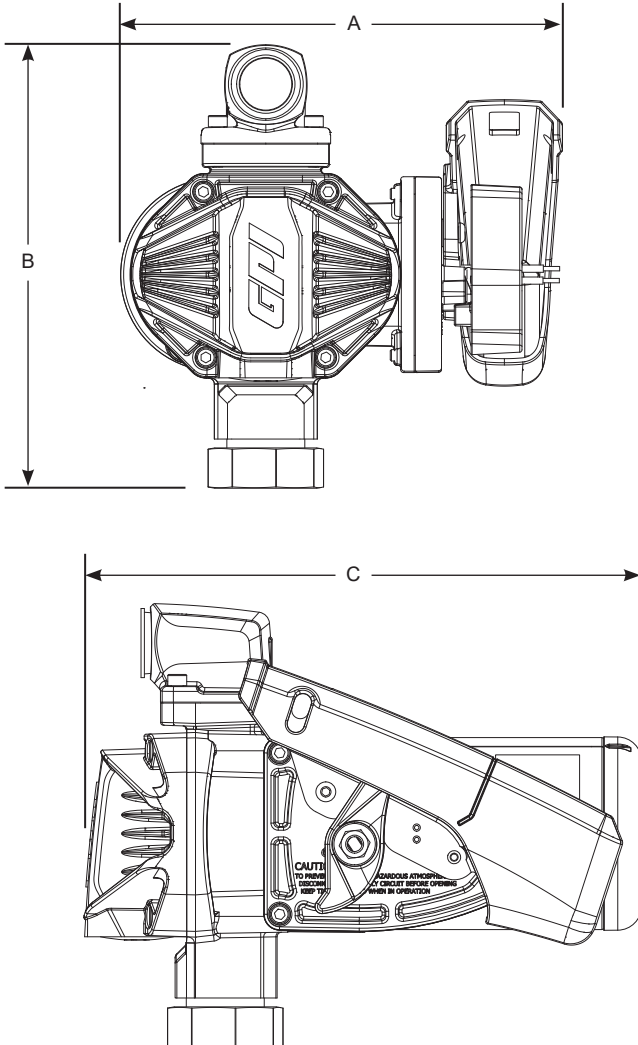

Figure 1

SPECIFICATIONS (CONTINUED)

SAFETY TESTING APPROVALS

The G20-012PX has been tested for compliance to the standards issues by Underwriters Laboratories, IECEx, and ATEX.



UL 674 (Edition 5): Electric motors and generators for use in hazardous (classified) locations.

IEC Information

Marking string:

**Ex db IIA T4 Gb
IECEx UL 19.0027X**

Standards used:

IEC 60079-0 (Edition 6.0): Explosive Atmospheres – Part 0: Equipment - General requirements.

IEC 60079-1 (Edition 7.0): Explosive Atmospheres – Part 1: Equipment protected by flameproof enclosures “d”.

IECEx specific conditions of use:

1. Flameproof joints are not intended to be repaired.
2. The special fasteners used as securing bolts for the end bell are made of Class 10.9 type fasteners. The special fasteners used for electrical cover plate attachment are made of Class A2-70 type fasteners.

ATEX Information

Marking string:

**CE₂₈₀₉ Ex II 2 G Ex db IIA T4 Gb
DEMKO 19 ATEX 2113X**

Standards used:

EN 60079-0: 2011

EN 60079-1: 2014

ATEX specific conditions of use:

1. Flameproof joints are not intended to be repaired.
2. The special fasteners used as securing bolts for the end bell are made of Class 10.9 type fasteners. The special fasteners used for electrical cover plate attachment are made of Class A2-70 type fasteners.



NOTES

GETTING STARTED

SAFETY /
SPECIFICATIONS

ASSEMBLY /
INSTALLATION

OPERATION

TROUBLESHOOTING

MAINTENANCE /
REPAIR

INSTALLATION INSTRUCTIONS

⚠ WARNING

Coverplates protect the operator from moving parts. Never operate the pump without coverplates in place. Never apply electric power to the pump without coverplates in place. Always disconnect power before repairing or servicing.

Mechanical Connections

NOTE: All threaded fuel connections must be sealed with thread tape or a pipe thread sealing compound approved for use with petroleum fuels and tightened securely to prevent leakage.

NOTE: This pump must be mounted on a vented tank.

NOTE: This pump is designed to mount directly to a standard 2 in. male pump tank mount adapter (included).

NOTE: This pump is designed to self-prime with dry gears.

If you require a greater initial prime height, coat the gears with fluid by removing the outlet fitting on the top of the pump and pour a small quantity of motor oil into the gear cavity. Replace and try again. A foot valve with pressure relief may be needed to maintain prime.

Install Tank Adapter and Suction Pipe

1. Wrap lower threaded end of the tank adapter with three or four turns of thread tape (see Figure 2). Using a wrench, tighten the adapter snugly into the fuel tank.

NOTE: For Aluminum Tank Installation - To prevent thread galling of aluminum fittings, always prepare the threads for assembly using an anti-seize compound such as Loctite® 567™, Herson® Dripstop® 940 or equivalent.

2. Using pliers, remove the plastic plug from inlet port on bottom of pump. Place the spin collar gasket into the inlet fitting on the bottom of the pump.

3. Wrap the threaded end of suction pipe with three or four turns of thread tape (see Figure 3). Thread the suction pipe into the inlet port on the bottom of the pump and hand tighten until snug.

NOTE: If your tank is 15" - 24" deep, do not use the included suction pipe extension; if your tank is 24" - 40" deep, attach the suction pipe extension (see Figure 4).

INSTALLATION INSTRUCTIONS (CONTINUED)

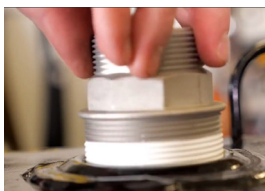

Figure 2



Figure 3

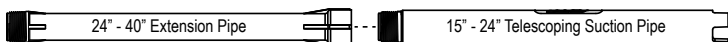

Figure 4

Install Pump on Tank

1. Clean the tank interior of all dirt and foreign material.
2. Place the pump with suction pipe installed on the tank fitting and tighten securely. Make sure the pump's spin collar is not cross-threaded.

Install Nozzle Cover

1. Using a 4mm Hex wrench, install nozzle cover using (1) M6-1.0 x 14mm BHCS in lower hole (see Figure 5).

NOTE: For model G20-012PX only, DO NOT install nozzle cover until after wiring is completed.

Install 1 in. NPT Outlet Adapter

1. Remove plastic plug from outlet port of pump.
2. Install #222 O-ring into outlet port. Make sure O-ring is seated properly.
3. Using a 5mm Hex wrench, install the (4) M6-1.0 x 20mm SHCS into the 1 in. NPT outlet adapter in desired direction on outlet port (see Figure 5).

INSTALLATION INSTRUCTIONS (CONTINUED)

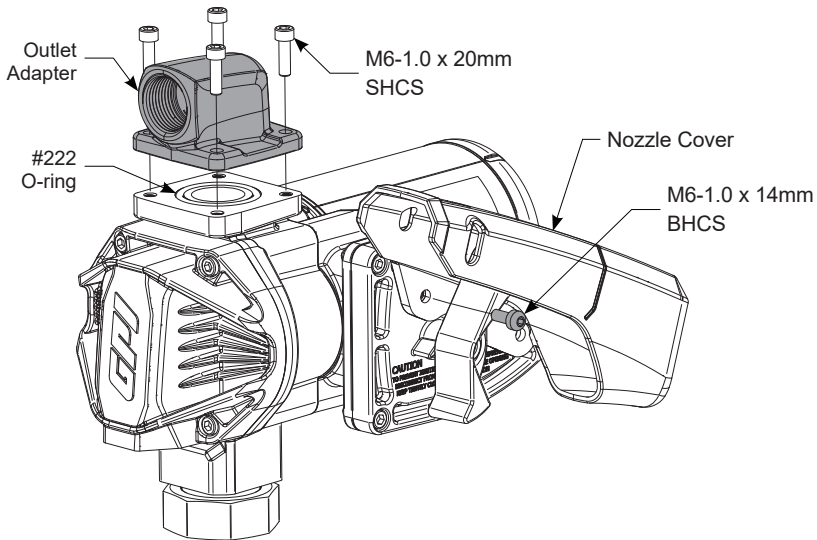

Figure 5

Install Hose and Nozzle

1. Wrap one end of the dispensing hose with three to four turns of thread tape and thread into outlet port. Tighten securely using an adjustable wrench.
2. Wrap opposite end of hose with three or four turns of thread tape and thread into nozzle. Tighten securely using an adjustable wrench.
3. Place the nozzle into the nozzle holder on the end of the pump motor housing. Note that the nozzle cannot be placed in the holder unless the pump switch is OFF (see Figure 9).



INSTALLATION INSTRUCTIONS (CONTINUED)

Installation of G20-012PX Model

For DIV 1 (UL)

⚠ DANGER *If the pump is to be installed in a Hazardous (Classified) location, it must be installed by a licensed electrician and conform to National Fire Protection Association (NFPA) codes 30 and 70. You as the owner, are responsible for seeing that the installation and operation of your pump complies with NFPA codes as well as any applicable state and local codes. Rigid conduit must be used to install wiring. Note that the lead wires are factory-sealed isolating the motor from the junction box.*

Failure to follow these wiring instructions may result in death or serious injury from shock, fire or explosion.

For Zone 1 or 2 (IECEx/ATEX)

Use a suitable Exd cable gland during Zone 1 or 2 installations. Conductors used for line voltage must have insulated rated at 105 °C or above.

Installation of G20-012AD and G20-012MD Models

NOTE: This pump is pre-wired for installation in CLASS I, DIVISION 2 locations such as portable fuel tanks, trailers, etc. Connection method to a battery will depend upon the application.

Installation Replacement Power Cord (DIV 2 ONLY)

For installation in unclassified areas, the supplied power cord, fuse and strain relief grip may be used.

NOTE: These components have not been evaluated as part of the UL Listed Equipment and are not intended for use in a Hazardous (Classified) Location.

To install the power cord, remove the (4) M6-1.0 x 20mm SHCS and electrical coverplate (see Figure 7).

If necessary, trim the power cord to the desired length. Strip 3 to 4 inches (7.5 to 10 cm) of outer insulation from the power cord end. Then strip 1/2 inch (1.3 cm) of insulation from the power cord wires.

Slide the strain relief grip onto the power cord so that the threaded end of the strain relief grip faces the stripped power wires (see Figure 6).

Insert the power cord through the 1/2 inch NPT connection on the back of the pump (see Figure 7). Using wire nuts, connect the black wire to the black wire and the red wire to the red in the pump's electrical cavity. Position the wires inside the electrical cavity and tighten the strain relief grip securely. Make sure surfaces are clean. Reinstall the electrical coverplate and switch lever, and tighten securely.

INSTALLATION INSTRUCTIONS (CONTINUED)

(Only for G20-012AD and G20-012 MD models)

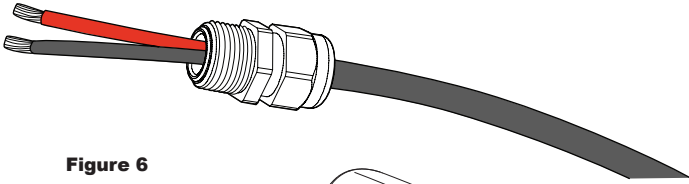

Figure 6

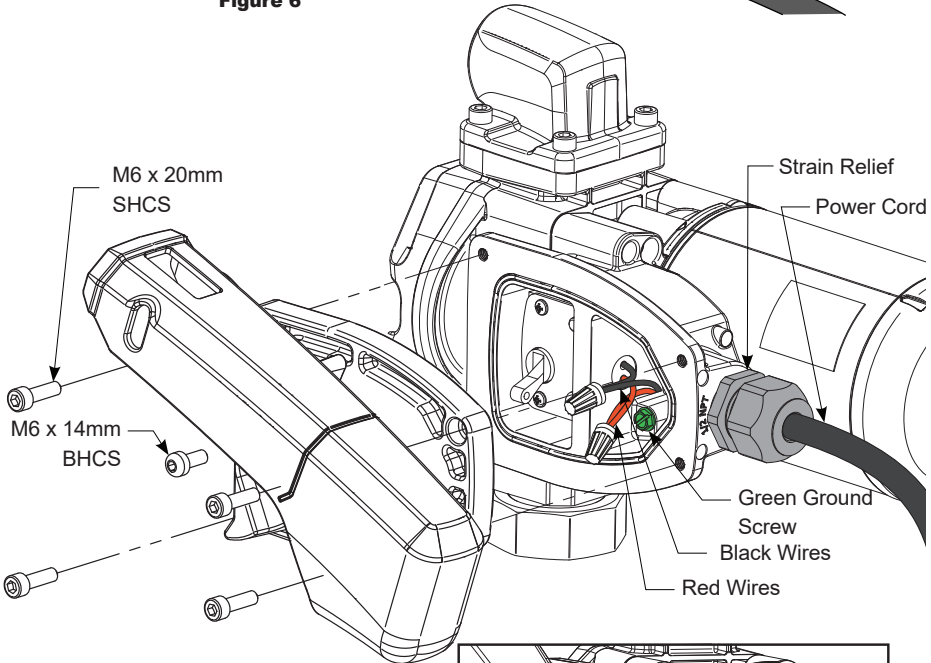

Figure 7

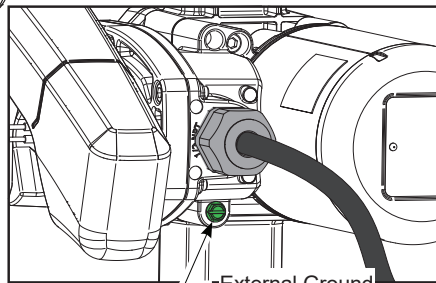

Figure 7a

Install Ground Wire

A grounding connection is provided. It is identified as a green colored binding head screw in the electrical cavity (see Figure 7): an external ground can be used instead. When using the external ground for the G20-012PX (Zone 1 or 2), the installer **must** use a ground wire with a minimum cross-sectional area of 4mm². To use external ground, remove green ground screw from electrical cavity and install in location shown (see Figure 7a).

INSTALLATION INSTRUCTIONS (CONTINUED)

Connect to a Power Source

NOTE: Please consult the Owner's Manual for your vehicle before proceeding.

IMPORTANT: The pump is designed for use with a 12 V (dc) power source. Do not attempt connection of any pump to a 24 V (dc), 115 V (ac) or 230 V (ac) power source.

⚠ WARNING *Do not attempt to power the pump from vehicle wiring smaller than 12 gauge, such as the cigarette lighter wire, as these thin wires could overheat and cause a fire.*

IMPORTANT: Verify switch is in OFF position (see Figure 9), then route the electrical wires to the source of the vehicle power system. Be sure to support the wires as necessary and protect them from sharp edges, heat or anything that could damage the wires.

1. If the power cord provided is too long, cut to desired length. Using a utility knife, carefully strip 3 to 4 inches of outer insulation from end of power cord. **DO NOT CUT INSULATION OF INNER WIRES.** Next, using wire strippers, remove 1/4 in. of insulation from the black and red power cord wires.
2. First disconnect vehicle wiring from the negative ground terminal of the battery, and then connect as follows: Using wire strippers, carefully strip 1/4 in. of insulation from both ends of the fuse assembly wire.
3. Insert one end of the fuse assembly wire into a wire connector (included) and crimp. Insert the red power cord wire into the other end of the wire connector and crimp. Make sure the fuse assembly is positioned outside of hazardous areas and as close to the battery as possible (see Figure 8).
4. Using wire crimpers, attach a terminal post ring (not included) to the other end of the fuse assembly and a terminal post ring to the end of the black power cord wire.
5. Connect the red wire/fuse assembly to the positive side of the battery (see Figure 8).
6. Connect the black power cord wire to the negative side of the battery.

NOTE: Connecting directly to the battery terminal or the end of the battery cable is recommended.

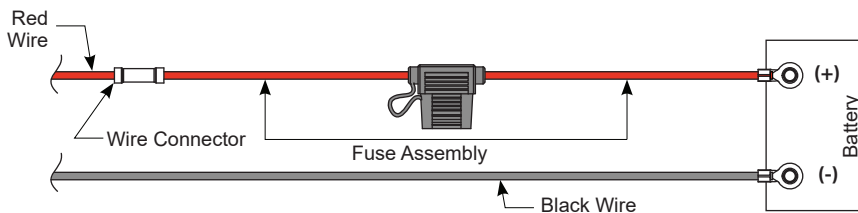

Figure 8

OPERATION

IMPORTANT: Always follow safety precautions when operating this equipment. Review the Safety Instructions.

⚠ DANGER *To prevent physical injury or property damage, observe precautions against fire or explosion when dispensing fuel. Do not operate the system in the presence of any source of ignition including running or hot engines, lighted tobacco products, gas or electric heaters, or any type of electronic device. A spark can ignite fuel vapors.*

⚠ CAUTION *Before each use, repair leaks around seals or connections. Make sure hoses are in good condition and connections are tight.*

NOTE: Make sure the work area is dry.

⚠ WARNING *Make sure the pump is properly grounded. Repair any corroded or damaged wiring before use.*

NOTE: Ensure the tank contains enough fuel.

IMPORTANT: Make sure the fuel is not contaminated with debris. Tighten loose tank lids regularly.

Dispensing Fuel

1. Remove the nozzle from holder and insert into receiving tank. Turn the pump on by pushing the switch lever up. Squeeze the handle to start fuel flow. When done, release the nozzle handle, turn the pump off, and return the nozzle to its holder.

IMPORTANT: This pump is designed to be self-priming. If fuel is not delivered within 15 to 20 seconds, turn the pump off and refer to priming information in the Troubleshooting Section.

⚠ CAUTION *An automatic bypass valve prevents pressure build up when the pump is on with the nozzle closed. To avoid pump damage, do not run the pump more than 10 minutes with the nozzle closed. Leaving the pump on with the nozzle closed for more than 10 minutes can damage the pump components and will void the warranty.*

⚠ CAUTION *Never leave the pump running without fluid. Dry running can damage the pump components, and will void the warranty.*

IMPORTANT: This is an intermittent duty pump, after running the pump for a maximum of 30 minutes, allow it to cool for 30 minutes.

OPERATION (CONTINUED)

Motor Protector

NOTE: This pump is equipped with a motor protective device that also serves as the ON/OFF switch. The motor protective device is not intended to provide branch protection.

1. If motor is overloaded, the protective device trips and opens the circuit. This feature protects the motor from damage and must be reset manually.
2. To reset, turn switch lever OFF and then back ON (see Figures 9 and 10).
3. If the protective device trips again quickly, disconnect from power source before attempting to troubleshoot the problem. Follow the instructions provided in the Troubleshooting section of this manual.
4. Make sure the switch lever is OFF before restoring power.
5. Turn switch lever ON and restart.

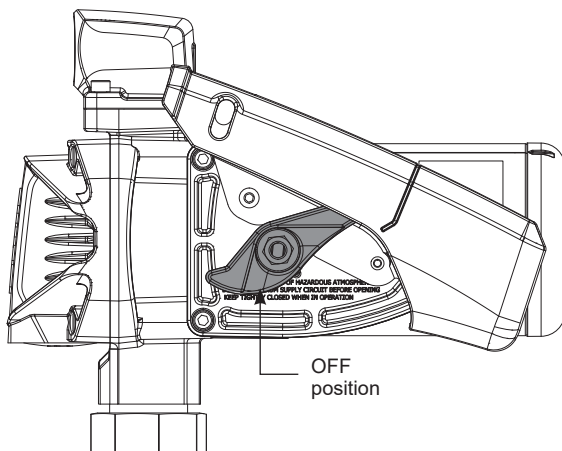

Figure 9

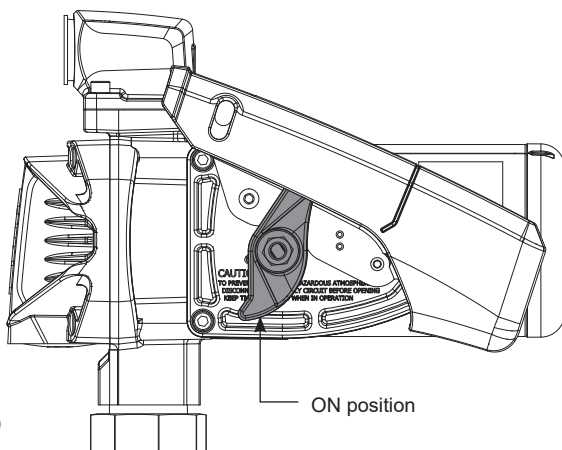

Figure 10

TROUBLESHOOTING

| Symptom | Possible Cause(s) | Corrective Action |
|------------------------------|--|---|
| Motor does not run | 1. Fuse blown | 1. Inspect fuse in fuse holder on power cord. If blown, replace |
| | 2. Switch defective | 2. Remove switch coverplate and inspect switch. Replace, if necessary |
| | 3. Switch or electrical connections are faulty | 3. Inspect for damaged fuse, defective wiring or switch or improper electrical connections. Replace as needed and reinstall |
| | 4. Circuit breaker tripped | 4. Turn power off at source. Inspect the pump thoroughly; clean or repair. Reset circuit breaker by turning the power switch off then back on |
| | 5. Motor damaged | 5. Replace pump |
| Motor runs but does not pump | 1. Motor running backwards due to incorrect polarity | 1. Connect red wire to positive (+) ungrounded side of battery. Motorshaft should turn clockwise |
| | 2. Poor connections or low voltage | 2. Make sure electrical connections are secure. Check battery voltage |
| | 3. Fuel level low | 3. Fill tank |
| | 4. Strainer clogged or defective | 4. Remove pump coverplate. Remove and clean strainer. Install again |
| | 5. System air leak | 5. Tighten all pump fittings and connections. Inspect suction pipe for leaks or damage |
| | 6. Suction pipe clogged, damaged or missing | 6. Remove pump from tank. Inspect suction pipe. Clean or replace, as necessary |
| | 7. Gear coverplate or O-ring damaged | 7. Remove and inspect the coverplate and O-ring. Replace, as necessary. (see Maintenance/Repair section) |
| | 8. Bypass poppet O-ring worn or missing | 8. Inspect O-ring (see Maintenance/Repair section). Replace, if necessary |
| | 9. Bypass poppet binding or damaged | 9. Remove the bypass poppet, spring, and O-ring. Clean cavity. Inspect and replace components, if needed |

**TROUBLESHOOTING (CONTINUED)**

| Symptom | Possible Cause(s) | Corrective Action |
|--|---|--|
| Low flow rate | 1. Strainer partially clogged | 1. Remove the strainer coverplate. Remove and clean the strainer. Install again |
| | 2. Poor connections or low voltage | 2. Make sure electrical connections are secure. Also check battery voltage |
| | 3. Fuel tank empty | 3. Fill tank |
| | 4. Suction pipe clogged or damaged | 4. Remove pump from tank. Inspect suction pipe. Clean or replace, as necessary |
| | 5. System air leak | 5. Tighten all pump fittings and connections. Inspect suction pipe for leaks or damage. Replace, as necessary |
| | 6. Using off-the-shelf automatic nozzle | 6. Factory-supplied automatic nozzle is recommended |
| Motor stalls when operating in bypass mode | 1. Motor protector activated | 1. Turn off switch. Allow motor to cool, then turn on switch |
| | 2. Wiring defective | 2. Use Wiring instructions in the Installation Section to ensure proper connections |
| | 3. Bypass poppet binding or damaged | 3. Using instructions in the Repair Section, remove the bypass poppet, spring and O-ring. Clean cavity. Inspect components and replace, as necessary |
| | 4. Motor damaged | 4. Replace pump |

TROUBLESHOOTING (CONTINUED)

| Symptom | Possible Cause(s) | Corrective Action |
|-------------------------------|--|---|
| Switch fails to operate motor | 1. Switch or electrical connections faulty | 1. Inspect for blown fuse, defective wiring or switch, or improper electrical connections. Refer to Switch Replacement instructions in the Repair Section |
| | 2. Motor protector activated | 2. Turn off switch. Allow motor to cool, then turn on switch |
| | 3. Motor damaged | 3. Replace pump |
| Overheating of motor | 1. Duty cycle too long | 1. Pump operation should not exceed the standard duty cycle of 30 minutes ON, and 30 minutes OFF. Allow the pump to cool for 30 minutes |
| | 2. Running too long in bypass mode | 2. Limit bypass operation to 10 minutes |
| | 3. Strainer clogged | 3. Remove strainer coverplate. Remove and clean strainer. Install again |
| | 4. Suction pipe clogged or damaged | 4. Remove pump from tank. Inspect suction pipe. Clean or replace, as necessary |

MAINTENANCE

NOTE: This pump is designed for minimum maintenance. The motor bearings are self-lubricating. Inspect the pump and components regularly for fuel leaks and make sure the hose and power cord are in good condition. Keep the pump exterior clean to help identify leaks.

IMPORTANT: Do not use this pump for water, chemicals or herbicides. Dispensing any fluid other than those listed in this manual (see **BEFORE YOU BEGIN: Fueling Requirements** at front of manual) may damage the pump. Use of the pump with unauthorized fluids will void the warranty.

Clean or Replace Strainer

1. Turn the pump off and disconnect from power. Using 5mm hex wrench, remove the coverplate, O-ring, and inlet strainer and inspect for damage or clogs (see Figure 11). Clean the strainer with a soft-bristled brush and solvent. If the strainer is very dirty, compressed air may be used. If damaged, replace the strainer.
2. Clean the coverplate and O-ring. Coat the O-ring lightly with grease. Reinstall the strainer, O-ring and coverplate. Ensure the O-ring is properly seated and tighten securely.

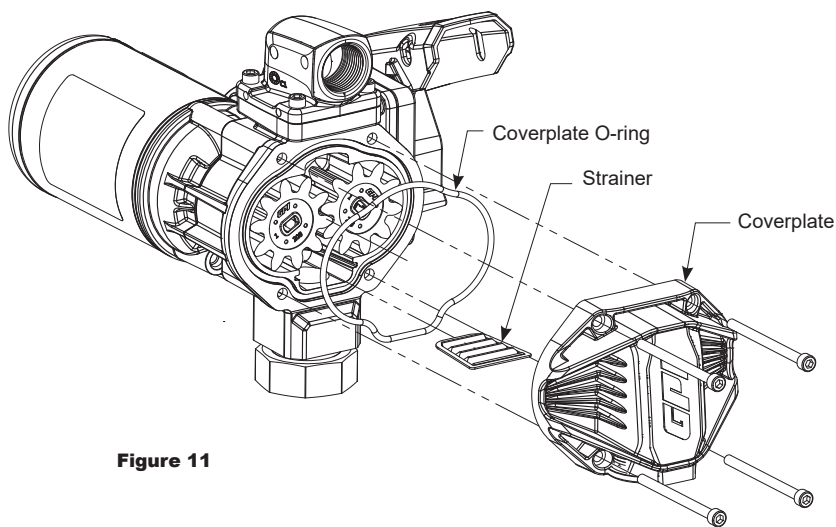

Figure 11

REPAIR

IMPORTANT: Carefully inspect all parts for wear or damage. Replace components, as necessary. The Illustrated Parts List gives information on replacement parts and kits. Review the Safety Instructions before proceeding.

⚠ DANGER *Observe precautions against electrical shock when servicing the pump. Always disconnect power before repairing or servicing. Never apply electrical power to the system when any of the coverplates are removed.*

⚠ WARNING *Avoid prolonged skin contact with petroleum fuels. Use protective goggles, gloves and aprons in case of splashing or spills. Change saturated clothing and wash skin promptly with soap and water.*

Service O-rings

NOTE: A Wet Seal Kit contains all seals for your pump and should be on hand when performing repairs. Old seals may then be replaced with new seals.

1. In general, when inspecting O-rings, look for breaks, wear, and signs of deterioration, such as swelling.
2. Replace, as necessary.
3. Before seating, coat O-rings with light grease.

REPAIR (CONTINUED)

Replace Gears

1. Turn the pump OFF and disconnect from power.
2. Using 5mm hex wrench, remove the gear coverplate and O-ring (see Figure 12).
4. Remove the gears.
5. Inspect gears for wear and damage. Replace, as necessary.
6. Wipe the gear cavity with a clean cloth.
8. Replace the gears.
9. Make sure the gear coverplate O-ring is securely in place. Tighten the coverplate to the housing.
10. Clean Bypass poppet (see Figure 13).

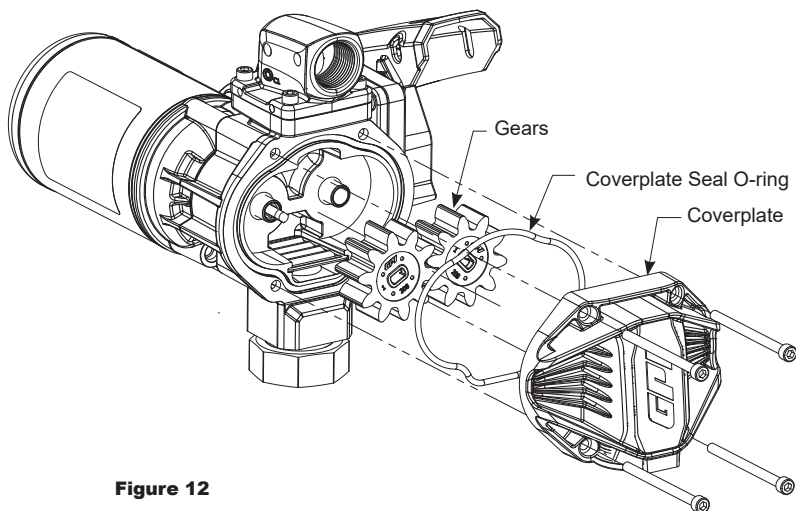

Figure 12

REPAIR (CONTINUED)

Clean and Replace Bypass Poppet

1. Turn the pump OFF and disconnect from power.
2. Using a 5mm Hex wrench, remove the coverplate from the pump.
3. With a 10mm Hex wrench remove the pipe plug from the coverplate, and remove the bypass poppet spring, O-ring, bypass poppet and orifice seal (see Figure 13).
4. Inspect the O-ring and replace as necessary

NOTE: Replace O-ring if damaged, swollen or loose-fitting (see Wet Seal Kit).

5. With a clean cloth, wipe the poppet components and replace.
6. Before seating, coat O-ring with light grease.
7. Install coverplate.

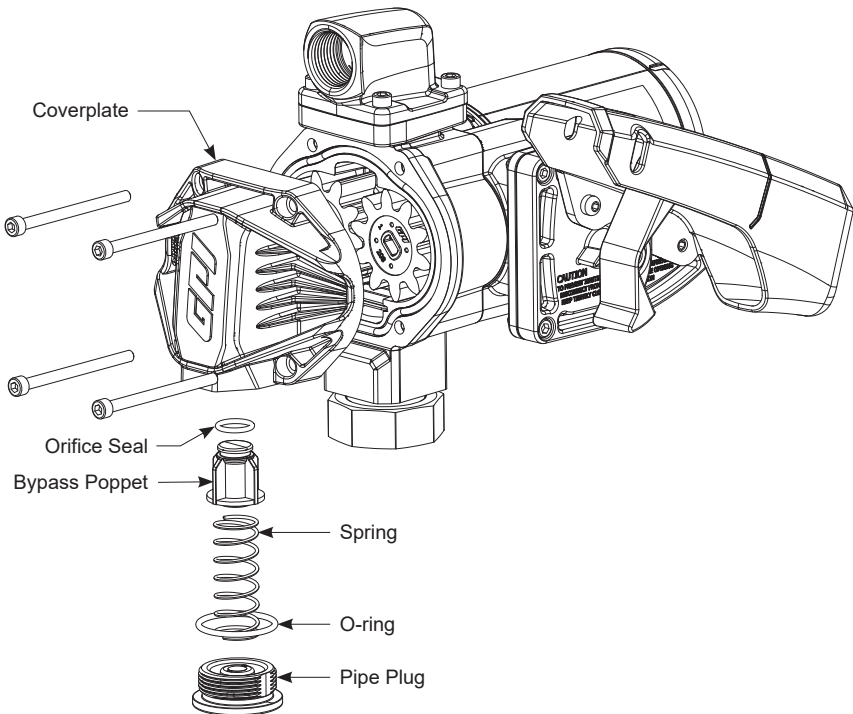

Figure 13

REPAIR (CONTINUED)

Replace Motor Shaft Seal

1. Turn the pump OFF and disconnect from power.
2. Using a 5mm Hex wrench, remove the (4) M6 x 80mm SHCS on gear coverplate and (1) M6 x 35mm SHCS located on back of pump housing. Separate pump housing and fittings from drive shaft (see Figure 14).
3. Remove motor shaft seal from pump housing (see Figure 14).
4. Press a new motor shaft seal evenly in the pump housing until seated. Lubricate the seal with a lightweight motor oil.
5. Reinstall pump housing with gear coverplate, gears and fittings.

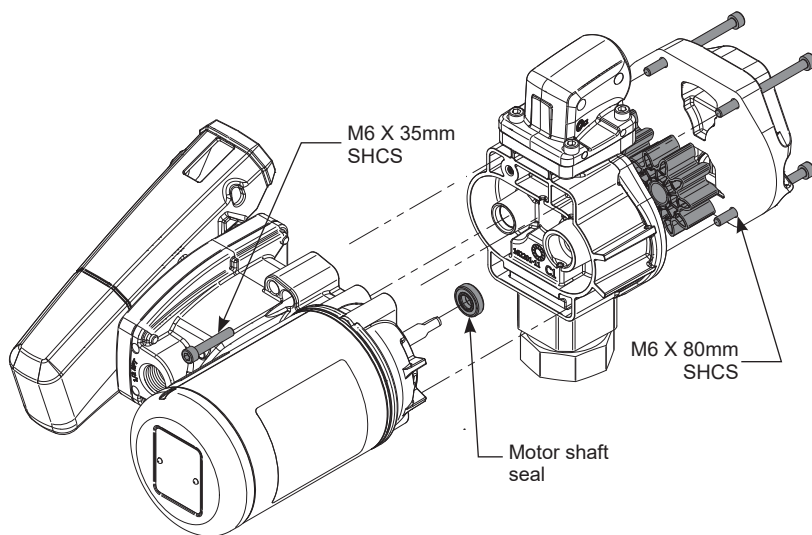

Figure 14

REPAIR (CONTINUED)

Replace Power Switch

1. Turn the pump OFF and disconnect from power.
2. Using a 4mm Hex wrench remove the M6 BHCS and nozzle cover.
4. Remove the (4) M6 SHCS and electrical coverplate from the motor housing.
5. Remove the (1) #10 truss head screw and switch bracket with switch assembly (see Figure 15).
6. Unscrew both #6 machine screws and remove the switch assembly from the switch bracket.
7. Unscrew both blade terminals and remove red pump wires from the back of the switch (see Figures 15 and 16). Take note of which wire is attached to each blade terminal for reinstallation.
8. Install a new switch by reversing the above procedure. Insert the switch assembly into the pump cavity. Reinstall all components.

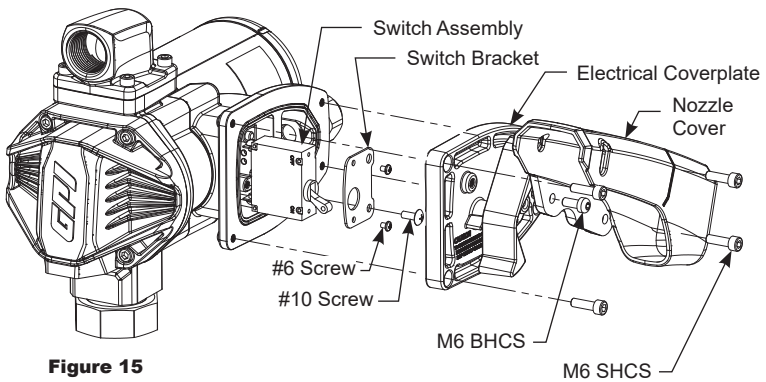

Figure 15

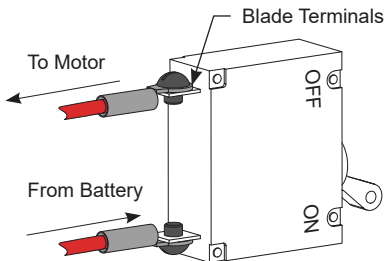

Figure 16

Remove Pump From Tank

1. Turn the pump OFF and disconnect from power.
2. Unthread and lift the pump and suction pipe straight up from the tank adapter.
3. Elevate the nozzle and hose to allow excess fuel to drain into the tank.
4. Wipe the entire system with a clean cloth.



REPAIR PARTS ILLUSTRATION FOR G20-012PX, G20-012MD AND G20-012AD

CAUTION Do not return the pump or parts without prior approval from the GPI Customer Service Department. Due to strict government regulations, GPI cannot accept parts unless they have been drained and cleaned.

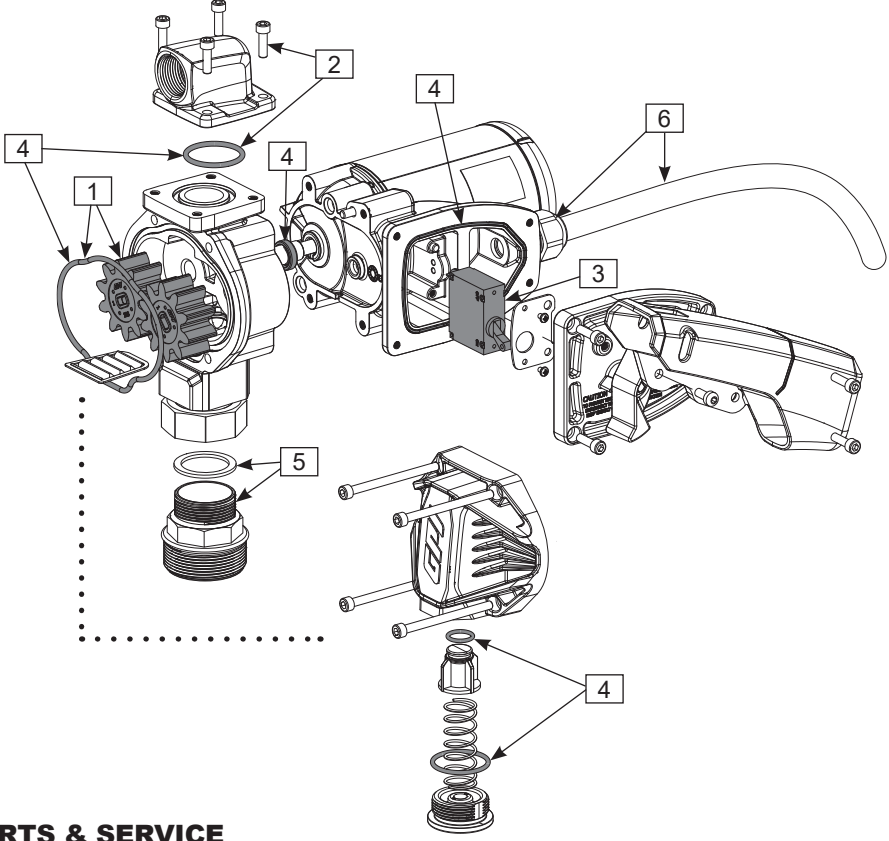

PARTS & SERVICE

For warranty consideration, parts, or other service information, please contact your local distributor. If you need further assistance, contact the GPI Customer Service Department in Wichita, Kansas, during normal business hours.

To obtain prompt, efficient service, always be prepared with the following information:

- The model number of your pump.
- The serial number or manufacturing date code of your pump.
- Part descriptions and numbers.

For warranty work, always be prepared with your original sales slip or other evidence of purchase date.

REPAIR PARTS LIST FOR G20-012PX, G20-012MD AND G20-012AD

| Ref. No. | Description | Part Number | Qty. |
|----------|-----------------------------|-------------------|------|
| 1 | Gear Kit | 162501-01 | |
| | Gear Coverplate O-ring #226 | ▲ | 1 |
| | Gears | ▲ | 2 |
| 2 | Outlet Hardware Kit | 162516-503 | |
| | 5mm Hex Key (not shown) | ▲ | 1 |
| | M6-1.0 x 20mm SHCS | ▲ | 4 |
| | Outlet Port O-ring #222 | ▲ | 1 |
| 3 | Switch Assembly | 902006-555 | 1 |
| 4 | Seal Kit | 162502-01 | |
| | Bypass Valve Orifice Seal | ▲ | 1 |
| | Bypass Poppet O-ring #920 | ▲ | 1 |
| | Gear Coverplate O-ring #226 | ▲ | 1 |
| | Outlet Port O-ring #222 | ▲ | 1 |
| | Motor Shaft Seal | ▲ | 1 |
| | Electrical Coverplate Seal | ▲ | 1 |
| 5 | Bung Adapter Kit | 110909-1 | |
| | Bung Adapter | ▲ | 1 |
| | Gasket | ▲ | 1 |
| 6 | Power Cord Kit | 110242-01 | |
| | Power cord 12-2 | ▲ | 1 |
| | Strain relief | ▲ | 1 |

(▲) Available as part of kit only.

IMPORTANT: Please contact GPI before returning any parts. It may be possible to diagnose the trouble and identify needed parts in a telephone call. GPI can also inform you of any special requirements you will need to follow for shipping fuel dispensing equipment.

IMPORTANT: In order to preserve the UL Listing for the motor, do not attempt to service the motor. For products serviced outside the factory, the UL nameplate must be defaced to indicate that the equipment may no longer meet the requirements for UL Listing. This does not apply to products serviced outside the factory under the UL program for Rebuilt Motors for Use in Hazardous Locations.