

- Solid forged body
- Angled body for hard to reach areas
- Heat treated high carbon steel, plated and black oxide

**INSTRUCTIONS:** This tool features a two position cutter. Best operation is obtained by rotating the chisel edge one-half a turn to produce proper splitting action when the tool is used as illustrated.

- Set cutter as shown and tighten bolt to break nut surface

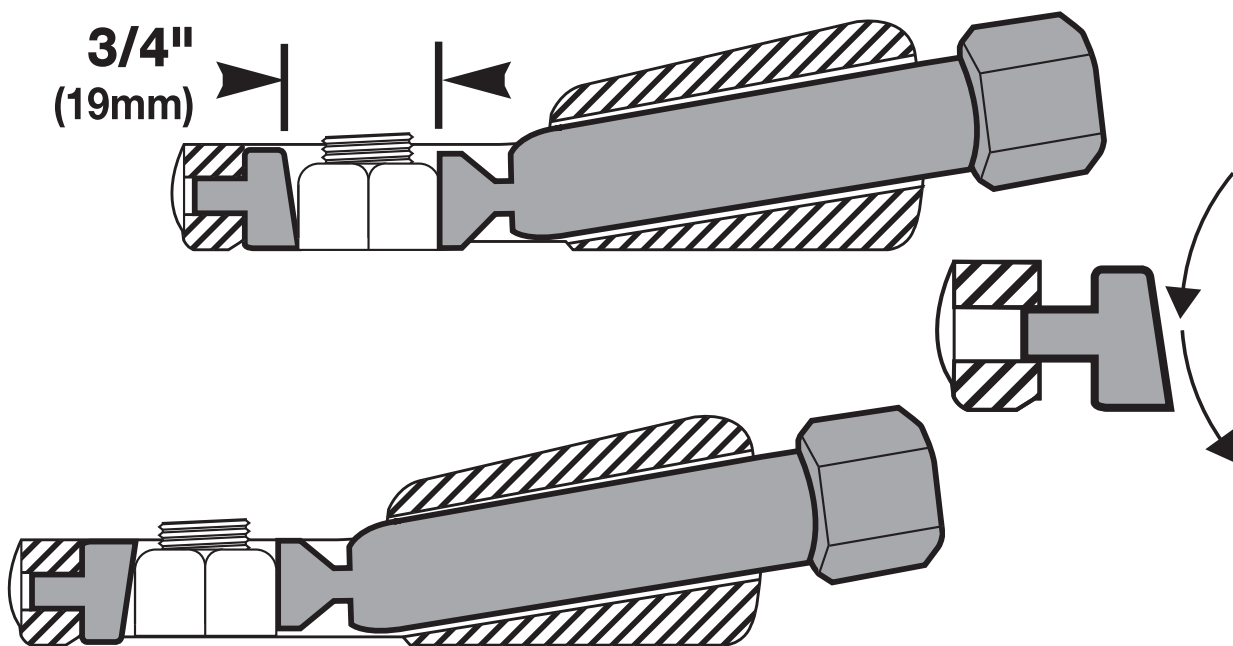

**WARNING: Do not use with power tool.**



**Avoid injury:** Always wear OSHA/ANSI approved eye protection (goggles, face shield) when using tools.