

FLUKE®

80T-150UA

Universal Temperature Probe

Instruction Sheet

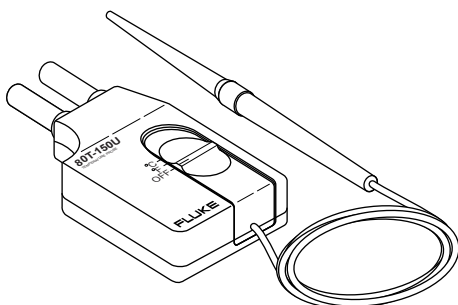

Introduction

The Model 80T-150UA Universal Temperature Probe is a self-contained temperature-to-voltage converter. The probe is designed to provide a direct temperature reading when it is connected to any high impedance DMM that is capable of 1 mV resolution and at least a 300-count full scale readout capability. Output is 1 mV per degree (Celsius or Fahrenheit). Two switch-selected temperature output scalings are provided: -50 to +150 °C or -58 to +302 °F. The probe will stand off 60 V dc or 30 V ac rms (42.4 V peak).

The unit is housed in two separate but attached assemblies: a temperature probe and a temperature-to-voltage converter. The probe contains the temperature-sensing element and is electrically connected to the temperature-to-voltage converter through a 46-inch cable. A three-position switch on the converter acts as a power switch and is used for selecting Celsius or Fahrenheit scaling for the output. Two banana plugs with standard 0.75-inch spacing are provided for connecting the 80T-150UA to the DMM.

Operating power for the 80T-150UA is derived from a standard 9 V battery. Typically, an alkaline battery provides more than 600 hours of continuous operation before replacement is necessary. An OFF switch is provided on the temperature-to-voltage converter to allow battery conservation when the unit is not in use. In addition, the OFF position of the power switch allows the battery condition to be determined via the external DMM.

Temperature is measured by exposing the probe tip directly to the material to be measured (non-corrosive liquid, gas, or solid). A direct temperature reading is displayed on the DMM.

Symbols

- ⚠ Warning:** Risk of electric shock. Refer to the manual for information.
- ⚠ Attention:** Refer to the manual for information about this feature.

Specifications

The 80T-150UA will achieve rated accuracy when it is used with any 0.25 % DMM that has an input impedance of $\geq 1 \text{ M}\Omega$.

Electrical

Measurement Range: (See Probe Limitations)

-50 to +150 °C
-58 to +302 °F

Accuracy: (Applies for one year after purchase or calibration)

AMBIENT °C +15 to +35 °C	ACCURACY ± 1 °C from 0 to +100 °C, decreasing linearly to ± 3 °C at -50 and +150 °C
0 to +15 °C and +35 to +50 °C	± 2 °C from 0 to +100 °C, decreasing linearly to ± 4 °C at -50 and +150 °C
AMBIENT °F +59 to +95 °F	ACCURACY ± 1.8 °F from +32 to +212 °F, decreasing linearly to ± 5.4 °F at -58 and +302 °F
+32 to +59 °F and +95 to +122 °F	± 3.6 °F from +32 to +212 °F, decreasing linearly to ± 7.2 °F at -58 and +302 °F

Sensitivity (80T-150UA output): 1 mV dc / °C or °F

Voltage Standoff: 60 V dc or 30 V ac rms (42.4 V peak)

Settling Time: 9.5 seconds to settle within 2 ° for a 50 ° change

RF Field: The 80T-150UA product is unspecified in environments with EMC fields greater than 100 mV/meter. ESD performance is specified as Criteria B per EN61326.

Environmental

Ambient Operating Range for Temperature Module: 0 to +50 °C (+32 to +122 °F)

Maximum Temperature Probe Body and Cable: +70 °C (+160 °F) See Probe Limitations

Minimum Temperature Probe Body and Cable:

Minimum Operating Temperature for Cable: -12 °C (+10 °F)
Minimum Operating Temperature for Probe Body: -40 °C (-40 °F)
See Probe Limitations

Storage Temperature for Unit: -40 to +70 °C (-40 to +160 °F)

Humidity: 0 % to 90 % (0 °C to +35 °C)

0 % to 70 % (+35 °C to +50 °C) (noncondensing)

Altitude: Operating: ≤ 3048 m ($\leq 10,000$ ft)
Storage: ≤ 15240 m ($\leq 50,000$ ft)

Application Force: 15 pounds maximum (probe tip to measured surface)

General

Weight: 150 g (5.3 oz)

Overall Length: 53.8 inch (1.36 m)

Battery: Standard 9 V battery (NEDA #1604,6F22,006P)

Battery Life: 600+ hours, typical (Alkaline Battery), 6.5 V minimum

Output Termination: Standard 0.75-inch spaced double banana plug

Probe Material: Glass-filled valox

Probe Size: 0.6 inch maximum diameter

Tip Material: Nickel Plated Copper

Tip Size: 0.31 cm (0.12 inch diameter)

Operating Notes

The following paragraphs are intended to familiarize the operator with the 80T-150UA. The operator should read these paragraphs before attempting to operate the probe.

Probe Limitations

The 80T-150UA probe is constructed of a highly durable plastic and is suitable for measuring the temperature of liquids, gases, and solid surfaces up to 150 °C. When measuring temperature, observe the following precautions to prevent damage to the probe:

1. Do not expose the probe end (probe tip plus about 2 inches of the probe body) to temperatures exceeding +150 °C (+302 °F). The remainder of the probe body should not be exposed to temperatures above +70 °C (+160 °F).
2. Do not expose the probe end (probe tip plus about 2 inches of the probe body) to temperatures below -50 °C (-58 °F). The remainder of the probe body should not be exposed to temperatures below -40 °C (-40 °F).
3. For liquid measurements, recommended applications range from water, lubricants, and fuels to most solvents. Liquids as shallow as 1.27 cm (0.5 inch) can be measured since the temperature sensor is 1 inch from the probe tip.

Warning

To avoid electrical shock, do not use this instrument when voltages exceeding 60 V dc or 30 V ac rms (42.4 V peak) are present. The probe tip is electrically connected to the output terminals.

Caution

Long-term exposure of the probe to corrosive environments will result in pitting and deterioration of the aluminum probe tip. If equipment is used in a manner not specified by the manufacturer, the protection provided by the equipment may be impaired.

Error Sources

When the probe tip is applied to a solid surface, it draws or sinks heat from the surface. Therefore, if the measured surface has a low mass (e.g., a transistor case), the indicated temperature may be lower than the actual temperature.

Similarly, a steady-state error or gradient exists between the measured surface and the sensing device in the probe tip. This is due to the flow of heat from the measurement surface to the probe body. The effect of the steady-state error increases as the differential between ambient and surface temperature increases.

To determine the actual surface temperature of a device, both the heat-sinking and steady-state errors must be considered. The correction curve given in Figure 1 approximates the effect of both error sources on TO-3, TO-5, and TO-18 transistor cases.

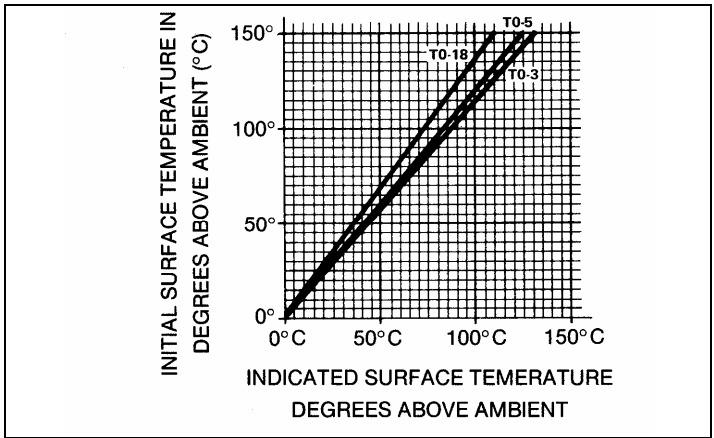

F1.eps

Figure 1. Initial Case Temperature Above Ambient vs Meter Reading Above Ambient

Operation

Use the following procedure to operate the 80T-150UA probe:

1. Connect the banana plugs on the 80T-150UA to the input terminals of a high impedance DMM. Observe polarity.
2. Select a dc voltage range that will provide at least 1 mV/degree and a full scale readout that will encompass the expected temperature. The 2 V range of a 3 1/2-digit DMM is adequate. Ignore readings of less than 1° when a more sensitive DMM is used.
3. Set the 80T-150UA power switch to °C or °F, and energize the DMM.
4. Firmly touch the probe tip to the surface to be measured, or expose it to a liquid or gas. The DMM will display the temperature in degrees. Vary the probe angle and pressure when measuring solid surface temperatures. The highest stabilized reading will be the most accurate. (See the following measuring technique.)

⚠ Caution

The force exerted on the probe tip should not exceed 15 pounds.

Measuring Technique

Here are some suggestions for improving the accuracy of your temperature measurements:

1. When measuring higher than ambient temperatures, adjust the connection between the probe and the surface until you get the highest temperature reading.
2. When measuring lower than ambient temperatures, adjust the connection between the probe and the surface until you get the lowest temperature reading.
3. When measuring near ambient temperatures, make the reading when the multimeter readout is most stable.

General Maintenance

Access Information

The battery and the calibration pots are located on the interior of the temperature-to-voltage converter assembly. Access to these locations is accomplished by removing the screw from the bottom side of the assembly and removing the top of the plastic box.

Battery Condition Test

1. Set the power switch to the OFF position.
2. Connect the 80T-150UA to the DMM.
3. Set the DMM to the 200 or 400 mV dc range.
4. Read the battery test voltage on the DMM or test instrument. For DMMs with 10 MΩ input impedance, a minimum reading of 100 mV is acceptable. For test instruments with 1 MΩ input impedances, such as ScopeMeter®, a minimum reading of 75 mV is acceptable. With these minimum readings, approximately 100 hours of battery life remain.

Battery Replacement

Warning

To avoid electrical shock, remove the probe from the measurement surface before opening the case. Totally reassemble the instrument before attempting to use it.

1. Set the power switch to the OFF position.
2. Disconnect the 80T-150UA from the DMM.
3. Turn the 80T-150UA so the power switch is facing down. Remove the single screw located between the banana plugs.
4. Grasp one case half in each hand. Pull the two halves apart, beginning at the end with the banana plugs.
5. Remove and replace the battery.
6. Reassemble the 80T-150UA as follows. Mate the two case halves at the end where the cable enters the case, then "hinge" the two halves together. Replace the case screw, being careful not to pinch the probe cable or battery wires.

Performance Test

Complete the calibration procedure without opening the temperature-to-voltage converter assembly and without making any calibration adjustments. Observe the readings given in [brackets]. Other readings are for calibration only.

Calibration

The calibration cycle of one year is recommended to maintain the unit within the specifications given earlier. The equipment required for calibration is listed in the table following the calibration procedure.

Note

Values given in brackets apply to the Performance Test.

Perform the following steps to calibrate the 80T-150UA:

1. Access the interior of the temperature-to-voltage converter by removing the bottom case screw and separating the case halves.
2. Connect the 80T-150UA to a Fluke 289, and select 500 mV dc range.
3. Select the °C position of the switch. Immerse the probe tip 5.1 cm (2 inches) into a mercury thermometer monitored 0 °C bath, and allow a full 5 minutes for the reading to stabilize.
4. Adjust VR3 and VR1 (see Figure 2) to obtain the following reading: 0.00 ±0.05 mV dc [0 ±0.2 mV dc]
5. Select the °F position of the switch, and adjust VR2 to obtain the following reading: 32.0 ±0.1 mV dc [32.0 ±0.4 mV dc]
6. Select the °C position, and move the probe tip to a 70 °C bath and again allow the reading to stabilize.
7. Adjust VR4 to obtain a Fluke 289 reading that agrees with the bath temperature (BT) as monitored by a mercury thermometer. °C BT ±0.05 mV dc [BT ±0.2 mV dc]
8. Select the °F position, and verify that the output is within ±4 mV dc of the bath thermometer reading. If necessary, change the Fluke 289 range to obtain an on-scale reading.
9. Return the probe tip to the 0 °C bath wait 10 minutes, then check the output. If readjustment is necessary, repeat steps 4 through 8 until the readings can be obtained without adjustment.
10. Set the 80T-150UA switch to the OFF position, and remove the 80T-150UA from the Fluke 289.
11. Reassemble the 80T-150UA.
12. The 80T-150UA is now calibrated.

Cleaning

Clean the test tool with a damp cloth and a mild soap. Do not use abrasives, solvents, or alcohol. These may damage the text on the test tool.

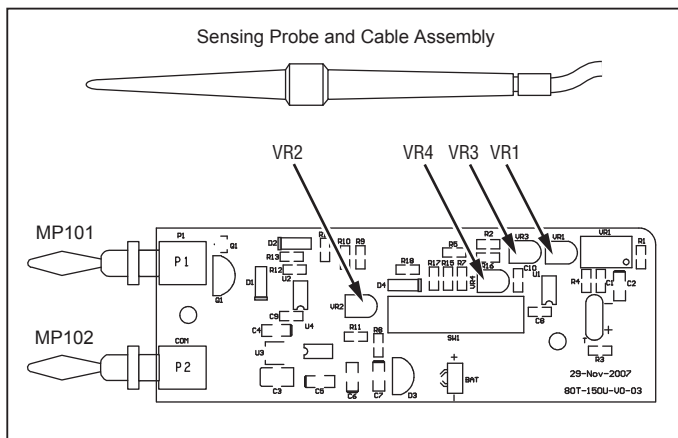

F4.eps

Figure 2. 80T-150UA Temperature Probe

Test Equipment Requirements

Instrument Type	Minimum Use Specifications	Recommended Model
Mercury Thermometer	0.1 °C Resolution	Princo Model SAMA-CP45
Dewar Flask and Cap	1-Pint Capacity (for Ice Bath)	Thermos Bottle
Metal or Glass Container	1-Pint Capacity	Suitable for Boiling Water
Handheld Digital Multimeter	500 mV Range with 10 μV Resolution	Fluke Model 289