

FLUKE®

PRODUCT CATALOG 2020-2021



About Fluke	4-5	Power quality and energy analysis	38
Digital multimeters	6	Featured products	39
Featured products	7	Selection guide	40-41
Selection guide	8-9	Battery analyzers	42
Clamp meters	10	Featured products	43
Featured products	11	Selection guide	43
Selection guide	12-13	Process calibration tools	44
Condition monitoring	14	Featured products	45-48
Featured products	15	Selection guide	49-51
Bench multimeters	16	Intrinsically safe products	52
Featured products	17	Portable oscilloscopes	53
Selection guide	17	Featured products	54
Layout and distance	18	Selection guide	55
Featured products	19	Industrial imaging	56
Selection guide	20-21	Featured products	57-60
Earth ground testers	22	Selection guide	61-65
Featured products	23	Vibration and alignment tools	66
Selection guide	23	Featured products	67
Multifunction installation testers	24	Insulated hand tools	68
Featured products	25	Featured products	69
Selection guide	26	Selection guide	70
Portable appliance testers	27	Accessories	71
Featured products	28	Featured accessories	72
Selection guide	29	Test leads/fuses	73
Electrical testers	30	Modular test leads	74
Featured products	31	Test lead kits	75
Selection guide	32	Temperature accessories	76
Indoor air quality	33	Cases and holsters	77
Featured products	34	Clamps	78
Selection guide	35	Recommended accessories	79
Insulation testers	36	Industrial Ethernet tools	80
Featured products	37	Featured products	81
Selection guide	37	Selection guide	81

ABOUT FLUKE

Dedicated to your safety, driven by your success

At Fluke, we're working every day so you can do your essential work with confidence. We are driven to keep you safe, help you succeed and equip you for maximum impact in your industry. Our modern, technology-enabled world works because people like you are at this very moment maintaining it, measuring it, testing it and improving upon it.

The future of Fluke

Our founder, John Fluke Sr. was a "get the job done right" kind of guy. His vision revolved around improving the way things work, and he saw test and measurement as the surest and most effective way of doing that.

Today, we're expanding our product line beyond the physical tools that defined our early history. But at Fluke the one thing that never changes is our commitment to the people who use our tools: you.

One world—one Fluke

Throughout the year and around the globe, Fluke leads events that bring communities together for greater impact. One example is the WorldSkills Competition. At this epicenter of vocational education and training, Fluke engages with students and professionals from around the world to share industry best practices and show how Fluke can help fill critical skills gaps in all industries.

Taking our commitment further

Fluke's support doesn't begin or end with a tool. Our website is loaded with hundreds of useful resources, such as blog posts, videos, how-to guides and more, to help you stay ahead of the curve.

Fluke on top

Rated #1*

Innovation



Quality



Value



Top product

2018 Product of the Year
Plant Engineering

Top choice

2019 Engineer's Choice Award
Control Engineering

Top in innovation

2018 Innovation Award Winners (2)
Pro Tools Review

Top in safety

2019 New Product Competition Award
Protective tools, hardware and equipment
MCEE

Top in breakthrough technology

2018 Breakthrough Product Award
Processing Magazine

*2019 IMI International Brand Equity Study

FLUKE

BY THE NUMBERS

1948 **71** 2019
YEARS

 **1250** TOOLS

1497 PATENTS 

 **4000+** EMPLOYEES

 **100+** COUNTRIES

 **562** BLOG ARTICLES

565 VIDEOS 

789 APPLICATION NOTES 

 **76** ON-DEMAND WEBINARS

 **5** ONLINE COURSES

DIGITAL MULTIMETERS

When uptime matters

Fluke digital multimeters (DMMs) are on more tool belts, finding more problems, than any other comparable test tools. Each industrial meter is tested to the extreme—drop, shock, humidity, you name it. Every Fluke digital multimeter gives you accurate measurements, consistent and reliable performance, attention to safety, and the strongest warranty available.

Fluke has a full family of digital multimeters. Whether you work in the residential or commercial world, deal with HVAC equipment or electricity, there's a Fluke digital multimeter for you.



FEATURED PRODUCTS

DIGITAL MULTIMETERS



Fluke 87V Industrial Multimeter

Fluke 87V identifies complex signal problems fast

The Fluke 87V Industrial Multimeter provides the resolution and accuracy to efficiently troubleshoot motor drives, plant automation, power distribution and electromechanical equipment. A low-pass filter lets you troubleshoot VFDs and captures intermittents as fast as 250 μ S.

Features include frequency to 200 kHz, plus % duty cycle, resistance, continuity and diode test. And it includes a built-in thermometer so you can take temperature readings without having to carry a separate instrument.

Correctly measure pulse-width modulated motor-drive signals

The Fluke 87V includes a unique function for accurately measuring noisy VFD signals. Special shielding blocks high-frequency, high-energy noise generated by large drive systems.

Electrical safety

All inputs for the 87V are compliant to overvoltage category CAT III 1000 V/CAT IV 600 V. They are designed to withstand spikes in excess of 8,000 V.



Fluke 11x Series True-rms Digital Multimeters

The Fluke 11x series has five True-rms digital multimeters, each for specific users. The compact instruments offer convenient one-handed operation and a backlit display with large, easy-to-read digits.

- **Fluke 117 Electrician's Multimeter** ideal to work in commercial and non-commercial premises, with non-contact voltage detection for faster and safer operation.
- **Fluke 116 Multimeter with temperature and microamps**, specifically designed for heating, ventilation and air conditioning (HVAC) professional.
- **Fluke 115 Field Service Testing Multimeter** is the solution for a wide variety of electrical and electronic testing applications.
- **Fluke 114 Electrical Multimeter** is the best troubleshooting tool for "go/no-go" testing in residential and commercial areas.
- **Fluke 113 Multimeter** is for basic electrical tests and repairing most electrical problems.



Fluke 179 True-rms Digital Multimeter

The Fluke 179 is the preferred solution for professional technicians around the world. It includes the troubleshooting features you use every day, plus a backlit digital display, analog bar graph and built-in temperature measurements.

Works when you need it, where you need it

The Fluke 179, with its true-rms capabilities, is independently tested for use in CAT III 1000 V/CAT IV 600 V environments and is backed by a lifetime warranty. The 179 comes with an ergonomic case with an integrated protective holster.

DIGITAL MULTIMETER SELECTION GUIDE



Models	Advanced meters		General purpose		
	289/287	87V	175/177	179	233
Basic features					
Counts	50000	20000	6000	6000	6000
True-rms readings	ac+dc	ac	ac	ac	ac
Basic dc accuracy	0.025 %	0.05 %	0.15 %, 0.09 %	0.09 %	0.25 %
Wide bandwidth	100 kHz	20 kHz			
Auto/manual ranging	••	••	•/•	•/•	•/•
Digits	4-1/2	4-1/2	3-1/2	3-1/2	3-1/2
Intrinsically safe ATEX safety rating					
Measurements					
Voltage ac/dc	1000 V	1000 V	1000 V	1000 V	1000 V
Current ac/dc	10 A	10 A	10 A	10 A	10 A
Resistance	500 MΩ	50 MΩ	50 MΩ	50 MΩ	40 MΩ
Frequency	1 MHz	200 kHz	100 kHz	100 kHz	50 kHz
Capacitance	100,000 μF	10,000 μF	10,000 μF	10,000 μF	10,000 μF
Temperature	(+) 1350 °C (2462 °F)	(+) 1090 °C (1994 °F)		(+) 400 °C (752 °F)	(+) 400 °C (752 °F)
Conductance/dB	50 nS/60 dB	50 nS/-			
Duty cycle/pulse width	•/•	•/-			
Continuity/diode test	•	•	•	•	•
Motor Drive (ASD) Measurements	• (289)	•			
VoltAlert™, non-contact voltage detection					
VCHECK™					
Lo ohms	• (289)				
LoZ: low input impedance	• (289)				
Microamps	•	•			
Display					
Fluke Connect® enabled	•*				
Backlight	Two level	Two level	•	•	•
Graphical trend display	•	•	•/-	•	
Diagnostics and data					
Min/max recording with time stamp	•/•	•/-	•/-	•/-	•/-
Display hold/auto (touch) hold	•/•	•/•	•/•	•/•	•/•
Relative reference	•	•			
Stand-alone logging	•				
Trend capture					
Readings memories	10,000				
USB interface	•				
Other features					
Automatic selection, ac/dc volts					
Infrared camera resolution					
Infrared camera range					
iFlex compatibility					
Insulation test voltages					
PI/DAR timed ratio test					
Completely sealed and watertight					
Warranty and electrical safety					
Warranty (years)	Lifetime	Lifetime	Lifetime	Lifetime	3
Input alert	•	•			
IP rating		IP30			
EN61010-1 CAT III	1000 V	1000 V	1000 V	1000 V	1000 V
EN61010-1 CAT IV	600 V	600 V	600 V	600 V	600 V



Models	Compact meters			Specialty meters			
	117/115	116	114/113	279 FC	1587 FC	28 II/28 II Ex	27 II
Basic features							
Counts	6000	6000	6000	6000	6000	20000	6000
True-rms readings	ac	ac	ac	ac	ac	ac	
Basic dc accuracy	0.5 %	0.5 %	0.5 %	0.09 %	0.09 %	0.05 %	0.1 %
Wide bandwidth						20 kHz	30 kHz
Auto/manual ranging	•/•	•/•	•/•	•/•	•/•	•/•	•/•
Digits	3-1/2	3-1/2	3-1/2	3-1/2	4-1/2	4-1/2 / 3-1/2	3-1/2
Intrinsically safe ATEX safety rating						28 II Ex	
Measurements							
Voltage ac/dc	600 V	600 V	600 V	1000 V	1000 V	1000 V	1000 V
Current ac/dc	10 A	600 µA		2500 A ac (with iFlex)	400 mA	10 A	10 A
Resistance	40 MΩ	40 MΩ	40 MΩ	50 MΩ	50 MΩ	50 MΩ	50 MΩ
Frequency	100 kHz	100 kHz		100 kHz	100 kHz	200 kHz	200 kHz
Capacitance	10,000 µF	10,000 µF		10,000 µF	10,000 µF	10,000 µF	10,000 µF
Temperature		+400 °C (752 °F)		Infrared camera -10 °C to +200 °C	+537 °C (998.6 °F)	+1090 °C (1994 °F)	
Conductance/dB						60 nS/-	60 nS/-
Duty cycle/pulse width						•/-	•/-
Continuity/diode test	•	•	•	•	•	•	•
Motor Drive (ASD) Measurements				•	•	•	
VoltAlert™, non-contact voltage detection	• (117)						
VCHECK™							
Lo ohms							
LoZ: low input impedance	• (117)	•	•				
Microamps		•			•	•	•
Display							
Fluke Connect® enabled				•			
Backlight	•	•	•	•		Two level	Two level
Graphical trend display							
Diagnostics and data							
Min/max recording with time stamp	•/-	•/-	•/-	•/-	•/-	•/-	•/-
Display hold/auto (touch) hold	•/-	•/-	•/-	•/•	•/•	•/•	•/•
Relative reference						•	•
Stand-alone logging							
Trend capture							
Readings memories				(with FC app)	(with FC app)		
USB interface							
Other features							
Automatic selection, ac/dc volts	• (117)	•	•				
Infrared camera resolution				80 x 60			
Infrared camera range				-10 °C, +200 °C			
iFlex compatibility				•			
Insulation test voltages					500 V, 100 V, 250 V, 500 V, 1000 V		
PI/DAR timed ratio test					•		
Completely sealed and watertight						•	•
Warranty and electrical safety							
Warranty (years)	3	3	3	3	3	Lifetime/3	Lifetime
Input alert					•	•	•
IP rating	IP42	IP42	IP42	IP40	IP40	IP67	IP67
EN61010-1 CAT III	600 V	600 V	600 V	1000 V	1000 V	1000 V	1000 V
EN61010-1 CAT IV			600 V (113)	600 V	600 V	600 V	600 V

CLAMP METERS

Readings you can rely on

Wires in tight, compact spaces. Panels that are out of reach. Extra-large conductors. We understand your workspace and have designed products for noise-free, reliable readings. Providing advanced performance, the digital clamp meters designed by Fluke are known as workhorse current clamp meters. The amp clamp meter line is simple to use and gimmick free.



FEATURED PRODUCTS



Fluke 376 FC True-rms Clamp Meter

Log and trend measurements to pinpoint intermittent faults

The Fluke 376 FC True-rms Clamp Meter is your go-to tool for an extremely wide range of electrical measurements.

- Connect your meter to your smartphone with Fluke Connect™ Measurements
- Read measurements on your phone at a safe distance, wearing less PPE while your meter takes all the risks
- Record results directly to your phone and the cloud
- Capture intermittent faults while performing other tasks using the logging capabilities of the Fluke 376 FC
- Create and share reports from the field via email, or converse in real time with ShareLive™ video calls
- The iFlex flexible current probe expands the measurement range to 2500 A ac and provides access to large conductors in tight spaces (included)
- TPAK magnetic hanging strap (included)
- Integrated VFD low-pass filter for accurate motor drive measurements
- Proprietary inrush measurement technology to filter out noise and capture motor starting current exactly as the circuit protection sees it
- CAT IV 600 V, CAT III 1000 V safety rating
- Three-year warranty
- Soft carrying case

Fluke 325 True-rms Clamp Meter

Big ac/dc features in a small form factor

The Fluke 325 Clamp Meter performs in the toughest environments and provides noise-free, reliable results. Trust the 325 to help you confidently diagnose all kinds of electrical problems.



- Rugged, reliable true-rms clamp meter with dc current and frequency measurements provides accurate measurements on nonlinear signals
- Measures ac and dc current to 400 A
- Measures ac voltage and dc voltage to 600 V
- Measures resistance to 40 kΩ with continuity detection
- Measures frequency to 500 Hz
- Min/max functionality
- Measures temperature from -10.0 °C to 400.0 °C (14.0 °F to 752.0 °F)
- Measures capacitance to 1000 μF
- Hold function captures a reading on the display
- Features a CAT III 600 V, CAT IV 300 V safety rating
- Two-year warranty

Fluke 902 FC True-rms HVAC Clamp Meter

Helps HVAC technicians work more efficiently on the work site

The Fluke 902 FC Clamp Meter, with Fluke Connect wireless connectivity, can help HVAC technicians improve productivity in the field. The rugged, dual-rated CAT III 600 V, CAT IV 300 V meter equips you to perform many essential HVAC system measurements—microamps for testing pilot light sensors, resistance up to 60 kΩ, ac current and ac/dc voltage, capacitance and contact temperature—all with just one tool.



- A wireless Fluke Connect-enabled clamp meter designed specifically for the needs of HVAC technicians
- Offers 200 μA dc current measurements to measure flame rod
- Extends resistance range to measure thermistors up to 60 kΩ
- Captures flue gas temperature
- Measures start and run motor capacitors
- Measures variable frequency drive performance
- Comes with a TPAK magnetic hanging strap, batteries, soft carrying case, and a three-year warranty
- Measures ac current to 600 A, ac and dc voltage to 600 V, resistance to 60 kΩ
- Measures temperature from -10 °C to 400 °C (14 °F to 752 °F)

CLAMP METER SELECTION GUIDE



Models	Residential/commercial electrical			General purpose		Industrial electrical			HVAC/R
	323	324	325	374 FC	375 FC	365	376 FC	381	902 FC
Measurements									
AC current	•	•	•	•	•	•	•	•	•
AC volts	•	•	•	•	•	•	•	•	•
Resistance	•	•	•	•	•	•	•	•	•
Continuity	•	•	•	•	•	•	•	•	•
DC volts	•	•	•	•	•	•	•	•	•
DC current		•	•	•	•	•	•	•	•
True-rms	•	•	•	•	•	•	•	•	•
Frequency			•		•		•		
AC + DC voltage									
AC + DC current									
Min/max/avg				•	•		•		•
Temperature		•	•						•
Capacitance		•	•	•	•		•		•
Special features									
Fluke Connect™ enabled				•	•		•		•
Inrush current mode				•	•		•	•	
Low-pass filter							•	•	
Harmonics, power, data logging									
18" iFlex Flexible Current Probe				Optional	Optional		Included	Included	
10" iFlex Flexible Current Probe				Optional	Optional		Optional	Optional	
Remote display						Detachable with cable		Detachable magnetic	
Flashlight/torch						•			
Display									
Display hold	•	•	•	•	•	•	•	•	•
Backlight		•	•	•	•	•	•	•	•
Specifications									
Jaw opening	30 mm (1.18")	30 mm (1.18")	30 mm (1.18")	34 mm (1.33")	34 mm (1.33")	18 mm (.7")	34 mm (1.33")	34 mm (1.33")	30.5 mm (1.2")
Current range ac rms	0 to 400.0 A	0 to 400.0 A	0 to 400.0 A	0 to 600.0 A	0 to 600.0 A	0 to 200.0 A	0 to 999.9 A	0 to 999.9 A	0 to 600.0 A
Accuracy ac current (50/60 Hz)	2 % ± 5 counts	2 % ± 5 counts	2 % ± 5 counts	2 % ± 5 counts	2 % ± 5 counts	2 % ± 5 counts	2 % ± 5 counts	2 % ± 5 counts	2 % ± 5 counts
AC response	True-rms	True-rms	True-rms	True-rms	True-rms	True-rms	True-rms	True-rms	True-rms
Current range dc		0 to 400.0 A	0 to 400.0 A	0 to 600.0 A	0 to 600.0 A	0 to 200.0 A	0 to 999.9 A	0 to 999.9 A	0 to 200 µA
Accuracy dc current		2 % ± 5 counts	2 % ± 5 counts	2 % ± 5 counts	2 % ± 5 counts	2 % ± 5 counts	2 % ± 5 counts	2 % ± 5 counts	1 % ± 5 counts
Voltage range ac	0 to 600.0 V	0 to 600.0 V	0 to 600.0 V	0 to 600.0 V	0 to 1000 V	600.0 V	0 to 1000 V	0 to 1000 V	0 to 1000 V
Accuracy ac voltage	1.5 % ± 5 counts	1.5 % ± 5 counts	1.5 % ± 5 counts	1.5 % ± 5 counts	1.5 % ± 5 counts	1.5 % ± 5 counts	1.5 % ± 5 counts	1.5 % ± 5 counts	1.5 % ± 5 counts
Voltage range dc	0 to 600.0 V	0 to 600.0 V	0 to 600.0 V	0 to 1000 V	0 to 1000 V	600.0 V	0 to 1000 V	0 to 1000 V	0 to 600.0 V
Accuracy dc voltage	1 % ± 5 counts	1 % ± 5 counts	1 % ± 5 counts	1 % ± 5 counts	1 % ± 5 counts	1.5 % ± 5 counts	1 % ± 5 counts	1 % ± 5 counts	1 % ± 5 counts
Resistance range	0 to 4000 Ω	0 to 4000 Ω	0 to 40.00 kΩ	0 to 6000 Ω	0 to 60 kΩ	0 to 6000 Ω	0 to 60 kΩ	0 to 60 kΩ	0 to 60 kΩ
Frequency measurement range			500 Hz		500 Hz		500 Hz	500 Hz	
Unit power									
Auto off	•	•	•	•	•	•	•	•	•
Warranty and safety									
Warranty (years)	2	2	2	3	3	3	3	3	3
Category ratings (EN61010-1)	CAT III 600 V, CAT IV 300 V	CAT III 600 V, CAT IV 300 V	CAT III 600 V, CAT IV 300 V	CAT III 1000 V, CAT IV 600 V	CAT III 1000 V, CAT IV 600 V	CAT III 600 V	CAT III 1000 V, CAT IV 600 V	CAT III 1000 V, CAT IV 600 V	CAT III 600 V, CAT IV 300 V



Models	High-end industrial/utility			iFlex accessory*	Leakage	
	345	353	355	i2500-10/ i2500-18	368 FC	369 FC
Measurements						
AC current	•	•	•	•	•	•
AC volts	•		•			
Resistance			•			
Continuity			•			
DC volts	•		•			
DC current	•	•	•			
True-rms	•	•	•	•		•
Frequency	•	•	•	•		
AC + DC voltage			•			
AC + DC current		•	•			
Min/max/avg		•	•	•	•	•
Temperature						
Capacitance						
Special features						
Fluke Connect™ enabled					•	•
Inrush current mode	•	•	•	•		
Low-pass filter		•	•			
Harmonics, power, data logging	•					
18" iFlex Flexible Current Probe						
10" iFlex Flexible Current Probe						
Remote display						
Flashlight/torch						•
Display						
Display hold		•	•		•	•
Backlight	•	•	•		•	•
Specifications						
Jaw opening	60 mm (2.36")	58 mm (2.28")	58 mm (2.28")	7.5 mm (.59")coil	40 mm (1.57")	61 mm (2.40")
Current range ac rms	0 to 1400	0 to 1400 A	0 to 1400 A	0 to 2500 A	0 to 60 A	0 to 60 A
Accuracy ac current (50/60 Hz)	3 % ± 5 counts	1.5 % ± 5 counts	1.5 % ± 5 counts	3 % ± 5 counts	1 % ± 5 counts	1 % ± 5 counts
AC response	True-rms	True-rms	True-rms	True-rms	True-rms	True-rms
Current range dc	0 to 2000	0 to 2000 A	0 to 2000 A			
Accuracy dc current	1.5 % ± 5 counts	1.5 % ± 5 counts	1.5 % ± 5 counts			
Voltage range ac	0 to 825 V		0 to 600.0 V			
Accuracy ac voltage	3 % ± 5 counts		1 % ± 5 counts			
Voltage range dc	0 to 825 V		0 to 1000 V			
Accuracy dc voltage	1 % ± 5 counts		1 % ± 5 counts			
Resistance range			0 to 400 kΩ			
Frequency measurement range	15 Hz to 1 kHz	5 to 1000 Hz	5 to 1000 Hz	500 Hz		
Unit power						
Auto off		•	•		•	•
Warranty and safety						
Warranty (years)		3	3	3	1	1
Category ratings (EN61010-1)	CAT IV 600 V	CAT III 1000 V, CAT IV 600 V	CAT III 1000 V, CAT IV 600 V	CAT III 1000 V, CAT IV 600 V	CAT III 600 V	CAT III 600 V

*Clamp not included

CONDITION MONITORING

Step up to connected reliability



In every work environment, there are multiple examples of rotating machinery—such as motors, pumps, compressors, and fans. Assets experience common issues and performance degradation over time, ultimately leading to a failure. Something changed before the breakdown, indicating an impending problem. Tracking these changes allows teams to identify the root cause earlier.

Condition monitoring (CM) gathers and records asset data over time. Understanding the performance of assets helps you prioritize actions, schedule maintenance, and extend the life of your equipment.

Two of the CM testing modes effective for early detection are vibration monitoring and power monitoring. Vibration monitoring detects imbalance, looseness, misalignment, and bearing wear, while power monitoring measures variables to find the cause of electrical and mechanical issues. Both provide maintenance professionals with clear and quantifiable metrics to determine current status and needed actions.





Fluke 3561 FC Vibration Sensors with Gateway

Minimize maintenance routes and extend asset life by observing triaxial measurements from Fluke 3561 FC Vibration Sensors via Fluke Connect™ Condition Monitoring software.

- Wireless, compact sensors for a scalable, remote monitoring solution
- Alarms based on user-defined or Fluke Overall Vibration Severity (FOVS) scale thresholds
- Capture rate: One data point every 90 seconds
- Visualize data with software trending and graphing
- Remotely view real-time and historical triaxial vibration, surface temperature data
- Choose from one- or three-year software licenses (where applicable)
- Battery life: three years (varies by usage)
- Size:
 - Sensor: (H x W) 61.5 mm x 24 mm
 - Gateway: (H x W x L) 57.3 mm x 39.3 mm x 46.5 mm
- Frequency response range: 10 to 1,000 Hz
- Bluetooth type: Low Energy 4.1
- IP Rating: IP 67



Fluke 3540 FC Three-Phase Power Monitor Kit

Monitor equipment for changes in key electrical variables. Current, voltage, frequency and energy consumption fluctuate when machinery experiences excess load.

- Measures:
 - Single, split or three-phase loads
 - Voltage, current, and frequency
 - Active power, nonactive power, and power factor
 - Total harmonic distortion
- Wireless data collection or internal memory sufficient for one week with one second data intervals
- Remotely monitor real-time and historical power variable data
- Visualize data with software trending, graphing, and timeboxing
- Auto-generated alarms when power variables deviate from preset thresholds
- Power options: Battery, power supply, or power from the measurement line
- Size: (W x H x D) 19.8 cm x 16.7 cm x 5.5 cm
- IP Rating: IP 50; IEC 60529



BENCH MULTIMETERS

Fluke Calibration digital bench multimeters have the precision and versatility to handle the most demanding measurements, on the bench or in a system. These benchtop DMMs are easy to use and offer excellent value that makes them an ideal solution for many applications. Standards laboratory DMMs include: Reference multimeters, precision digital multimeters, and bench multimeters.



FEATURED PRODUCTS AND SELECTION GUIDE



Fluke Calibration 8845A/8846A 6.5 Digit Precision Bench Multimeters

6.5 digit precision and versatility for bench or systems applications

- 6.5 digit resolution
- Basic V dc accuracy of up to 0.0024 %
- Dual display
- 100 µA to 10 A current range, with up to 100 pA resolution
- Wide ohms range from 10 Ω to 1 GΩ with up to 10 µΩ resolution
- 2 x 4 ohms four-wire measurement technique
- Both models measure frequency and period
- The 8846A also measures capacitance and temperature
- USB memory drive port (8846A)
- Fluke 45 and Agilent 34401A emulation
- Graphical display
- TrendPlot™ paperless recorder mode, statistics and histogram
- CAT I 1000 V, CAT II 600 V
- Three-year warranty



Fluke Calibration 8808A 5.5 Digit Multimeter

Versatile 5.5 digit multimeter for manufacturing, development and service applications

- 5.5 digit resolution
- Basic V dc accuracy of 0.015 %
- Dual display
- Dedicated dc leakage current measurement
- 2 x 4 ohms four-wire measurement technique
- Six dedicated buttons for fast access to instrument setups
- Hi/lo limit compare for pass/fail testing
- Three-year warranty

Models	8808A	8845A	8846A
Specifications			
Display	dual	dual, graphical	
Resolution (Number of digits)	5.5	6.5	
Measurements	V ac, V dc, I dc, I ac, Ω, Cont, Diode	V ac, V dc, I dc, I ac, Ω, Continuity, Diode	
Basic V dc accuracy (% Reading + % Range)	0.015 + 0.003	0.0035 + 0.0005	0.0024 + 0.0005
Advanced measurements/functions	2x4 wire ohms, freq, i-Leakage dedicated setup keys	2x4 wire ohms, frequency, period	2x4 wire ohms, frequency, period, capacitance, temp (RTD)
Math	Null, dBm, dB, Min, Max	Null, dBm, dB, Min, Max, Average, Std Deviation, MX+B	
Analysis	Limit compare	Limit compare, TrendPlot, Histogram, Statistics	
USB memory device port			•
Interfaces	RS-232, USB via optional adapter	RS-232, IEEE-488.2, LAN, USB via optional adapter	
Ordering information			
Included accessories	Power cord, test lead set, programmer's manual/user's manual on CD, FVF-BASIC, FlukeView Forms Software Basic Version	Power cord, test lead set, programmer's manual/user's manual on CD, FVF-BASIC, FlukeView Forms Software Basic Version	Test leads, line cord, getting started guide, user's manual on CD

LAYOUT AND DISTANCE

Level. Layout. Build.™

PLS laser levels and Fluke laser distance meters are the professional contractor's tool of choice for accurate layout and measurement on the job site. Rugged, portable, and accurate, PLS and Fluke tools will save you time and money compared to traditional layout methods using tape measures, bubble vials, plumb bobs, or complex measurements and calculations.

PLS laser levels give you the highest-quality bright, thin, and crisp lines and dots for accurate reference and layout applications. To handle the rigors of a job site, PLS laser levels are drop tested up to 1 meter, IP54 rated to protect against water and dust ingress, and covered with a best-in-class, three-year warranty. PLS lasers are self-leveling and designed with the professional contractor in mind.

A PLS laser level, combined with a compact, easy-to-use Fluke laser distance meter, will provide a lifetime of increased productivity, quality, and profit. You get the tools to do the work right the first time, preventing costly rework and callbacks.



FEATURED PRODUCTS

PLS 180G KIT Green Crossline Laser Level

Fast, accurate level and plumb reference for construction

Chalk-free lines for installation

This professional, self-leveling, crossline green laser level provides horizontal and vertical lines with $\leq 3 \text{ mm @ } 10 \text{ m}$ ($\leq 1/8 \text{ in. at } 30 \text{ ft.}$) accuracy, allowing for fast, accurate, level and plumb reference lines for fixture alignment, conduit and ductwork installation, wall construction, acoustic ceiling installation, tile installation, and general residential and commercial construction.

Longer distance and use in bright light

Daylight and brighter interior lighting can wash out the visibility of laser lines. For use outdoor, or in an area with bright overhead lighting, use the laser level with an optional detector to increase the visible range of the laser. Additionally, the PLS 180G green beam laser level appears up to three times brighter than the PLS 180R red beam laser level, making it ideal for projects over longer distances or with undesirable lighting conditions.

Durability for the job site

Backed with an industry-leading three-year warranty, PLS laser levels are designed with the professional contractor in mind. PLS laser levels withstand a 1 m drop test, feature a pendulum lock to prevent damage in transport and resist water and dust with an IP54 rating.



PLS 3G KIT Green 3 Point Laser Level

Fast, accurate layout of reference points

Accurate reference points

This professional, self-leveling, three-point green laser level provides reference points with $\leq 3 \text{ mm @ } 10 \text{ m}$ ($\leq 1/8 \text{ in. at } 30 \text{ ft.}$) accuracy, allowing for fast, accurate layout of reference points for steel stud framing, HVAC installation and electrical and residential construction.

Green vs. red

The PLS 3G green beam laser appears up to three times brighter than the PLS 3R red beam, making it ideal for projects over longer distances or with undesirable lighting conditions.

Durability for the job site

Backed with an industry-leading three-year warranty, PLS laser levels are designed with the professional contractor in mind. PLS laser levels withstand a 1 m drop test, feature a pendulum lock to prevent damage in transport, and resist water and dust with an IP54 rating.



Fluke 424D Laser Distance Meter

Measure farther, with greater accuracy, in more situations

Extend your reach with high accuracy

You can use the Fluke 424D Laser Distance Meter to measure up to 100 m (330 ft.), accurate to $\pm 1 \text{ mm}$ ($\pm .040 \text{ in.}$). No scales to interpret or misread. The extra bright laser makes it easy to target even at long distances and the backlit display makes it easy to read the results. The 424D will help you save time and reduce errors with enhanced features like storage for 20 complete displays, indirect Pythagoras distance calculations and the tripod mode for stable, long-distance measurements. No matter your job, the 424D Laser Distance Meter provides accurate, long-distance measurements to help you do the work of two people on your own.



PLS LASER LEVEL SELECTION GUIDE

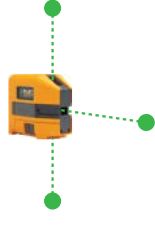
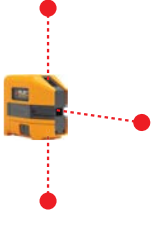
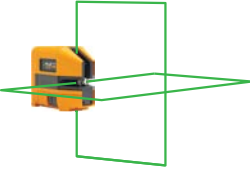
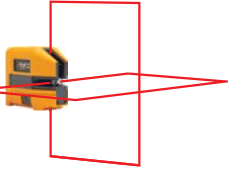

Models	PLS 3G KIT	PLS 3R KIT	PLS 180G KIT	PLS 180R KIT
Laser function				
Laser type	3-point	3-point	Crossline	Crossline
Laser color	Green	Red	Green	Red
Accuracy	≤ 3 mm @ 10 m (≤ 1/8 in. at 30 ft.)	≤ 3 mm @ 10 m (≤ 1/8 in. at 30 ft.)	≤ 3 mm @ 10 m (≤ 1/8 in. at 30 ft.)	≤ 3 mm @ 10 m (≤ 1/8 in. at 30 ft.)
Batteries	(3) AA alkaline	(3) AA alkaline	(3) AA alkaline	(3) AA alkaline
Included in box				
Laser level	PLS 3G Z	PLS 3R Z	PLS 180G Z	PLS 180R Z
Canvas pouch	•	•	•	•
PLS BP5 alkaline pack	•	•	•	•
PLS FS floor stand	•	•	•	•
PLS MLB wall bracket	•	•	•	•
Reflective target	•	•	•	•
PLS C18 carrying case	•	•	•	•
PLS UB9 wall/ceiling bracket	•	•	•	•
Application guide				
Electrical	•	•	•	•
HVAC	•	•	•	•
Framing	•	•	•	•
Finish carpentry	•	•	•	•
Foundations			•	•
Floor and tile			•	•
Acoustic ceiling			•	•
Painting			•	•
Window and glass	•	•	•	•
Other configuration				
Tools and pouch only	PLS 3G Z	PLS 3R Z	PLS 180G Z	PLS 180R Z
KIT with detector			PLS 180G SYS	PLS 180R SYS

DISTANCE METERS SELECTION GUIDE



Models	Fluke 424D	Fluke 419D	Fluke 417D
Maximum measurement distance	100 m (330 ft)	80 m (260 ft)	40 m (131 ft)
Accuracy	± 1 mm (± 0.04 in)	± 1 mm (± 0.04 in)	± 2 mm (± 0.08 in)
Battery life (number of measurements)	5000	5000	3000
Drop test			1 m (3 ft.)
Area measurement	•	•	•
Volume measurement	•	•	
Pythagoras calculation	Full	Full	
Plus and minus calculations	•	•	
Measurement storage	20 complete displays	20 complete displays	
Min/max	•	•	
Tripod mount	•	•	
Corner angle measurement	•	•	
IP rating	IP54	IP54	IP54
Inclination sensor	•		
Display	4 line	3 line	2 line
Automated end-piece correction	•	•	
EN 60825-1: 2007 (Class II compliant)	•	•	•
Included in box			
Distance meter	Fluke 424D	Fluke 419D	Fluke 414D
Two AAA batteries	•	•	•
Vinyl carrying pouch	•	•	•
Other configurations			
Kit with a non-contact thermometer			Fluke 414D/62 Max+ Kit

EARTH GROUND TESTERS

It's critical for facilities to have grounded electrical systems, so that in the event of a lightning strike or utility overvoltage, current will find a safe path to earth. To ensure a reliable connection to earth, it's recommended that ground electrode testing be performed at regular intervals.

Fluke's family of electrical earth ground testers have been built to address the entire spectrum of ground-testing methods from the basic to the most advanced. Our testers have been designed to be accurate, safe and easy to use. We provide quick and precise resistance measurements through several test methods: 3- and 4-pole fall-of-potential testing, selective measurement testing, stakeless testing and 2-pole testing.





Fluke 1630-2 FC Earth Ground Clamp

Earth ground ac leakage current measurement

- Identify ac leakage currents without disconnecting the earth ground stake from the grounding system
- Save time by automatically recording data at preset intervals. Stores up to 32,760 measurements at the set logging interval
- Share stored data with Fluke Connect™
- User-defined high/low alarm limits, for rapid measurement evaluation
- Selectable band-pass filter function removes unwanted noise from the ac leakage current measurement



Fluke 1625-2 GEO Earth Ground Tester

Fast, accurate earth ground testing using all four test methods

- A unique earth ground tester that performs testing with and without stakes
- Tests 3- and 4-pole fall-of-potential, and 4-pole soil resistivity (with stakes)
- Performs selective earth ground rod testing (one clamp + stakes)
- Performs stakeless earth ground rod testing (two clamps)
- Features Automatic Frequency Control (AFC) to minimize the effect of interference



Models		1623-2	1625-2	1630-2 FC
Specifications				
Fall of potential	3-pole	•	•	
	4-pole/soil	•	•	
Selective	1 clamp	•	•	
Stakeless	2 clamp	•	•	•
2-pole method	2-pole	•	•	
Automatic Frequency Control (AFC) 94 Hz to 128 Hz			•	
R* measurement (55 Hz)			•	
Adjustable limits			•	
Memory		•	•	•
AC leakage current				•

MULTIFUNCTION INSTALLATION TESTERS

Fluke's Multifunction Installation Testers are built to test fixed wiring installations based on the IEC 60364-6 regulation, and all your local equivalent standards. The Fluke 1660 Series Installation Testers are the only installation testers that help prevent damage to connected appliances, and also allow users to send test results wirelessly via smartphone directly from the field.

Insulation Pretest (1664 FC only)

Protect the installation and avoid costly mistakes. If the tester detects that appliances are connected to the system during test, it will stop the insulation test and provide a visual and audible warning.

Auto test (1664 FC only)

Reduce test time up to 40 %, reduce the number of manual connections and decrease the possibility of making errors. Do all required installation tests in ONE sequence, ensuring compliance with local installation regulations.

Fluke Connect™ compatible (1664 FC only)

Save time without losing information. Eliminate data entry by wirelessly syncing measurements directly from your installation tester. Retrieve stored results from the office or in the field to make decisions in real time.



FEATURED PRODUCTS



Fluke 1664 FC Multifunction Installation Tester

Get more from your installation tester. The only tester with “Insulation PreTest” that stops you from performing tests with appliances that are connected to the system during test. This helps eliminate accidental damage and keeps your customers happy. In addition, it offers you Fluke Connect and Auto Test.

The 1664 FC puts more power in your hands by quickly and efficiently testing to all local regulations, protecting appliances that may be inadvertently connected to the system under test, and making it easy to share test results over your smartphone.



Fluke 1663 Multifunction Installation Tester

Ideal for professional trouble-shooters. Operation is intuitive and easily mastered by all levels of field workers. This instrument is ideal for professional users—high-end functionality, advanced measurement capability, yet it is still easy to use.

The Fluke 1663 puts more power in your hands by quickly and efficiently testing to all local regulations.



Fluke 1662 Multifunction Installation Tester

A solid, basic installation tester. Get Fluke’s reliability, simple operation and all the testing power you need for day-in, day-out installation testing. It tests to all local regulations and is easy and intuitive to use. Additional helpful features like the On/Off switchable auto-start for RCD and loop test, and self-test save time and give you more confidence in your results.

MULTIFUNCTION INSTALLATION TESTERS SELECTION GUIDE



Models	1664 FC	1663	1662
Basic features			
Insulation-PreTest™ safety function	•		
Insulation at L-N, L-PE, N-PE inputs	•		
Auto Test sequence	•		
Loop and line resistance—mΩ resolution	•		
Continuity at L-N, L-PE, N-PE inputs	•	•	
Test smooth dc sensitive RCDs (Type B/B+)	•	•	
Earth resistance	•	•	
Voltage trms (ac and dc) and frequency	•	•	•
Wiring polarity checker, detects broken PE and N wires	•	•	•
Insulation resistance	•	•	•
Continuity and resistance	•	•	•
Measure motor windings with continuity test (@ 10 mA)	•	•	•
Loop and line resistance	•	•	•
Prospective Earth Fault Current (PEFC/IK)	•	•	•
Prospective Short-Circuit Current (PSC/IK)	•	•	•
RCD trip time	•	•	•
RCD trip current (ramp test)	•	•	•
Measures trip time and current for RCD type A and AC in one test	•	•	•
RCD variable test current	•	•	•
Automatic RCD test sequence	•	•	•
Phase sequence test	•	•	•
Z Max Memory	•	•	
Memory	•	•	•
IR-USB and BLE interface (when used with optional Fluke DMS and FVF software)	IR-USE/BLE	IR-USB	IR-USB

PORTABLE APPLIANCE TESTERS

The Fluke 6500-2 and 6200-2 enable you to work faster without compromising safety—yours, your colleagues or your customer's. Perform measurements according to the local standards. Portable appliance testing (PAT testing) is crucial for maintaining electrical safety in any workplace. This could be driven by legislations involving aspects of health and safety, or by the insurance market. All employers have a duty of care.

One-touch testing

Test appliances easier and without setting up any test procedures. Pre-set test routines are initiated from a single button, ideal for service and repair applications.

Auto-test sequences (6500-2 only)

Test appliances faster and more effective at periodic testing—increased user convenience. Pre-defined test sequences and pre-set pass/fail levels allow reliable and safe appliance testing.

Optimal user interface

Test appliances simpler than ever. Get better readings from the bright and colored display, test faster thanks to the single mains socket. These and many other features that simplify your daily tasks.



FEATURED PRODUCTS



Fluke 6200-2 Portable Appliance Tester

The Fluke 6200-2 PAT tester offers you one-touch testing to help you test appliances easier, without setting up test procedures. This will help you complete more portable appliance tests per-session, ideal for service and repair applications.

The Fluke 6200-2 offers:

- Dedicated key for each test for 'one touch' testing
- Pre-set pass/fail levels to save time
- Large backlit display for easy reading
- Single mains socket for appliance connection
- Separate IEC socket for easy mains/ extension lead testing
- Detachable test leads for quick field replacement
- Integral carrying handle
- USB port for data transfer



Fluke 6500-2 Portable Appliance Testers

The Fluke 6500-2 PAT tester gives you enhanced functions such as the AUTO test feature, to help you complete more portable appliance tests per-session. Packed with all the features you need for testing portable appliances, this is the complete all-in-one solution for portable appliance testing.

The Fluke 6500-2 delivers all the capabilities from the 6200-2, plus:

- Integral QWERTY keyboard for rapid data entry
- Additional USB memory capability for back-up data storage and transfer to PC
- Large backlit graphics display for easy reading
- Pre-set, auto-test sequences for user convenience
- Integral site, location and description codes for faster data processing
- Memory review facility for more onsite control

Separate hard case

The compact Fluke PAT testers are supplied with a hard-carrying case that not only offers protection during transit but also includes extra storage space for accessories and other tools. The PAT testers are extremely light, weighing approximately 3 kg (without case) and have integral carrying handles for extra convenience.

Not available in all countries

PAT SELECTION GUIDE



Models	6200-2	6500-2
Basic features		
LN mains volts	•	•
Outside limits indicators	•	•
Null out facility for earth bond lead	•	•
Protective earth resistance PE (200 mA)	•	•
Protective earth resistance PE (25 mA)	•	•
Insulation 500 V dc	•	•
Insulation 250 V dc		•
Protective earth conductor current	•	•
Touch current	•	•
RCD test		•
Substitute leakage current	•	•
Appliance power kVA	•	•
Appliance load current	•	•
Seven segment custom LCD	•	•
Color dot matrix display		•
Back light	•	•
USB port for printing	•	•
USB flash drive port (storage and download)		•
External printer output	•	•
Front panel QWERTY key pad		•
IEC lead test	•	•
Auto-testing		•
Pass/Fail level programmable indicators		•
Data storage		•
Limited data storage	•	
Polarity checks		•
Graphical help menu on line		•
Programme mode		•
Real time clock		•
Front panel results management		•
230 V test socket/230 V mains input power plug	•	•
110 V appliance test compatible with test lead adapter		•

ELECTRICAL TESTERS

The first tool you reach for

Often the first tool you reach for when troubleshooting an electrical problem is an electrical tester. An electrical tester is a frontline troubleshooting tool designed to give you quick results, so you can quickly get equipment up and running again. Whether you're checking for the presence of voltage, measuring voltage without making metallic contact, measuring current or checking continuity and resistance levels, a tester is fast, reliable and easy to use. Its compact form means you can carry an electrical tester with you, whether in your shirt pocket, pants pocket or tool belt, for fast access.

When complemented with accessories such as a proving unit, a carrying case, a belt holster, alligator clips or a spare set of test leads, an electrical tester will be your go-to tool for any job.



FEATURED PRODUCTS



Fluke T6-1000 Electrical Tester

Measure voltage...without test leads

Measure voltage up to 1000 V ac through the open fork, without test lead contact to live voltage. Equipped with revolutionary FieldSense technology, the T6-1000 can make true-rms ac voltage measurements just by placing the wire to be measured in the open fork. The ability to simultaneously measure up to 1000 V ac and 200 A on wires up to AWG 4/0 (120 mm²) makes the T6-1000 an extremely versatile front-line troubleshooting tool. Plus, the ability to measure frequency through the open fork with just the push of a button gives you even more information at your fingertips.

For more traditional measurements, the included test leads still allow you to measure ac or dc voltage up to 1000 V or resistance up to 100 kΩ.

Related products and accessories

- Fluke AC285 SureGrip™ Alligator Clips
- Fluke H-T6 Holster
- Fluke TPAK Magnetic Meter Hanger



Fluke T150/T130/T110/T90 Two-pole voltage and continuity testers

The four Fluke two-pole voltage and continuity testers are built to work the way you work. They give you the best combination of safety, ease-of-use and fast answers available anywhere.

Designed according to both regulation HSE GS 38 (tip caps) and IEC EN 61243-3:2014 to verify the absence of voltage – even with discharged batteries. CAT IV 600 V, CAT III 690 V safety rating

With 4 ways to indicate the presence of voltage—LED indicator, LCD display, audible tone or tactile feedback, always know if hazardous voltage is present (digital display on T130, T150, vibration indicator on T110, T130, T150)

- **Fluke T150 Voltage and Continuity Tester** with LCD readout and additional resistance measurement
- **Fluke T130 Voltage and Continuity Tester** with backlit LCD readout
- **Fluke T110 Voltage, Continuity Tester** with switchable load
- **Fluke T90 Basic Voltage and Continuity Tester**

Fluke 1AC II VoltAlert™ Electrical Tester

Easy to use and small enough to fit in your shirt pocket, the 1AC II VoltAlert allows electricians, maintenance technicians, service and safety personnel and homeowners to quickly test for energized circuits. Certified up to CAT IV 1000 V, the 1AC II illuminates red and emits an audible alert in the presence of 90–1000 V ac. Designed with Voltbeat™ technology, the 1AC II performs a continuous self-test, so you always know it's working. The convenient pocket clip allows you to easily carry it around in your shirt pocket yet always have it at the ready to check for the presence of voltage. Also available in a 20–90 V ac version for use on control circuits.



ELECTRICAL TESTERS SELECTION GUIDE



Models	Open fork testers with FieldSense technology		Classic open fork testers		Phase rotation indicator
	T6-1000	T6-600	T5-1000	T5-600	9040
Basic features					
FieldSense voltage measurement technology	•	•			
Open fork design	•	•	•	•	
True-rms readings	•	•			
Frequency range/Rotary field indication					15-400 Hz / •
Measurements					
Voltage ac/dc	1000 V	600 V	1000 V	600 V	40-700 V ac
Current ac	200 A	200 A	100 A	100 A	
Resistance/Frequency	100 k Ω / 45-66 Hz	2000 Ω / -	1000 Ω / -	1000 Ω / -	
Continuity test	•	•	•	•	
DC polarity indicator	•	•	•	•	
Display					
LCD readout	•	•	•	•	•
Backlight	•	•			
Dual line display—simultaneous V+I, Hz	•				
Other features					
Hazardous voltage warning light	•	•	•	•	
Warranty and electrical safety					
Warranty (years)	2	2	2	2	2
Safety rating (EN 61010) CAT III	1000 V	600 V	1000 V	600 V	600 V
Safety rating (EN 61010) CAT IV	600 V		600 V		300 V



Models	Two-pole voltage and continuity testers			
	T90	T110	T130	T150
Voltage ac/dc	12 V to 690 V		6 V to 690 V	
Continuity/Frequency	0 to 400 k Ω / 0/40 to 400 Hz			
Phase rotation	-		100 V to 690 V	
Resistance measurement	-	-	-	Up to 1999 Ω
Response time (LED ladders)	< 0,5 s			
200 k Ω input impedance	Current draw 3,5 mA @ 690 V Current draw 1,15 mA @ 230 V			
7k Ω input impedance (with load buttons pressed)	Current draw 30 mA @ 230 V			
Safety rating	CAT II 690 V CAT III 600 V		CAT III 690 V CAT IV 600 V	
IP rating	IP54		IP64	
Warranty (years)	2			



Models	Fluke VoltAlert™ family			
	1AC II	2AC	LVD2	LVD1
Basic features				
Voltage range	90 V ac to 1000 V ac	90 V ac to 1000 V ac	90 V ac to 600 V ac	40 V ac to 300 V ac
On/off	•	Always on	•	•
Audible alert	•			
Flashlight			•	•
Dual sensitivity			•	•
Warranty (years)	2	2	2	1
Safety rating	CAT IV 1000 V	CAT IV 1000 V	CAT IV 600 V	

INDOOR AIR QUALITY

IAQ monitoring and measurement

Fluke indoor air quality tools are the professional's choice for maintaining, troubleshooting, and adjusting the heating and air conditioning systems of our offices, schools, hospitals, manufacturing plants, data centers, and other facilities. Diagnosing potential environmental irritants and hazards allows for adjustments and countermeasures to solve or prevent issues like sick building syndrome.

Indoor air diagnostics, temperature, humidity, air flow, particle concentration, and other measurements are used in the balancing and maintenance of a HVAC system. With the quality and measurement accuracy of Fluke tools, you can quickly diagnose, identify, and begin to resolve indoor air quality issues.

Fluke's professional indoor air diagnostic tools like the Fluke 985 Airborne Particle Counter, are essential for every HVAC technician and facility maintenance manager. With the Fluke 985, the user is provided with real-time particle concentration measurement for use in diagnosing and identifying the source of an airborne contamination.



FEATURED PRODUCTS



Fluke 985 Airborne Particle Counter

Portable, handheld particle measurement

Take a new look at indoor air quality.

The Fluke 985 Airborne Particle Counter is the preferred choice for HVAC and IAQ professionals. From filter testing to IAQ investigations, the Fluke 985 is the portable solution for determining airborne particle concentrations. Use the Fluke 985 to immediately respond to occupant complaints, or as part of a comprehensive preventive maintenance program.

Use the Fluke 985 Particle Counter to:

- Measure filter efficiency
- Monitor industrial clean rooms
- Prescreen indoor air quality and confidently work with IAQ specialists
- Locate particle sources for remediation in a particular location
- Report the effectiveness of repairs to customers
- Drive additional business by demonstrating the need for maintenance and repair

The Fluke 985 is lightweight and easy to use in any position. Data export options use a USB cable or memory stick, so it's easy to review and analyze the data anywhere and anytime.



Fluke 971 Temperature Humidity Meter

Fast, accurate ambient temperature and humidity measurements

Temperature and humidity monitoring

Temperature and humidity are two important factors in maintaining optimal comfort levels and good indoor air quality (IAQ). Quickly and conveniently take accurate humidity and temperature readings with the Fluke 971.

Durable and portable

The Fluke 971 is invaluable for facility maintenance and utility technicians, HVAC-service contractors and specialists who assess indoor air quality. Lightweight and easy to hold, the Fluke 971 is the perfect tool for monitoring problem areas.



Fluke 975 AirMeter™

Simple, all-in-one air diagnostics

One tool. Get more done.

The Fluke 975 AirMeter test tool raises indoor air monitoring to the next level by combining five powerful tools into one rugged and easy-to-use handheld device. Use the Fluke 975 to optimize HVAC ventilation settings for ASHRAE 62 recommendations, to actively monitor conditions that promote a productive environment and quickly and accurately address occupant comfort complaints the first time. The Fluke 975 measures:

- Temperature
- Velocity
- Humidity
- CO²
- CO

Use the Fluke 975 AirMeter test tool to:

- Respond to comfort-related calls from occupants
- Verify the operation of building HVAC control systems
- Determine whether adequate ventilation exists for space air cycling
- Monitor air flow and velocity
- Test for dangerous carbon monoxide leaks

INDOOR AIR QUALITY SELECTION GUIDE



Models	Fluke 971	Fluke 922 and Fluke 922/Kit	Fluke 975 and Fluke 975V	Fluke 985	Fluke CO-220
Record storage	99	99	25,000 records (continuous), 99 records (discrete)	10,000	
Downloadable data	No	No	Yes	USB or Ethernet	No
Battery type	(4) AAA	(4) AA	Rechargeable Li-Ion (primary), (3) AA (backup)	Rechargeable Li-Ion 7.4 V 2600 mAh	(1) 9V
Warranty	2 years	2 years	2 years	1 year	1 year
Indoor air diagnostic applications					
Air velocity		•	•		
Air pressure		•			
Air flow (volume)		•			
Carbon dioxide					
Carbon monoxide					•
Temperature	•	•	•		
Humidity	•	•	•		
Dew point/wet bulb	•		•		
Particle concentration counting				•	
Air pressure/air velocity/air flow					
Air pressure range		± 4000 Pascals/±16 inH ₂ O/± 400 mmH ₂ O/± 40 mbar/± 0.6 psi			
Air pressure accuracy		± 1% + 1 Pascal/± 1% + 0.01 inH ₂ O/± 1% + 0.1 mmH ₂ O/± 1% + 0.01 mbar/± 1% + 0.0001 psi			
Air velocity range		250 to 16,000 fpm/1 to 80 m/s	50.0 fpm to 3000 fpm/0.25 m/s to 15 m/s		
Air velocity accuracy		± 2.5% of reading at 2000 fpm (10.00 m/s)	± 4.0% of reading above 50 fpm (0.25 m/s)		
Air flow (volume) range		0 to 99,999 cfm			
Air flow (volume) accuracy		Accuracy is a function of velocity and duct size			
Temperature relative humidity					
Temperature range	-20 °C to 60 °C (-4 °F to 140 °F)	0 °C to 50 °C (32 °F to 122 °F)	-20 °C to 50 °C (-5 °F to 122 °F)		
Temperature accuracy	0 °C to 45 °C (± 0.5 °C)/-20 °C to 0 °C and 45 °C to 60 °C (± 1.0 °C) 32 °F to 113 °F (± 1.0 °F)/-4 °F to 32 °F and 113 °F to 140 °F (± 2.0 °F)	0 °C to 50 °C (± .01 °C) 32 °F to 122 °F (± .01 °F)	40 °C to 60 °C (± 0.9 °C)/5 °C to 40 °C (± 0.5 °C)/-20 °C to 5 °C (± 1.1 °C) 114 °F to 140 °F (± 1.6 °F)/40 °F to 113 °F (± 1.0 °F)/-5 °F to 113 °F (± 1.98 °F)		
Relative humidity range	5% to 95% RH	0% to 90% RH	10% to 90% RH		
Relative humidity accuracy	10% to 90% RH @ 23 °C (73.4 °F) (± 2.5% RH) < 10%, > 90% RH @ 23 °C (73.4 °F) (± 5.0% RH)	0% to 90% RH @ 23 °C (73.4 °F) (± 2.0% RH)	10% to 90% RH @ 23 °C (73.4 °F) (± 2.0% RH)		
Carbon dioxide/carbon monoxide					
Carbon dioxide range			0 to 5000 ppm		
Carbon dioxide accuracy			2.75% + 75 ppm		
Carbon monoxide range			0 to 500 ppm		0 to 1000 ppm
Carbon monoxide accuracy			± 5% or ± 3 ppm, whichever is greater, @ 20 °C (68 °F) and 50% RH		5% or ± 2 PPM
Particle counting					
Flow rate				2.83 L/min (0.1 cfm)	
Particle size range				0.3 µm - 10.0 µm (6 channel)	
Count modes				Raw counts, #/m ³ , #/ft ³ , #/liter in Cumulative or Differential mode	
Counting efficiency				50% @ 0.3 µm; 100% for particles > 0.45 µm (per ISO 21501)	
Concentration limits				10% at 4,000,000 particles per ft ³ (per ISO 21501)	

INSULATION TESTERS

Critical readings, quickly and safely

Whether you work on motors, generators, cables or switch gear, the Fluke insulation resistance testers provide noise-free, reliable results. Delivering advanced performance, the insulation tester line is safe, simple to use and gimmick-free. It's a perfect solution for troubleshooting, commissioning and preventative maintenance applications.



FEATURED PRODUCTS AND SELECTION GUIDE

INSULATION TESTERS



Fluke 1587 FC Insulation Multimeter

Keep yourself safe. Find hidden problems faster. Put the paperwork down.

Fluke Connect™ plus Fluke's 1587 FC Insulation Multimeter helps you identify tough problems, fix them and wirelessly communicate your work through your smartphone—all at a safe distance from hazardous areas.

PI/DAR timed ratio tests with TrendIt™ graphs identify moisture and contaminated insulation problems fast. Fluke Connect saves measurements, eliminates the need to write down results, reduces errors and saves data for historical tracking. Temperature compensation helps create accurate baselines. Includes live circuit detection to prevent an insulation test if voltage >30 V is detected, and a VFD low-pass filter.



Fluke 1550C Insulation Tester

Evaluate the trends, eliminate the doubt.

The Fluke 1550C insulation resistance testing FC kit offers digital insulation testing up to 5 kV. And with the Fluke Connect wireless app, you can perform tests and collect data from a safe distance. Quickly configure, start and stop tests on the 1550C remotely, a safe distance away from any operating, energized equipment. Remote data collection saves test results to the cloud for analysis and preventive maintenance.



Fluke 1507 Insulation Resistance Tester

Versatile, compact, handheld insulation tester

Insulation tests from 10 kΩ to 2.0 GΩ; live circuit detection to prevent insulation test if voltage >30 V is detected. Provides lo-ohms earth-bond continuity (200 mA).



Models	1587 FC	1587	1577	1503	1507	1550C	1555
Test voltages	50 V to 1000 V	50 V to 1000 V	500 V to 1000 V	500 V to 1000 V	50 V to 1000 V	250 V to 5000 V	250 V to 10,000 V
Insulation resistance range	0.01 MΩ to 2 GΩ	0.01 MΩ to 2 GΩ	0.01 MΩ to 600 GΩ	0.01 MΩ to 2000 GΩ	0.01 MΩ to 10 GΩ	200 k to 1 TΩ	200 k to 2 TΩ
PI/DAR	•	•	•		•	Yes, plus Fluke Connect*	Yes, plus Fluke Connect*
Auto discharge	•	•	•	•	•	•	•
Timed ramp test (breakdown)						•	•
Pass/fail comparison					•	•	•
Memory	Through Fluke Connect					Yes, plus Fluke Connect*	Yes, plus Fluke Connect*
Remote test probe	•	•	•	•	•		
Remote start and setup						Yes, through Fluke Connect*	Yes, through Fluke Connect*
Lo ohms/earth-bond continuity				200 mA source (10 mΩ resolution)	200 mA source (10 mΩ resolution)		
Backlight	•	•	•	•	•		
Multimeter functions	•	•	•				
Warranty (years)	3	3	3	1	1	3	3

*Using Fluke ir3000 FC adapter with Fluke Connect compatible 155x models

POWER QUALITY AND ENERGY ANALYSIS

Whether you're in an industrial plant, large-scale facility or a utility, Fluke power quality and energy analysis tools help you capture the data you need to maintain the best performance and reliability. These tools make it possible to identify your power quality and energy efficiency issues with easy and effective recording and analysis.

Power and energy loggers

Power and energy loggers are used for conducting energy and load studies to discover where savings are possible. With the Fluke Energy Analyze Plus software, it's possible to create detailed reports to focus on the problem spots.

Power quality troubleshooters and analyzers

Three-phase power quality analyzers are ideal for troubleshooting, logging and creating detailed reports in conjunction with the easy-to-use PowerLog software. Fluke single-phase power quality meters can measure and log either ac or dc power systems, depending on the model selected. These single-phase and three-phase solutions will allow you to quickly discover where potential problems in your electrical system are located.

Power quality recorders

Power quality recorders capture the highly detailed data you need to discover the most difficult-to-find problems. When used with the supporting application software, a recorder can help you see the full picture, enabling you to fix the problems.

Precision power analyzers

Whether it's testing the performance of transformers, lighting or switching electronics such as inverters and power supplies, these instruments have the highest accuracy and can handle the most difficult waveforms. For very low power factor or loads with high-frequency switching, Fluke has solutions that can measure on single-, three- or six-phase systems.



FEATURED PRODUCTS



Fluke 435 Series II Energy & Power Analyzer

The Fluke 435-II is designed for users who need to get to the solution of the power quality problem as quickly as possible.

- Create a complete power quality health summary in one screen which quickly highlights problem areas—saving time to get to the causes of the problem
- Calculate the cost of wasted energy, prevent downtime and troubleshoot the source of power quality or motor performance issues



Fluke 438-II Power Quality Analyzer and Motor Analyzer

Quickly and easily discover the electrical and mechanical performance of electric motors, and evaluate power quality with a single test tool.

The Fluke 438-II has all functions of the Fluke 435 Series II Power Quality Analyzer, plus:

- Measure key motor parameters like torque, RPM and mechanical power and efficiency without mechanical sensors
- Measure electrical power parameters that impact motor efficiency, such as voltage, current, power, apparent power, power factor, harmonic distortion and unbalance
- Identify power quality issues such as dips, swells, transients, harmonics and unbalance



Fluke 1748 Three-Phase Power Quality Logger

Troubleshoot, quantify energy usage and perform power quality of surveys easier than ever.

The 1748 Three-Phase Power Quality Logger gives you fast, easy access to the comprehensive data you need to make critical power quality and energy decisions in realtime. With the included Energy Analyze Plus software package you can easily create detailed reports at the touch of a button.

- The auto-configuration check ensures every measurement campaign is right, the first time
- Measure detailed power quality and power parameters—over 500 different parameters are logged for each averaging period
- Create comprehensive reports according to the most common power quality standards in seconds
- Conveniently power the instrument directly from the measured circuit



Fluke 1738 Advanced Power and Energy Logger

Get more visibility, reduce uncertainty and make better power quality and energy consumption decisions.

The Fluke 1738 Three-Phase Advanced Power and Energy Logger built with Fluke Connect™ mobile app and desktop software compatibility is the ideal tool for conducting energy studies and power quality surveys.

- Automatically capture and log voltage, current, power, harmonics and associated power quality values
- Capture dips, swells and inrush currents: includes an event waveform snapshot and a high-resolution RMS profile, to give your electrical system a power quality health check and discover where and when energy is being wasted
- Conveniently power the instrument directly from the measured circuit

POWER QUALITY AND ENERGY ANALYSIS SELECTION GUIDE



	Application use	Single-phase		Three-phase				
		VR1710	345	1732/1734 ¹	1736/1738 ²	1742	1746	1748
Energy studies								
Measure V, I, kW, Cos/DPF, kWhr	Get detailed power and energy consumption profiles during energy audits and pinpoint savings opportunities		•	•	•	•	•	•
Measure min/max and avg values			•	•	•	•	•	•
10-day logging			•	•	•	•	•	•
Waste energy monetization								
Basic harmonics study								
THD measurement (V & I)	Discover the source of distortion in your installation, so that you can filter those loads or move them to separate circuits	•	•	•	•	•	•	•
Harmonics 1 to 25 for V & I		• (V only)	•		•		•	•
Advanced harmonics study								
Full harmonic spectrum	If distorting loads are causing problems in your installation, you need comprehensive data to identify the source and create a solution		•		•		•	•
Power harmonics			•					
Basic industrial PQ troubleshooting								
Oscilloscope function	When troubleshooting in the field, graphical data enables you to trace the source of the problem at hand		•		•			
Voltage dips and swells		•			•	•	•	•
Advanced industrial PQ troubleshooting								
Comprehensive logging capability	Complex installations often require a deeper dive into measurement data. Multiple loads may be interacting randomly to cause a single problem		•		•	•	•	•
Advanced features								
Inrush	Discover peak current from load switching				1738 ²			•
Flicker	Measure the effects of disturbing switching equipment	•				•	•	•
Transients	Capture high-speed voltage waveform caused by switching or network disturbances	•						• ³
Mains signaling	Monitor signals on the network that are used for network wide equipment control						•	•
Power wave	Capture voltage and current waveforms over defined periods to discover the effects of motor and generator startups and close downs							
Event waveform capture	Visualization of dips and swells to identify the cause of the events	•			1738 ²			•
400 Hz	Measurement for avionics and shipboard systems							
Shipboard power	Quantify shipboard power against defined international standards							
Power inverter efficiency	Measure input and output power of inverters to optimize system performance							
Motor analysis								
Speed, torque, mechanical power, efficiency	Perform dynamic motor analysis by plotting of motor de-rating factor against load according to NEMA/IEC guidelines on direct online electric motors and motors driven by specific variable-frequency drive systems							
Communications								
USB		•	•	•	•	•	•	•
Ethernet						•	•	•
Wireless download				1734 ¹	•	•	•	•
Fluke Connect app				1734 ¹	•	•	•	•
Safety								
CAT IV/600 V			•	•	•	•	•	•
CAT II/300 V		•						
Power from measurement line		•		•	•	•	•	•



	Application use	Three-phase continued					
		434-II	435-II	437-II	438-II	1750 ⁴	1760
Energy studies							
Measure V, I, kW, Cos/DPF, kWhr	Get detailed power and energy consumption profiles during energy audits and pinpoint savings opportunities	•	•	•	•	•	•
Measure MIN/MAX and AVG values		•	•	•	•	•	•
10-day logging		•	•	•	•	•	•
Waste energy monetization		•	•	•	•	•	•
Basic harmonics study							
THD measurement (V & I)	Discover the source of distortion in your installation, so that you can filter those loads or move them to separate circuits	•	•	•	•	•	•
Harmonics 1 to 25 for V & I		•	•	•	•	•	•
Advanced harmonics study							
Full harmonic spectrum	If distorting loads are causing problems in your installation, you need comprehensive data to identify the source and create a solution	•	•	•	•	•	•
Power harmonics		•	•	•	•	•	•
Basic industrial PQ troubleshooting							
Oscilloscope function	When troubleshooting in the field, graphical data enables you to trace the source of the problem at hand	•	•	•	•	•	•
Voltage dips and swells		•	•	•	•	•	•
Advanced industrial PQ troubleshooting							
Comprehensive logging capability	Complex installations often require a deeper dive into measurement data. Multiple loads may be interacting randomly to cause a single problem	•	•	•	•	•	•
Advanced features							
Inrush	Discover peak current from load switching	•	•	•	•	•	•
Flicker	Measure the effects of disturbing switching equipment	•	•	•	•	•	•
Transients	Capture high-speed voltage waveform caused by switching or network disturbances		•	•	•	•	•
Mains signaling	Monitor signals on the network that are used for network wide equipment control		•	•	•	•	•
Power wave	Capture voltage and current waveforms over defined periods to discover the effects of motor and generator startups and close downs		•	•	•		
Event waveform capture	Visualization of dips and swells to identify the cause of the events		•	•	•	•	•
400 Hz	Measurement for avionics and shipboard systems			•			
Shipboard power	Quantify shipboard power against defined international standards			•			
Power inverter efficiency	Measure input and output power of inverters to optimize system performance	•	•	•	•		
Motor analysis							
Speed, torque, mechanical power, efficiency	Perform dynamic motor analysis by plotting of motor de-rating factor against load according to NEMA/IEC guidelines on direct online electric motors and motors driven by specific variable-frequency drive systems	Upgrade available	Upgrade available	Upgrade available	•		
Communications							
USB		•	•	•	•		•
Ethernet						•	•
Wireless download		•	•	•	•		
Fluke Connect app		•	•	•	•		
Safety							
CAT IV/600 V		•	•	•	•	•	•
CAT II/300 V							
Power from measurement line							

¹An upgrade package is available to upgrade an existing 1732 Energy Logger with the same features and capabilities of the 1734 Energy Logger.
²An upgrade package is available to upgrade an existing 1736 Power Logger with the same features and capabilities of the 1738 Advanced Power Logger.
³Event waveform capture (10.24 kHz sampling).
⁴Not available in Europe.

BATTERY ANALYZERS

Fluke battery analyzers are the ideal test tool for maintaining, troubleshooting and performance testing the individual stationary batteries and battery banks that are used in critical battery backup applications in data centers, telecom networks, power distribution systems and more. With an intuitive user interface, a compact design and rugged construction, the Fluke battery analyzers provide optimum performance, test results and reliability.

The Fluke 500 Series Battery Analyzers cover a broad range of battery test functions, from ripple voltage to multi-measurement mode, which shortens test times by performing three measurements in one: dc voltage, internal resistance tests and infrared temperature measurement.



FEATURED PRODUCTS



Fluke Battery Analyzers

By reducing testing complexity, simplifying testing workflow and incorporating an intuitive user interface, the Fluke BT510 Basic Battery Analyzer, BT520 Battery Analyzer and BT521 Advanced Battery Analyzer bring a new level of ease of use for testing stationary batteries of all types.

- Key measurements: Internal battery resistance, dc and ac voltage, dc and ac current, ripple voltage, frequency and temperature
- Sequence measurement mode: Automatic or manual sequence testing of battery strings with automatic measurement storage including voltage, resistance and temperature (with BTL21 intelligent test probe), eliminating the need to press a button each time a measurement needs to be saved
- Comprehensive logging: All measured values are automatically captured during testing and can be reviewed on the instrument before downloading for on-the-go analysis
- Optimized user interface: Quick, guided setup and profile creation ensures the right data is captured every time, and the combined visual and audio feedback cues reduce the risk of measurement confusion
- Safety rating: CAT III 600 V



Functions	Range	Resolution	Accuracy	BT510	BT520	BT521
Battery resistance ¹	3 mΩ	0.001 mΩ	1 % + 8	•	•	•
	30 mΩ	0.01 mΩ	0.8 % + 6	•	•	•
	300 mΩ	0.1 mΩ	0.8 % + 6	•	•	•
	3000 mΩ	1 mΩ	0.8 % + 6	•	•	•
V dc	6 V	0.001 V	0.9 % + 5	•	•	•
	60 V	0.01 V	0.9 % + 5	•	•	•
	600 V	0.1 V	0.9 % + 5	•	•	•
	1000 V	1 V	0.9 % + 5	•	•	•
V ac (45 Hz to 500 Hz with 800 Hz filter)	600 V	0.1 V	2 % + 10	•	•	•
Frequency (displayed with V ac and A ac) ²	500 Hz	0.1 Hz	0.5 % + 8	•	•	•
AC voltage ripple (20 KHz max)	600 mV	0.1 mV	3 % + 20	•	•	•
	6000 mV	1 mV	3 % + 10	•	•	•
A dc/A ac (with accessory Fluke i410)	400 A	1 A	3.5 % + 2			•
Temperature	0 °C to 60 °C (32 °F to 140 °F)	1 °C (33.8 °F)	2 °C (4 °F)			•
Interactive Test Probe set, with extender					•	•
Meter mode	999 records for each measurement position with time stamp					
Sequence mode	Up to 100 profiles and 100 profile templates (each profile stores up to 450 batteries) with time stamp					

¹The measurement is based on AC injection method. The injected source signal is 100 mA, 925 Hz.

²Trigger level V ac: 10 mV, A ac: 10 A.

PROCESS CALIBRATION TOOLS

Working in a process environment such as pharmaceutical manufacturing, refining or other industrial areas can be challenging. Process instruments are often installed in harsh operating environments that can cause their performance and the performance of their sensors to shift or change over time. These instruments provide measurements to the process plant's control system, and their performance is critical to the operation and safety of the plant. But, maintaining, building and calibrating process systems takes special expertise.

Whether you're working at a bench, out in the plant or in the field, you need accurate tools that you can count on. Fluke process calibration tools include a full range of calibrators and troubleshooting tools for instrument technicians working in the process industries that will help ensure these measurement devices are operating within their expected limits.

The range of process calibrators include documenting process calibrators, multifunction process calibrators, single-function and multifunction temperature calibrators, pressure calibrators and a variety of mA loop calibrators. As a process calibration leader, Fluke has designed tools that can help you tackle the specific challenges you face every day.



FEATURED mA LOOP CALIBRATORS

Loop calibrators are essential tools for working with 4-20 mA current loops. Fluke loop calibrators provide mA sourcing, simulation and measurement readouts in both mA and % of span along with a 24 V loop supply, simple operation and accuracy you can count on. Our HART-enabled loop calibrators help you get the most out of your smart transmitter calibrations, adding useful configuration capabilities and giving you more access and information on the HART devices you're testing.



Fluke 773 Milliamp Process Clamp Meter

The Fluke 773 mA Process Clamp Meter is accurate and versatile and lets you measure output signals without ever breaking the loop. Ideal for troubleshooting transmitters, valves and programmable logic controllers (PLCs) found in process plants, the 773 lets you troubleshoot a live device without having to power down and possibly miss something going on in the process.

- Measure dc voltage to verify 24 V power supplies or voltage I/O signals
- Source 0-10 and 1-5 vdc voltage signals to test voltage input devices
- Record a 4-20 mA signal without breaking the loop, using the scaled mA output signal and a logging DMM



789 ProcessMeter™

The Fluke 789 ProcessMeter doubles troubleshooting capabilities by combining the power of a safety rated digital multimeter and mA loop calibrator into a single, compact test tool. Whether you only need to source and simulate mA, or need a 24 V loop power supply, the 789 is designed to meet your needs. Add the wireless data-logging capabilities of Fluke Connect™ with ShareLive™ video call, and process technicians can do a lot more while carrying a lot less.

- Combines the functionality of a loop calibrator with the power of a precision 1000 V, True-rms digital multimeter with a CAT IV 600 V rating
- HART mode setting with loop power (adds 250 ohm resistor)
- Simultaneous mA and % of scale readout on 4-20 mA output and measurement



710 mA Loop Valve Tester

The Fluke 710 mA Loop Valve Tester is a compact and powerful HART communication tool that saves time and produces high-quality results. Not only does the 710 perform all of the loop calibration functions of the 709H Precision HART loop calibrator, this tool also reduces the time it takes to measure or source current and power up a loop while enabling quick, easy tests on HART smart control valves.

- Key valve-testing functions include preconfigured valve signature test, speed test, step test, manual test and bump/partial stroke test
- Key mA loop calibrator functions include mA source, mA simulate, mA read, mA read/loop power and volts read
- HART communication for testing and light configuration of HART transmitters
- Upload valve test results, logged measurements and HART device configurations captured in the field with included ValveTrack™ desktop software

FEATURED MULTIFUNCTION CALIBRATORS

Fluke multifunction calibration tools are designed to calibrate almost anything. These calibration tools source and measure almost all process parameters and documenting versions even document the results.



753 Documenting Process Calibrator

The Fluke 753 is a powerful multifunction documenting calibrator that lets you download procedures, lists and instructions created with software, and upload data for printing, archiving and analysis. It sources, simulates, and measures pressure, temperature and electrical signals in one rugged, hand-held calibration tool. It also automates calibration procedures, captures data for documentation and helps you meet rigorous standards like ISO 9000, FDA, EPA, and OSHA regulations.

- Measures volts, mA, RTDs, thermocouples, frequency and ohms to test sensors, transmitters and other instruments
- Sources and simulate volts, mA, pressure, thermocouples, RTDs, frequency, ohms and pressure to calibrate transmitters
- Powers transmitters during test using loop supply with simultaneous mA measurement
- Manage calibration procedures, upload and print results and schedule calibrations with optional DPCTrack2 Calibration Management software



754 HART Enabled Documenting Process Calibrator

Whether you're calibrating instruments, troubleshooting a problem, or running routine maintenance, the Fluke 754 with HART[®] communication can help you get the job done faster. It does so many different tasks, so quickly and so well, it's the only process calibrator you need to carry. This rugged, reliable integrated communicating calibrator does everything the Fluke 753 does and is ideal for calibrating, maintaining, and troubleshooting HART and other instrumentation.

- Full-featured documenting process calibrator with HART communication for calibrating and troubleshooting HART instrumentation
- Measures volts, mA, TDs, thermocouples, frequency and ohms to test sensors, transmitters and more
- Sources/simulates volts, mA, thermocouples, RTDs, frequency, ohms and pressure to calibrate transmitters
- Powers transmitters during test using loop supply with simultaneous mA measurement



726 Precision Multifunction Process Calibrator

The Fluke 726 is a precise and powerful, yet easy-to-use field calibrator. It features broad workload coverage, calibration power and unsurpassed accuracy needed by process professionals. It measures and sources almost all process parameters to calibrate almost anything. Use it to test sensors and valves and test and calibrate transmitters.

- Delivers precise measurement and calibration source performance with accuracies of 0.01 %.
- Stores up to eight calibration results in memory for later analysis
- Offers HART mode that inserts a 250 ohm resistor in mA measure and source for compatibility with HART instrumentation

FEATURED TEMPERATURE CALIBRATORS

Fluke Temperature Calibrators simulate process sensors for testing temperature instrumentation. Specifically designed for the field, these lightweight compact tools are EMI tolerant, dust and splash resistant and offer an easy to use single push button interface. When paired with a temperature sensor they can take high accuracy temperature measurements to verify process temperatures and ensure the highest product quality and safety.



Fluke 724 Temperature Calibrator

The Fluke 724 is powerful yet easy-to-use temperature calibrator that sources and measures 10 thermocouple types and 7 RTD types, plus volts and ohms. It also measures mA while supplying loop power. You can use it to test and calibrate almost any temperature instrument so you only have to carry one tool to expertly test all the temperature sensors and transmitters in your plant.

- Displays input and output simultaneously on the easy-to-read dual display
- Measures RTDs, thermocouples, ohms, and volts to test sensors and transmitters
- Sources/simulates thermocouples, RTDs, volts, and ohms to calibrate transmitters



Fluke 712B RTD Calibrator

The Fluke 712B is a handheld, battery-operated calibrator that measures and sources a variety of RTD types and resistances. It also includes an isolated channel to measure 4-20 mA while sourcing a temperature signal. It offers configurable 0 % and 100 % source settings for quick 25 % linearity checks. It also provides linear ramp and 25 % step auto ramp functionality based on 0 % and 100 % settings.

- Highly accurate, full-featured, easy-to-use single function RTD temperature calibrator
- Measures and simulates 14 different RTD types and resistance
- Measures 4 to 20 mA signals while simultaneously sourcing a temperature signal



Fluke 714B Thermocouple Calibrator

The Fluke 714B is a handheld, battery-operated calibrator that measures and sources a variety of thermocouple types and millivolts. Calibrates a linear thermocouple transmitter with the mV source function and measures mA while sourcing temperature. It also provides linear ramp and 25 % step auto ramp functionality based on 0 % and 100 % settings.

- Highly accurate, full featured easy-to-use, single-function thermocouple temperature calibrator
- Measures and simulates 17 thermocouple types and millivolts
- Measures 4 to 20 mA signals while simultaneously sourcing a temperature signal

FEATURED PRESSURE CALIBRATORS

Pressure instrumentation is found in virtually every process plant. Periodic calibration of these instruments is required to keep plants operating efficiently and safely. Fluke offers a wide range of pressure calibration tools with precision pressure measurement from 0-1 inH₂O/2.5 mbar to 10,000 psi/690 bar boasting 0.025 % full-scale accuracy to help you quickly and reliably calibrate your pressure instruments.

Everything from simple test gauges to calibrators with built-in, automatic, electric test pumps. Easy-to-use, rugged and reliable construction and an industry best three-year warranty.



Fluke 729 Automatic Pressure Calibrator

The Fluke 729 Automatic Pressure Calibrator was designed specifically with process technicians in mind to simplify the pressure calibration process and provide faster, more accurate test results. Technicians know that calibrating pressure can be a time-consuming task, but the 729 makes it easier than ever with an internal electric pump that provides automatic pressure generation and regulation in an easy-to-use, rugged, portable package.

- Automatic pressure generation and regulation to 300 psi
- Easily document the process using onboard test templates
- Automatic internal fine-pressure adjustment
- Measure, source and simulate 4 to 20 mA signals
- Compatible with DPCTrack2 calibration management software



Fluke 719Pro Electric Pressure Calibrator

The 719Pro includes a full-functioning loop calibrator that sources, simulates and measures mA signals and more, making it the ideal test tool for calibrating high-accuracy transmitters, pressure switches and pressure gauges. Get the ultimate in measurement flexibility with the large backlit screen, which displays three parameters at once: pressure measurement from internal or external sensor, sourced/simulated or measured mA values and temperature measured by optional RTD probe.

- Unique, integrated electric pump for one-handed pressure calibration up to 300 psi
- Test pressure switches easily with the easy-to-use switch test function
- Precision pressure adjust vernier for easy and accurate pressure calibration



Fluke 700G Precision Pressure Test Gauges

With best-in-class accuracy and measurements, the Fluke 700G Precision Pressure Test Gauges handle all of your pressure calibration needs. The 700G Series Gauges are rugged and easy to use, with 23 models ranging from ± 10 inH₂O/25 mbar to 10,000 psi/690 bar, including absolute pressure ranges. When you combine the 700G Series Gauges with the Fluke 700PTPK or 700HTPK, you've got a complete pressure-testing solution for up to 600 psi (40 bar) with the PTP-1 pneumatic pump and up to 10,000 psi (690 bar) with the HTP-2 hydraulic pump.

- Rugged, high-quality pressure gauge calibrator for fast and accurate test results
- Delivers precision pressure measurements in 23 ranges from ± 10 inH₂O/20 mbar to 10,000 psi/690 bar
- Delivers high accuracy—0.05 % total measurement uncertainty for one year
- Log pressure measurement in the field and upload with optional 700GTrack software

PROCESS CALIBRATION TOOLS SELECTION GUIDE



Models	mA Loop calibrators				
	Loop calibrators provide a range of options for instrument technicians commissioning, calibrating or assessing the health of 4-20 mA control circuits in a compact and easy-to-use tool.				
	715	707EX	709	709H	710
Specifications					
mA measure (range and accuracy)	0-24 mA @ 0.01 %	0-24 mA @ 0.015 %	0-24 mA @ 0.01%	0-24 mA @ 0.01 %	0-24 mA @ 0.01 %
mA source/simulate	0-24 mA @ 0.01 %	0-24 mA @ 0.015 %	0-24 mA @ 0.01%	0-24 mA @ 0.01 %	0-24 mA @ 0.01%
DCV measure	0-25V @ .01 %	0-28 V @ .015 %	0-30 V @ .01 %	0-30 V @ .01 %	0-30 V @ .01 %
DCV source	0-25V @ .01 %				
ACV measure					
Features					
24 V loop power	•	•	•	•	•
Auto step/ramp	•	•	•	•	•
Documenting and log data				Option	•
HART communication				•	•
Intrinsically safe		•			
Valve testing	Analog	Analog	Analog	Analog	Analog/HART
Non-contact clamp					
Fluke Connect					



Models	Process calibrators			
	Process meters are advanced digital multimeters designed for commissioning, verifying or troubleshooting 4-20 mA control loops in process applications.			
	787B	789	771	773
Specifications				
mA measure (range and accuracy)	0-30 mA @ 0.05 %	0-30 mA @ 0.05 %	0-20.99 mA @ 0.2 % , 21.0-99.9 mA 1 %	0-20.99 mA @ 0.2 % , 21.0-99.9 mA 1 %
mA source/simulate	0-24 mA @ 0.05 %	0-24 mA @ 0.05 %		0-24 mA @ 0.2 %
DCV measure	CAT IV 600 V/CAT III 1000 V	CAT IV 600 V/CAT III 1000 V		0-30 V @ .2 %
DCV source				0-10 V @ .01 %
ACV measure	CAT IV 600 V/CAT III 1000 V	CAT IV 600 V/CAT III 1000 V		
Features				
24 V loop power		•		•
Auto step/ramp	•	•		•
Documenting and log data				
HART communication				
Intrinsically safe				
Valve testing	Analog	Analog		Analog
Non-contact clamp			•	•
Fluke Connect	Option	Option		

PROCESS CALIBRATION TOOLS SELECTION GUIDE



Models	Multifunction calibrators					Communicators
	725	725EX*	726	753	754	154
Specifications						
mA measure (range and accuracy)	0-24 mA @ 0.02 %	0-24 mA @ 0.02 %	0-24 mA @ 0.01%	0-100mA @ 0.01%	0-100mA @ 0.01%	
mA source/simulate	0-24 mA @ 0.02 %	0-24 mA @ 0.02 %	0-24 mA @ 0.01%	0-22 mA @ 0.01 %	0-22 mA @ 0.01 %	
DCV measure	0-30 V @ 0.02 %	0-30 V @ 0.02 %	0-30 V @ 0.01 %	0-300 V @ 0.02 %	0-300 V @ 0.02 %	
DCV source	0-10 V @ 0.02 %	0-10 V @ 0.02 %	0-20 V @ 0.01 %	0-15 V @ 0.01 %	0-15 V @ 0.01 %	
ACV measure				0-300 V @ 0.5 %	0-300 V @ 0.5 %	
Ohms measure	0-3.2 K Ω	0-3.2 K Ω	0-4 K Ω	0-10 K Ω	0-10 K Ω	
Ohms source	0-3.2 K Ω	0-3.2 K Ω	0-4 K Ω	0-10 K Ω	0-10 K Ω	
Frequency measure	1-10 kHz	1-10 kHz	1-15 kHz	1-50 kHz	1-50 kHz	
Frequency source	1-10 kHz	1-10 kHz	1-15 kHz	1-50 kHz	1-50 kHz	
750P Pressure Module compatibility	50 models	8 EX models	50 models	50 models	50 models	
Temperature measure/ source	12 TC types, 7 RTD types	12 TC types, 7 RTD types	13 TC types, 8 RTD types	13 TC types, 8 RTD types	13 TC types, 8 RTD types	
Features						
24 V loop power	•	12 V	•	•	•	
Documenting				•	•	
Serial remote operation	•	•	•			
Source auto step/ramp	•	•	•	•	•	
Switch test	•	•	•	•	•	
Fluke Connect™						
HART communication					•	Full DD library
Software				DPCTrack2 (Option)	DPCTrack2 (Option)	FlukeHART Ap
Intrinsically safe		•				

* Not available in all countries

PROCESS CALIBRATION TOOLS SELECTION GUIDE



Models	Pressure calibrators						Temperature calibrators		
	Pressure calibrators ensure proper function of devices, instrumentation and assets in applications where maintaining pressure is critical to the process itself or the control of a process.						Calibration tools used in conjunction with a temperature source (E.g. Drywell) to verify and adjust temperature sensors.		
	700G	718EX	719Pro	721	721EX	729	724	714B	712B
Specifications									
mA measure (range and accuracy)		0-24 mA @ 0.02 %	0-24 mA @ 0.015 %	0-24 mA @ 0.015 %	0-24 mA @ 0.015 %	0-24 mA @ 0.01 %	0-24 mA @ 0.02 %	0-24 mA @ 0.01 %	0-24 mA @ 0.01 %
mA source/simulate			0-24 mA @ 0.015 %			0-24 mA @ 0.01 %			
DCV measure			0-30 V @ 0.015 %	0-30 V @ 0.015 %		0-30 V @ 0.01 %	0-30 V @ 0.02 %		
DCV source							0-10 V @ 0.02 %		
Model pressure ranges	23 types 10 in H2O to 10,000 psi	0-30 psi 0-100 psi 0-300 psi	0-30 psi 0-100 psi 0-300 psi	14 dual sensor ranges	14 dual sensor ranges	0-30 psi 0-100 psi 0-300 psi			
750P Pressure Module compatibility		8 EX models	50 models	50 models	8 EX models	50 models			
Temperature measure/source			PT100 measure only	PT100 measure only	PT100 measure only	PT100 measure only	12 TC types 7 RTD types	17 TC types	14 RTD types
Features									
24 V loop power			•	•		•	•		
Integral pressure source		Manual	Electric			Electric			
Automatic pressure generation and leak compensation						•			
Documenting						•			
Serial remote operation			•	•		•			
Source auto step/ramp						•	•		
Switch test		•	•	•	•	•			
Fluke Connect™						•			
HART communication						•			
Software	700GTrack					DPCTrack2 (Option)			
Intrinsically safe	•	•			•				

INTRINSICALLY SAFE PRODUCTS

Fluke products designed to intrinsic safety standards

A protection method employed in potentially explosive atmospheres, intrinsically safe devices are designed to be unable to release sufficient energy, by either thermal or electrical means, to cause ignition of flammable material (gas or dust/particulates).

Fluke products	ATEX certified	North American Certification
 28 II Ex Intrinsic Safe True-rms Multimeter	 II 2G Ex ia IIC T4 Gb I M1 Ex ia I Ma	 Class I, Div 1, Groups A,B,C,D T4 Class I, Zone 1, AEx ia IIC T4 Ex ia IIC T4 IP67
 707Ex Intrinsic Safe mA Calibrator	 II 2G Ex ia IIC T4	 N.I. Class I, Div 2, Groups A,B,C,D APPROVED
 718Ex Intrinsic Safe Pressure Calibrator	 II 1G Ex ia IIC T4	 I.S. Class I, Div 1, Groups A,B,C,D T4
 721Ex Intrinsic Safe Precision Pressure Calibrator	 II 2G Ex ia IIB T3 Gb	IECEX: Ex ia IIB T3 Gb
 725Ex* Intrinsic Safe Multifunction Calibrator		 I.S. Class I, Div 1, Groups B,C,D, 171 °C
 750PEX Intrinsic Safe Pressure Modules	 II 1G Ex ia IIC T4 Ga	IECEX: Ex ia IIC T4 Ga
 568Ex Intrinsic Safe Infrared Thermometer	 II 2G Ex ia IIC T4 Gb	 Class I, Div 1, Groups A,B,C,D, T4 Class I, Div 2, Groups A,B,C,D, T4 Class I, Zone 1, AEx ia IIC T4 Gb
 700G Series Intrinsic Safe Pressure Gauges	 II 3G Ex ic IIB T6 Gc	 CSA Class I, Div. 2 Groups A,B,C,D
 1551A Ex/1552A Ex Intrinsic Safe "Stik" Thermometers	 II 2G Ex ib IIB T4 Gb	
 Fluke FL-45 Ex Intrinsic Safe Flashlight	 II 1G Ex ia IIC T5 Ga I M1 Ex ia I Ma	 Class I Div 1 and 2 Group A,B,C,D Class II Div 1 and 2 Group E,F,G Class III T5 IP67
 Fluke FL-120 Ex Intrinsic Safe Flashlight	 II 1G Ex ia IIC T4 Ga I M1 Ex ia I Ma	 Class I Div 1 and 2 Group A,B,C,D Class II Div 1 and 2 Group E,F,G Class III T4 IP6X
 Fluke FL-150 Ex Intrinsic Safe Flashlight	 II 1G Ex ia IIC T4 Ga I M1 Ex ia I Ma	 Class I Div 1 and 2 Group A,B,C,D Class II Div 1 and 2 Group E,F,G Class III T4 IP67
 Fluke HL-200 Ex Intrinsic Safe Headlamp	 II 1G Ex ia IIC T4 Ga	 Class I Div 1 and 2 Group A,B,C,D Class II Div 1 and 2 Group E,F,G Class III T4 IP67

* Not available in all countries

There are no global intrinsically safe standards or certifications, but there are organizations that influence directives in certain world geographies.

Factory Mutual



APPROVED

In the United States, Factory Mutual Research, managed by Factory Mutual (FM) Global, is a nonprofit scientific and testing organization that has tested and certified over 40,000 products in the last 165 years. FM Research has set certification guidelines for equipment used in potentially explosive atmospheres.

Canadian Standards Association (CSA)



Accreditation body for North American regulations, based in Toronto, Canada.

ATEX



This symbol signifies compliance to the European directive 2014/34/EU, which governs requirements for equipment intended for use in potentially explosive atmospheres.

ETL



Edison Testing Laboratories (ETL) is an accreditation body for North American regulations such as NEC-500/NEC-505.

UL



Underwriters Laboratories (UL) is a global safety certification company headquartered in the U.S. UL's Marks for Classification service appear on representative samples of products that UL has evaluated with respect to specific properties, a limited range of hazards or suitability for use under limited or special conditions.

PORTABLE OSCILLOSCOPES

ScopeMeter™ portable oscilloscopes take you into territory that standard bench oscilloscopes can't readily withstand—harsh, hazardous and dirty industrial environments. These hand-held instruments combine the performance of a bench oscilloscope with a multimeter and paperless recorder for installing, commissioning and maintaining industrial and electronic equipment out in the field. Each series of tools has unique features—such as Connect-and-View™ mode, IntellaSet™ technology and guided, step-by-step motor-drive test setups—that simplify complex troubleshooting.

Connect-and-View™ triggering

The Connect-and-View triggering functionality of the 190, 120B and MDA-500 Series works with virtually any signal and automatically sets up the oscilloscope. You don't need to adjust parameters or even touch a button.

IntellaSet™/Auto Reading technology

The Auto Readings function with Fluke IntellaSet™ technology of the 120B Series uses proprietary algorithms to analyze the measured waveform and automatically display the most appropriate numerical measurements on-screen, so you can get the data you need easier than ever before.

Guided motor-drive test setups

The preset measurement profiles of the MDA-500 Series allow you to conduct guided measurements for motor-drive input, dc bus, drive output, motor input and shaft measurements with graphical, step-by-step voltage and current connection diagrams.



FEATURED PRODUCTS



Fluke 190 Series II ScopeMeter™ Test Tools

High-performance scopes built for harsh industrial environments

The Fluke 190 Series II ScopeMeter combines the highest safety ratings and rugged portability with the high performance of a bench oscilloscope. Designed for plant maintenance engineers and technicians, these tough ScopeMeter test tools go into harsh, dirty and hazardous industrial conditions to test everything from microelectronics to power electronics applications, with 60, 100, 200 and 500 MHz bandwidth models available.

- Automatically capture and replay the last 100 screens as a “live” animation so you can easily find and evaluate anomalies
- Use the integrated ScopeRecord mode for high-resolution waveform recording of events like motion profiles, UPS, power supply and motor start-ups for up to 48 hours
- Find intermittent faults with TrendPlot™ Paperless Recorder technology so you can pinpoint exactly when a fault occurred



Fluke MDA-500 Series Motor Drive Analyzers

Simplify complex motor-drive troubleshooting

The Fluke MDA-510 and MDA-550 Motor Drive Analyzers simplify the troubleshooting process for variable frequency drives. Step-by-step guided measurements show you where to make voltage and current connections, while preset measurement profiles ensure you will capture all the data you need for each critical motor-drive section—from the input to the output, the dc bus and the motor itself.

- Measure key motor-drive parameters and perform extended harmonics measurements
- Quickly and easily creates reports that are perfect for documenting troubleshooting and collaborative work with others
- Capture additional parameters with full 500 MHz oscilloscope, meter and recording capability



Fluke 120B Series Industrial ScopeMeter™ Test Tools

Three-in-one simplicity for frontline electromechanical troubleshooting

The compact 120B Series ScopeMeter is the rugged oscilloscope solution for industrial electrical and electro-mechanical equipment troubleshooting and maintenance applications. It's a truly integrated test tool, with oscilloscope, multimeter and high-speed recording capabilities.

- Measure voltage, current and power waveforms with numerical values including harmonics, resistance, diode, continuity and capacitance measurements
- Fluke Connect-and-View™ triggering automatically displays waveforms without having to adjust amplitude, timebase and trigger settings
- IntelliSet™ technology analyzes the signal and automatically displays critical numerical readings



ScopeMeter™ SELECTION GUIDE



Models	120B Series			190 Series II							MDA-500 Series	
	123B	124B	125B	190-062	190-102	190-202	190-104	190-204	190-502	190-504	MDA-510	MDA-550
Bandwidth	20 MHz	40 MHz	40 MHz	60 MHz	100 MHz	200 MHz	100 MHz	200 MHz	500 MHz	500 MHz	500 MHz	500 MHz
Input channels												
2 scope/DMM channels	•	•	•									
2 scope channels + 1 DMM				•	•	•			•			
4 channels							•	•		•	•	•
Isolated inputs				•	•	•	•	•	•	•	•	•
Triggering												
Connect-and-View™	•	•	•	•	•	•	•	•	•	•	•	•
IntellaSet™ Technology	•	•	•									
Advanced triggering				•	•	•	•	•	•	•	•	•
Advanced measurement function												
Cursors		•	•	•	•	•	•	•	•	•	•	•
TrendPlot™	•	•	•	•	•	•	•	•	•	•	•	•
ScopeRecord™	•	•	•	•	•	•	•	•	•	•	•	•
100 screen replay				•	•	•	•	•	•	•	•	•
Industrial Bus Health			•									
Harmonics			•									•
FFT				•	•	•	•	•	•	•	•	•
Power measurements			•	•	•	•	•	•	•	•	•	•
Waveform mathematics			•	•	•	•	•	•	•	•	•	•
Guided motor-drive analysis												
Motor drive input (V, I, Unbalance)											•	•
Motor drive input harmonics (2-150)												•
Motor drive dc bus											•	•
Motor drive output PWM (V, I, dV/dt, overshoot)											•	•
Motor drive input PWM (V, I, dV/dt, overshoot)											•	•
Motor shaft voltage discharges												•
EN61010-1 safety												
CAT III 1000 V				•	•	•	•	•	•	•	•	•
CAT IV 600 V	•	•	•	•	•	•	•	•	•	•	•	•
Interface												
Optical RS-232	•	•	•									
USB PC interface	Optional	Optional	Optional	•	•	•	•	•	•	•	•	•
Optional WiFi adapter	•	•	•									
USB memory port				•	•	•	•	•	•	•	•	•
SD memory card	•	•	•									
Power												
Li-ion	•	•	•	•	•	•	•	•	•	•	•	•
Battery (hours)	7	7	7	4 (opt 8)	4 (opt 8)	4 (opt 8)	7	7	7	7	7	7
General specifications												
Size (H x W x D)	259 mm x 132 mm x 55 mm (10.2 in x 5.2 in x 2.15 in)			270 mm x 190 mm x 70 mm (10.5 in x 7.5 in x 2.8 in)								
Weight	1.4 kg (3.2 lb)			2.2 kg (4.8 lb)								
Fluke Connect™												
Fluke Connect app	•	•	•									

INDUSTRIAL IMAGING



When you're conducting industrial imaging inspections, high-quality images that allow for better analysis, presentation and professionalism are essential. Fluke Industrial Imaging tools are designed for everyday use, in the toughest industrial environments, for thorough and accurate inspections. Whether you're on the factory floor inspecting conveyor belts and compressors, inspecting outdoor substations or conducting an energy audit in a commercial building, you need to quickly identify potential problems, prevent unplanned downtime and eliminate potential safety hazards.

Sonic imaging

Sonic imaging enables maintenance teams to quickly and accurately locate pressurized air, steam, gas and vacuum leaks. This new technology allows technicians to isolate the sound frequency, so they can filter out background noise and inspect entire plants even in noisy environments.

SoundSight™ technology quickly pinpoints the location of leaks. A SoundMap™ image is applied to a visible light image to quickly provide a fast visual context of the location. Reduce the time spent in detecting leaks, maximize your compressor usage and inspect entire plants, even during peak production periods.

High resolution Diagnostic Videoscopes

Industrial inspections require a powerful diagnostic videoscope designed to stand up to the dirtiest, most harsh environments. Fluke diagnostic videoscopes put high-resolution images in the palm of your hand.

Thermal imaging

Thermal cameras offer premium image quality with superbly engineered resolution and thermal sensitivity. Our lineup offers streamlined solutions for optimal resolution, efficiency and results.

FEATURED INDUSTRIAL IMAGING PRODUCTS



Fluke ii900 Sonic Industrial Imager

Quickly pinpoint the location of leaks

Using SoundSight™ technology, the Fluke ii900 Sonic Industrial Imager, quickly finds compressed leaks in air, steam, gas and vacuum systems, that effect both production uptime and the operations bottom line.

The 7" LCD touchscreen overlays a SoundMap™ image for quick leak identification. With minimal training, maintenance technicians can check for leaks during their typical routine—even during peak operation hours.

The ii900 Sonic Industrial Imager lets technicians see sound as they scan hoses, fittings, and connections for leaks. Its built-in acoustic array of tiny sensitive microphones generates a spectrum of decibel levels per frequency. Based on this output, an algorithm calculates a sound image, known as SoundMap™ that is superimposed on a visual image. The SoundMap is automatically adapted depending on the frequency level selected so that background noise is filtered out.

Key Benefits:

- Fast, simple leak location identification
- Optimize air compressors—delay the capital expense of installing additional compressors
- Ensure proper pressure to pneumatic equipment
- Lower energy and gas costs
- Improve reliability to the production line
- Make leak detection part of typical maintenance routine
- Validate repairs on the spot



Fluke DS701 and DS703 FC High Resolution Diagnostic Videoscopes

Fluke Diagnostic Videoscopes put high-resolution images in the palm of your hand.

- High definition probe with dual-view camera
- Processing speeds that render a smooth, clear, consistent image
- 7" LCD screen for accurate diagnostics in difficult to reach spaces
- Macro to micro zoom function
- Adjustable LED lighting and digital zoom for quality images

Fluke DS701 Diagnostic Videoscope

Rugged, industrial 800 x 600 resolution diagnostic videoscope with dual view probe. Up is Up® technology rotates the display screen to allow for appropriate image display, regardless of the orientation of the probe (8.5 millimeter, 1.2 meter probe only). Intuitive user interface with easy to navigate button technology.

Fluke DS703 FC High Resolution Diagnostic Videoscope with Fluke Connect™

Rugged, high-definition industrial 1280 x 720 resolution diagnostic videoscope with Wi-Fi capability. 720p video recording inspection camera. Up is Up® technology rotates the display screen to allow for appropriate image display, regardless of the orientation of the probe (8.5 millimeter, 1.2 meter probe only).

Save time: Wirelessly sync images directly from your videoscope to the Fluke Connect™ system, and attach to an asset record or work order. Having access to maintenance records simultaneously at the inspection site and from the office or an off-site location enables faster decision making and real-time collaboration between team members. You can also live stream images or videos from your scope to a smartphone or PC.



FEATURED THERMOGRAPHY PRODUCTS



Fluke Ti401 PRO Thermal Imager

Crisp images with 640 x 480 resolution

Fluke Ti401 PRO offers the ruggedness and ease of use that you expect from Fluke. Get sharp, crisp images with 640 x 480 resolution. The portable and easy to use pistol-grip design allows for one-handed use. Never lose sight of an issue with the 3.5-inch (landscape) LCD touch screen. Use infrared data and operate the camera remotely with Fluke Connect Desktop software.



Fluke Ti480 PRO Thermal Imager

Sharp images with 640 x 480 resolution and enhanced features

The Ti480 PRO is a best-in-class hand-held infrared camera that offers 640 x 480 resolution. Get the right level of detail for electrical, mechanical and environmental inspections. Image enhancement features with MultiSharp™ for focused images near and far throughout the field of view and LaserSharp™ Auto Focus for consistently in-focus images. Stream infrared data and operate the camera remotely with Fluke Connect™ system software.



Fluke TiX501 Thermal Imager

Articulating camera at 640 x 480 resolution

Equipped with Fluke 640 x 480 resolution, the TiX501 offers 240-degree articulation for working in hard-to-reach places. Ergonomic design gives you the flexibility to hold the camera in a position that is comfortable, even when taking images overhead and around hard to reach targets. Take advantage of analytics and reports with software that offers streaming infrared data, trend analysis and remote camera operation.



Fluke TiX580 Thermal Imager

Ergonomic camera with 640 x 480 resolution with enhanced features

The Fluke TiX580 offers 640 x 480 resolution and 240-degree articulation, to capture needed data and information in hard-to-reach places. Experience premium resolution, portability and ease of use. Fluke image enhancement features such as MultiSharp™ for focused images near and far throughout the field of view and LaserSharp™ Auto Focus for consistently in-focus images. Monitor processes with video recording, live video streaming, remote control, or auto capture. Find subtle temperature differences easily—with advanced thermal sensitivity.

FEATURED THERMOGRAPHY PRODUCTS

Fluke PTi120 Pocket Thermal Imager

The power of a professional-grade thermal imager that fits in your pocket

Rugged, portable thermal camera for industrial inspection

Small enough to carry every day without worry. Always on hand. Stands up to dirt and water. Now enhanced infrared inspections are right in your pocket for quick temperature scans of electrical equipment, machinery and other assets.

- Automatically organizes and files thermal images with Fluke Connect Asset Tagging
- A fully radiometric thermal imager
- 120 x 90 infrared resolution (10,800 pixels)
- 3.5" LCD touchscreen display for easy troubleshooting
- Can withstand a drop of up to 1 meter
- IP54 enclosure rating
- -20 °C to 150 °C temperature measurement range
- Touchscreen IR-Fusion blends a visible light image with an infrared image



FEATURED IR WINDOWS



Fluke IR Windows CV400/401/300/301/200/201 CLKT100/50

Increase the safety and speed of your electrical infrared inspections

A company's greatest investment is not the equipment that's behind the panel door. It's the electricians, engineers and inspectors who risk their lives every day doing their jobs.

- Highest arc blast safety rating available—63 kA*
- Under 5 minute installation with 1 person; no need to remove panel door
- Clearly view equipment both visually and thermally with ClirVu® coating that protects the optic from the elements
- Corrosion and UV resistant for challenging outdoor environments—IP67 rugged*

*CV series only



Models	CV400	CV401	CV300	CV301	CV200	CV201	FLK-100-CLKT	FLK-050-CLKT
Description	4 in (95 mm) IR Windows, Hand Turn Door Latch	4 in (95 mm) IR Windows, Security Key Door Latch	3 in (75 mm) IR Windows, Hand Turn Door Latch	3 in (75 mm) IR Windows, Security Key Door Latch	2 in (50 mm) IR Windows, Hand Turn Door Latch	2 in (50 mm) IR Windows, Security Key Door Latch	4 in (100 mm) C-Range IR Windows, Kwik Twist	2 in (50 mm) C-Range IR Windows, Kwik Twist
Included accessories	Fluke IR Windows are supplied complete, assembled and ready for installation. In addition to the IR Windows, each carton contains warranty statement and security key if that option is ordered.						Fluke IR Windows are supplied complete, assembled and ready for installation. In addition to the IR Windows, each carton contains warranty statement.	

ACOUSTIC IMAGING SELECTION GUIDE



Model	ii900	
Sensors		Definition
# of microphones	64 digital MEMS microphones	Micro-Electro-Mechanical Systems, or MEMS refers to miniaturized mechanical and electro-mechanical elements
Frequency band	2 kHz to 52 kHz	
Sound pressure sensitivity	Detects a 0.005 CFM leak at 100 PSI from up to 33 feet* (Detects a 2.5 cm ³ /sec leak at 7 bar from up to 10 meters)	
Operation distance range	0.5 to > 50 meters (1.6 to > 164 feet)*	
Field of view	63°± 5°	
Minimum frame rate	12.5 FPS	The number of Frames Per Second (FPS) indicates the number of times the images on the screen is refreshed each second
Built-in digital camera (visible light)		
Field of view (FOV)	63°± 5°	
Focus	Fixed lens	
Display 7" LCD with backlight, under-sunlight readable		
Resolution	1280 x 800 (1,024,000 pixels)	
Touchscreen	Capacitive	Extremely precise and quick responding
Acoustic image	Yes, SoundMap™ image	SoundMap™ is a visual map of noise sources using an acoustical array
Image storage		
Storage capacity	Internal memory with the capacity for 999 picture files and 20 video files	
Image format	Blended visual and SoundMap™.JPG or .PNG	
Video format	Blended visual and SoundMap™.MP4	
Video length	30 seconds	
Digital export	USB-C for data transfer	
Acoustic measurements		
Measurement range	29.3 dB to 119.6 dB SPL (±2 dB) at 2 kHz 21.9 dB to 112.2 dB SPL (±2 dB) at 19 kHz 36.6 dB to 126.9 dB SPL (±2 dB) at 52 kHz	Sound pressure level (dB SPL) or acoustic pressure is the local pressure deviation from the ambient-decible and sound pressure level
Auto max/min dB gain	Auto or manual, user selectable	
Frequency band selection	User selectable through user-made presets or manual entry	
Software		
Ease of use	Intuitive user interface	
Trend graphs	Frequency and dB scale	
Spot markers	dB level reading at center point of the image	
Battery		
Batteries (field-replaceable, rechargeable)	Rechargeable Li-ion, Fluke BP291	
Battery life	6 hours (product includes spare battery)	
Battery charging time	3 hours	
Battery charging system	External dual-bay charger, EDBC 290	
General specifications		
Standard palettes	3: Grayscale, Ironbow and Blue-Red	
Operating temperature	0 °C to 40 °C (32 °F to 104 °F)	
Storage temperature	-20 °C to 70 °C (-4 °F to 158 °F)	
Relative humidity	10 % to 95 % non-condensing	
Size (H x W x L)	186 mm x 322 mm x 68 mm (7.3 inches x 12.7 inches x 2.7 inches)	
Weight (battery included)	1.7 kg (3.75 pounds)	
Main unit rating	IP40 protection against particles 1mm or greater and dripping water	
Sensor head rating	IP51	
Warranty	2 year	
Self-diagnostic notification	Array-health test to identify when microphone array needs attention	
Supported languages	Dutch, English, Finnish, French, German, Italian, Japanese, Korean, Polish, Portuguese, Russian, Simplified Chinese, Spanish, Swedish, Traditional Chinese	
RoHS compliant	Yes	
Safety		
General safety	IEC 61010-1	
Electromagnetic Compatibility (EMC) International	IEC 61326-1: Portable Electromagnetic Environment IEC 61326-2-2 CISPR 11: Group 1, Class A	
Korea (KCC)	Class A Equipment (Industrial Broadcasting and Communication Equipment)	
USA (FCC)	47 CFR 15 subpart B. This product is considered an exempt device per clause 15.103	

*Depending on ambient conditions

DIAGNOSTIC VIDEOSCOPIES SELECTION GUIDE



Model	DS701	DS703 FC
Videoscope probe		
Length	1.2 meter (3.94 feet)	
Type	Detachable, semi-rigid, waterproof, immersible to 1 meter or more in depth	
Diameter	8.5 mm (0.33 inches), optional 3.8, 5.5 and 9 mm probes available	
Material	Elastomer coated steel	
Lighting	Adjustable LED, one front, one side	
Illumination	53 Lux	
UpisUp™ technology	Appropriate image display, regardless of the orientation of the probe, 8.5 MM, 1.2 M probe only	
Camera	Dual view camera, forward and side	
Resolution	800 x 600 (480,000 pixels)	1200 x 720 (864,000 pixels)
Still image format	JPG	
Video recording format	AVI	
Video output format	MPEG compression	
Digital zoom	Adjustable from 1x to 8x zoom	
Field of view	68°	
Depth of field	25 mm to infinity	
Video resolution	Standard	720p
Minimum focus distance	10 mm	
Focus type	Fixed	
Rotation	180°	
Streaming video		Via HDMI and Fluke Connect™
LCD screen		
Touch screen		Capacitive touch screen
Size	7 inch (17.79 cm)	
Refresh rate	30 hz	
UpisUp™ technology	Real-time upright adjustment for image	
LED backlight	Adjust display brightness for optimal viewing	
Communication		
Wireless interface		WiFi 802.11b/g/n, Range: 33 feet (10.06 meters)
Data transfer	USB	USB and micro HDMI cable
Fluke Connect™*		Save and share images directly from the diagnostic scope. Attach images or video to an asset record or work order.
Instant upload to the cloud		Yes, with Fluke Connect™
General features		
Color palettes	Visible light, grayscale or inverted	
Internal memory	6 GB	
Physical buttons	Intuitive, easy to navigate button technology, 4 functional keys, 4 navigational, one capture or select button	
Carrying case	Protective EVA case	
Strap	Hand strap	Hand strap and neck strap
Power adapter	AC adapter/battery charger input	
Battery	6400mAh 3.7 volt rechargeable internal li-ion battery	
Battery life	3 hours at 50 % LED brightness	
Dimensions	6.98 x 8.85 inches (17.73 x 22.48 cm)	
Weight	1.95 lbs (0.88 Kg)	
IP rating		
Tablet	IP54, dust protected and protected against water projected from a nozzle	
Probe	IP68, dust tight and immersion of 1 meter or more depth	
Drop test	2 meter (6.56 feet)	
Operating temperature	0 °C to 45 °C (32 °F to 113 °F), 50 °C (122 °F) for less than 10 minutes	
Storage temperature	-40 °C to 60 °C (-40 °F to 140 °F)	
Operating humidity	90 % at 35 °C (95 °F) 75 % at 40 °C (104 °F) 45 % at 50 °C (122 °F)	
Warranty	2 years	

*Fluke Connect™ app and Fluke Connect™ products not available in all countries.

Fluke Connect™ functionality will be available for the DS703 FS Videoscope soon. This powerful software will allow you to save and share high-resolution images with your team. Watch the Fluke website for this firmware update and add the power of Fluke Connect to your DS703 FC Videoscope.

THERMOGRAPHY SELECTION GUIDE



Model	PTi120
Key features	
IFOV (spatial resolution)	7.6 mRad
Infrared resolution	120 x 90 (10,800pixels)
Field of view	50° H x 38° V
Distance to spot	130:1
Temperature measurement range (not calibrated below -10 °C)	-20 ° C to 150 ° C
Focus system	Fixed focus, minimum focus distance 50 cm
USB	Mini USB used to transfer image to PC
Wifi	Yes (802.11 b/g/n (2.4 GHz))
Fluke Connect™ Instant Upload	Yes, connect your camera to your building's WiFi network, (802.11 b/g/n (2.4 GHz)), and images taken automatically upload to the Fluke Connect system or your local server for storage and viewing on your PC
Image quality	
IR-Fusion™ technology	AutoBlend continuous 0 % to 100 %. Adds the context of the visible details to your infrared image.
Touchscreen display	3.5" (landscape), 320 x 240 LCD
Thermal sensitivity (NETD)	60 mK
Frame rate	9 Hz
Data storage and image capture	
Memory	≥ 2 GB internal flash memory
Image capture, review, save mechanism	One-handed image capture, review, and save capability
Image file formats	Non-radiometric (jpeg), or fully radiometric (.is2); no analysis software required for non-radiometric (jpeg) files
Software	Fluke Connect desktop software—full analysis and reporting software with access to the Fluke Connect system
Export file formats with software	JPG, IS2
Battery	
Batteries (rechargeable)	Internal rechargeable lithium ion battery
Battery life	≥ 2 hours continuous (without WiFi)
Battery charging time	≤ 1.5 hours
Battery charging system	Micro USB port
AC operation	With separate AC to USB adapter. Not included in box
Power saving	Automatic Shutdown: 5, 10, 15 and 20 minutes or never
Temperature measurement	
Temperature measurement range (not calibrated below -10 °C)	-20 ° C to 150 ° C (-4 ° F to 302 ° F)
Accuracy	Target temp at or over 0 °C: Accuracy: ± 2 ° C or ± 2 %, whichever is greater
On-screen emissivity correction	Yes
On-screen reflected background temperature compensation	Yes
Center-point temperature	Yes
Spot temperature	Hot and cold spot markers
Color palettes	
Standard palettes	6: Ironbow, Blue-Red, High Contrast, Amber, Hot Metal, Grayscale
General specifications	
Infrared spectral band	8 μ m to 14 μ m (long wave)
Operating temperature	-10 ° C to +50 ° C (14 ° F to 122 ° F)
Storage temperature	-40 ° C to +70 ° C (-40 ° F to 158 ° F)
Relative humidity	95 % non-condensing
Safety	IEC 61010-1: Pollution Degree 2
Electromagnetic compatibility	EN 61326-1, CISPR 11: Group 1, Class A
US FCC	47 CFR 15 Subpart C
Vibration and shock	10 Hz to 150 Hz, 0.15 mm, IEC 60068-2-6; 30 g, 11 ms, IEC 60068-2-27
Drop	1 meter
Size (H x W x L)	8.9 cm x 12.7 cm x 2.5 cm (3.5 in x 5.0 in x 1.0 in)
Weight	0.233 kg (0.514 lb)
Enclosure rating	IP54
Warranty	Two-years
Supported languages	Czech, Dutch, English, Finnish, French, German, Hungarian, Italian, Japanese, Korean, Polish, Portuguese, Russian, Simplified Chinese, Spanish, Swedish, Traditional Chinese, and Turkish

THERMOGRAPHY SELECTION GUIDE CONTINUED



Model	Ti401 PRO	Ti480 PRO	TiX501	TiX580
Key features				
Infrared resolution	640 x 480 (307,200 pixels)			
SuperResolution	No	Yes, in software. Captures and combines 4x the data to create a 1280 x 960 image	No	Yes, in software. Captures and combines 4x the data to create a 1280 x 960 image
IFOV with standard lens (spatial resolution)	0.93 mRad, D:S 1065:1			
Field of view	34 °H x 24 °V			
Minimum focus distance	15 cm (approx. 6 in)			
MultiSharp Focus	No	Yes, focused near and far, throughout the field of view	No	Yes, focused near and far, throughout the field of view
LaserSharp™ Auto Focus	Yes, for consistently in-focus images. Every. Single. Time			
Laser distance meter	Yes, calculates distance to the target for precisely focused images and displays distance on screen			
Advanced manual focus	Yes			
Wireless connectivity	Yes, to PC, iPhone® and iPad® (iOS 4s and later), Android™ 4.3 and up, and WiFi to LAN (where available)			
Fluke Connect™ app compatible	Yes*, connect your camera to your smartphone, and images taken automatically upload to the Fluke Connect app for saving and sharing			
Fluke Connect Assets	Through the desktop, assign images to assets, easily compare measurement types in one location and create reports		Future**, Automatically assign images to assets, easily compare measurement types in one location and create reports through a cloud-based system	
Fluke Connect instant cloud upload	Yes*, connect your camera to your building's WiFi network, and images taken automatically upload to the Fluke Connect system for viewing on your smartphone or PC			
Fluke Connect instant server upload	Yes**			
IR-Fusion™ technology	Yes, adds the context of the visible details to your infrared image			
Ruggedized touchscreen display	3.5 inch (landscape), 640 x 480 LCD		5.7 inch (14.4 cm) landscape 640 x 480 LCD	
Ergonomic design	Pistol-grip design for one-handed use		240 ° rotatable (articulating) lens	
Thermal sensitivity (NETD)**	≤ 0.075 °C at 30 °C target temp (75 mK)	≤ 0.05 °C at 30 °C target temp (50 mK)	≤ 0.075 °C at 30 °C target temp (75 mK)	≤ 0.05 °C at 30 °C target temp (50 mK)
Level and span	Smooth auto and manual scaling			
Touchscreen adjustable level/span	Yes. Span and level can be easily and quickly set by simply touching the screen			
Fast auto toggle between manual and auto modes	Yes			
Fast auto-rescale in manual mode	Yes			
Minimum span (in manual mode)	2.0 °C (3.6 °F)			
Minimum span (in auto mode)	3.0 °C (5.4 °F)			
Built-in digital camera (visible light)	5MP			
Frame rate	60 Hz or 9 Hz versions			
Laser pointer	Yes			
LED light (torch)	Yes			
Digital Zoom	No	2x and 4x	2x	2x, 4x, 8x
Data storage and image capture				
Extensive memory options	Removable 4 GB micro SD memory card, 4 GB internal flash memory, save to USB flash drive capability, upload for permanent storage			
Image capture, review, save mechanism	One-handed image capture, review, and save capability		Yes, edit and analyze captured images on camera	
Image file formats	bmp, jpeg, is2	bmp, jpeg, is2, is3, AVI	bmp, jpeg, is2, is3, AVI	bmp, jpeg, is2, is3, AVI
Memory review	Thumbnail and full screen review			
Software	Full analysis and reporting software with access to the Fluke Connect system			
Analyze and store radiometric data on a PC	Yes			
Export file formats with Fluke Connect software	Bitmap (.bmp), GIF, JPEG, PNG, TIFF			
Voice annotation	60 seconds maximum recording time per image; reviewable playback on camera, optional Bluetooth headset available but not required			
IR-PhotoNotes™	Yes - 2 images	Yes - 5 images	Yes - 2 images	Yes - 5 images
Text annotations	Yes. Including standard shortcuts as well as user programmable options			
Video recording and formats	No	Standard and radiometric	Standard	Standard and radiometric
Remote control operations	Remote display through Fluke Connect	Remote display and control operation through Fluke Connect	Remote display through Fluke Connect	Remote display and control operation through Fluke Connect
Auto capture (temperature and interval)	No	Yes	No	Yes
MATLAB® and LabVIEW® tool boxes	- Integrate camera data, infrared video and images into software to support R&D analysis			

THERMOGRAPHY SELECTION GUIDE CONTINUED

Model	Ti401 PRO	Ti480 PRO	TiX501	TiX580
Battery				
Batteries (field-replaceable, rechargeable)	Two Lithium-ion rechargeable smart battery packs with five-segment LED display to show charge level			
Battery life	2-3 hours per battery (actual life varies depending on settings and usage)			
Battery charging time	2.5 hours to full charge			
Battery charging system	Two-bay battery charger or in-imager charging. Optional 12 V automotive charging adapter			
AC operation	AC operation with included power supply (100 V AC to 240 V AC, 50/60 Hz)			
Power saving	User selectable sleep and power off modes			
Temperature measurement				
Temperature measurement range (not calibrated below -10 °C)	-20 °C to +650 °C (-4 °F to +1,202 °F)	-20 °C to +1,000 °C (-4 °F to 1,832 °F)	-20 °C to +650 °C (-4 °F to +1,202 °F)	-20 °C to +1,000 °C (-4 °F to 1,832 °F)
Accuracy	± 2 °C or 2 % (whichever is greater) at 25 °C ambient			
On-screen emissivity correction	Yes (both value and table)			
On-screen reflected background temperature compensation	Yes			
On-screen transmission correction	Yes			
Line temperature graph	No	Yes	No	Yes
Color palettes				
Standard palettes	9: Rainbow, Ironbow, Blue-Red, High Contrast, Amber, Amber Inverted, Hot Metal, Grayscale, Grayscale Inverted		8: Ironbow, Blue-Red, High Contrast, Amber, Amber Inverted, Hot Metal, Grayscale, Grayscale Inverted	
Ultra Contrast palettes	9: Rainbow, Ironbow, Blue-Red, High Contrast, Amber, Amber Inverted, Hot Metal, Grayscale, Grayscale Inverted		8: Ironbow Ultra, Blue-Red Ultra, High Contrast Ultra, Amber Ultra, Amber Inverted Ultra, Hot Metal Ultra, Grayscale Ultra, Grayscale Inverted Ultra	
Smart lenses				
Macro-25 micron lens: 25 MAC2	Yes			
2 x telephoto lens: TELE 2	Yes			
4 x telephoto lens: TELE4	Yes			
Wide angle lens: WIDE 2	Yes			
General specifications				
Color alarms (temperature alarms)	High temperature, low temperature, and isotherms (within range)			
Infrared spectral band	7.5 µm to 14 µm (long wave)			
Operating Temperature	-10 °C to +50 °C (14 °F to 122 °F)			
Storage Temperature	-20 °C to +50 °C (-4 °F to 122 °F) without batteries			
Relative humidity	10 % to 95 % non-condensing			
Center-point temperature measurement	Yes			
Spot temperature	Hot and cold spot markers		Hot and cold spot markers, individually enabled	
User-definable spot markers	No	3 user-definable spot markers	2 user-definable spot markers	3 user-definable spot markers
User defined measurement boxes	1 expandable-contractible measurement box with MIN-MAX-AVG temp display	Up to 3 expandable-contractible measurement box with MIN-MAX-AVG temp display	1 expandable-contractible measurement box with MIN-MAX-AVG temp display	3-Expandable-contractible measurement box with MIN-MAX-AVG temp displ
Hard Case	Rugged, hard carrying case; soft transport bag	Rugged, IP67 rated, airtight hardcase with custom foam insert		
Safety	IEC 61010-1: Overvoltage category II, Pollution Degree 2			
Electromagnetic compatibility	IEC 61326-1: Basic EM environment. CISPR 11: Group 1, Class A			
Australian RCM	IEC 61326-1			
US FCC	CFR 47, Part 15 Subpart B			
Vibration	0.03 g ² /Hz (3.8 g), 2.5 g IEC 60068-2-6			
Shock	25 g, IEC 68-2-29			
Drop	Engineered to withstand 2 meter (6.5 feet) drop with standard lens		Engineered to withstand 1 meter (3.3 feet) drop with standard lens	
Size (H x W x L)	27.7 cm x 12.2 cm x 16.7 cm (10.9 in x 4.8 in x 6.5 in)		27.3 cm x 15.9 cm x 9.7 cm (10.8 in x 6.3 in x 3.8 in)	
Weight (battery included)	1.04 kg (2.3 lb)		1.54 kg (3.4 lb)	
Enclosure rating	IEC 60529: IP54 (protected against dust, limited ingress; protection against water spray from all directions)			
Warranty	Two-years (standard), extended warranties are available			
Recommended calibration cycle	Two-years (assumes normal operation and normal aging)			
Supported languages	Czech, Dutch, English, Finnish, French, German, Hungarian, Italian, Japanese, Korean, Polish, Portuguese, Russian, Simplified Chinese, Spanish, Swedish, Traditional Chinese, and Turkish			
RoHS compliant	Yes			

Please Note: Fluke Connect analysis and reporting software is available in all countries but Fluke Connect is not. Please check availability with your authorized Fluke distributor
 **Indicates Fluke Connect™ features that will be available soon. Watch the Fluke website for software and firmware updates.

VIBRATION AND ALIGNMENT TOOLS

Get answers now

In the world of mechanical maintenance, vibration remains one of the earliest indicators of a machine's health. Whether it's the rumble of worn bearings or the shaking, shimmying or thumping of loose, misaligned or unbalanced parts, machines have a tale to tell. For years, mechanical teams faced a tough choice when it came to vibration and alignment testing: complex vibration analysis systems, expensive vibration consultants, or relying on the trained ears of seasoned technicians using low-resolution test methods, or complex math.

Now you can get fast, accurate and actionable answers with revolutionary vibration and alignment testers from Fluke. These tools redefine testing for mechanical troubleshooting and predictive maintenance, which helps you:

- Quickly and reliably understand machinery health and condition severity
- Increase efficiency by working against a prioritized list of problems
- Take control of downtime costs by anticipating problems earlier and identifying root causes of recurring failures
- Conduct vibration and alignment checks, and perform expert level corrections with minimal training



FEATURED PRODUCTS



Fluke 805 FC Vibration Meter

Make go or no-go maintenance decisions with confidence

The fast, easy-to-use Fluke 805 FC Vibration Meter eliminates the confusion of vibration screening so you can make go or no-go maintenance decisions with confidence. Instantly upload your data to the Fluke Connect™ app and share vibration measurement results with your maintenance team in real time—all without leaving the field.*

- The innovative sensor and sensor tip design ensures accurate measurements for overall vibration measurement, bearing condition and machine health
- A four-level scale helps you quickly assess problem severity
- Set up machine profiles, create work orders and send maintenance routes to technicians in the field using the Fluke Connect mobile app

*Fluke Connect is not available in all countries. Check with your local Fluke representative.



Fluke 810 Vibration Tester

Take a vibration expert along

The Fluke 810 Vibration Tester is the most advanced machine diagnostic tool for mechanical maintenance teams who need an answer now. A simple step-by-step process reports on machine faults the first time measurements are taken, without prior measurement history.

- The unique automated diagnostic technology identifies and locates the most common mechanical faults: bearings, misalignment, unbalance and looseness
- Repair recommendations advise technicians on corrective action
- Real-time tips and guidance give new users on-board, context-sensitive help



Fluke 830 Laser Shaft Alignment Tool

Precision shaft alignment made easy

The Fluke 830 Laser Shaft Alignment Tool is the ideal test tool to precision-align rotating shafts in your facility. If you're still using rulers and dial indicators to ensure your rotating machinery is properly aligned, you could be losing thousands of dollars per year in replacement bearing costs, hours of unnecessary repair time and crippling unplanned downtime, not to mention taking years off your machine's useful life.

- The single-laser measurement technology results in better data accuracy
- The intuitive guided user interface helps you quickly and easily complete machine alignments
- An activated electronic inclinometer means measurements are flexible, reliable and repeatable
- The dynamic machine tolerance check provides continuous evaluation of alignment adjustments so you know when your machine is in an acceptable range



Fluke 820-2 LED Stroboscope

Rugged, compact and easy-to-use stop-motion diagnostic tool

With the Fluke 820-2 LED Stroboscope, investigate and observe potential mechanism failure with confidence on a variety of machinery, in a wide range of industries, without making physical contact with the machine. The Fluke 820-2 LED Stroboscope is a rugged, compact, portable strobe ideal for stop-motion diagnostics, mechanical troubleshooting and process or product research and development.

- Identify the running speed of rotating equipment without stopping the operation or making contact with machinery
- Stop motion for diagnoses of parasitic oscillations, flaws, slippage or unwanted distortions
- Measure speed of rotation or frequency of a rotating shaft, speaker or mechanical part
- Identify part numbers or other markings

INSULATED HAND TOOLS

Safe. Rugged. Fluke. 1000 volt insulated hand tools. Lifetime warranty.

Fluke is the world leader in handheld test tools. Everything that you know about Fluke multimeters, clamp meters and electrical test tools applies to our insulated hand tools:

These rugged hand tools are built to last a lifetime. That's why they carry a lifetime warranty.* If a Fluke insulated hand tool is defective, take it to a distributor for replacement.

Fluke insulated tools always feel right. From the moment you first put them in your hand, you're ready to go to work. The pliers offer a smooth, solid motion, without needing to be broken in. The screwdrivers give you maximum torque and a comfortable grip that reduces fatigue.

Take everything that makes Fluke test tools great and put that into insulated hand tools. That's what you'll have on your tool belt.

Not available in all countries

* Industrial product limited Lifetime Warranty

Each Fluke insulated hand tool will be free from defects in material and workmanship for its lifetime. Lifetime is defined as seven years after Fluke discontinues manufacturing the product, but the warranty period shall be at least fifteen years from the date of purchase. The warranty does not cover damage from neglect, misuse, contamination, alteration, accident or abnormal conditions of operation or handling, including damage caused by use outside of the product's intended use. This warranty covers the original purchaser only and it is not transferable. To establish original ownership proof of purchase is required.



FEATURED PRODUCTS

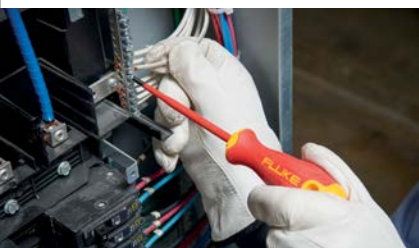

Fluke Insulated Screwdrivers

The job isn't finished until everything is tightened down. Precision insulated tools fit and rip the fastener properly to apply maximum torque without damage to the head. Hardened chromium-molybdenum-vanadium steel blades minimize wear. The last thing you want is to have your driver slip out of the screw head and possibly contact a nearby conductor.

Fluke offers three styles and multiple sizes—seven drivers in all. All certified to 1000 volts ac and 1500 V dc. Every screwdriver individually tested to 10,000 volts.

- The ergonomic handle adapts to the user's hand, causing less strain and work fatigue and providing maximum torque
- The full length, impact-proof handle core is coated with soft-grip outer material and has a hanging hole for extra security and an anti-roll handle design
- The slim insulated shaft allows access in hard to reach areas
- All blades are manufactured from German CMV steel for superior durability

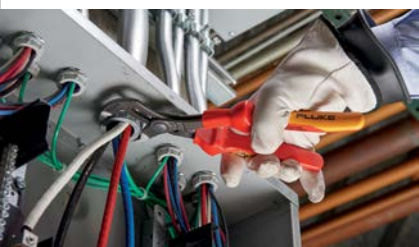
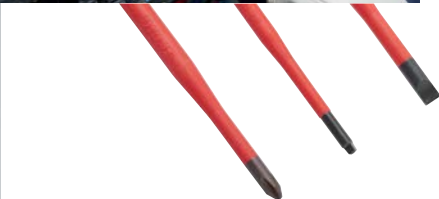

Fluke Insulated Pliers and Cutters

Wires need cutting. Cables need pulling. Knockouts need twisting. Sometimes things just need holding. Fluke insulated pliers and cutters give you a range of options when the job requires jaws with bite. All of them are built with German CMV steel.

Long nose pliers with side cutter and gripping zones

- Unique milled wave patten gripping zones
- Straight, half-round, long and slim knurled jaws, specially profiled
- Side cutting edge for wire cutting



Heavy-duty, high-leverage diagonal cutter

- Cuts hard materials including steel and piano wire
- Power joint and precision cutting edges



Fast adjust pump pliers

- 27 jaw adjustment steps for more accurate gripping of the workpiece with less slippage than other designs
- Self-locking on pipes and nuts: no slipping on the workpiece, with low hand force required
- Gripping surfaces with teeth hardened to HRC61 for low wear and reliable gripping
- Box-joint design; high stability because of double guide
- Pinch guard that prevents operators' fingers being pinched



Heavy duty combination pliers

- Secure hold by aggressive serrated jaws and 4-point gripping hole
- Slim shape for better access to wires in tight spaces
- Powerful gripping jaw, yet 20 % lighter weight than other designs



Fluke Hand Tools Magnetic Hanging Pouch

The magnetic Hanging Pouch with multiple pockets takes care of your tools and keeps them at hand and easy to reach while you're working. Using the same design and rare-earth magnet of the TPAK Toolkit you use to hang your meters, the Magnetic Hanging Pouch keeps your tools closely hanging in panels and metal surfaces.

- Multiple pockets; holds up to three pliers and seven screwdrivers
- Protected inside
- Magnetic hanging strap

Note: Tools are not included with Magnetic Hanging Pouch

INSULATED HAND TOOLS SELECTION GUIDE



Models	Insulated screwdrivers						
	ISLS3	ISLS5	ISLS8	IPHS1	IPHS2	ISQS1	ISQS2
Screwdriver type	⊖ Slot	⊖ Slot	⊖ Slot	⊕ Phillips	⊕ Phillips	⊖ Square	⊖ Square
Blade length	3 in, 75 mm	4 in, 100 mm	5 in, 125 mm	3 in, 75 mm	4 in, 100 mm	4 in, 100 mm	5 in, 125 mm
Tip size	3/32 in, 2.5 mm	5/32 in, 4 mm	1/4 in, 6 mm	#1	#2	SQ1	SQ2
Warranty	Lifetime warranty						



Models	Insulated pliers and cutters			
	INLP8	INDC8	INPP10	INCP8
Plier type	Long nose	Diagonal cutter	Adjustable/ pump	Lineman combination
Nominal length	8 in, 200 mm	8 in, 200 mm	10 in, 250 mm	8 in, 200 mm
Warranty	Lifetime warranty			



Models	Kits and bundles								Accessories
	IKSC7	IKPL3	IKST7	IKPK7	IBT6K	IB875K	IB117K	IB179K	RUP8
Description	Insulated 7 unit Screwdriver Kit, 1,000 V	Insulated 3 Unit Pliers Kit, 1,000 V	Insulated Hand Tools Starter Kit, 1,000 V	Fluke Pack30 Professional Tool Backpack + Insulated Hand Tools Starter Kit	Fluke T6 Electrical Tester + Insulated Hand Tools Starter Kit	Fluke 87V Industrial Multimeter + Insulated Hand Tools Starter Kit	Fluke 117 Electrician's Multimeter + Insulated Hand Tools Starter Kit	Fluke 179 True-RMS Digital Multimeter + Insulated Hand Tools Starter Kit	Roll-up tool pouch. Holds up to 3 pliers and 5 screwdrivers, rolls shut, closes with hook and loop fasteners
Included	3 slotted tips, 2 Phillips tips, 2 square drive tips	Long nose pliers, heavy duty diagonal cutter, heavy duty combo pliers, roll-up tool pouch	3 slotted tips, 2 Phillips tips, long nose pliers, diagonal cutter, linesman combination plier, roll-up tool pouch	Fluke Pack30 Professional tool backpack, 3 slotted tips, 2 Phillips tips, long nose pliers, diagonal cutter, combination pliers, roll-up tool pouch	Fluke T6 Electrical Tester, 3 slotted tips, 2 Phillips tips, long nose pliers, diagonal cutter, combination pliers, roll-up tool pouch	Fluke 87V Industrial Multimeter, 3 slotted tips, 2 Phillips tips, long nose pliers, diagonal cutter, combination pliers, roll-up tool pouch	Fluke 117 Electrician's Multimeter, 3 slotted tips, 2 Phillips tips, long nose pliers, diagonal cutter, combination pliers, roll-up tool pouch	Fluke 179 True-RMS Digital Multimeter, 3 slotted tips, 2 Phillips tips, long nose pliers, diagonal cutter, combination pliers, roll-up tool pouch	Tools not included
Warranty	Lifetime	Lifetime	Lifetime	1 year*	2 year*	Lifetime	3 year*	Lifetime	1 year

ACCESSORIES

Genuine Fluke accessories

You've already invested in a Fluke tool. Now expand its capabilities with Fluke genuine accessories.

Fluke accessories increase the functionality of your test tool as well as your safety and proficiency. Your digital multimeter can become a thermometer, clamp meter, or even a pressure gauge. With Fluke genuine accessories, you can broaden the ability to take meter measurements in different environments to meet your industrial, electrical, and electronic needs.

Get the right case to protect your tools, and with our breadth of soft tool pouches and hard cases available, you're never short on choices. Other available accessories include fuses, current probes and hat lights, magnetic meter and case hangers, and appropriately rated test lead probes that improve your safety and proficiency.



FEATURED ACCESSORIES

Fluke TL175 TwistGuard™ Test Leads

Twist. Test. Comply.

The Fluke TL175 TwistGuard Test Leads offer adjustable length test tips for use in different measurement and safety rated environments. By simply twisting the test lead, the user can change the exposed probe tip length from 19 mm to 4 mm (0.75 in to 0.16 in).

The patented TwistGuard extendable tip shroud meets new electrical safety requirements to reduce tip exposure while providing the versatility needed for most measurements.

TL175 test leads come with the WearGuard™ lead wire wear indicator. Each test lead is covered by two layers of silicone insulation; the inner contrasting color is exposed when the leads are nicked, scuffed or otherwise damaged—a great indicator for replacing compromised leads.

- Probes comply with EN61010-031 requirements
- Rated CAT II 1000 V, CAT III 1000 V, CAT IV 600 V, 10 A max., Pollution Degree 2
- Environmental ratings: -20 °C to +55 °C (-4 °F to +131 °F) altitude: 2000 m (6562 ft)



Fluke TPAK Meter Hanging Kit

Free both hands to make measurements

Hang your meter in a variety of ways for convenient, hands-free operation and to solve any hanging and positioning problems you may face.

- Powerful (rare earth) magnetic hanger: allows you to hang the meter on any metallic surfaces, freeing both hands for conducting tests
- 9 in hook-and-loop strap: allows you to loop around pipes
- Hook hanger: for hanging on nonmagnetic surfaces
- General purpose hanger: allows you to hang your meter on nails, hooks and many other objects

Always demand the best: use the original TPAK Meter Hanging Kit with its unique rare earth magnet for superior gripping strength to ensure your tools don't slide or fall.



Fluke Pack30 Professional Tool Backpack

Designed for maintenance professionals

The Fluke Pack30 backpack for the professional tradesman is rugged yet weighs less than 6.5 pounds. It's built with durable, high-quality polyester and features over 30 heavy-duty pockets for storing and carrying your tools to the next job. The primary storage compartments hold test tools, hand tools, and a 12" laptop or tablet; a smaller molded pocket for protection of smaller items. The rugged waterproof molded bottom offers protection from the elements and keeps the backpack standing for convenient access to tools.

- Lightweight, weighs less than 6.5 pounds to take the load off your back
- Rugged, waterproof bottom base protects tools, keeping the backpack upright for easy access to tools
- Over 30 pockets in three main storage compartments
- Clips, brackets and straps on the outside of the Fluke Pack30 for frequently used tools such as tape rolls, measuring tapes and voltage detectors
- Stores, organizes and protects test equipment, hand tools, safety glasses and personal items like your keys, wallet and phone



	General purpose measurements	μ V measurements	Electronics, hard to reach areas		
Test Leads					
Description	TL175 TwistGuard™ Test Leads <ul style="list-style-type: none"> Patented TwistGuard™ extendable tip shroud reduces tip exposure while providing the versatility needed for most measurements WearGuard™ test lead wear indicator show white inner layer when leads are damaged or worn and in need of replacement 	TL75 Hard Point Test Lead Set One pair of comfort grip probes with PVC-insulated, right-angle shrouded 4 mm (0.16 in) banana plugs	TL71 Premium Test Lead Set One pair (red, black) comfort grip probes with silicone insulated, right-angle test leads	TL40 Retractable Tip Test Lead Set Pair of flexible silicone insulated test leads with sharp needle point tips adjustable to desired length from 0 to 76 mm	TL910 Electronic Test Probes <ul style="list-style-type: none"> Pair of red and black leads with very small tips to access hard-to-reach electronic test points Includes three sets of spring-loaded gold tips and two sets of stainless steel tips
Specifications					
Cable length	48 in	48 in	48 in	48 in	40 in
Category rating	CAT II 1000 V, CAT III 1000 V, CAT IV 600 V, 10 A max	CAT II 1000 V, 10 A rating, CAT IV 600 V, CAT III 1000 V only with protective cap	CAT II 1000 V, 10 A rating, CAT IV 600 V, CAT III 1000 V only with protective cap	CAT II 600 V, 3 A rating	CAT II 1000 V, 3 A rating
Probe tip length	19 to 4 mm (0.75 to 0.16 in)	19 mm (0.75 in)	19 mm (0.75 in)	76 to 5 mm (3 to 0.2 in)	33 to 100 mm (1.3 in to 4 in)
AC175 Alligator Clip Set compatible	•	•	•		
TP920 Probe Set compatible	•	•	•		

Extend the capabilities of your TL175, TL75 and TL71 Test Leads with

AC175 Alligator Clip Set	TP920 Test Probe Adapter Set
Description	Description
On pair (red and black) slide-on alligator clips	IC test adapters, extended probe tips and medium alligator clips

For fuse replacement check the Fluke website in the service section





Fuse selection guide







Model	Fuse Requirements
115, 117, 233	P/N 803293 11A, 1000V fuse
175, 177, 179, 83V, 87V, 287, 289, 27II, 28II, 88V, 77IV	P/N 803293 11A, 1000V fuse P/N 943121 440 mA, 1000V fuse
3000 FC, 1577, 1587 FC	P/N 943121 440 mA 1000V fuse
787, 789	P/N 943121 440 mA 1000V fuse (Qty 2)
1503, 1507	P/N 2279339 315 mA 1000V fuse
28II EX	P/N 803293 11A, 1000V fuse P/N 4016494 440mA fuse assembly







For fuse replacement check the Fluke website in the service section

MODULAR TEST LEADS

Modular test leads				
				
	TL221 SureGrip™ Test Lead Extension Set	TL222 SureGrip™ Silicone Insulated Test Leads	TL224 SureGrip™ Insulated Test Leads	TL27 Heavy-Duty Test Lead Set
Description	Modular test leads provide the convenience of attaching clips, hooks and grabbers as needed. All the leads offer strain relief and include banana jack terminations that allow a great variety of test lead configurations.			
Specifications				
Cable length	1.5 m (59 in)	1.5 m (59 in)	1.5 m (59 in)	1.5 m (59 in)
Category rating	CAT III 1000 V, CAT IV 600 V, 10 A	CAT III 1000 V, CAT IV 600 V, 10 A	CAT III 1000 V, CAT IV 600 V, 10 A	CAT II 600 V, 3 A rating
Termination	Safety-shrouded 4 mm (0.16 in) banana jacks	Safety-shrouded 4 mm (0.16 in) banana jacks	Safety-shrouded 4 mm (0.16 in) banana jacks	Safety-shrouded 4 mm (0.16 in) banana jacks
Connectors	Straight connectors on both ends	Right angle connectors on both ends	Right angle in one end, straight in the other	Straight connectors on both ends

This wide variety of clips and probes allows you to configure the modular test leads to individual needs. Use with modular clips (Table A) or modular test probes (Table B).

Modular clips				
				
	AC285 SureGrip™ Alligator Clips	AC220 SureGrip™ Alligator Clips	AC280 SureGrip™ Alligator Clips	AC283 SureGrip™ Pincer Clips
Specifications				
Maximum grip	1.5 m (59 in)	1.5 m (59 in)	1.5 m (59 in)	1.5 m (59 in)
Category rating	CAT III 1000 V, CAT IV 600 V, 10 A	CAT III 1000 V, CAT IV 600 V, 10 A	CAT III 1000 V, CAT IV 600 V, 3 A	CAT II 600 V, 3 A rating
Application	Fine gauge wire to a 20 mm bolt	Screw heads	Wires and cables	Continuity testing on circuit board (diodes)

Modular test probes						
						
	TP175 TwistGuard™ Test Probes	TP220 SureGrip™ Industrial Test Probes	TP1/TP2/TP4 Slim Reach™ Test Probes	TP80 Electronic Test Probes	TP74 Lantern Tip Test Probes	TP38 Slim Reach™ Test Probes
Specifications						
Tip dimensions	19 to 4 mm (0.75 to 0.16 in)	12 mm (0.47 in)	Up to 14.7 mm (0.58 in) 1 mm (TP1) 2 mm (TP2) 4 mm (TP4) diameter probe	Up to 3.9 mm (0.157 in)	Banana style 4 mm (0.16 in) spring contacts Nickel-plated brass ends	24 mm (0.95 in), including insulated part of the tip
Category rating	CAT III 1000 V, CAT IV 600 V, while providing flexibility for CAT II measurements	CAT II 1000 V (CAT III 1000 V, CAT IV 600 V with cap), 10 A	CAT II 1000 V (CAT III 1000 V, CAT IV 600 V with cap), 10 A	CAT III 1000V, 1A	CAT II 1000 V CAT III 1000 V, CAT IV 600 V with cap, 10 A	CAT III 1000 V, CAT IV 600 V, 10 A
Application	General-purpose measurements	Industrial	Electrical	Electronics	Electrical	Electrical

Industrial, electrical and general measurements

Test lead kits for industrial, electrical and general-purpose measurements					
	TL220 SureGrip™ Industrial Test Lead Set	TLK-220 EUR SureGrip™ Industrial Test Lead Set	TLK-225-1 SureGrip™ Master Accessory Set	TLK289 EUR SureGrip™ Industrial Master Test Lead Set	TL223-1 SureGrip™ Electrical Test Lead Set
Parts included					
AC220 SureGrip™ Alligator Clip Set	•	•	•	•	•
AC285 SureGrip™ Large Jaw Alligator Clip Set		•	•	•	
AC280 SureGrip™ Hook Clips			•	•	
AC283 SureGrip™ Pincer Clips			•		
TP220 SureGrip™ Industrial Test Probes	•	•			
TL224 SureGrip™ Insulated Test Leads	•	•	•	•	•
TP175 TwistGuard™ Test Probes			•	•	
TP1 Slim Reach Test Probes (flat-bladed)					•
80BK-A Digital Multimeter Temperature Probe				•	
Case		C116 Zippered Vinyl Case	6-pocket storage pouch	C116 Zippered Vinyl Case, TPAK ToolPak™	
Safety rating	All CAT IV 600 V, CAT III 1000V	CAT II 1000 V (CAT III 1000V, CAT IV 600V with cap), 10 A	All CAT IV 600V, CAT III 1000V (CAT II 600 V, 3 A rating for AC283)	CAT II 1000 V (CAT III 1000V, CAT IV 600V with cap), 10A	CAT II 1000V, 10 A (CAT III 1000V, CAT IV 600V with cap)

Electronics

Test lead kits for electronic environments on the bench or in the field such as circuit boards and components		
TL80A Basic Electronic Test Lead Kit	TL81A Deluxe Electronic Test Lead Kit	TLK287 Electronics Master Test Lead Set
Parts included		
TL71 Premium Test Lead Set	TL71 Premium Test Lead Set	TL910 Electronic Test Probe Set
Medium Alligator Clip (CAT III 1000V, 10A)	TL224 Test Lead Set	TL224 Test Lead Set
Extended probe tips (CAT II 300V, 3A)	Insulated alligator clips (10 A)	Modular test probes (10 A)
C75 Accessory Case	Modular alligator clips (10 A)	Medium alligator clips (10 A)
	Insulated probe tip extenders (3 A)	Test lead couplers
	Modular test probes (10 A)	Precision electronic replacement probe tips
	Modular hook-style clip test leads (5 A)	Rotating micrograbber set (2 A)
	Modular pinch-style clip test leads (5 A)	Banana plug/.025 SQ receptacle lead set
	Slide-on IC probe tips (3 A)	Modular hook-style clip test leads (5 A)
	Test lead couplers	Spade lug to banana jack adapters (10 A)
	Spade lug to banana jack adapters (10 A)	Pouch
	Pouch	

Automotive

Test lead kits for automotive applications	
TLK281	TLK282
Parts included	
TP81 Insulation Piercing Clip Set	
TL224 SureGrip Test Lead Set	
TP220 SureGrip Test Probe Set	
AC220 SureGrip Alligator Clip Set	
AC285 SureGrip Large Jaw Alligator Clip Set	
	TP40 Automotive Back Probe Pins (five)
	TP238 SureGrip Insulated Test Probe Set
6-pocket roll-up pouch soft case	

TEMPERATURE ACCESSORIES

	Bead	Bead	HVAC	Immersion	Surface	Air	Piercing	General purpose	Industrial surface	Pipe clamp
	80BK-A	80PK-1 80PJ-1	80PK-11	80PK-22	80PK-3A	80PK-24	80PK-25 80PT-25	80PK-26	80PK-27	80PK-8
Lowest temperature	-40 °C (-40 °F)		-30 °C (-22 °F)	-40 °C (-40 °F)	0 °C (32 °F)	-40 °C (-40 °F)	K Type: -40 °C (-40 °F) T Type: -196 °C (-321 °F)	-40 °C (-40 °F)	-127 °C (-196 °F)	-29 °C (-20 °F)
Highest temperature	260 °C (500 °F)		105 °C (221 °F)	1090 °C (1994 °F)	260 °C (500 °F)	816 °C (1500 °F)	350 °C (662 °F)	816 °C (1500 °F)	600 °C (1112 °F)	149 °C (300.2 °F)
Probe material	Type K wire with teflon insulation		Hook an loop fastener	Inconel 600	Type K sensor with teflon body	Inconel	316 Stainless Steel	304 Stainless Steel		Type K sensor with PVC body
Probe length	1 m lead wire		19 in hook and loop cuff	21.27 cm (8.375 in)	9.525 cm (3.75 in)	21.59 cm (8.5 in)	10.16 cm (4 in)	21.57 cm (8.5 in)	20.32 cm (8 in)	For pipes from 6.4 mm (.25 in) to 34.9 mm (1.375 in)
Cable length	1 m (3.3 ft)				1.3 m (4 ft)		1 m (3.3 ft)			
Connection	Standard banana jack		Molded thermocouple plug							
SureGrip™ handle			•							
Key feature	Ideal for initial troubleshooting. Can be secured in place with a magnet.		Hook an loop probe allows hands-free temperature measurement.	For use in liquids or in gels.	Exposed junction for direct contact with flat or slightly convex surfaces.	Perforated baffle for air and noncaustic gas measurements.	Probe material safe for use in foods. Sharp tip pierces solid surfaces.	Use for general-purpose air or surface measurements.	Low-conductivity stainless steel minimizes thermal shunting. Extra rugged.	Clamps securely to pipe. Measurements are repeatable to 0.56 °C (1 °F)
Thermocouple types	K	K, J	K	K			K, T	K		
Typical use										
General purpose	•									
HVAC	•		•							
Food service	•		•							
Industrial	•		•							
Residential	•		•							
Commercial	•		•							

Temperature accessories selection guide

	113/114/115/116/117	175/177	179	233	3000 FC DMM	287/289	27-II/28-II	8845A/8846A/8808A	77 IV	83 V	87 V/88V	43B	120 Series	190 Series II	1577	1587 FC	51/52/53/54-II	561	566/568/572-2	705/707	714	715	724/725	753/754	787/789	
Contact probes																										
80PK-1/80PK-27	1	1	2	2	2	2	1	1	1	2	1	1	1	1	2	•	•	•	1	•	1	•	•	•	1	
80PJ-1/80PJ-9																										1
80PT-25																										
DMM probes																										
80AK-A	•3		•	•		•	•5			•					•	•										
80BK-A	•3		•	•		•	•5			•					•	•										
80TK	•						•6	•	•	•		•	•	•	•											•
80T-150UA	•	•	•	•	•	•	•	•	•	•	•	•	•	•	•	•	•	•	•	•	•	•	•	•	•	•
Miscellaneous																										
80CK-M	1	1	2	2	2	2	1	1	1	2	1	1	1	1	2	•	•	•	1	•	1	•	•	•	•	1
80CJ-M																										
80PK-EXT (4)	1	1	2	2	2	2	1	1	1	2	1	1	1	1	2	•	•	•	1	•	1	•	•	•	•	1
80PJ-EXT																										
80PT-EXT																										
80PT-EXT																										

SureGrip™ temperature accessories

The innovative SureGrip design from Fluke is now available in select temperature probes. The soft rubber handle combined with a new ergonomic shape is so comfortable to hold that you'll forget about the probe and focus on the measurement. All SureGrip probes have an improved, more flexible strain relief for a long life.



Cleans up with soap and water

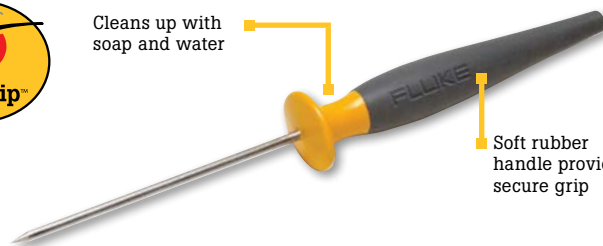

Soft rubber handle provides a secure grip

Soft cases					
	C23 Soft Carrying Case	C25 Large Soft Case for DMMs	C35 Soft Carrying Case	C150 Soft Carrying Case	C280 Soft Carrying Case
Description	Zippered case with belt loop and an inner pocket	Zippered carrying case with padding and inside pocket	Opens laterally, allowing the use of test tool without removing it. Includes a hook-and-loop strap.	Zippered carrying case with inner pocket for test leads and accessories	Designed for large tools. Includes shoulder strap and inner front pocket and dual pouches for tools
Material	Durable vinyl	Polyester	Durable polyester 600D	Durable polyester 600D	Durable polyester 600D
Dimensions (H x W x D)	225 x 95 x 58 mm 8.9 x 3.75 x 2.3 in	218 x 128 x 64 mm 8.6 x 5 x 2.52 in	220 x 140 x 65 mm 8.7 x 5.5 x 2.6 in	298 x 114 x 56 mm 11.75 x 4.5 x 2.2 in	230 x 185 x 65 mm 9 x 7.3 x 2.6 in
Recommended for:*	Fluke 61/65 IR Thermometers, 321/322 Clamp Meters	11x series, 87v, 32x series and most mid-sized DMMs	11x series, 87v, 32x series and most mid-sized DMMs	37x series, T5, T90/110/130/150	287, 289 and other larger tools







Hard cases					
	C101 Hard Case	C100 Universal Carrying Case	C20 Hard Case	C800 Meter and Accessory Case	CXT1000 Extreme Case
Description	Tough polypropylene case with configurable diced foam interior to store and protect tools	Large, tough polypropylene case with carrying handle	Heavy-duty construction with handle and storage, designed to hold a meter and accessories	Tough polypropylene case with handle, snap-on detachable lid and compartments for accessories	Features a diced foam interior for custom storage and automatic purge valve for quick equalization
Dimensions (H x W x D)	Exterior: 305 x 360 x 105 mm (12 x 14.2 x 4.1 in) Interior: 230 x 290 x 65 mm (9 x 11.5 x 2.5 in)	397 x 346 x 122 mm 15.7 x 13.6 x 4.8 in	256 x 154 x 106 mm 10 x 6.1 x 4.2 in	230 x 385 x 115 mm 9 x 15 x 4.5 in	343 x 465 x 178 mm 13.5 x 18.3 x 7 in



Specialty cases: camo and leather				
	C520a Leather Tester Case	C510 Leather Meter Case	CAMO C-25	Camo C-37
Material	Rugged leather	Rugged leather	High-quality 1000D fabric	High-quality 1000D fabric
Dimensions (H x W x D)	256 x 154 x 106 mm 10 x 6 x 4 in	287 x 179 x 106 mm 11 x 7 x 4 in	203 x 121 x 46 mm 8 x 4.8 x 1.8 in	265 x 90 x 30 mm 10.5 x 3.5 x 1.2 in
Recommended for:*	T5/T+/T Pro	17x series, 87v 71x and 72x series	11x series, 87v, 32x series and most mid-sized DMMs	37x series, T5/T+/T Pro

Holsters			
	H5 Electrical Tester Holder	H-T6 Electrical Tester Holder	H3 Clamp Meter Holster
Dimensions (H x W x D)	192 x 90 x 38 mm 7.5 x 3.5 x 1.5 in	192 x 90 x 38 mm 7.5 x 3.5 x 1.5 in	231 x 90 x 64 mm 9 x 3.5 x 2.5 in
Recommended for:*	T3 and T5 Electrical Testers	T6 Electrical Testers	37x series, T5, T90/110/130/150







Tool bags		
	C345 Soft Case	C550 Tool Bag
Description	Zippered carrying case with inner front pocket and detachable handle and shoulder strap	Rugged, weather-resistant tool bag with zippered top, large compartment and 25 pockets
Material	Durable polyester 600D	Ballistic cloth with heavy-duty hardware
Dimensions (H x W x D)	318 x 230 x 90 mm 12.5 x 9.1 x 3.5 in	333 x 513 x 231 mm 13 x 20.2 x 9.1 in

CLAMPS

AC current clamps							
							
	i200 AC	i200s AC	i400 AC	i400s AC	i800 AC	i1000s AC	i3000s AC
Description	Small-sized single-range current clamp	Dual-range current clamp. Ideal companion to a ScopeMeter™, power quality tool or digital multimeter	Single range designed to offer maximum utility in compact shape	Compact current clamp. Ideal companion to a ScopeMeter or power quality tool.	Designed to extend the current measuring capability of a digital multimeter up to 800A	Large ac current clamp for applications in power and industrial environments	Designed as a clamp-on unit for oscilloscopes up to 3000A. Includes dual banana/BNC adapter
Connector	Banana plug	Safety-insulated BNC connector/dual banana adapter	Banana plug	Safety-insulated BNC connector	Banana plug	Safety-insulated BNC connector	Safety-insulated BNC connector/dual banana adapter
Current range	1 A to 200 A ac	0.1 A to 200 A ac	1 A to 400 A ac	0.5 A to 400 A ac	100 mA to 800 A rms ac	0.1 A to 1000 A ac	1 A to 3000 A
Frequency range	40 Hz to 40 kHz (-3 dB)	40 Hz to 40 kHz (-3 dB)	5 Hz to 20 kHz (-3 dB)	5 Hz to 10 kHz (-3 dB)	30 Hz to 10 kHz (-3 dB)	5 Hz to 100 kHz	10 Hz to 100 kHz
Safety rating	CAT III 600 V	CAT III 600 V	CAT IV 600 V, CAT III 1000 V	CAT IV 600 V, CAT III 1000 V	CAT III 600 V rms	CAT III 600 V	CAT III 600 V

Flex AC current clamps			
			
	i2000 Flex AC Current Clamp	i3000 Flex-24 or -36 AC Current Clamp	i6000 Flex-24 or -36 AC Current Clamp
Description	Flexible and lightweight measuring head allows quick and easy installation	Clamp fits large conductors and is available in 610 mm and 914 mm (24 in and 36 in)	Clamp fits large conductors and is available in 610 mm and 914 mm (24 in and 36 in)
Current range	20A, 200A and 2000A switchable	30A, 300A and 3000A switchable	60A, 600A and 6000A switchable
Frequency range	10 Hz to 20 kHz	10 Hz to 50 kHz	10 Hz to 50 kHz (-3 dB)
Safety rating	CAT III 600 V	CAT III 600 V	CAT III 600 V

The flex clamps use the Rogowski (air-corded coil) principle and can be used to measure three ranges of currents when used in conjunction with oscilloscopes, recorders or data loggers.

AC/DC current clamps						
						
	i410 AC/DC Current Clamp	i1010 AC/DC Current Clamp	80i-100s AC/DC Current Clamp	i30 AC/DC Current Clamp	i30s AC/DC Current Clamp	i310s AC/DC Current Clamp
Description	Battery Powered Clamp for hard to reach areas. On/off LED indicator	Large-jaw, battery-powered clamp for hard-to-reach areas. On/off LED indicator.	Compatible with ScopeMeter, power harmonics analyzer and multimeters	Battery clamp compatible with multimeters for nonintrusive current measurements	Battery clamp compatible with ScopeMeters for nonintrusive current measurements	Measurements in inverters, industrial controllers, automotive and waveform analysis
Connector	Banana plug	Banana plug	BNC connector	Banana plug	BNC connector	BNC connector
Current range (ac)	1 A to 400 A	1 A to 600 A ac	0.1 A to 70 A	30 mA to 20 A rms	30 mA to 20 A rms	0.1 A to 300 A
Current range (dc)	1 A to 400 A	0.5 A to 1000 A dc	0.1 A to 100 A	30 mA to 30 A	30 mA to 30 A	0.1 A to 300 A
Frequency range	3 kHz	DC to 10 kHz	1 Hz to 100 kHz	DC to 20 kHz (-0.5 dB)	DC to 100 kHz (-0.5 dB)	DC to 20 kHz
Safety rating	CAT III 600 V	CAT III 600 V rms	CAT II 600 V	CAT III 600 V	CAT III 600 V	CAT III 600 V

RECOMMENDED ACCESSORIES



Models	Digital multimeters				Clamp meters		Layout and distance	Electrical testers
	87V Industrial Multimeter	116 Digital HVAC Multimeter	289 True-rms Data Logging Multimeter	117 Electrician's Ideal Multimeter	902 FC True-rms HVAC Clamp Meter	376 FC True-rms Clamp Meter	424D Laser Distance Meter	T6-1000 Electrical Tester
Recommended accessories	<ul style="list-style-type: none"> C25 Soft Carry Case TL175 TwistGuard Test Leads TPAK Magnetic Hanging Kit 	<ul style="list-style-type: none"> C115 Soft Carry Case 80PK-8 Temperature Pipe Clamp with 80AK-A adapter TPAK Magnetic Hanging Kit 	<ul style="list-style-type: none"> C43 Soft Carry Case TL175 TwistGuard Test Leads IR3000FC BLE Adapter 	<ul style="list-style-type: none"> C115 Soft Carry Case TL71 Premium Test Lead Set TPAK Magnetic Hanging Kit 	<ul style="list-style-type: none"> C33 Soft Carry Case 80PK-8 Temperature Pipe Clamp with 80AK-A adapter TPAK Magnetic Hanging Kit 	<ul style="list-style-type: none"> TL224 SureGrip™ Silicone Insulated Test Leads TL175 TwistGuard Test Leads AC285 SureGrip Alligator Clips 	Fluke C195 Case	<ul style="list-style-type: none"> H-T6 Holster TP175 TwistGuard Test Probes AC285 SureGrip Alligator Clips



Models	Indoor air quality	Insulation testers	Power quality		Process calibration tools		Portable oscilloscopes	
	971 Temperature Humidity Meter	1587 FC Insulation Multimeter	1730 and 1740 Power Energy Loggers	430-11 Power Quality Analyzer	754 Documenting Process Calibrator	726 Precision Multifunction Process Calibrator	190-II ScopeMeter® Test Tools	120B Series ScopeMeter Test Tools
Recommended accessories	<ul style="list-style-type: none"> Fluke C550 Tool Bag LVD1A Non-Contact Voltage Tester with LED Flashlight 	<ul style="list-style-type: none"> C25 Soft Carry Case i400 AC Current Clamp TPAK Magnetic Hanging Kit 	<ul style="list-style-type: none"> PQ400 Electrical Measurement Window Fluke i17XX-flex3000/4pk iFlex® Current Clamp Fluke 17XX i40s-EL Clamp-on Current Transformers Fluke MPI Magnet Probe 1, Magnetic Probe Tips 	<ul style="list-style-type: none"> PQ400 Electrical Measurement Window Fluke i400s AC Current Clamp Fluke BP291 4800 mAh High Capacity Li-ion Battery Fluke BC430 Line Voltage Adapter/Battery Charger 	<ul style="list-style-type: none"> DPCTrack2 Calibration Management Software 750P Pressure Modules 700PTPK2 Pneumatic Test Pressure Kit 	<ul style="list-style-type: none"> TL71 Premium Test Lead Set 750P Pressure Modules 700PTPK2 Pneumatic Test Pressure Kit 	<ul style="list-style-type: none"> VPS421 High Voltage Probes EBC290 External Battery Charger for BP290 and BP291 C290 Hard Shell Protective Carrying Case 	<ul style="list-style-type: none"> BHT190 Break-Out Adapters for Industrial Bus Connections 80i-110s AC/DC Current Clamp i400s AC Current Clamp



Models	Industrial imaging					Vibration and alignment
	ii900 Sonic Industrial Imager	Ti401 PRO Thermal Imager	Ti480 PRO Thermal Imager	TiX501 Thermal Imager	TiX580 Thermal Imager	805 FC Vibration Meter
Recommended accessories	<ul style="list-style-type: none"> Rechargeable battery to 6 hours: FLK BP291 External dual-bay charger: FLK EDBC 290 Array covers, 2 pack: FLK-II900 Array Cvr 	<ul style="list-style-type: none"> Tripod Mounting: TI-TRIPOD3 Sun Visor: FLK-TI-VISOR3 Viewfinder kit: FLK-TI-EYEPIECE 2x telephoto infrared smart lens: FLK 2x LENS Wide-angle infrared smart lens: Flk 0.75X WIDE LENS 	<ul style="list-style-type: none"> Tripod Mounting: TI-TRIPOD3 Sun Visor: FLK-TI-VISOR3 Viewfinder kit: FLK-TI-EYEPIECE Wide-angle infrared smart lens: Flk 0.75X WIDE LENS 2x telephoto infrared smart lens: FLK 2x LENS 25 Micron Macro IR: FLK-LENS/25MAC2 4X telephoto IR: FLK-LENS/4XTELE2 	<ul style="list-style-type: none"> Tripod Mounting: TI-TRIPOD3 Viewfinder kit: FLK-TI-EYEPIECE 2x telephoto infrared smart lens: FLK 2x LENS Wide-angle infrared smart lens: Flk 0.75X WIDE LENS 	<ul style="list-style-type: none"> Tripod Mounting: TI-TRIPOD3 Viewfinder kit: FLK-TI-EYEPIECE Wide-angle infrared smart lens: Flk 0.75X WIDE LENS 2x telephoto infrared smart lens: FLK 2x LENS 25 Micron Macro IR: FLK-LENS/25MAC2 4X telephoto IR: FLK-LENS/4XTELE2 	<ul style="list-style-type: none"> 805ES External Vibration Sensor

INDUSTRIAL ETHERNET TOOLS

Avoid network device downtime

Cabling, copper or fiber optic, is a major cause of downtime on time-sensitive industrial networks. Losing just a few data packets in a short time can cause a machine to shut down. This is especially true in industrial environments where network cables are exposed to vibration, flexing, moisture, temperature changes and EMI from motor drives and other devices. This environment is referred to as MICE in TIA-1005-A and ISO 11801:3 standards for industrial premises.

Fluke Networks® has a range of products that can be used by plant electricians and control engineers to quickly pinpoint cable defects.

Our DSX CableAnalyzer™ can determine if a cable meets TIA and ISO standards or if it has flaws that can make cables susceptible to intermittent problems caused by harsh MICE environments.



FEATURED PRODUCTS



DSX CableAnalyzer™ Industrial Ethernet Kit

Validate that cables conform to standards and don't have flaws

Faster commissioning and less downtime

Ensure network cable performance at the machine builder when commissioning and after making changes in the plant. Find marginal cables susceptible to vibration, moisture, noise and temperature. Complete documentation stored in the cloud using LinkWare™ Live or on your PC.

Speed troubleshooting

Avoid wasting time installing bypass cables. Identify the exact type and location of cable failure—or prove it's good. Pass/Fail indication in 10 seconds.

Supports most cable types and protocols

EtherNet/IP™, PROFINET™, ModBus TCP™ EtherCAT™ and other industrial protocols. RJ45, M12-D, and M12-X connectors. Singlemode and Multimode fiber at all common wave-lengths with optional OTDR and OLTS fiber modules.



CableIQ™ Qualification Tester

CableIQ finds common cable faults and data rate

Detect Ethernet switch and link configuration, measure, and document cabling performance (10/100/1000 Mbps) data rates. Graphical display of cable wiring at each end of the cable to identify open, shorted, cross-wired connections of all 8 data lines at one time in just a few seconds.

Time Domain Reflectometry (TDR) technology will find the location of a broken wire in the ethernet cable or the overall length of the cable. Built-in tone generator helps you to locate the cable end when using an optional IntelliTone™ or Pro3000F™ tone probe.



MicroScanner™ PoE Cable Verifier

MicroScanner finds common errors and switch power capacity

Graphical display of cable wiring at each end of the cable to identify open, shorted, cross wired connections of all 8 data lines at one time in just a few seconds. Time Domain Reflectometry (TDR) technology to find the location of a broken wire in the ethernet cable, or the overall length of the cable. Built-in tone generator helps you to locate the cable end when using an optional IntelliTone™ or Pro3000F™ tone probe.

Identifies the presence and speed of an active switch connected to the cable and detects the class (0-8) from PoE, PoE+ and PoE++ (802.3 at, af, and bt) switches.

	MS-PoE	CIQ-100	DSX2-5-IE-K1
	Cable continuity	Troubleshooting	Validation and advanced troubleshooting
Validate to international standards			•
Pre-deployment acceptance tests			•
Find connections susceptible to vibration, moisture, temperature and EMC/EMI			•
Fiber optic tests			• (requires optical fiber modules)
Documentation of test results for commissioning	None	Summary results in tester	Complete results in tester, PC and Cloud
User interface	Monochrome	Monochrome	Large color touch screen
Network speed and loss tests		Basic	Tests to international standards for cable type
Connector support (without adapters)	RJ45	RJ45	RJ45, M12-D, M12-X
Continuity, length and tone generation	•	•	•

FLUKE®



Connected Solutions

2017-2018 Test Tools Catalog



Fluke. *Keeping your world up and running.®*

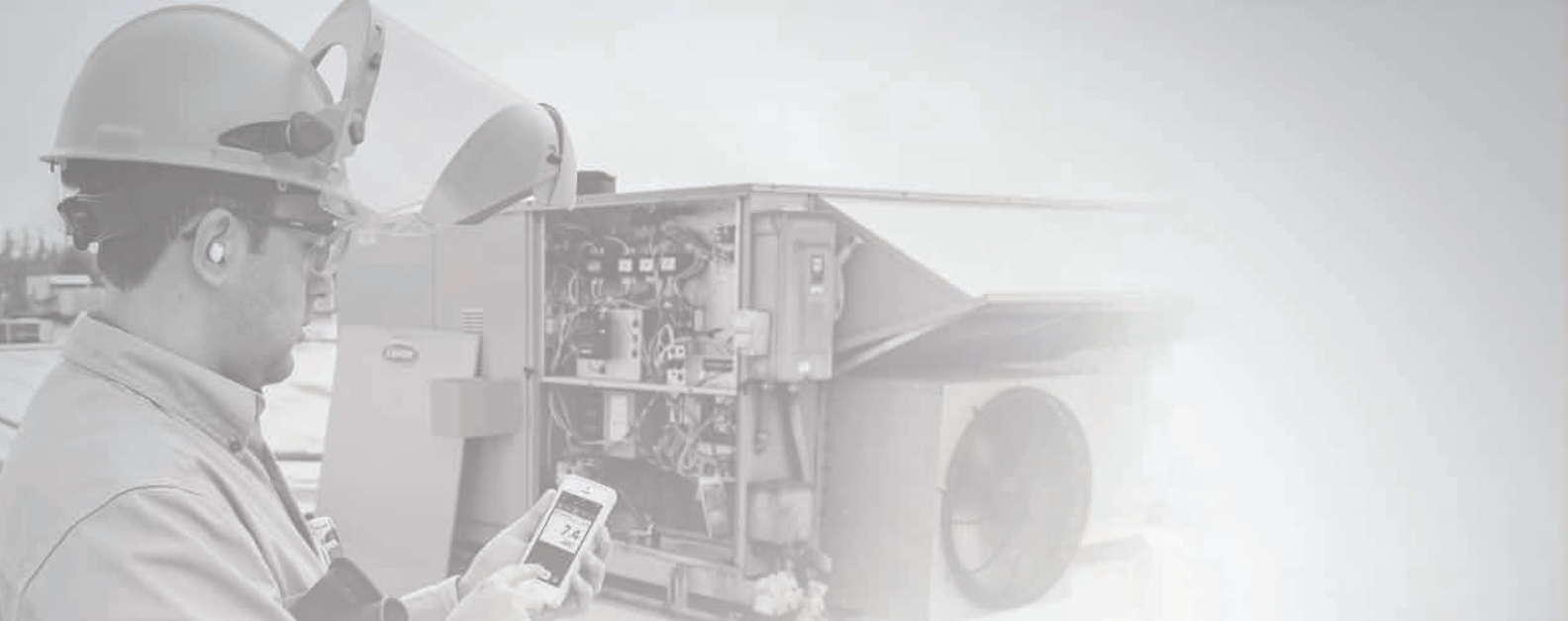

CONTENTS

What is Fluke 2-3
Resources 4

New products

Fluke Connect® 5
Fluke 279 FC 6
Fluke 376 FC 7
Fluke 902 FC 8
Fluke 438-II 9
Fluke 1664 FC, 1663, 1662 10-11
Fluke Connect compatibility guide 12
Fluke Connect wireless tools 13
Fluke TiX500, Ti450 14
Fluke TiS75 15
Fluke 154 HART 16
Fluke PRV240 17

Digital multimeters

Selection guide 18-19
Fluke 3000 FC 20
Fluke 179, 177, 175 21
Fluke 289, 287 22
Fluke 87V 23
Fluke 27-II, 28-II, 28-II EX 24
Fluke 233 25
Fluke 117, 116, 115, 114, 113 26
Fluke 88-V, 77-IV 27

Clamp Meters

Selection guide 28-29
Fluke 373, 374 FC, 375 FC, 376 FC 30
Fluke 325, 324, 323 30
Fluke 381, 365 31
Fluke 902, 368 FC, 369 FC 32
Fluke a3000 FC, a3001 FC, a3002 FC, a3003 FC, a3004 FC 33
Fluke 353, 355 34

Wireless Tools

Fluke a3000 FC, a3001 FC, a3002 FC, a3003 FC, a3004 FC 35
Fluke v3000 FC, v3001 FC 35
Fluke t3000 FC 35
Fluke ir3000 FC 35
PC300 FC 35

Bench meters

Fluke 8846A, 8845A, 8808A 36

Laser distance meters

Fluke 424D, 419D, 414D 37

Earth ground testers

Selection guide 38
Fluke 1625-2, 1623-2 38
Fluke 1625-2 Kit, 1623-2 Kit 38
Fluke 1621, 1630 39

Portable Appliance Testers

6200-2, 6500-2 40-41

Electrical testers

Fluke T5-1000, T5-600 42
Fluke 2AC, 1AC-II, 1LAC-II, LVD2, LVD1 43
Fluke 2AC, 1AC-II, 1LAC-II, LVD2, LVD1 43
Fluke T90, T110, T130, T150 44

Phase Rotation Indicators

Fluke 9040/9062 45

Cable Locators

Fluke 2042, 2042T 46

Indoor air quality tools

Fluke 971, 985 47
Fluke 975V, 975 48
Fluke 922, 922/Kit 48
Fluke RLD2 48
Fluke CO-205, CO-220 48

Fluorescent light tester

Fluke 1000FLT 49

Insulation testers

Fluke 1587 FC, 1577 50
Fluke 1507, 1503 51
Fluke 1555, 1550C, 1555 KIT, 1550C KIT 52

Power quality analyzers

Selection guide 53
Fluke 438-II, 437-II, 435-II, 434-II 54
Fluke 1730 54
Fluke 1736, 1738 55
Fluke 345, 43B, VR1710 56
Norma 4000, 5000 57
Fluke 1745, 1744, 1743 57
Fluke 1750, 1760 58

Battery analyzers

Fluke BT521, BT520, BT510 59

Process calibration tools

Selection guide 60
Fluke 771, 772, 773 61
Fluke 789, 787 62
Fluke 715, 707, 705 63
Fluke 754, 753 64
Fluke 709, 709H 64
Fluke 726, 725 65
Fluke 724, 712B, 714B 66
Fluke 719, 719PRO 67
Fluke 718 67
Fluke 717 67
Fluke 750P 67
Fluke 721 68
Fluke 700G, 700RG Series 68

Intrinsically safe products

Fluke 28 II Ex 69
Fluke 707 Ex 69
Fluke 718 Ex 69
Fluke 721 Ex 69
Fluke 725 Ex 69
Fluke 700P Ex 69
Fluke 568 Ex 69
700G Series Pressure Gauges 69
1551A EX, 1552A Ex "Stik" Thermometers 69

ScopeMeter® test tools

Selection guide 70
Fluke 125/B, 124/B, 123/B 71
Fluke 190-502 72
Fluke 190-104 72
Fluke 190-202 72
Fluke 190-102 72
Fluke 190-062 72
Fluke 190-504 73

Infrared tools

Selection guide 74-75

Fluke Expert Series

Fluke TiX560/520/500 76

Fluke Professional Series

Fluke Ti450/400/300 77
Fluke Smartview Software 77

Fluke Performance Series

Fluke TiS75/65/60/55/50/45/40 78
Fluke TiS45/40, TiS20, TiS10 78

Fluke Visual IR-Thermometers and IR-Windows

Fluke VT04/VT04A 79
Fluke CV400/401/300/301/200 79
Fluke CLKT100/75/50 79
Fluke 62 Max+, 62 Max, 59 Max, 572-2 80
Fluke 54-2-B, 53-2-B, 52-2, 51-2 80
Fluke 568, 566, 561, 61, 63 81

Alignment tools

Fluke 830 82

Stroboscopes

Fluke 820-2 83

Vibration

Fluke 810 84
Fluke 805 FC 85

Accessories

Cases and holsters 86-88
Sets and kits 89
Test leads, probes and clips 90-91
Fluke SureGrip™ accessories 92-93
Fluke temperature accessories 94-95
Fluke current clamps 96-97
Fluke lights and hangers 98
Specialty accessories and software 99

Safety 100-101
Fuse and warranty info 102
After sales service 103



John M. Fluke, Sr.

Aerial photo of Fluke Park,
Everett, WA



What is Fluke?

Fluke Corporation is the world leader in the manufacture, distribution and service of electronic test tools and software. Sales and service subsidiaries are located in Europe, North America, South America, Asia and Australia. Fluke Corporation has authorized distributor and manufacturer representative channels in more than 100 countries and employs approximately 2,400 people.

From industrial electronic installation, maintenance and service, to precision measurement and quality control, Fluke tools help keep business and industry around the globe up and running.

“ We must always recognize the customer is our boss. We exist to serve their needs and they have the right to a little more than they thought they paid for.”

John M. Fluke, Sr.

Why choose Fluke?

With more than 60 years of innovation, Fluke tools are designed with you in mind.

- Fluke tools are known for portability, ruggedness, safety ease of use, accuracy and rigid standards of quality.
- Our after-service team offers a range of capabilities beyond repairing and calibrating your instrument.
- We help you keep up on the latest technologies and safety standards with hands-on seminars, online trainings and quick reads.
- Over 40 of our tools now use the Fluke Connect® app and online dashboard to help you save and share data, act on events, and increase workplace safety.

Our core values:

- Customers talk, we listen
- Results matter
- Innovation: defines our future
- Continuous improvement is our way of life
- The best team wins
- Our customer has the right to get a little bit more than they paid for

Going green – minimizing our environmental impact

To reduce our carbon footprint, Fluke is eliminating paper manuals, inserts and software CDs in product shipments. We are “Going Green” on more products every day.



Join us in helping the environment by choosing paperless options. If you want a hard copy, we will help you download one online or deliver one at no cost—anywhere in the world.

Winning tools



Fluke Connect® Assets



Fluke Connect® Assets

Winner
Fluke Connect® Assets
Apps for Engineers category
2015 Product of the Year
Plant Engineering



TiX560 Infrared Camera

Winner
TiX560 Infrared Camera
#1 Infrared Imaging/Thermography
Reader's Choice Awards
Control



902 FC True-rms Wireless
HVAC Clamp Meter

Expert resources and advice

You can depend on Fluke for the information you need to help you on the job—and, it's all formatted for your smart phone. Besides in-depth product information and specifications, learn best practices for using Fluke tools, watch expert how-to videos, register for webinars and more.

Seminars and training program

If you want in-depth information sign up for one of our seminars and learn about managing your processes efficiently and reducing energy costs in your facility.

- Energy measurement principles
- Motors and drives troubleshooting
- Theory and practice of process calibration
- Power quality seminars
- Thermography seminars

Visit your local Fluke website for more information.

Applications/videos

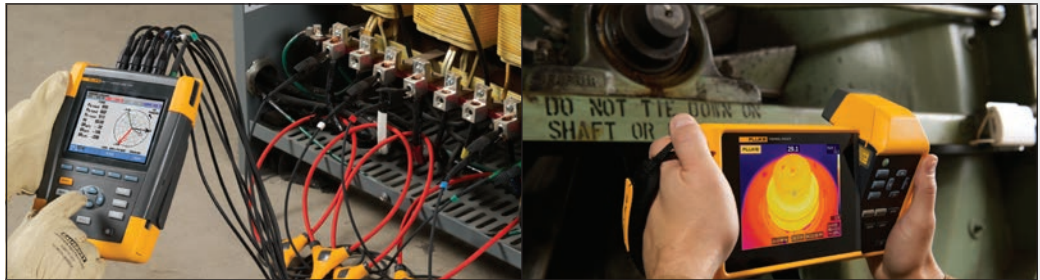

Online fundamentals

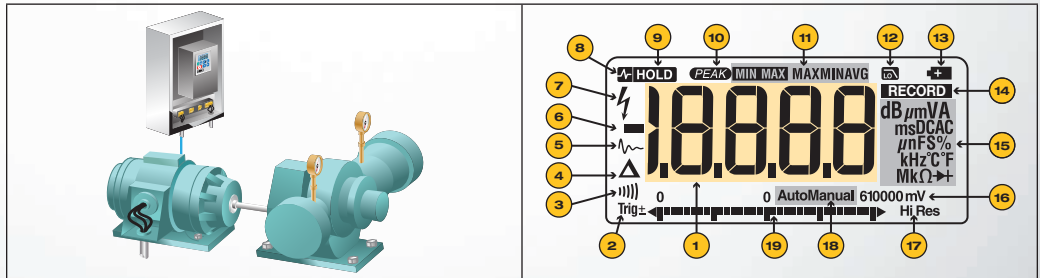

Online training



NEW PRODUCTS



Instantly trend and monitor intermittent problems with TrendIt™ graphs.

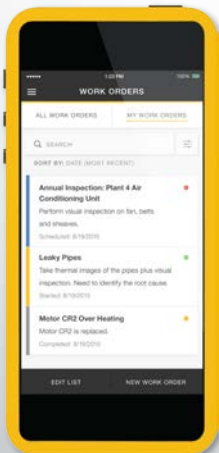

Wirelessly save measurements directly from your test tools into work orders—only available with Fluke Connect®

Fluke Connect

An integrated system of wireless test tools and asset management software.

Preventive maintenance simplified. Rework eliminated.

Save time and improve the reliability of your maintenance data by wirelessly syncing measurements using the Fluke Connect® system.

- Eliminate data-entry errors by saving measurement data directly from the tool and associating it with the work order, report or asset record
- Maximize uptime and make confident maintenance decisions with data you can trust and trace
- Access baseline, historical and current measurements by asset
- Move away from clipboards, notebooks and multiple spreadsheets with a wireless one-step measurement transfer
- Share your measurement data using ShareLive™ video calls and emails

Fluke Connect enabled products include:

- Current meters
- Digital multimeters
- Installation testers
- Portable oscilloscopes
- Temperature meters
- Voltage meters
- Vibration meters
- Process tools
- Infrared cameras



WiFi or cellular service is required to share data. Smart phone, wireless service and data plan not included with purchase. First 5 GB of storage is free.

Free Trial Terms: Open to those 18 years or older (or the age of majority under applicable law, whichever is older). Free trial is for a limited duration and is offered for a limited time. Void where prohibited by law. Terms and conditions are available upon registration.

Screens adjusted slightly to accommodate print. Smartphone is not included with purchase.

Within your provider's wireless service area and subject to your plan's pricing and other terms. Fluke Connect is not available in all countries. Some Fluke Connect features require a subscription subject to payment terms and may not be available in all countries.



NEW PRODUCTS



Fluke 279 FC True-rms Thermal Multimeter

Find. Repair. Validate. Report.

The 279 FC is a full-featured digital multimeter with integrated thermal imaging and is designed to increase your productivity and confidence. The thermal multimeter helps you find, repair, validate and report many electrical issues quickly so that you are confident problems are solved.

Locate the problem immediately

Thermal imaging multimeters are a first-line troubleshooting tool for electrical equipment that can check hot spots on high-voltage equipment and transformers, detect heating of fuses, wires, insulators, connectors, splices and switches. Scanning with the 279 FC's thermal imager reveals many electrical issues rapidly and from a safe distance. By combining two tools into one, the thermal multimeter lightens the load and increases productivity.

Expanded functionality

Compatible with iFlex® (a flexible current clamp) to expand your measurement capabilities and get into tight, hard to reach spaces for current measurement (up to 2500 A ac). The large full-color LCD screen makes for easier and clearer viewing of images and readings. The 10 hour+ rechargeable battery keeps you going all day long under normal conditions.

Communicate your results

With built-in Fluke Connect®, transmit wirelessly to a smartphone and save time on reporting to validate work is complete. Troubleshoot better by instantly trending and monitoring measurements live on your smartphone screen. Create and email reports right from the field.



Fluke 279 FC
Thermal Multimeter



With built-in Fluke Connect, transmit results wirelessly to a smartphone and save time on reporting to validate work is complete.

Quickly find, repair, validate and report many electrical issues.

Specifications

DMM	
Voltage ac/dc	1000 V
Current ac	2500 A ac (with iFlex Flexible Current probe)
Resistance	50 M Ω
Frequency	100 kHz
Capacitance	9,999 μ F
Continuity/Diode test/ Min Max/Display hold	•
Infrared camera	
Resolution	80 x 60
Temperature range	-10 °C to 200 °C (14 °F to 392 °F)
Other	
Safety rating	CAT III 1000 V, CAT IV 600 V
Warranty	Three year

Ordering information

Models	Included accessories
FLK-279 FC TRMS Thermal Multimeter	TL75 test leads, rechargeable lithium ion battery and charger
FLK-279 FC/iFlex TRMS Thermal Multimeter	18-inch (45.72 cm) iFlex flexible current probe, TL175 test leads, rechargeable lithium ion battery, charger, hanging strap and soft carrying case



Fluke 376 FC True-rms Wireless AC/DC Clamp Meter



Expand your measurement range with increased flexibility

The Fluke 376 FC offers advanced troubleshooting performance. The iFlex® flexible current probe allows for easy measurement around wires in tight spaces. In addition, the Fluke 376 FC is now part of the Fluke Connect® family of wireless test tools. Now you can:

- Troubleshoot faster: Instantly log, trend, and monitor intermittent problems with a 65,000 measurement internal memory and Trendit graphs
- Work safer: Connect your meter to your phone through Bluetooth, clamp your meter around a conductor and walk up to 30 m (98 ft) away from the point of measurement
- Save time reporting: Easily create reports by capturing measurements from your meter and email them right from the field
- Innovative flexible current probe: Measure around cumbersome conductors and improve wire access in tight spaces
- Share from anywhere: Stay on the same page when you and your team are in different places with Sharelive™ videocall



Specifications

Functions	Range and resolution
Safety rating	CAT III 1000 V, CAT IV 600 V
A ac range	999.9 A with clamp jaws, 2500 A with iFlex® flexible current clamp
A dc range	999.9 A
Best resolution	0.1 A
V ac range	1000 V
V dc range	1000 V
mV dc range	500 mV
Ohms range	60.00 kΩ
Frequency	5 - 500.0 Hz
Capacitance	1 μF - 1,000 μF
Auto shutoff	•
True rms	•
Display hold	•
Inrush measurements	•
Backlight	•
DC Zero	•
Min/Max	•
Fluke Connect® compatible	•
VFD low-pass filter	•
Logging	•
iFlex® flexible current clamp	Included

Ordering information

Models	Included accessories
FLUKE-376 FC, Wireless True-rms AC/DC Clamp meter with iFlex	18-inch (45.72 cm) iFlex flexible current probe, test leads, TPAK magnetic hanging strap, soft carrying case, instruction card, safety information sheet, two AA alkaline batteries



NEW PRODUCTS



Fluke 902 FC True-rms HVAC Clamp Meter

Improve productivity in the field

The Fluke 902 FC delivers the features necessary to diagnose and repair HVAC systems. Additionally, with Fluke Connect® you can trend measurements, create and send reports right from the field, safely stay away from live equipment.

Applications for HVAC

- 600 A ac current measurement
- 600 V ac and dc voltage measurement
- Temperature measurement from -10 °C to 400 °C (14 °F to 752 °F)
- 1000 µF capacitance measurement
- DC current measurement to 200 µA
- True-rms voltage and current for accurate measurements on non-linear signals
- Resistance measurement to 60 kΩ
- Min and max recording to capture variations automatically

Applications for HVAC

- Get more done faster and safer with Fluke Connect by capturing measurements wirelessly. Save your measurement to Fluke Cloud™ storage for further analysis
- Read measurements on your phone at a safe distance
- Instantly trend and monitor measurements live on your phone screen
- Ergonomic design fits in your hand and can be used while wearing PPE gear
- Three-year warranty



Specifications

General specifications		
A ac (via Jaw)	Range	60.00/600.0 A
	Resolution	0.01/ 0.1A
	Accuracy	2.0 % ± 5 digit (45-65 Hz) 2.5 % ± 5 digit (65-400 Hz)
	Crest Factor (50 Hz or 60 Hz)	2.5 MIN @ 220 A 3.0 MIN @ 180 A > 1.4 MIN @ 600 A Add 2 % for CF > 400A
V ac	Resolution	0.1 V
	Accuracy (45-400 Hz)	1.5% ± 5 digits
	Range	600.0 V
V dc	Resolution	0.1 V
	Accuracy	1 % ± 5 digits
	Range	600.0 V
Ohms	Resolution	0.1/1/10
	Accuracy	1 % ± 5 digits
	Range	600/6000/60.00kΩ
Capacitance	Resolution	0.1/1 µF
	Accuracy	1 % ± 4 digits
	Range	100.0/1000 µF
µA	Resolution	0.1 µA
	Accuracy	1% ± 5 digits
	Range	200 µA
Contact temperature	Resolution	0.1 C/F
	Accuracy	1 % ± 8 digits
	Range	-10 °C to 400 °C (14 °F to 752 °F)
Continuity beeper	Beeper volume	75 dBA nom. 15 cm. from case front
	On thresh	<= 30 Ω

Ordering information

Models	Included accessories
FLK-902 FC HVAC Clamp Meter	TL75 test leads, 80BK integrated DMM temperature probe, 2 AA alkaline batteries, soft carrying case, users' manual, Statement of Calibration

NEW PRODUCTS

Fluke 438-II Power Quality and Motor Analyzer



Quickly and easily discover electrical and mechanical performance of electric motors, and evaluate power quality with a single test tool

The new Fluke 438-II Power Quality and Motor Analyzer adds key mechanical measurement capabilities for electric motors to the advanced power quality analysis functions of the Fluke 430 Series II Power Quality Analyzers. Quickly and easily measure and analyze key electrical and mechanical performance parameters such as power, harmonics, unbalance, motor speed, torque and mechanical power without the need of mechanical sensors.



- Measure key parameters on direct-on-line motors including torque, RPM, mechanical power and motor efficiency
- Perform dynamic motor analysis by plotting of motor de-rating factor against load according to NEMA guidelines
- Calculate mechanical power and efficiency without the need of mechanical sensors, just connect to the input conductors and you're ready to go
- Measure electrical power parameters such as voltage, current, power, apparent power, power factor, harmonic distortion and unbalance to identify characteristics that impact motor efficiency
- Identify power quality issues such as dips, swells, transients, harmonics and unbalance
- PowerWave data technology captures fast RMS data, and shows half-cycle averages and waveforms to characterize electrical system dynamics (generator start-ups, UPS switching etc)
- Waveform capture function captures 100/120 cycles (50/60 Hz) of each event detected event, in all modes, without set-up
- Automatic transient mode captures waveform data at 200 kS/s on all phases simultaneously up to 6 kV
- Fluke Connect® Compatible* View data locally on the instrument, via Fluke Connect mobile app and PowerLog 430-II desktop software

Specifications

Motor measurement	Range	Resolution	Resolution	Default limit
Mechanical motor power	0.7 kW to 746 kW 1 hp to 1000 hp	0.1 kW 0.1 hp	± 3 % ¹ ± 3 % ¹	100 % = rated power 100 % = rated power
Torque	0 Nm to 10 000 Nm 0 lb ft to 10 000 lb ft	0.1 Nm 0.1 lb ft	± 5 % ¹ ± 5 % ¹	100 % = rated torque 100 % = rated torque
rpm	0 rpm to 3600 rpm	1 rpm	± 3 % ¹	100 % = rated rpm
Efficiency	0 % to 100 %	0.10 %	± 3 % ¹	NA
Unbalance (NEMA)	0 % to 100 %	0.10 %	± 0.15 %	5%
Harmonics voltage factor (NEMA)	0 to 0.20	0.1	± 1.5 %	0.15
Unbalance derating factor	0.7 to 1.0	0.1	indicative	NA
Harmonics derating factor	0.7 to 1.0	0.1	indicative	NA
Total NEMA derating factor	0.5 to 1.0	0.1	indicative	NA

Ordering information

Models	Included accessories
FLUKE-438-II Three-Phase Power Quality and Motor Analyzer	Test lead set, i430 thin flexible current probes (4), battery, power adapter, combination WiFi/SD card*, Soft carry case, CD Rom with PowerLog 430-II software and user documentation
FLUKE-430-II/MA	Upgrade option for 434-II, 435-II, and 437-II Power Quality Analyzers with firmware license code

* Not all models are available in all countries. Check with your local Fluke representative.



NEW PRODUCTS



Fluke 1660 Series Multifunction Installation Testers

Installation Testers: A Multifunction Tester that Offers Great Versatility

The new Fluke 1660 Series Installation Testers are the only installation testers that help prevent damage to connected appliances and also allow users to send test results wirelessly via smartphone directly from the field.

Fluke Connect® compatible (1664 FC only)

View test results on your smartphone via Fluke Connect® mobile app and Data Management Software (Fluke DMS, sold separately). Download the free Fluke Connect app to enable wireless data transmission and Fluke Cloud™ storage.

Insulation pretest (1664 FC only)

The new Fluke 1660 Series Installation Testers are the only installation testers that help prevent damage to connected appliances.

Auto test sequence (1664 FC only)

Start a sequence of seven critical tests with one press of the TEST button.

Product highlights

- Heavy duty, single input line cord, guards against failures in the field
- Z Max memory function for loop/line test
- Three-year standard warranty
- Safety rating (IEC/EN 61010): CAT III 500 V, CAT IV 300 V

Key product capabilities

The 1660 Series testers verify the safety of electrical installations in domestic, commercial and industrial applications. They can ensure that fixed wiring is safe and correctly installed to meet the requirements of IEC 60364-6 and all relevant local standards.

Fluke 1664 FC

The Fluke 1664 FC is the only installation tester that protects connected appliances from damage during insulation tests, and allows you to share your test results wirelessly by smartphone with coworkers or customers. Fluke's patent pending Insulation PreTest stops you from performing tests with appliances that are connected to the system during test. This helps eliminate accidental damage and keeps your customers happy.

In addition, the Fluke 1664 FC offers you the power of Fluke Connect. Now you can send test results straight from your Fluke 1664 FC to your smartphone, and transmit those results to other members of your team. You can get feedback, suggestions and even have work orders sent to your job site. You can also save your test results to Fluke Cloud™ storage. No more writing down data on paper with the possibility of transcription errors. Cloud storage gives you a fast, secure and accurate way to storing all your test data and create test certificates with Fluke DMS.

Fluke 1663

The ideal tester for professional trouble-shooters. This instrument is ideal for professional users—high-end functionality, advanced measurement capability, yet it is still easy to use. Operation is intuitive and easily mastered by all levels of field workers.

Fluke 1662

A solid, basic installation tester. The Fluke 1662 gives you Fluke reliability, simple operation and all the testing power you need for basic installation testing.



NEW PRODUCTS

Specifications

General specifications	
Size	10 cm (L) x 25 cm (W) x 12.5 cm (H)
Weight (incl. batteries)	approx. 1.3 kg
Battery size, quantity	1.5 V type AA (IEC LR6), 6 pcs.
Sealing	IP 40
Safety	Complies with IEC/EN61010-1, UL61010, ANSI/ISA –s82.02.01 and CAN/CSA c22.2 No. 1010)
Safety rating (IEC/EN61010)	CAT III 500 V, CAT IV 300 V
Performance	EC/EN61557-1 to IEC/EN61557-7 and IEC/EN61557-10

Selection guide

	1664 FC	1663	1662
Insulation-PreTest™ safety function	•		
Insulation at L-N, L-PE, N-PE inputs	•		
Auto Test sequence	•		
Loop and line resistance—mΩ resolution	•		
Continuity at L-N, L-PE, N-PE inputs	•	•	
Test smooth dc sensitive RCDs (Type B/B+)	•	•	
Earth resistance	•	•	
Voltage trms (ac and dc) and frequency	•	•	•
Wiring polarity checker, detects broken PE and N wires	•	•	•
Insulation resistance	•	•	•
Continuity and resistance	•	•	•
Measure motor windings with continuity test (@ 10 mA)	•	•	•
Loop and line resistance	•	•	•
Prospective Earth Fault Current (PEFC/IK)	•	•	•
Prospective Short-Circuit Current (PSC/IK)	•	•	•
RCD trip time	•	•	•
RCD trip current (ramp test)	•	•	•
Measures trip time and current for RCD type A and AC in one test	•	•	•
RCD variable test current	•	•	•
Automatic RCD test sequence	•	•	•
Phase sequence test	•	•	•
Z Max Memory	•	•	
Memory	•	•	•
IR-USB and BLE interface (when used with optional Fluke DMS and FVF software)	IR-USB/ BLE	IR-USB	IR-USB

Ordering information

Models	Included accessories
FLK-1664 FC Multifunction Installation Tester	6x AA (IEC LR6) cell batteries, C1600 hard carrying case, zero adapter, heavy duty mains cord, STD standard test lead set, padded carrying and waist strap, quick reference guide, TP165X remote control probe and lead set (FTP/UK fused probes, UK only), user's manual on CD
FLK-1663 Multifunction Installation Tester	
FLK-1662 Multifunction Installation Tester	



NEW PRODUCTS

Fluke Connect® compatibility guide

The Fluke Connect app displays readings from up to 10 modules on the iPhone and six modules on an Android phone. The TiX560, TiX520, TiX500, Ti450, Ti400, Ti300, TiS75, TiS65, TiS60, TiS55, TiS50, TiS45, TiS40, TiS20 and TiS10 Infrared Cameras display their own measurements plus readings from up to five wireless modules. The 3000 FC wireless digital multimeter displays its own readings plus measurements from up to three wireless modules.

	Fluke Connect App – iOS and Android™	TiX560/520/500 Thermal Imagers	Ti450/400/300 Thermal Imagers	TiSxx Series Thermal Imagers	3000 FC Digital Multimeter	a3000 FC AC Current Clamp Meter	902 FC True-rms HVAC Clamp Meter	376/375/374 FC True-rms Clamp Meters	a3001 FC iFlex® AC Current Meter	a3002 FC AC/DC Current Meter Module	a3003 FC 2000 A DC Current Clamp Meter	a3004 FC DC 4–20 mA Current Clamp Meter	v3000 FC AC Voltage Meter	v3001 FC DC Voltage Meter	t3000 FC Temperature Meter	438-II/437-II/435-II/434-II PQ Analyzers	789 ProcessMeter™	1587 Insulation Multimeter	1664 FC Installation Tester	805 FC Vibration Tester	125B/124B/123B ScopeMeters®	279 FC Thermal Multimeter	ir3000 FC Wireless Connector
Fluke Connect App – iOS and Android™	•	•	•	•	•	•	•	•	•	•	•	•	•	•	•	•	•	•	•	•	•	•	•
TiX560/520/500 Thermal Imagers	•				•	•			•	•	•	•	•	•	•								
Ti450/400/300/200 Thermal Imagers	•				•	•			•	•	•	•	•	•	•								
TiS75/65/60/55/50/45/40/20/10 Thermal Imagers	•				•	•			•	•	•	•	•	•	•								
3000 FC Digital Multimeter	•	•	•			•			•	•	•	•	•	•	•								
a3000 FC AC Current Clamp Meter	•	•	•		•																		
902 FC True-rms HVAC Clamp Meter	•																						
376/375/374 FC True-rms Clamp Meters	•																						
a3001 FC iFlex® AC Current Meter	•	•	•		•																		
a3002 FC AC/DC Current Meter Module	•	•	•		•																		
a3003 FC 2000 A DC Current Clamp Meter	•	•	•		•																		
a3004 FC 4–20 mA DC Current Meter	•	•	•		•																		
v3000 FC AC Voltage Meter	•	•	•		•																		
v3001 FC DC Voltage Meter	•	•	•		•																		
t3000 FC Temperature Meter	•	•	•		•																		
438-II/437-II/435-II/434-II Power Quality Analyzers	•																						
789 ProcessMeter™	•																						
1587 Insulation Multimeter	•																						
1664 FC Installation Tester	•																						
805 FC Vibration Tester	•																						
125B/124B/123B ScopeMeters®	•																						
279 FC Thermal Multimeter	•																						
ir3000 FC Wireless Connector	•	Connect adapter to: Fluke 789, 289, 287																					

Fluke Connect® not available in all countries

NEW PRODUCTS

Wireless Fluke Connect® tools

Ordering information

Kits	Included
FLK-3000FC Industrial System	Wireless multimeter, 3 wireless iFlex current meters, 3 wireless ac voltage meters, 4 hanging straps with magnets, 2 test leads with clips, USB, CD, info pack, and soft case
FLK-3000FC GM, General Maintenance System	Wireless multimeter, wireless iFlex ac current meter, wireless ac voltage meter, wireless dc voltage meter, 3 test leads, alligator clips, and 3 magnetic hanging straps
FLK-3000FC HVAC System	Wireless multimeter, wireless ac current clamp meter, wireless temperature meter, test leads, alligator clips, K-type thermocouple, and magnetic hanging strap
FLK-Ti400 60HZ/FCA iFlex® Kit	Infrared camera, ac power supply and battery pack charger (including mains adapters), 2 lithium ion smart battery packs, micro SD memory card, USB cable, HDMI video cable, hard carrying case, soft transport bag, adjustable hand strap, international adapter set (9 Hz only), wireless multimeter, wireless iFlex A AC current module, test leads, alligator clips, flexible current probe, magnetic hanging strap, and soft case
FLK-Ti400 9HZ/FCA iFlex Kit	Infrared camera, ac power supply and battery pack charger (including mains adapters), 2 lithium ion smart battery packs, micro SD memory card, USB cable, HDMI video cable, hard carrying case, soft transport bag, adjustable hand strap, international adapter set (9 Hz only), wireless multimeter, wireless iFlex A AC current module, test leads, alligator clips, flexible current probe, magnetic hanging strap, and soft case
FLK-A3000FC Kit, Wireless AC Current Clamp Kit	Wireless multimeter, wireless ac current clamp meter, test leads, alligator clips, and magnetic hanging strap
FLK-A3001FC Kit, Wireless iFlex® AC Current Clamp Kit	Wireless multimeter, wireless iFlex ac current meter, test leads, alligator clips, magnetic hanging strap
FLK-V3000FC Kit, Wireless AC Voltage Kit	Wireless multimeter, wireless ac voltage meter, 2 test leads, 2 alligator clips, and magnetic hanging strap
FLK-V3001FC Kit, Wireless DC Voltage Kit	Wireless multimeter, wireless dc voltage meter, 2 test leads, 2 alligator clips, and magnetic hanging strap
FLK-V3003FC Kit, Wireless AC/DC Voltage Measurement Kit	Wireless multimeter, ac voltage meter, dc voltage meter, hanging strap with magnets, 3 test leads, 4 alligator clips, info pack, and soft case

Fluke Connect® not available in all countries

Kits—buy more, save more

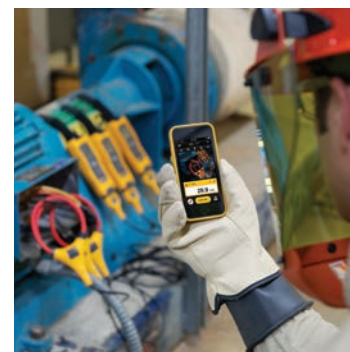

NEW PRODUCTS



Fluke Infrared Cameras

Expert Series: TiX500

Tablet-sized screen. More details. Faster decisions.

See more details on the tablet-sized 5.7 inch screen, so you can easily make decisions in the field. Get maximum ergonomics and easily maneuver over, under and around targets with the 240° rotating lens. Go from being completely out-of-focus to clear accurate and in focus with MultiSharp™ Focus which captures multiple images and combines them to create one in focus image. Get instant focus with laser driven target detection only with LaserSharp® Auto Focus.

Make decisions in the field.

- See small details in the image and discover anomalies faster on the 5.7 inch tablet sized touchscreen—the largest in its class
- Edit and analyze images on camera—edit emissivity, enable color alarms and markers, and adjust IR-Fusion® visual and infrared image blending
- Wirelessly sync images directly from your camera to the Fluke Connect® app on your smartphone, and attach to an asset record or work order.

Inspect hard to reach targets.

- Easily maneuver over, under and around objects with the 240° rotating lens while viewing the screen at a comfortable angle
- See the details you need from far away, with interchangeable smart lenses—2x and 4x telephoto, wide angle, and 25 micron macro—no calibration required

Focus near and far in a single image.

- Capture a clear, accurate image focused throughout the field of view with MultiSharp™ Focus. Simply point and shoot—the camera automatically processes a stack of images focused near and far
- Get an instant in-focus image of your target. LaserSharp® Auto Focus uses a built-in laser distance meter that calculates and displays the distance from your designated target with pinpoint accuracy

Professional Series: Ti450

100% focused –every object, near and far

The Fluke Ti450 Infrared Camera with MultiSharp Focus delivers images focused throughout the camera's field of view, get 4x's the pixel data with SuperResolution, and wirelessly sync images from the camera to the cloud for attachment to assets or work orders.

- Capture a clear, accurate image focused throughout the field of view with MultiSharp Focus. Simply point and shoot—the camera automatically processes a stack of images focused near and far
- Get an instant in-focus image of your designated target. LaserSharp® Auto Focus, exclusive to Fluke, uses a built-in laser distance meter that calculates and displays the distance from your designated target with pinpoint accuracy
- Get 4x the pixels with SuperResolution to create a 640 x 480 image
- Save time—wirelessly sync images directly from your camera to the Fluke Connect system, and attach to an asset record or work order
- Get the context of the visual and infrared details all in one precisely blended or picture-in-picture image with IR-Fusion® technology
- Monitor processes with video recording, video streaming, and remote control
- See the details you need with interchangeable smart lenses—2x and 4x telephoto and wide angle—no calibration required



Get tough shots from any angle with a 240° degree rotating lens and the only 5.7 inch LCD in its class.



MultiSharp™ Focus produces an image focused throughout the field of view.

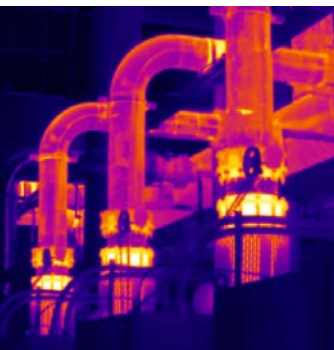

Fluke Infrared Cameras

Performance Series: TiS75

High performance manual focus 320 x 240 infrared camera

Professional quality images with features that help you easily and quickly both see and solve the problem.

- Quality 320 x 240 images with manual focus, get crisp images from as close as 0.15 m (6 in)
- See the location of the issue with blended IR and visual light images with 5MP visual light camera—patented IR-Fusion® technology
- Make decisions in real time – wirelessly sync images from your camera, create and email reports all with your smart phone and the Fluke Connect® app.
- Wirelessly connect to other Fluke Connect tools¹
- Removable 4GB micro SD card
- Voice annotation
- Smart battery with LED charge indicator



Specifications

	TiX500	Ti450	TiS75
Detector resolution	320 x 240 640 x 480 Super Resolution mode		320 x 240
I FOV (spatial resolution)	1.31 mRad		2.0 mRad
Field of view	24 °H x 17 °V		35.7 °H x 26.8 °V
Focus system	MultiSharp™ Focus, LaserSharp® Auto Focus with built-in laser distance meter and advanced manual focus		Manual focus
Wireless connectivity	Fluke Connect app compatible		
IR-Fusion technology	Yes, blended visual and infrared images		
Display	5.7 inch touchscreen LCD	3.5 inch touchscreen LCD	3.5 inch LCD
Design	Ergonomic FlexCam design with a 240 degree rotating lens	Rugged, ergonomic design for one-handed use	Rugged, lightweight, ergonomic design for one-handed use
Temperature measurement range	-20 °C to +650 °C (-4 °F to +1202 °F) ≤ 0.05 °C at 30 °C target temp (50 mK)	-20 °C to +1200 °C (-4 °F to +2192 °F) ≤ 0.05 °C at 30 °C target temp (50 mK) Filter Mode: ≤ 0.03 °C at 30 °C target temp (30mK)	-20 °C to +550 °C (-4 °F to +1022 °F)
Thermal sensitivity			≤ 0.08 °C at 30 °C target temp (80 mK)

Ordering information

Models	Included accessories
FLK-TiX500 9 Hz Infrared Camera; 320 x 240	AC power supply, battery pack charger (including universal ac adapters), two rugged lithium ion smart battery pack, USB cable, HDMI video cable; micro SD card, rugged, hard carrying case, adjustable neck and hand straps, and Bluetooth headset (where available)
FLK-TiX500 60 Hz Infrared Camera; 320 x 240	
FLK-Ti450 9 Hz Infrared Camera; 320 x 240	AC power supply, battery pack charger (including universal ac adapters), two rugged lithium ion smart battery packs, USB cable, HDMI video cable, 4GB micro SD card, rugged, hard carrying case, soft transport bag, and adjustable hand strap
FLK-Ti450 60 Hz Infrared Camera; 320 x 240	
FLK-TiS75 9 Hz Infrared Camera; 320 x 240	AC power supply, battery pack charger (including universal ac adapters), two rugged lithium ion smart battery packs, USB cable, micro SD card, rugged, hard carrying case, soft transport bag, and adjustable hand strap
FLK-TiS75 30 Hz Infrared Camera; 320 x 240	

¹Fluke Connect® not available in all countries



Frontline troubleshooting at 320 x 240 resolution.

Wirelessly sync images directly from your camera to the Fluke Connect® system with your smartphone



NEW PRODUCTS



Fluke 154 HART Calibration Assistant

**HART Calibration assistance at your fingertips.
Combine with a Fluke calibrator for a total HART calibration solution.**

The Fluke 154 is a standalone tablet based HART® communication tool. The tablet configured with the “Fluke HART” mobile app utilizes a wireless HART modem that connects directly to the HART transmitter being tested or configured. When you combine your Fluke 154 HART Calibration Assistant with a Fluke 750 Series Documenting Process Calibrator, or a 720 Series Multifunction Process Calibrator you have a complete HART calibration and configuration solution.

The 154 puts HART device configuration at your fingertips. An Android™-based tablet user interface makes HART configuration easy. The external wireless modem allows you to connect the modem to the transmitter being tested so you can communicate to the device remotely. HART transmitters can often be found in confined spaces that are difficult to access, or are out of reach. The Fluke 154 helps reduce the need to stand right next to the device being tested or configured so you can work from a safer, more convenient location.

Fluke 154 features:

- Full HART Device Description (DD) of all HART devices
- Configure HART devices
- Perform HART trim on HART devices when used with a Fluke 750, or 720 series calibrator
- Monitor device PV, SV, TV, QV and other measured HART variables
- Quarterly HART DD updates for free
- Convenient wireless connectivity to HART modem
- Easy to use, fast connect and view HART data
- Store HART device configurations
- Long range wireless communication up to 76.2 m (250 ft)

Multiple language support:

Select language from the Android operating system. Hart communication commands are limited to English per the HART device descriptions.

Wireless HART Modem:

Includes configurable connection cable that accepts either the hook clips for connecting to wires or the extended tooth alligator clips designed to connect to transmitter connection screw heads. Rechargeable lithium-ion battery lasts easily for several days of HART device configuration and testing activities. Rugged enclosure and test lead set designed for process environments

Store device configurations:

Store HART device configurations in ASCII or PDF file configurations.

HART support:

Complete access to all features of the HART device’s DD including methods. Meets HART physical layer specification: HCF_SPEC-54

DD updates:

Download free DD updates from Fluke for 3 years. Updates available when DD updates released from the HART FieldComm group (approximately four times a year).

Hard side case:

Protects and stores tablet, modem, test leads and connection cable in a lightweight durable tote that is easy to carry.

Ordering information

Models	Included
FLK-154 HART Calibration Assistant	Tablet, tablet charger and USB, micro-cable, Fluke HART App. (installed), HART modem, USB mini-cable, proof of purchase for product activation, hook test clips, alligator clips, magnetic hanging strap, case, manual installed on tablet, and three-year warranty



NEW PRODUCTS

Fluke PRV240 Proving Unit

Unique, compact, convenient

The Fluke PRV240 Proving Unit is a portable, pocket-sized, battery-powered voltage source. It is unique in that it sources stable ac and dc voltages for both LoZ and HiZ instruments.

Designed for safety and compliance

The Fluke PRV240 provides a safe method to verify that your electrical test tool is operating properly before you conduct any live tests. The concept of “Test Before Touch” (TBT) involves testing your meter against a known live source before and after the actual measurement. This sequence verifies that your test tool is operating properly during the actual measurement.

Verify your test tool without unnecessary exposure to shock and arc flash. Using the PRV240 reduces the need for personal protective equipment (PPE) when a known voltage source is not available for verification of your tester or multimeter before test before TBT are performed. PPE is still needed for absence of voltage testing when appropriate.

Key benefits

- Using the PRV240 reduces the risk of shock and arc flash by validating the functionality of test tools without placing yourself in a potentially hazardous electrical environment
- Sources both ac and dc steady-state voltage—supplies 240 V dc/ac
- A single LED indicates functionality, making this unit a simple-to-use solution for complying with TBT verification of your test tool
- Compatible with both high impedance or low impedance multimeters, clamp meters or two pole testers
- Voltage is sourced through recessed contacts that are activated when tested probes are inserted to avoid accidental contact
- Includes TPak™ Magnetic Hanging Strap
- Long battery life—5,000 tests per set of four AA batteries



Specifications

General specifications		
Output voltage	240 V ac rms or dc	± 10 % ≥ 1 MΩ
	LoZ >3 kΩ load	60 V ac typical 50 V ac rms minimum
LED power indicator	Turns on when output voltage is present	
Battery	4 AA Alkaline batteries NEDA, 24 A IEC LR03	
Battery life	5000 (5-second duration) test cycles with >1 MΩ load, 300 tests minimum with > 3 kΩ load	
Operating temperature	-10 °C to +50 °C (32 °F to 95 °F)	
Operating humidity	0 % to 90 % (0 °C to 35 °C)	0 % to 70 % (35 °C to 55 °C, 95 °F to 131 °F)
	Operating altitude	2000 m
Dimensions	11.7 cm x 7.4 cm x 2.8 cm (4.6 in x 2.9 in x 1.1 in), Pollution Degree 2	
Weight	0.23 kg (8 oz) includes batteries	
Safety	EN 61010-1, EN 61010-2-030	
Warranty	One-year	
Electromagnetic Compatibility (EMC)	EN 61326-1	Portable EM environment; CISPR 11, Group 1, Class A
	US (FCC)	47 CFR 15 subpart B, this product is considered an exempt device per clause 15.103
	Korea (KCC)	Class A Equipment (Industrial Broadcasting & Communication Equipment)
	This product meets requirements for industrial (Class A) electromagnetic wave equipment and the seller or user should take notice of it. This equipment is intended for use in business environments and not to be used in homes.	

Ordering information

Models	Included accessories
PRV240 Proving Unit	TPAK hanging strap, four AA batteries, instruction sheet



Digital multimeter selection guide

Models	Advanced meters			Wireless meters		General purpose
	87 V	289	287	233	3000 FC	179
Basic features						
Counts	20000	50000	50000	6000	6000	6000
True-rms readings	ac	ac+dc	ac+dc	ac	ac	ac
Basic dc accuracy	0.05 %	0.025 %	0.025 %	0.25 %	0.09 %	0.09 %
Wide bandwidth	20 kHz	100 kHz	100 kHz			
Auto/manual ranging	•/•	•/•	•/•	•/•	•/•	•/•
ATEX II 2G Eex ia IICT4 safety rating Z1/Z2						
Measurements						
Voltage ac/dc	1000 V	1000 V	1000 V	1000 V	1000 V	1000 V
Current ac/dc	10 A	10 A	10 A	10 A	400 mA	10 A
Resistance	50 MΩ	500 MΩ	500 MΩ	40 MΩ	50 MΩ	50 MΩ
Frequency	200 kHz	1 MHz	1 MHz	50 kHz	100 kHz	100 kHz
Capacitance	10,000 μF	50,000 μF	50,000 μF	10,000 μF	10,000 μF	10,000 μF
Temperature	+1090 °C	+1350 °C	+1350 °C	+400 °C		+400 °C
dB		60 dB	60 dB			
Conductance	50 nS	50 nS	50 nS			
Duty cycle/pulse width	•/-	•/•	•/•			
Continuity/diode test	•	•	•	•	•	•
Motor Drive (ASD) Measurements	•	•				
VoltAlert™, non-contact voltage detection						
VCHEK™						
LoZ: low input impedance		•				
Lo ohms		•				
Microamps	•	•	•			
Display						
Removable wireless display				•		
Remote wireless readings, connects to smart phone		(with ir3000 FC connector, sold separately)	(with ir3000 FC connector, sold separately)		(with FC app)	
Dot matrix display		•	•		•	
Dual display		•	•		•	
Analog bargraph	•	•	•			•
Backlight	Two level	Two level	Two level	•	•	•
Graphical trend display		•	•			
Diagnostics and data						
Min/Max recording with time stamp	•/-	•/•	•/•	•/-	•/-	•/-
Fast Min/Max	250 μs	250 μs	250 μs			
Display Hold/Auto (Touch) Hold	•/•	•/•	•/•	•/•	•/•	•/•
Relative reference	•	•	•			
Stand alone logging		•	•		(with FC app)	
Trend Capture		•	•		(with FC app)	
Readings memories		10,000	10,000		(with FC app)	
USB interface		•	•			
Other features						
Real time clock		•	•			
Automatic selection, ac/dc volts						
Closed case calibration	•	•	•	•	•	•
Separate battery/fuse access	•/-	•/•	•/•	•	•	•
Automatic power off	•	•	•	•	•	•
Low battery indication	•	•	•	•	•	•
Operating temperature range	-20 °C, +55 °C	-20 °C, +55 °C	-20 °C, +55 °C	-10 °C, +50 °C	-10 °C, +50 °C	-10 °C, +50 °C
Warranty and electrical safety						
Warranty (years)	Limited lifetime	Limited lifetime	Limited lifetime	3	3	Lifetime
Input alert	•	•	•			
IP Rating	IP30				IP54	
Safety rating (EN 61010) CAT III	1000 V	1000 V	1000 V	1000 V	1000 V	1000 V
Safety rating (EN 61010) CAT IV	600 V	600 V	600 V	600 V	600 V	600 V

Models	Compact meters					Specialty meters			
	117	116	115	114	113	28 II	27 II	28IIEX	279 FC
Basic features									
Counts	6000	6000	6000	6000	6000	20000	6000	20000	6000
True-rms readings	ac	ac	ac	ac	ac	ac		ac	ac
Basic dc accuracy	0.5 %	0.5 %	0.5 %	0.5 %	0.5 %	0.05 %	0.1 %	0.05 %	0.09 %
Wide bandwidth						20 kHz	30 kHz	20kHz	
Auto/manual ranging	•/•	•/•	•/•	•/•	•/•	•/•	•/•	•/•	•/•
ATEX II 2G Eex ia IICT4 safety rating Z1/Z2								•	
Measurements									
Voltage ac/dc	600 V	600 V	600 V	600 V	600 V	1000 V	1000 V	1000 V	1000 V
Current ac/dc	10 A	600 µA	10 A			10 A	10 A	10 A	2500 A AC (with iFlex)
Resistance	40 MΩ	40 MΩ	40 MΩ	40 MΩ	60 kΩ	50 MΩ	50 MΩ	50 MΩ	50 MΩ
Frequency	100 kHz	100 kHz	100 kHz			200 kHz	200 kHz	200 kHz	100 kHz
Capacitance	10,000 µF	10,000 µF	10,000 µF		10,000 µF	10,000 µF	10,000 µF	10,000 µF	10,000 µF
Temperature		+400 °C				+1090 °C		+1090 °C	Infrared camera -10 °C to +200 °C
dB									
Conductance						60 nS	60 nS	60 nS	
Duty cycle/pulse width						•/-	•/-	•/-	
Continuity/diode test	•	•	•	•	•	•	•	•	•
Motor Drive (ASD) Measurements						•		•	•
VoltAlert™, non-contact voltage detection	•								
VCHEK™					•				
LoZ: low input impedance	•	•		•	•				
Lo ohms									
Microamps		•				•	•	•	
Display									
Removable wireless display									
Remote wireless readings, connects to smart phone									(with FC app)
Dot matrix display									
Dual display									
Analog bargraph	•	•	•	•	•	•	•	•	
Backlight	•	•	•	•	•	Two level	Two level	Two level	•
Graphical trend display									
Diagnostics and data									
Min/Max recording with time stamp	•/-	•/-	•/-	•/-	•/-	•/-	•/-	•/-	•/-
Fast Min/Max						250 µs		250 µs	
Display Hold/Auto (Touch) Hold	•/-	•/-	•/-	•/-	•/-	•/•	•/•	•/•	•/•
Relative reference						•	•	•	
Stand alone logging									(with FC app)
Trend Capture									(with FC app)
Readings memories									(with FC app)
USB interface									
Other features									
Real time clock									
Automatic selection, ac/dc volts	•	•		•	•				
Closed case calibration	•	•	•	•	•	•	•	•	•
Separate battery/fuse access	•	•	•	•	•	•/•	•	•/•	•
Automatic power off	•	•	•	•	•	•	•	•	•
Low battery indication	•	•	•	•	•	•	•	•	•
Operating temperature range	-10 °C, +50 °C	-10 °C, +50 °C	-10 °C, +50 °C	-10 °C, +50 °C	-10 °C, +50 °C	-40 °C, +55 °C	-40 °C, +55 °C	-15 °C, +50 °C	-15 °C, +50 °C
Warranty and electrical safety									
Warranty (years)	3	3	3	3	3	Limited lifetime	Limited lifetime	3	3
Input alert						•	•	•	
IP Rating	IP42	IP42	IP42	IP42	IP42	IP67	IP67	IP67	IP40
Safety rating (EN 61010) CAT III	600 V	600 V	600 V	600 V		1000 V	1000 V	1000 V	1000 V
Safety rating (EN 61010) CAT IV					600 V	600 V	600 V	600 V	600 V



Fluke 3000 FC True-rms Wireless Multimeter

Reduce the risk of arc flash and stay safe

The Fluke 3000 FC True-rms Wireless Multimeter and Fluke Connect wireless test tools keep you safe from hazardous measurement situations. Just deenergize the cabinet, open the panel while wearing PPE and connect the remote modules, whether they are voltage modules, current clamps, flexible current loops or thermometers. Then, from a safe distance, read the results on the 3000 FC True-rms Wireless Multimeter.

You can display the meter measurement, plus readings from up to three wireless modules. Better still, the Fluke 3000 FC True-rms Wireless Multimeter can send measurement data to your smartphone, so you can save and share measurements from the field with your team anytime, from anywhere.

The Fluke 3000 FC True-rms Wireless Multimeter with the Fluke Connect® app has all the essentials for convenient test and measurement troubleshooting.

- AC and dc voltage measurements to 1000 V
- AC and dc current with 0.01 mA resolution
- Continuity, resistance, diode test, capacitance and frequency measurements
- Min/Max recording
- CAT III 1000 V, CAT IV 600 V; IP54



Specifications

Functions	Range and resolution	Basic accuracy
AC voltage	600.0 mV, 6.000 V, 60.00 V, 600.0 V, 1000 V	1.0 % + 3
DC voltage	600.0 mV, 6.000 V, 60.00 V, 600.0 V, 1000 V	0.09 % + 2
Continuity		Meter beeps at < 25 Ω, beeper detects opens or shorts of 250 μs or longer
Resistance	600 Ω, 600.0 Ω, 6.000 kΩ, 60.00 kΩ, 60.00 kΩ, 600.0 kΩ, 50.00 MΩ	0.5 % + 1
Diode test	2.000 V	1 % + 2
Capacitance	1000 nF, 10.00 μF, 100.0 μF, 9999 μF ¹	1.2 % + 2
mA AC (45 Hz to 1 kHz)	60.00 mA, 400.0 mA ³	1.5 % + 3
mA dc ²	60.00 mA, 400.0 mA ³	0.5 % + 3
Frequency	0.01 Hz, 0.1 Hz, 0.001 kHz, 0.01 kHz	0.1 % + 1

¹In the 9999 μF range for measurements to 1000 μF, the measurement accuracy is 1.2 % + 2.

²Input burden voltage (typical): 400 mA input 2 mV/mA.

³400.0 mA accuracy specified up to 600 mA overload.

For all specifications: accuracy is specified for one year after calibration, at operating temperatures of 18 °C to 28 °C, with relative humidity at 0 % to 90 %. Accuracy specifications take the form of ± ([% of Reading] + [Number of least significant digits]). (Not compatible with Fluke CNX test tools)

Ordering information

Models	Included accessories
FLK-3000FC FC Wireless Digital Multimeter	Test leads, alligator clips, holster, AA batteries installed, information packet

Kits—buy more, save more



Recommended accessories

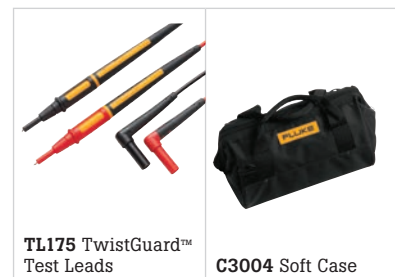

See our **NEW** products on pages 6 and 17!

Fluke 170 Series Digital Multimeters

Maintenance experts can find most electrical and HVAC problems

The Fluke 170 Series True-rms Multimeters is simple to use with significant improvements over the original Fluke 70 Series.

- Wide 1000 V measurement range
- True-rms for precise measurement of non-linear signals
- Capacitance, resistance, continuity and frequency
- Built-in thermometer (Fluke 179 only)
- Backlight for work in dimly lit areas (Fluke 177 and 179 only)
- Min/Max/Avg to record signal fluctuations
- Display hold and auto hold
- Manual and automatic ranging
- Basic dc accuracy (179/0.09%, 177/0.09%, 175/0.15%)
- Also available: 177 with true-rms and backlight and 175 with true-rms

Specifications

DC voltage	600.0 mV, 6.000 V, 60.00 V, 600.0 V, 1000 V	± 0.09% (Models 177 and 179) ± 0.15% (Model 175)
AC voltage ¹	600.0 mV, 6.000 V, 60.00 V, 600.0 V, 1000 V	± 1.0% of reading
DC current	60.00 mA, 400.0 mA, 6.000 A, 10.00 A ²	± 1.0% of reading
AC current ²	60.00 mA, 400.0 mA, 6.000 A, 10.00 A ²	± 1.5% of reading
Resistance	600.0 Ω, 6.000 kΩ, 60.00 kΩ, 600.0 kΩ, 6.000 MΩ, 50.00 MΩ	± 0.9% of reading
Capacitance	1000 nF, 10.00 μF, 100.0 μF, 9999 μF	± 1.2% of reading
Frequency ³	99.99 Hz, 999.9 Hz, 9.999 kHz, 99.99 kHz	± 0.1% of reading
Temperature (179 only)	-40 °C to +400 °C (-40 °F to +752 °F)	1.0% of reading
Battery life	200 hours typical for alkaline	
Dimensions (HxWxL)	4.3 cm x 9.0 cm x 18.5 cm (1.7 in x 3.5 in x 7.3 in)	

¹All ac voltage and ac current ranges are specified from 5% of range to 100% of range.

²10 A continuous, 20 A for up to 30 seconds.

³Voltage frequency is specified from 2 Hz to 100 kHz. Current frequency is specified from 2 Hz to 30 kHz.

Ordering information

Models	Included accessories
FLUKE-179 Digital Multimeter	TL75 Test leads, temperature probe, 9 V battery (installed), manual
FLUKE-177 Digital Multimeter	TL75 Test leads, 9 V battery (installed), manual
FLUKE-175 Digital Multimeter	TL75 Test leads, 9 V battery (installed), manual

Kits—buy more, save more

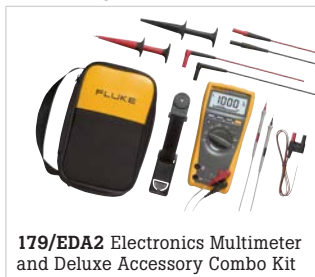

179/EDA2 Electronics Multimeter and Deluxe Accessory Combo Kit

Recommended accessories

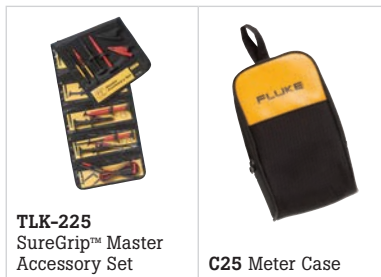

TLK-225 SureGrip™ Master Accessory Set

C25 Meter Case

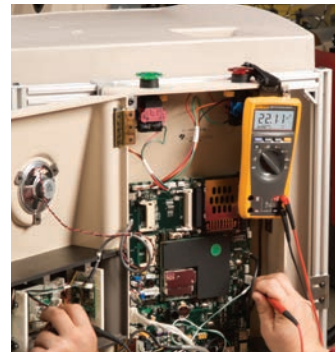

Fluke 289 and 287 True-rms Logging Multimeters

Find little problems before they become big ones

The Fluke 289 and 287 are high performance industrial logging multimeters. The large 50,000 count, 1/4 VGA dot matrix display and multiple on screen displays give you sharp, clear readings. Use the logging function with expanded memory for unattended monitoring of signals over time. With on-board TrendCapture, you can graphically review up to 10,000 recorded events and logged readings. Then, zoom on trend provides an unprecedented ability to zoom in up to 14 times to view and analyze data—all without needing a PC.

- Two terminal 50 ohm range with 1 milliohm resolution, 10 mA source current. Useful for measuring and comparing differences in motor winding resistance or contact resistance (289)
- Low-pass filter for accurate voltage and frequency measurements on adjustable speed motor drives and other electrically noisy equipment (289)
- Add the wireless capabilities of Fluke Connect® with Share-Live™ video call with the ir3000 FC connector
- True-rms ac bandwidth 100 kHz; dBV/dBm; dc mV resolution 1 μ V; Megohm range up to 500 M Ω
- Conductance 50.00 nS
- Min/Max/Avg/duty cycle/pulse width
- Isolated optical DMM interface with USB PC connection
- Over 200 hours logging capacity with new power saving function
- Lo Ohm capability; Lo Z volts; Lo Pass Filter



Specifications

Functions	Range and resolution	Basic accuracy
AC or dc voltage	50.000 mV, 500.00 mV, 5.0000 V, 50.000 V, 500.00 V, 1000.0 V	0.025 % 0.4 % (true-rms) (ac)
AC current dc current	500.00 μ A, 5000.0 μ A, 50.000 mA, 400.00 mA, 5.0000 A, 10.000 A	0.15 % 0.7 % (true-rms)
Temperature (excluding probe)	-200.0 °C to 1350.0 °C (-328.0 °F to 2462.0 °F)	1.0 %
Resistance	50.000 Ω , 500.00 Ω , 5.0000 k Ω , 50.000 k Ω , 500.00 k Ω , 5.0000 M Ω , 50.00 M Ω , 500.0 M Ω	0.05 %
Capacitance	1.000 nF, 10.00 nF, 100.0 nF, 1.000 μ F, 10.00 μ F, 100.0 μ F, 1000 μ F, 10.00 mF, 100 mF	1.0 %
Frequency	99.999 Hz, 999.99 Hz, 9.9999 kHz, 99.999 kHz, 999.99 kHz	.005 %

Ordering information

Models	Included accessories
FLUKE-289 True-rms Industrial Logging Multimeter with TrendCapture	Test leads, alligator clips, holster, AA batteries installed, information packet
FLUKE-287 True-rms Electronics Logging Multimeter with TrendCapture	Test leads, alligator clips, holster, AA batteries installed, information packet



Kits—buy more, save more

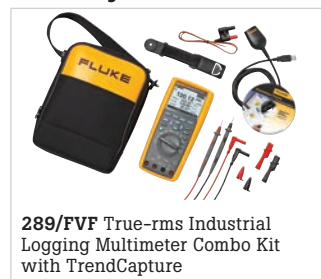

Recommended accessories

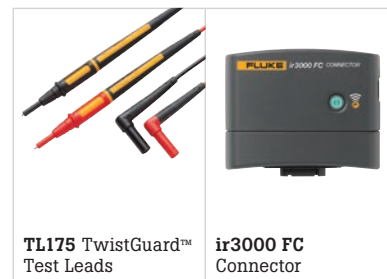

Fluke 87V Industrial Multimeters

The perfect DMM for a heavy industrial environment

The Fluke 87V Industrial Multimeter has measurement functions, trouble-shooting features, resolution and accuracy to solve industrial problems on motor drives, in-plant automation, power distribution and electro-mechanical equipment. The Fluke 87V Industrial Multimeter offers a unique function for accurate voltage and frequency measurements on adjustable speed motor drives and electrically noisy equipment. The large digit display with a bright, two level backlight makes it significantly easier to read.

Electrical safety

All inputs are protected to CAT III 1000 V and CAT IV 600 V. They can withstand impulses in excess of 8,000 V to help protect you from arc blast resulting from surges and spikes.

- Measure 20 A for up to 30 seconds, 10 A continuously
- Expanded capacitance range to 10,000 μF
- Peak capture to record transients as fast as 250 μs
- Measure up to 1000 V ac and dc
- Auto and manual ranging for maximum flexibility
- Frequency to 200 kHz and % duty cycle
- Min/Max/Avg recording to capture variations automatically
- Relative mode to remove test lead resistance from low ohms measurements
- Also available as 83V average responding multimeter



Specifications

Functions	Range and resolution	Basic accuracy	
		87V	83V
DC voltage	600.0 mV, 6.000 V, 60.00 V, 600.0 V, 1000 V	0.05 %	0.1 %
AC voltage	600.0 mV, 6.000 V, 60.00 V, 600.0 V, 1000 V	0.7 % (true-rms)	0.5 %
DC current	600.0 μA , 6000 μA , 60.00 μA , 600.0 mA, 6.000 A, 10.00 A	0.2 %	0.4 %
AC current	600.0 μA , 6000 μA , 60.00 μA , 600.0 mA, 6.000 A, 10.00 A	1.0 % (true-rms)	1.2 %
Temperature (excluding probe)	-200 °C to 1090 °C (-328 °F to 1994 °F)	1.0 %	
Temperature probe	-40 °C to 260 °C (-40 °F to 500 °F)	2.2 °C or 2 %	
Resistance	600.0 Ω , 6.000 k Ω , 60.00 k Ω , 600.0 k Ω , 6.000 M Ω , 50.00 M Ω	0.2 %	0.4 %
Capacitance	10.00 nF, 100.0 nF, 1.000 μF , 10.00 μF , 100.0 μF , 9,999 μF	1.0 %	1.0 %
Frequency	199.99 Hz, 1.9999 kHz, 19.999 kHz, 199.99 kHz	0.005 %	0.005 %
Battery life	400 hours typical with backlight off		
Dimensions (LxWxD)/Weight	201 mm x 98 mm x 52 mm (7.9 in x 3.8 in x 2 in)/355 g (22 oz)		

Ordering information

Models	Included accessories
FLUKE-87-5 Industrial True-rms Multimeter with Temperature	Test leads, alligator clips, holster, batteries (installed), temperature probe (87V only), information packet
FLUKE-83-5 Industrial Multimeter	Test leads, alligator clips, holster, batteries (installed), temperature probe (87V only), information packet

Kits—buy more, save more

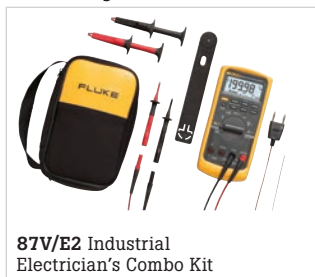

Recommended accessories



DIGITAL MULTIMETERS



Fluke 27 II, 28 II and 28 II Ex Digital Multimeters

Designed for tough work environments

The 27 II, 28 II and 28 II Ex Digital Multimeters all have IP67 waterproof and dustproof rating. They also have an extended operating temperature range of -15 °C to +55 °C (5 °F to 131 °F) and 95% humidity. These meters offer unique functions for accurate voltage and frequency measurements on adjustable speed motor drives and electrically noisy equipment (28 II and 28 II Ex). A built in thermometer allows you to take temperature readings without having to carry a separate instrument.

- Resistance and continuity. Relative mode to remove test lead resistance from low ohms measurements
- MSHA, CSA and TÜV approvals (27 II, 28 II)
- Intrinsically safe certifications from the world's leading certification bodies (28 II Ex, pg 67)
- Tested to withstand a 3 m (10 ft) drop
- Wide 1000 V measurement range
- True-rms ac voltage and current for accurate measurements on non-linear signals (28 II, 28 II Ex)
- Low pass filter (28 II, 28 II Ex)
- Average responding voltage and current measurements (27 II)
- 10 A continuous (20 A for 30 seconds)
- Frequency and capacitance
- Record signal fluctuations using the Min/Max function



Specifications

	27 II	28 II	28 II Ex
Volts ac, dc	1000 V		
Amps ac, dc	10A		
Resistance	0.1 Ω to 50 MΩ		
Display counts	6000	6000/19,999	6000/19,999
Temperature	-200 °C to +1090 °C		-200 °C to +1090 °C
Low pass filter (measurement on VSD's)	•		•
Safety rating (EN 61010)	CAT IV 600 V, CAT III 1000 V		
Measurement method	Avg. responding	True-rms	True-rms
Power	Three AA batteries		
Battery life	800 hours	400 hours	
Dimensions (DxWxH)	6.35 cm x 10.0 cm x 19.81 cm (2.5 in x 3.93 in x 7.8 in)		
Weight with holster	698.5 g (1.54 lb)		

Ordering information

Models	Included accessories
FLUKE-28-II Industrial Multimeter	Test leads, temperature probe, alligator clips, batteries, holster, information pack
FLUKE-28-II EX Intrinsically Safe Industrial Multimeter See page 67 for more information	Test leads, temperature probe, alligator clips, batteries, holster, information pack
FLUKE-27-II Industrial Multimeter	Test leads, temperature probe, alligator clips, batteries, holster, information pack

Recommended accessories

 <p>TLK-225 SureGrip™ Master Accessory Set</p>	 <p>PV350 Pressure-Vacuum Module</p>	 <p>TL225 Stray Voltage Adapter Test Lead Kit</p>	 <p>C550 Tool Bag</p>
--	--	--	---



Fluke 233 Remote Display Digital Multimeter

Now, you can be in two places at once

The Fluke 233 Remote Display Digital Multimeter has a removable display that solves several problems. First, you no longer have to hold both the meter and the test leads to make a measurement. Second, it allows you to measure where the measurement point is separated from controls or where the operator can't stay close to the meter during measurements due to various hazards or moving machinery. Third, Fluke's wireless technology allows the display to be carried up to 9 m (30 feet) away from the point of measurement for added flexibility and the removable magnetic display can be conveniently mounted where it is easily seen.

- Low-power 802.15.4 wireless technology does not interfere with measurement accuracy
- Use as a conventional multimeter when the display is connected
- True-rms ac voltage and current; built-in thermometer
- Radio transmitter automatically turns off when the display is connected to the meter
- Record signal fluctuations using the Min/Max function
- Measure up to 1000 V ac and dc
- Measure up to 10 A (20 A for 30 seconds)
- 10,000 μF capacitance range
- Frequency up to 50 kHz
- Resistance, continuity and diode test
- Min/Max/Avg recording to capture variations automatically
- New, improved battery life



Specifications

Functions	Specifications	
DC voltage	Range	0.1 mV to 1000 V
	Accuracy	0.25% + 2
AC voltage	Range	0.1 mV to 1000 V
	Accuracy	1.0% + 3
DC current	Range	0.001 A to 10 A
	Accuracy	1.0% + 3
AC current	Range	0.001 A to 10 A
	Accuracy	1.5% + 3
Resistance	Range	0.1 Ω to 40 M Ω
Capacitance		1000 nF to 9999 μF
Frequency		0.1 Hz to 50.00 kHz
Temperature		-40 °C to +400 °C (-40 °F to 752 °F)
Power	Three AA batteries main body, two AA batteries display module	
Battery life	400 hours	
Safety rating	CAT IV 600 V, CAT III 1000 V	
Size (HxWxL)	5.3 cm x 5.3 cm x 19.3 cm (2.08 in x 2.08 in x 7.6 in)	
Weight	604 g (1.3 lb)	



Ordering information

Models	Included accessories
FLUKE-233 Remote Display Multimeter	Test leads, temperature probe, alligator clips, batteries, information pack

Recommended accessories

<p>80PK-22 SureGrip™ Immersion Temperature Probe</p>	<p>80AK-A Thermocouple Adapter</p>	<p>TL220 SureGrip™ Industrial Test Lead Set</p>	<p>TLK289 SureGrip™ Industrial Master Test Lead Set and Case</p>
---	---	--	---

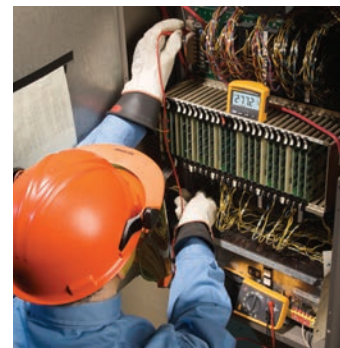

DIGITAL MULTIMETERS



Fluke 11X Series True-rms Digital Multimeters

Dependable DMMs for electrical and HVAC purposes

The Fluke 117 Digital Multimeter includes integrated non-contact voltage detection to help get the job done faster. The Fluke 115 Digital Multimeter is the solution for a wide variety of electrical and electronic testing applications.

The Fluke 116 Digital Multimeter was specifically designed for the HVAC professional. The Fluke 114 Digital Multimeter is the best troubleshooting tool for “go/no-go” testing and the 113 is a basic electrical and utility multimeter.

- VoltAlert™ technology for integrated non-contact voltage detection (117)
- AutoVolt feature for automatic ac/dc voltage selection (117, 116, 114)
- Built in thermometer for HVAC applications (116)
- Microamps to test flame sensors (116)
- VCHEK™ LoZ low impedance measurement function to simultaneously test for voltage or continuity (113)
- LoZ: Low input impedance prevents false readings due to “ghost voltage” (117, 116, 114)
- Min/Max/Avg to record signal fluctuations
- Large display and white LED backlight to work in poorly lit areas more effectively
- Compact ergonomic design for one-handed operation

Specifications

Functions	117	116	115	114	113
AC/DC voltage	600 V	600 V	600 V	600 V	600 V
AC/DC current	10 A	600.0 μ A	10 A		
Resistance	40 M Ω	40 M Ω	40 M Ω	40 M Ω	60 k Ω
Capacitance	1 nF to 9,999 μ F	1 nF to 9,999 μ F	1 nF to 9,999 μ F		
Diode test	•		•		•
Frequency	5 Hz to 99.99 kHz	5 Hz to 99.99 kHz	5 Hz to 99.99 kHz		
Temperature		+400 °C			
Safety rating	CAT III 600 V	CAT III 600 V	CAT III 600 V	CAT III 600 V	CAT IV 600 V

Ordering information

Models	Included accessories
FLUKE-117 Multimeter with Non-Contact Voltage	Test leads, holster, users manual and 9 V battery (installed)
FLUKE-116 HVAC Multimeter with Temperature and Microamps	Test leads, integrated temperature probe, holster, users manual and 9 V battery (installed)
FLUKE-115 Multimeter	Test leads, holster, users manual and 9 V battery (installed)
FLUKE-114 Electrical Multimeter	Test leads, holster, users manual and 9 V battery (installed)
FLUKE-113 Utility Meter	Test leads, holster, users manual and 9 V battery (installed)



Kits—buy more, save more

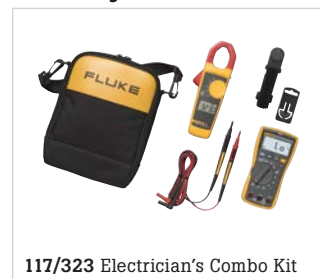

Recommended accessories

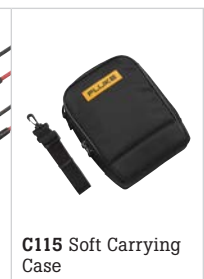
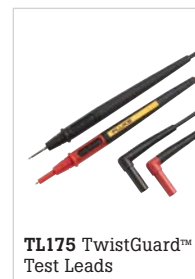

Fluke 88V and 77 IV Digital Multimeters

Fluke 88V Automotive Multimeter—designed to help automotive professionals solve problems faster

The Fluke 88V Automotive Multimeter has the measurement functions, troubleshooting features and accuracy to solve virtually any problem with conventional and hybrid vehicles.

- Automotive test functions include dc and ac voltage, resistance and current
- Min/Max recording for logging the highest and lowest readings over time
- Frequency measurements for magnetic sensors and ac/dc frequency signals
- Duty cycle for variable duty cycle signals with selectable trigger, slope and level
- Pulse width for fuel injector on-time measurements
- Conductance testing for secondary ignition coils
- RPM measurements for DIS and conventional ignition systems
- Built-in thermometer

Fluke 77 IV Digital Multimeter—use to repair most electrical and electronic problems

The Fluke 77 IV Digital Multimeter is simple to use and has significant improvements over Fluke's original 70 Series with more measurement functions, conformance to the latest safety standards, and a much larger display that is easier to view.

- Wide 1000 V measurement range
- Average responding ac measurements
- 0.3 % accuracy
- 10 amps continuous
- Frequency and capacitance
- Resistance and continuity
- Min/Max to record signal fluctuations
- Auto and manual ranging

Specifications

	88V	77IV
DC voltage	1000 V	1000 V
AC voltage	1000 V	1000 V
DC current	10 A	10 A
AC current	10 A	10 A
Resistance	50 MΩ	50 MΩ
Capacitance	9,999 μF	9,999 μF
Frequency	200.00 kHz	99.99 kHz
Duty Cycle	99.9%	
Temperature	1994.0 °F (1090 °C)	
Conductance	60.00 nS	

Ordering information

Models	Included accessories
FLUKE-88-5 Automotive Multimeter	Test leads, 9 V battery (installed), information packet
FLUKE-77-4 Digital Multimeter	Test leads, 9 V battery (installed), information packet

Kits—buy more, save more

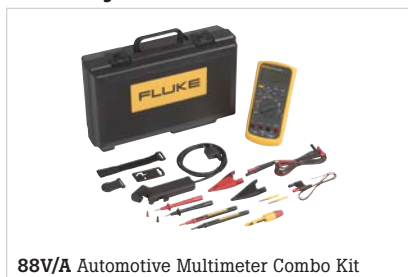

Recommended accessories

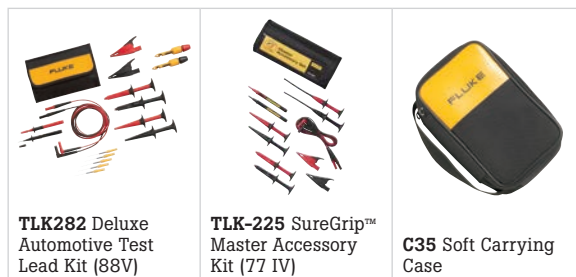

Clamp meter selection guide

	Residential/commercial electrical			General purpose		
	323	324	325	365	373	374 FC
Measurements						
AC current	•	•	•	•	•	•
AC voltage	•	•	•	•	•	•
Resistance	•	•	•	•	•	•
Continuity	•	•	•	•	•	•
DC volts	•	•	•	•	•	•
DC current			•	•		•
True-rms	•	•	•	•	•	•
Frequency			•			
AC + DC voltage						
AC + DC current						
Min/Max/Avg						•
4–20 mA (0.01 mA resolution)						
Temperature		•	•			
Capacitance		•	•		•	•
Measurement logging						
Special features						
Inrush current mode						•
Low Pass filter for VFD's						
Harmonics, power, data logging						
18-inch (45.7 cm) iFlex Flexible Current Probe						Optional
10-inch (25.4 cm) iFlex Flexible Current Probe						Optional
Remote display						in phone app
Wireless						•
Display						
Display hold	•	•	•	•	•	•
Backlight		•	•	•	•	•
Graphing display						in phone app
Specifications						
Jaw opening	30 mm (1.18 in)	30 mm (1.18 in)	30 mm (1.18 in)	18 mm (0.7 in)	32 mm (1.26 in)	34 mm (1.33 in)
Max wire size	300 mm ²	300 mm ²	300 mm ²	17 mm (0.67 in)	400 mm ²	400 mm ²
Current range ac rms	0 to 400.0 A	0 to 400.0 A/ 400.0 A	0 to 400.0 A/ 400.0 A	0 to 200.0 A	0 to 600.0 A	0 to 600.0 A (2500 A with iFlex)
Accuracy ac current (50/60 Hz)	2 % ± 5 counts	2 % ± 5 counts	2 % ± 5 counts	2 % ± 5 counts	2 % ± 5 counts	2 % ± 5 counts
AC Response	True-rms	True-rms	True-rms	True-rms	True-rms	True-rms
Current range dc			0 to 400.0 A/ 400.0 A	0 to 200 A		0 to 600.0 A
Accuracy dc current			2 % ± 5 counts	2 % ± 5 counts		2 % ± 5 counts
Voltage range ac	0 to 600.0 V	0 to 600.0 V	0 to 600.0 V	0 to 600.0 V	0 to 600.0 V	0 to 1000 V
Accuracy ac voltage	1.5 % ± 5 counts	1.5 % ± 5 counts	1.5 % ± 5 counts	2 % ± 5 counts	1 % ± 5 counts	1.5 % ± 5 counts
Voltage range dc	0 to 600.0 V	0 to 600.0 V	0 to 600.0 V	0 to 600.0 V	0 to 600.0 V	0 to 1000 V
Accuracy dc voltage	1.0 % ± 5 counts	1.0 % ± 5 counts	1.0 % ± 5 counts	2 % ± 5 counts	1 % ± 5 counts	1 % ± 5 counts
Resistance range	0 to 4000 Ω	0 to 4000 Ω	0 to 40 kΩ	0 to 6000 Ω	0 to 6000 Ω	0 to 6000 Ω
Frequency measurement range			5 Hz to 500 Hz			
Unit power						
Auto off	•	•	•		•	•
Warranty and safety						
Warranty (years)	2	2	2	3	3	3
Safety rating (EN 61010)	CAT IV 300 V, CAT III 600 V	CAT IV 300 V, CAT III 600 V	CAT IV 300 V, CAT III 600 V	CAT III 600 V	CAT III 600 V, CAT IV 300 V	CAT III 1000 V, CAT IV 600 V
Fluke Connect						
Compatible with Fluke Connect® app						•
Compatible with Fluke Connect® Assets software						•

CLAMP METERS



Fluke 370 Series Clamp Meters

Unprecedented measurement flexibility

The Fluke 370 FC Series clamp meters offer advanced troubleshooting performance plus Fluke Connect features to log and transmit data wirelessly.

Now you are able to log and trend measurements (the 376 FC and 375 FC have internal memory for up to 65,000 measurements), capture measurements outside the arcflash zone with Bluetooth® connectivity to your Apple® or Android® devices, transmit results wirelessly via the Fluke Connect Measurements app, and create and send reports right from the field.

The Fluke 370 FC Series Clamp Meters have a large backlit display, true-rms standard, CAT IV safety rating and a durably constructed body. Additionally, the 376 FC, 375 FC and 374 FC are compatible with the iFlex® Flexible Current Probe that measure up to 2500a ac.



Ordering information

Models	Included accessories
FLUKE-373 True-rms Wireless AC Clamp Meter	Test leads, soft carrying case, instruction card, safety information sheet, two AA alkaline batteries.
FLUKE-374 FC True-rms Wireless AC/DC Clamp Meter	Test leads, soft carrying case, instruction card, safety information sheet, two AA alkaline batteries.
FLUKE-375 FC True-rms Wireless AC/DC Clamp Meter	Test leads, soft carrying case, instruction card, safety information sheet, two AA alkaline batteries.
FLUKE-376 FC True-rms Wireless AC/DC Clamp Meter with iFlex	18-inch (45.7 cm) iFlex flexible current probe, test leads, TPAK magnetic hanging strap, soft carrying case, instruction card, safety information sheet, two AA alkaline batteries.

Fluke 320 Series True-rms Clamp Meters

Go to work with the best

The small and rugged 320 Series True-rms Clamp Meters are the best general troubleshooting tools for commercial and residential electricians and are designed to verify the presence of load current, ac voltage and continuity of circuits, switches, fuses and contacts. The Fluke 325 also offers dc current and frequency measurements.

- 400 A ac current measurement (ac and dc current; 325 only) and 600 V ac and dc voltage measurement
- Resistance measurement to up to 40 kΩ (325) and 4 kΩ (323 and 324) with continuity
- CAT IV 300 V/CAT III 600 V safety rating

Ordering information

Models	Included accessories
FLUKE-325 True-rms Clamp Meter	Test leads, temperature probe, soft case and users manual
FLUKE-324 True-rms Clamp Meter	Test leads, temperature probe, soft case and users manual
FLUKE-323 True-rms Clamp Meter	Test leads, soft case and users manual

Recommended accessories

Fluke 370 Series	Fluke 370 Series	Fluke 320 Series	Fluke 320 Series
i2500-10 10 inch (25.4 cm) iFlex® Flexible Current Probe	C43 Small Soft Case	TL175 TwistGuard™ Test Leads	L210 Probe Light and Extender

See our NEW products on pages 7 and 8!



Fluke 381 Remote Display True-rms AC/DC Clamp Meter with iFlex®

The world's most advanced clamp meter

The Fluke 381 Clamp Meter combines iFlex® flexibility with remote reading capability for the ultimate in innovation and safety. The remote display reads measurements up to 9 m (30 feet) away and the included iFlex Flexible current probe (18-inch/45.7 cm circumference) lets you easily get into tight spaces.

- 2500 A ac current measurement with iFlex
- 1000 A ac and dc current measurement with fixed jaw
- 1000 V ac and dc voltage measurement
- Frequency measurement to 500 Hz
- 60 kΩ resistance measurement
- Min/Max/Avg and inrush recording
- CAT IV 600 V, CAT III 1000 V
- Three-year warranty



Ordering information

Models	Included accessories
FLUKE-381 Remote Display True-rms AC/DC Clamp Meter with iFlex	18-inch (45.7 cm) iFlex Flexible Current Probe, test leads, soft carrying case, instruction card, safety information sheet, five AA alkaline batteries

Fluke 365 Detachable Jaw True-rms AC/DC Clamp Meter

Where rugged meets reliable

The Fluke 365 Clamp Meter offers a small, detachable jaw—with 1.2 m of coil—that makes it easy to take and read measurements in tight or hard-to-reach places.

- 200 A ac and dc current measurement
- 600 V ac and dc voltage measurement
- 6000 Ω resistance measurement
- Built-in flashlight
- Large, easy-to-read backlight display
- Three-year warranty



Ordering information

Models	Included accessories
FLUKE-365 Detachable Jaw True-rms AC/DC Clamp Meter	Test leads, soft carrying case, instruction card, safety information sheet, five AA alkaline batteries

Recommended accessories

Fluke 381	Fluke 381	Fluke 365	Fluke 365
AC285 SureGrip™ Alligator Clips	TLK289 Industrial Master Test Lead Set	TL220 SureGrip™ Industrial Test Lead Set	FTPL-1 SureGrip™ Fused Test Probe and Lead Set





Fluke 902 FC True-rms Wireless HVAC Clamp Meter



Helps HVAC pros keep up with the demands of their job

HVAC technicians require a service tool they can depend on to consistently meet the expectations of their job. The Fluke 902 FC expands the existing line of quality Fluke clamp meters by delivering the features necessary to diagnose and repair HVAC systems. Combined with Fluke Connect®, the Fluke 902 FC helps technicians do their jobs safely and accurately.

- Capture and trend measurements safely from outside the arc blast zone and easily create and send reports from the field with Fluke Connect®
- Designed for HVAC applications with capacitance, dc current (µA) and temperature measurements
- Small body and jaws fit perfectly in your hand and into tight places
- True-rms voltage and current for accurate measurements of non-linear signals
- Three-year warranty

Ordering information

Models	Included accessories
FLUKE-902 FC True-rms Wireless HVAC Clamp Meter	Test leads, temperature probe, soft carrying case, users manual, two AA alkaline batteries



Fluke 368 FC/369 FC AC True-rms Leakage Current Clamp Meter

Reduce downtime – Test leakage currents without taking equipment offline

The Fluke 368/369 Series of true-rms leakage current clamp meters help users detect, document, record and compare leakage current readings over time as a means of preventing unplanned downtime, and identifying intermittent GFCI and RCD trips, all without taking equipment off line.

Current measurement

- Automatic ranging within the manually selected mA or A range
- Ranges 3/30 mA and 30/60 A
- Current resolution 1 µA/0.01 mA and 0.01 A/0.1 A
- Selectable filter 40 Hz to 70 Hz or wideband 40 Hz to 1 kHz
- Frequency range 40 Hz to 1 kHz
- Jaw size: 40 mm (1.55 in) on 368 FC and 61 mm (2.4 in) on 369 FC
- Auto power off
- Torch light
- Logging
- Fluke Connect compatible



Ordering information

Models	Included accessories
FLUKE-368 FC AC Leakage Current Clamp Meter	Soft carrying case, users manual
FLUKE-369 FC AC Leakage Current Clamp Meter	Soft carrying case, users manual

Recommended accessories

Fluke 902	Fluke 902	Fluke 902	Fluke 902
AC220 SureGrip™ Alligator Clips	AC175 Alligator Clip Set	TL224 SureGrip™ Insulated Test Leads	C33 Soft Carrying Case



Wireless Fluke Connect® Current Meters

Take three-phase measurements in one-third of the time

Testing 3-phase is now faster and cheaper. When your cabinet is de-energized, attach the 3000 FC Wireless Current Clamp to each phase. You can solve problems faster by seeing live measurements from multiple test points on a single screen. Then, send data to your laptop and go from logging to analysis and diagnosis using the Fluke Connect® app or Fluke Connect® Assets software.

Fluke a3000 FC Wireless AC Current Clamp Meter

A fully functional true-rms current clamp meter that wirelessly relays measurements to other Fluke Connect® enabled master units.

- Measure up to 400 A ac

Fluke a3001 FC Wireless iFlex AC Current Meter

A true-rms flexible current meter that wirelessly relays measurements to other Fluke Connect enabled master units.

- Record over time to monitor circuit load changes for an hour, a shift or a week
- Measure up to 2500 A ac

Fluke a3002 FC Wireless AC/DC Current Meter Module

- Measure up to 400 A ac or 400 A dc with i410 (sold separately)
- Measure up to 600 A ac or 1000 A dc with i1010 (sold separately)
- Use as a standalone meter or as part of the system

Fluke a3003 FC Wireless 2000 A DC Current Clamp Meter

- Measure up to 2000 A DC
- Large jaw size (64 mm) for measuring large, high current conductors
- Use the logging function for the recording and saving up to 65,000 readings

Fluke a3004 FC Wireless 4-20 mA DC Current Meter

- Measure 4 to 20 mA signals without “breaking the loop”
- Detachable clamp with extension cable for measurements in tight locations
- Use the logging function for the recording and saving up to 65,000 readings

Ordering information

Models	Included accessories
FLK-a3000 FC Wireless AC Current Clamp Meter	Information pack
FLK-a3001 FC Wireless iFlex AC Current Meter	iFlex current probe, information pack, magnetic hanger
FLK-a3002 FC Wireless AC/DC Current Meter Module	Information pack, magnetic hanger
FLK-a3003 FC Wireless 2000 A DC Current Clamp Meter	2000 A DC Clamp, information pack, magnetic hanger
FLK-a3004 FC Wireless 4-20 mA DC Current Meter	4-20 mA DC current probe, information pack, hanging strap



Fluke a3003 FC Wireless 2000 A DC Current Clamp Meter



Fluke a3004 FC Wireless 4-20 mA DC Current Meter



Fluke 353 and 355 AC/DC True-rms Clamp Meters

Versatile, professional, accurate

Confidently take reliable readings with the true-rms Fluke 355 and 353 Clamp Meters—the tools of choice for high current clamp-on amp meter measurements up to 2000 A.

- Reliably handle a wide range of high-current applications with 2000 A ac + dc true-rms, 1400 A ac, and 2000 A dc
- High voltage measurement of 1000 V ac + dc true-rms, 600 V ac, and 1000 V dc (355 only)
- Resistance to 400 k Ω (355 only)
- Continuity beeper (355 only)
- Frequency measurement to 1 kHz
- Selectable low-pass filter mode
- Min/Max/Avg

Ordering information

Models	Included accessories
FLUKE-355 AC/DC True-rms Clamp Meter	Soft carrying case, users manual
FLUKE-353 AC/DC True-rms Clamp Meter	Soft carrying case, users manual



Recommended accessories

<p>Fluke 350 Series</p>  <p>TL175 TwistGuard™ Test Leads</p>	<p>Fluke 350 Series</p>  <p>80TK Thermocouple Module</p>	<p>Fluke 350 Series</p>  <p>C345 Large Soft Case</p>	<p>Fluke 350 Series</p>  <p>C1600 Gear Tool Box</p>
--	--	---	---

Wireless Fluke Connect® Meters

Wirelessly relay measurements using Fluke Connect®

Eliminate data entry by wirelessly syncing measurements from your tool.

v3000 FC Wireless AC Voltage Meter (not shown)

- Measure up to 1000 V true-rms AC
- Use as a standalone meter or as part of the system
- Logging function for recording and saving up to 65,000 readings

v3001 FC Wireless DC Voltage Meter

- Measure up to 1000 V DC
- Use as a standalone meter or as part of the system
- Logging function for recording and saving up to 65,000 readings

t3000 FC Wireless K-type Temperature Meter

- Use as a standalone meter (-200 °C to 1372 °C, 328 °F to 2501 °F) or as part of the system
- Logging function for recording and saving up to 65,000 readings

ir3000 FC Connector

- Supports 289 and 287 true-rms DMM; 189 DMM and 789 ProcessMeter™
- Fits over the IR port of your existing Fluke tools
- Enables you to graph, save, and share readings with your team from your smart phone

pc3000 FC Wireless PC Adapter

- Collects up to 65,000 sets of time stamped min/max/avg readings from FC remote modules
- Display up to six simultaneous live readings via included Windows sw3000 FC Software



Fluke t3000 FC Wireless K-type Temperature Meter



Fluke v3001 FC Wireless DC Voltage Meter

Ordering information

Models	Included accessories
FLK-a3000 FC Wireless AC Current Clamp Meter	Test leads, information pack, and alligator clips
FLK-a3001 FC Wireless iFlex® AC Current Meter	iFlex current probe, information pack, and magnetic hanger
FLK-a3002 FC Wireless AC/DC Current Meter	Magnetic hanger and information pack
FLK-a3003 FC Wireless 2000 A DC Current Clamp Meter	2000 A DC Clamp, information pack, and magnetic hanger
FLK-a3004 FC Wireless 4-20 mA DC Current Meter	4-20 mA DC current probe, information pack, and hanging strap
FLK-v3000 FC Wireless AC Voltage Meter	Test leads, alligator clips, magnetic hanger, and information pack
FLK-v3001 FC Wireless DC Voltage Meter	Test leads, alligator clips, magnetic hanger, and information pack
FLK-t3000 FC Wireless K-type Temperature Meter	Temperature probe, magnetic hanger, and information pack
FLUKE-ir3000 FC Connector	Compatible with: Fluke 789, 289, 287, 189
FLK-PC3000 Wireless PC Adapter	



Fluke ir3000 FC Connector



Fluke Connect Wireless PC Adapter

The largest suite of connected test tools in the world



Fluke 8846A, 8845A and 8808A Precision Bench Multimeters



Performs functions expected in multifunction digital multimeters

The Fluke 8846A/8845A 6.5 Digit Precision Multimeters measure volts, ohms and amps. Basic V dc accuracy of up to 0.0024 %, 10 A current range, and a wide ohms range give you an unbeatable combination of measurement capability.

Extend the meters' utility even more with their graphical display modes, including Trendplot™ paperless recorder mode, statistics and histograms—features you won't find on other multimeters

- 6.5 digit resolution
- Up to 0.0024 % accuracy
- Graphical analysis modes: TrendPlot, Histogram, and Statistics
- Dual measurement inputs: front/rear
- Wide measurement ranges
- IEEE, LAN, RS-232 interfaces
- USB memory device port (8846A)
- TL2X4 wire measurement technique
- Three-year warranty



Fluke 8808A 5.5 Digit Multimeter

The Fluke 8808A multimeter has a broad range of functions, measuring volts, ohms and amps with a basic V dc accuracy of 0.015 %. The meter is easy to use and include innovative functions to simplify routine testing and precision 4 wire resistance measurements.

- 5.5 digit resolution
- Up to 0.015 % accuracy
- Sensitive dc leakage current ranges
- Front panel setup keys
- TL2X4 wire measurement technique
- Three-year warranty



Built-in TrendPlot graphically plots extent of drift and intermittent events.



Histogram mode can reveal stability or noise problems.

Make true 4-wire measurements with just two leads.

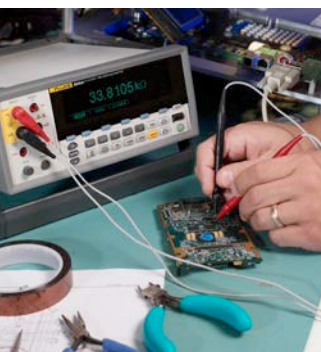

Specifications

	Fluke 8808A	Fluke 8845A	8846A
Display	dual	dual, graphical	
Resolution (No. of digits)	5.5	6.5	
Measurements	V ac, V dc, I dc, I ac, Ω, Cont, Diode	V ac, V dc, I dc, I ac, Ω, Cont, Diode	
Basic V dc accuracy (% Reading + % Range)	0.015 + 0.003	0.0035 + 0.0005	0.0024 + 0.0005
Advanced measurements/functions	2x4 wire ohms, freq, i-Leakage, dedicated setup keys	2x4 wire ohms, freq, period	2x4 wire ohms, freq, period, capacitance, temp (RTD)
Math	Null, dBm, dB, Min, Max	Null, dBm, dB, Min, Max, Ave, Std Deviation, MX+B	
Analysis	Limit Compare	Limit Compare, TrendPlot, Histogram, Statistics	
USB memory device port			•
Interfaces	RS-232, USB via optional adapter	RS-232, IEEE-488.2, LAN, USB via optional adapter	
Safety rating	CAT II 600 V	CAT II 600 V	

Ordering information

Models	Included accessories
FLUKE-8846A 6.5 Digit Precision Multimeter, 24 ppm USB memory	Power cord, test lead set, programmers manual/users manual on CD, FVF-BASIC, FlukeView Forms Software Basic Version
FLUKE-8845A 6.5 Digit Precision Multimeter, 35 ppm	Power cord, test lead set, programmers manual/users manual on CD, FVF-BASIC, FlukeView Forms Software Basic Version
FLUKE-8808A 5.5 Digit Multimeter	Test leads, line cord, getting started guide, users manual on CD

Fluke 424D, 419D and 414D Laser Distance Meters

Measure farther, with greater accuracy, in more situations

The Fluke family of laser distance meters are essential tools in the tool bag. They provide, instant and accurate measurements up to ± 1 mm with no scales to interpret or misread. Just point, click, done. The 424D has an inclination sensor that helps with leveling, height tracking and, measuring around obstacles. Find area and volume, easily add and subtract distances and calculate height. Easily measure hard-to-access areas without climbing a ladder and without the need for a helper.

Specifications

	Fluke 424D	Fluke 419D	Fluke 414D
Maximum measurement distance	100 m (330 ft)	80 m (260 ft)	50 m (165 ft)
Accuracy	± 1 mm (± 0.04 in)	± 1 mm (± 0.04 in)	± 2 mm (± 0.08 in)
Battery life (number of measurements)	5000	5000	3000
Area measurement	•	•	•
Volume measurement	•	•	•
Pythagoras calculations	Full	Full	1+2
Plus and minus calculations	•	•	•
Measurement storage	20 complete displays	20 complete displays	5 results
Min/Max	•	•	Yes(Pyth)
Tripod mount	•	•	
Corner angle measurement	•		
Stake out	•	•	
Inclination sensor	•		
Display	4 line	3 line	2 line
Automated end-piece correction	•	•	

Ordering information

Models	Included accessories
Fluke 424D Laser Distance Meter	Two AAA batteries, users manual on CD, quick reference guide, vinyl carrying pouch, and three-year warranty
Fluke 419D Laser Distance Meter	Two AAA batteries, users manual on CD, quick reference guide, vinyl carrying pouch, and three-year warranty
Fluke 414D Laser Distance Meter	Two AAA batteries, users manual on CD, quick reference guide, vinyl carrying pouch, and three-year warranty

Kits—buy more, save more



Complies with EN 60825-1:2007 (Class II)



EARTH GROUND TESTERS



Selection guide

	1630	1621	1623-2	1625-2
2-Pole (ac) resistance measurement		•	•	•
3-Pole earth measurement		•	•	•
Measurement frequency—128 Hz		•	•	
4-Pole earth ground and soil resistivity measurement			•	•
Selective testing			•	•
Stakeless testing (ground loop resistance)	•		•	•
Memory			•	•
USB port			•	•
Automatic Frequency Control (AFC) 94 Hz to 128 Hz				•
R* measurement				•
Adjustable limits				•

Fluke 1625-2 and 1623-2 Geo Earth Ground Testers

Simpler, faster testing

Grounding testers, like the Fluke 1623-2 and 1625-2, help maintain uptime and lower the risk of electric shock to users while helping solve intermittent power quality problems. The Fluke earth ground testers perform all four essential earth ground test methods that users demand:

- 3- and 4-pole Fall of Potential, earth resistance loop testing
- 4-pole soil resistivity testing
- Selective earth ground testing using one clamp
- Stakeless earth ground testing using two clamps

The 1623-2 and 1625-2 also make earth grounding tests faster and easier than previous methods because of automatic data collection and storage and faster setup. Color coded wires for easier identification and deploying of wire reels and stakes.

- IP56 rated for outdoor use
- USB data storage and transfer
- Automatic Frequency Control (AFC)—identifies existing interference and chooses a measurement frequency to minimize its effect, providing more accurate earth ground value
- R* measurement—calculates earth ground impedance at 55 Hz to more accurately reflect the earth ground resistance that a fault-to-earth ground would see
- Adjustable limits—for quicker testing

Ordering information

Models	Included accessories
FLUKE-1625-2 Advanced GEO Earth Ground Tester	Two test leads, USB cable, batteries, quick reference guide, users manual
FLUKE-1623-2 Basic GEO Earth Ground Tester	Two test leads, USB cable, batteries, quick reference guide, users manual
FLUKE-1625-2 KIT Advanced GEO Earth Ground Tester Kit	Two test leads, USB cable, 2 clamps (1 source, 1 sensing), carrying case, 4 earth ground stakes, 3 color coded cable reels, batteries, quick reference guide, users manual
FLUKE-1623-2 KIT Basic GEO Earth Ground Tester Kit	Two test leads, USB cable, 2 clamps (1 source, 1 sensing), carrying case, 4 earth ground stakes, 3 color coded cable reels, batteries, quick reference guide, users manual

These products are for unpowered installations measuring grounding connections.

Kits—buy more, save more

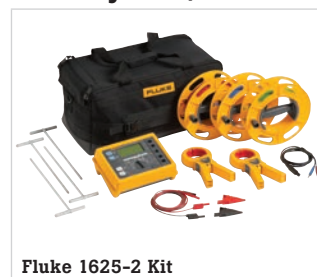

Fluke 1625-2 Kit

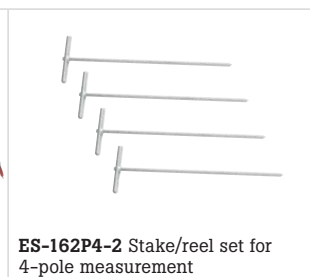

ES-162P4-2 Stake/reel set for 4-pole measurement

Recommended accessories



EI-1625 Selective/stakeless clamp set for 1625-2



EI-162BN 320 mm (12.6 in) Split Core Transformer for use with Fluke 1625-2



Faster setup, easier testing and deployment of wire reels and stakes.

Clamp-on transformer accessory for ground loop measurements on transmission pylons.



Fluke 1621 Basic Earth Ground Tester

Earth ground tester for resistance measurement

The Fluke 1621 Earth Ground Tester is a rugged, easy-to-use tester for three-pole ground resistance measurements and two-pole ac resistance measurements.

Earth ground resistance is measured by installing earth ground test electrodes, and testing. With a simple user interface and intuitive functionality, the large, clear LCD display provides high visibility results in daylight or poor lighting conditions.

- Three-pole earth resistance measurements
- Two-pole AC resistance measurements
- Large dual backlit display
- Limit settings for automatic measurement evaluation
- CAT II 600 V
- Two-year warranty

Ordering information

Models	Included accessories
FLUKE-1621 Basic Earth Ground Tester	Two measuring leads with alligator clips, 2 m (6 ft), yellow protective holster, 9 V alkaline battery (LR61), users manual, CD



Fluke 1630 Earth Ground Clamp Meter

Safely measures ground loop resistance

The Fluke 1630 Earth Ground Clamp Meter is able to measure ground loop resistances—using the stakeless testing method. This test technique eliminates the dangerous, and time consuming activity, of disconnecting parallel grounds. You can also perform earth ground tests: inside buildings, on power pylons or anywhere you don't have access to soil.

With the stakeless testing method, no earth ground stakes are used at all. A known voltage is induced by one half of the clamp and the current is measured by the other half. The tester automatically determines the ground loop resistance at this grounding connection.

- Quick and easy use—no earth ground stakes are necessary
- Large, 35 mm (1.35 in) jaw opening
- Measures ground resistance from 0.025 Ω to 1500 Ω
- Measures ground leakage current from 0.2 mA to 30 A
- High and low alarming
- Automatic self calibration
- Rugged carrying case and resistance check loop included
- Two-year warranty
- CAT III 300 V, CAT II 600

Ordering information

Models	Included accessories
FLUKE-1630 Earth Ground Clamp Meter	Rugged carrying case with belt, resistance test loop, 9 V battery, users manual



Take leakage current or ground measurements on grounding systems with multiple parallel grounding electrodes (transformers, utility grounds, transmission tower grounds, and communication ground systems).

Kits—buy more, save more

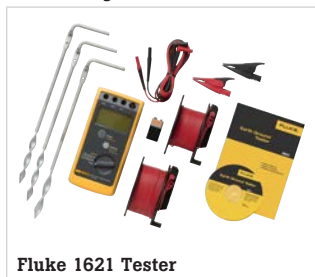

Fluke 1621 Tester

Recommended accessories



Cable Reel 50 m
Ground/earth wire (162.5 ft) for 1621

Cable Reel 25 m
Ground/earth wire (81.25 ft) for 1621

ES-162P3 Stake/reel set for 3-pole measurements for 1621



PORTABLE APPLIANCE TESTER



6200-2 and 6500-2 PAT Testers

The low weight, small size, one-touch solutions.

The Fluke 6200-2 and 6500-2 PAT testers have redesigned auto-test capabilities to help you increase the number of portable appliance tests completed each day. It is designed to enable you to work faster without compromising safety – yours or your customer's.

Fluke simplifies portable appliance testing

The Fluke 6200-2 offers:

- Dedicated key for each test for 'one touch' testing
- Pre-set pass/fail levels to save time
- Large backlit display for easy reading
- Single mains socket for appliance connection
- Separate IEC socket for easy mains/ extension lead testing
- Detachable test leads for quick field replacement
- Integral carrying handle
- USB port for data transfer

The Fluke 6500-2 delivers all of this capability, plus:

- Integral QWERTY keyboard for rapid data entry
- Additional USB memory capability for back-up data storage and transfer to PC
- Large backlit graphics display
- Pre-set, auto-test sequences for user convenience
- Integral site, location and description codes for faster data processing
- Memory review facility for more onsite control

Separate hard case

The compact Fluke PAT testers are supplied with a hard carrying case that not only offers protection during transit but also includes extra storage space for accessories and other tools. The PAT testers are extremely light, weighing approximately 3 kg (without case) and have integral carrying handles for extra convenience.



Ordering information

Models	Included accessories
FLUKE 6200-2 PAT Tester	Power cord, test lead set, programmers manual/users manual on CD, hard carrying case
FLUKE 6500-2 PAT Tester	

Not available in all regions

Kits—buy more, save more



Fluke 6200-2 UK/Kit

Fluke 6500-2 UK/Kit with DMS Software

Selection guide

	6200-2	6500-2
LN mains volts	•	•
Outside limits indicators	•	•
Null out facility for earth bond lead	•	•
Protective earth resistance PE (200 mA)	•	•
Protective earth resistance PE (25 A)	•	•
Insulation 500 V dc	•	•
Insulation 250 V dc		•
Protective earth conductor current	•	•
Touch current	•	•
RCD test		•
Substitute leakage current	•	•
Appliance power kVA	•	•
Appliance load current	•	•
Seven segment custom LCD	•	•
Color dot matrix display		•
Back light	•	•
USB port for printing	•	•
USB flash drive port (storage and download)		•
External printer output	•	•
Front panel QWERTY key pad		•
IEC lead test	•	•
Auto-testing		•
Pass/Fail level programmable indicators		•
Data storage		•
Limited data storage	•	
Polarity checks		•
Graphical help menu on line		•
Programme mode		•
Real time clock		•
Front panel results management		•
230 V test socket/230 V mains input power plug	•	•
110 V appliance test compatible with test lead adapter		•

Specifications

Mechanical and general specifications		
Size (LxWxH)	200 mm x 275 mm x 114 mm	
Weight	3.13 kg	
Power supply	230 V +10 % -15 %, 50 Hz ± 2 Hz or (6500-2 only: 110 V +10 % -15 %, 50 Hz ± 2 Hz)	
Power consumption (Tester)	13 W typical (idle) 60 W max. during 25 A Bond Test	
Storage	Temperature	-10 °C to 60 °C
	Corrosion	70 °C @ 95 % RH for 5 days max.
Operating temperature	0 °C to 40 °C	
Operating altitude	0 up to 2000 m	
Relative humidity	Non condensing < 10 °C 95 % from 10 °C to 30 °C 75 % from 30 °C to 40 °C	
Sealing	IP40 (enclosure), IP20 (connectors)	
EMC	Complies with EN61326-1, Portable	
EMI immunity	3 V/m	
Safety rating	Complies with EN61010-1 3rd edition, CAT II, 300 V, pol 2 German version only: DIN VDE0404-1 and DIN VDE0404-2 IEC/EN 61557, part 1, 2, 4, 6, 10 CAT II, 300 V, pol 2	





Fluke T5-1000



Fluke T5 Electrical Testers

Fluke T5-1000 and T5-600 Voltage, Continuity and Current Testers

- Excellent front-line troubleshooting and measurement tool
- Available in 600 V and 1000 V models
- OpenJaw™ current measurement
- Rotary switch selects volts, amps and ohms functions
- Heavy-duty test leads

Specifications

	T5-1000	T5-600
Measure ac/dc voltage	1000 V	600 V
Measure ac current (avg)	100 A	100 A
Measure continuity	< 25 Ω	< 25 Ω
Measure resistance	1000 Ω	1000 Ω
DC polarity indicator	•	•
Detachable probe tips w/optional tip styles	•	•
Digital display	•	•
Safety rating	1000 V Overvoltage CAT III	600 V Overvoltage CAT III
Warranty	Two-year	Two-year

*Voltage levels will vary depending on country of intended use.

Ordering information

Models	Included accessories
T5-1000 1000 V Voltage, Continuity and Current Tester	Detachable probes and instruction sheet
T5-600 600 V Voltage, Continuity and Current Tester	Detachable probes and instruction sheet



Kits—buy more, save more



Fluke T5-H5-1AC Kit

Fluke VoltAlert™ family

The next generation VoltAlert™ ac non-contact voltage testers from Fluke are easy to use. Electricians, maintenance, service and safety personnel, and homeowners can quickly test for energized circuits in the workplace or at home. Certified up to CAT IV 1000 V.

Fluke 1AC II VoltAlert™

The Fluke VoltAlert AC voltage detector is very easy to use – just touch the tip to a terminal strip, outlet or cord. When the tip glows red and the unit beeps, you know there is voltage on the line.

- It continually tests its battery and its circuit integrity with a periodic double flash visual indication.
- Highest safety rating: CAT IV 1000 V

2AC VoltAlert™

2AC is the latest addition to the VoltAlert™ AC non-contact voltage tester family from Fluke and is designed to be pocket-sized and easy to use.

- Voltage detection from 200 to 1000 V AC, suitable for a wide range of residential, commercial and industrial needs.
- Always on, using special low power circuitry to sustain battery life and ensure your 2AC is always ready.
- Innovative 'Battery Check' button function ensures battery is in good condition*
- Category IV – 1000 V overvoltage rated product for best in class user protection
- Two-year warranty storage.

LVD2 Volt Light

Combines bright light and voltage detection in one pen style design

- Dual sensitivity, detects voltage from 90 V to 600 V AC
- Detects voltage from 90 V to 600 V AC
- Rated to CAT IV 600 V

LVD1 Volt Light

Dual sensitivity voltage detector

- Detects voltage from 40 V to 300 V AC
- Comes with a versatile clip to secure light to pocket, hat or even panel door



Specifications

	2AC	1AC-II	1LAC-II	LVD2	LVD1
Voltage range	200 V ac to 1000 V ac	90 V ac to 1000 V ac	20 V ac to 90 V ac	90 V ac to 600 V ac	40 V ac to 300 V ac
Audible alert		•	•	•	•
Flashlight				•	•
On/Off	Always on	•	•	•	•
Safety rating	CAT IV 1000 V	CAT IV 1000 V	CAT IV 1000 V	CAT IV 600 V	CAT IV 600 V

Ordering information

Models
2AC VoltAlert™ Voltage Detector
1AC-II VoltAlert™ Voltage Detector
1LAC-II VoltAlert™ Voltage Detector
LVD2 Volt Light
LVD1 Volt Light

T90/T110/T130/T150 Voltage and Continuity Testers

Rugged, high-quality testers for fast test results the way you need them

All electricians need a two-pole tester. Experienced professionals know that they can—and should—trust their job, their reputation and even their personal safety to Fluke electrical test tools. Our new family of Two-Pole Voltage Testers is no exception. Built with state-of-the-art measurement and safety technology, these testers offer everything you expect from Fluke, and a little bit more.

- Rugged, high-quality construction is built to last. This includes a heavy duty molded case, a thicker cord with wear indicator, sturdy battery case, and well fitting and durable probe protector
- Fast test results the way you need them, with large, easy-to-use buttons, bright backlights, and clear audible and physical indicators designed for any work situation.
- Enhanced ergonomic design feels good in your hand, is easy to use (even with gloves on) and quick, secure probe docking.
- Compliant with regulation HSE GS 38 (tip caps) and IEC EN 61243-3:2014



Fluke T90



Fluke T110



Fluke T130



Fluke T150



Specifications

	T90	T110	T130	T150
Voltage AC/DC	12V - 690V		6V - 690V	
Continuity	0 - 400 kΩ			
Frequency	0 - 60 Hz	0 - 400 Hz		
Phase rotation	-	100 V - 690 V		
Resistance measurement	-	-	-	Up to 1999 Ω
Response Time (LED ladders)	< 0.1 s			
200 kΩ input impedance	Current draw 3,5 mA @ 690 V Current draw 1,15 mA @ 230 V			
7k Ω input impedance (with load buttons pressed)	-	Current draw 30 mA @ 230 V		
Safety rating	CAT II 690V CAT III 600V		CAT III 690V CAT IV 600V	
IP rating	IP54	IP64	IP64	IP64

Ordering information

Models	Included accessories
Fluke T90 Voltage/Continuity Tester	Two 2-AA batteries and instruction sheet
Fluke T110 Voltage/Continuity Tester with switchable load	
Fluke T130 Voltage/Continuity Tester with LCD, switchable load	
Fluke T150 Voltage/Continuity Tester with LCD, Ohms, switchable load	

Not available in all regions

Recommended accessories



H15 Electrical tester holster

C150 Soft carrying case

9040/9062 Phase Rotation Indicators

Take the guess work out of phase/motor rotation measurements

Fluke 9040

The Fluke 9040 is effective for measuring phase rotation in all areas where three-phase supplies are used to feed motors, drives and electrical systems. The Fluke 9040 is a rotary field indicator and can provide clear indication of the 3 phase via an LCD display and the phase rotation direction to determine correct connections. It allows rapid determination of phase sequence and has a voltage (up to 700 V) and frequency range suitable for commercial and industrial applications. Test probes supplied with the instrument have a variable clamping range for safe contact, especially in industrial sockets.

Fluke 9062

The unique Fluke 9062 provides rotary field and motor rotation indication with the benefits of contact-less detection. Purpose made for commercial and industrial environments, the Fluke 9062 provides rapid indication of 3 phase rotation using test leads supplied or can be used to determine motor rotation on synchronous and asynchronous 3 phase motors. The contact-less detection is ideal for use on motors where the shaft is not visible. Test probes supplied with the instrument have a variable clamping range for safe contact, especially in industrial sockets.

Specifications

	9040	9062
Voltage range	40 - 700 V	Up to 400 V
Phase display	-	120 - 400 V AC
Frequency range	15 - 400 Hz	2-400 Hz
Operating time	Continuous	Continuous

Ordering information

Models	Included accessories
FLUKE 9040 Phase Rotation Indicator	Three alligator clips , three standard test probes, three flexible test probes
FLUKE 9062 Motor and Phase Rotation Indicator	Three alligator clips , three flexible test probes, three test leads

Not available in all regions



Recommended accessories

<p>TLK290 Test probe kit</p>	<p>TLK291 Fused test probe set</p>	<p>C25 Large soft case</p>
------------------------------	------------------------------------	----------------------------



Receiver



Transmitter



Fluke 2042 Cable Locator

The multipurpose solution to cable location

The Fluke 2042 is a professional general purpose cable locator. It is ideal for tracing cables in walls and underground, locating fuses/breakers on final circuits and locating interruptions and shortcircuits in cables and electrical floor heating systems.

It can also be used for tracing metallic water and heating pipes. The unit is supplied as a complete kit comprising of a transmitter and receiver in a purposemade carry case. The receiver also incorporates a torch function for working in dimly lit locations.

- For all applications (live or dead cables) without additional instruments
- Set includes a transmitter and a receiver
- Proven digitally coded sender signal guarantees clear signal identification
- Transmitter with LCD-display for transmitting level, transmitting code and external voltage
- Receiver with a backlight LCD-display for level of receiving signal, code of receiving signal and live voltage indication
- Automatic or manual adjustment of receiving signal sensitivity
- Switchable acoustic receiving signal
- Auto-Power-Off
- Additional torch lamp function for working in dark environments
- Additional transmitters are available for extension or to distinguish between several signals

Specifications

	Transmitter	Receiver
Voltage Measurement Range	12V, 50V, 120V, 230V, 400V	
Frequency Range	0.60 Hz	
Output signal	125 kHz	
Voltage	Up to 400V ac/dc	
Tracing depth cable location	99 readings	0...2.5m wall/underground cables
Main voltage detection		0...0.4m

Ordering information

Models	Included accessories
FLUKE 2042 Cable Locator (transmitter + receiver)	TL27 heavy duty test lead set, TP74 lantern tip test probe set, AC285 alligator clip set, soft carrying case, hard case
FLUKE 2042T Cable Locator Transmitter	

*Not available in all regions



INDOOR AIR QUALITY TOOLS

Indoor Air Quality Tools

Tools to help you maintain good IAQ

Fluke 971 Temperature Humidity Meter

Temperature and humidity are two important factors in maintaining optimal comfort levels and good indoor air quality. Quickly and conveniently take accurate humidity and temperature readings with the Fluke 971. The Fluke 971 is invaluable for facility maintenance and utility technicians, HVAC-service contractors, and specialists who assess indoor air quality (IAQ). The Fluke 971 the perfect tool for monitoring problem areas. It is built to perform and made to last.

- New and improved digital sensor for faster response times
- Backlit dual display of humidity and temperature
- Measures dew point and wet bulb temperatures
- 99 record storage capacity
- Compact and lightweight at 188 g (6.6 oz)
- Min/Max/Avg/Hold functions

Specifications

Functions	Measurements
Temperature range	-20 °C to 60 °C (-4 °F to 140 °F)
Relative humidity range	5% to 95%
Temperature update rate	500 ms
Temperature sensor type	NTC
Response time (humidity)	For 90 % of total range - 60 sec. with 1 m/s air movement
Humidity sensor	Electronic capacitance polymer film sensor
Battery type	4 AAA alkaline batteries
Battery life	200 Hours
Safety approval	Electromagnetic compatibility: Complies with EN 61326-1



Fluke 985 Airborne Particle Counter

The Fluke 985 Particle Counter is ideal for troubleshooting and monitoring indoor air quality issues and verifying HVAC filter performance in critical locations, and is the perfect tool for the maintenance, HVAC, and IAQ professional.

- Six channels and particle size range of 0.3 µm to 10.0 µm
- Large 3.5 inch QVGA color display
- 10,000 record storage: Quick access to historical data
- On-screen data presentation
- Personalized setting and configurations
- Download data to a PC using a USB memory stick, USB cable or Ethernet connection
- USB/Ethernet charge cradle

Specifications

Functions	Measurements
Flow rate	2.83 L/min (0.1 cfm)
Light source	775 nm to 795 nm, 90 mW class 3B laser
Count modes	Raw counts, #/m ³ , #/ft ³ , #/liter in Cumulative or Differential mode
Counting efficiency	50 % @ 0.3 µm; 100 % for particles > 0.45 µm (per ISO 21501)
Zero count	1 count/5 minute (JIS B9921)
Concentration limits	10 % at 4,000,000 particles per ft ³ (per ISO 21501)
Sample inlet	Isokinetic probe
Operating environment	10 °C to 40 °C (50 °F to 104 °F)/< 95 % non-condensing relative humidity
Warranty	One-year

Ordering information

Models	Included accessories
FLUKE-985 Airborne Particle Counter	Certificate of Calibration (NIST traceable), cradle for charging and convenient USB and Ethernet communications, ethernet cable, USB cable, power supply, zero count inlet filter, filter adapter, sample inlet protective cap, hard case, manual
FLUKE-971 Temperature Humidity Meter	Four AAA alkaline batteries, users manual

Monitor air humidity levels throughout your facility with the Fluke 971.



INDOOR AIR QUALITY TOOLS



Fluke 975 AirMeter™

Simple, all-in-one air diagnostics

The Fluke 975 AirMeter™ combines five powerful air quality tools into one.

- Simultaneously measures, logs and displays temperature, humidity, CO₂ and CO
- % of outside air calculation, one-touch air flow and velocity with available probe (975V)
- Dew point and wet bulb temperature
- CO₂ and CO field calibration feature
- Min/Max/Avg on all measured and calculated readings, audible and visual threshold alarms
- Discrete or continuous data logging capacity, downloadable to PC via USB interface
- Automatically compensates for barometric pressure changes
- Two-year warranty

Specifications

	Range	Display resolution	Accuracy
Temperature	-20 °C to 50 °C (-5 °F to 122 °F)	0.1 °C (0.1 °F)	± 0.9 °C/± 1.62 °F from 40 °C to 60 °C ± 0.5 °C/± 1.00 °F from 5 °C to 40 °C ± 1.1 °C/± 1.98 °F from -20 °C to 5 °C
Relative humidity	10% to 90% RH non-condensing	1 %	± 2 % RH (10% RH to 90% RH)
Air velocity	50.0 fpm to 3000 fpm 0.25 m/s to 15 m/s	1 fpm (0.005 m/s)	± 4 % or 4 fpm* ± 4 % or 0.02 m/s* whichever is greater * Accuracy specification only valid for velocity readings above 0.25 m/s
CO ₂	0 ppm to 5000 ppm	1 ppm	Warm up time 1 min (5 minutes for full specification) 2.75 % + 75 ppm
CO	0 ppm to 500 ppm	1 ppm	± 5 % or ± 3 ppm, whichever is greater, @ 20 °C and 50% RH



Fluke 922 Airflow Meter/Micromanometer

The Fluke 922 makes your job easier by combining differential pressure, airflow and velocity into a single, rugged meter.

- Measures differential and static pressure, air velocity and flow readings
- User-defined duct shape and size for maximum airflow accuracy
- Min/Max/Avg/Hold functions

Specifications

	Range	Accuracy
Air pressure	± 4000 Pascals/± 16 in H ₂ O/± 400 mm H ₂ O/ ± 40 mbar/± 0.6 PSI	± 1 % + 1 Pascal/± 1 % + 0.01 in H ₂ O/ ± 1 % + 0.1 mm H ₂ O/± 1 % + 0.01 mbar/ ± 1 % + 0.0001 PSI
Air velocity	250 fpm to 16,000 fpm (1 to 80 m/s)	± 2.5 % of reading at 2000 fpm (10.00 m/s)
Air flow (volume)	0 to 99,999 cfm; 0 to 99,999 m ³ /hr; 0 to 99,999 l/s	Accuracy is a function of velocity and duct size
Temperature	0 °C to 50 °C (32 °F to 122 °F)	0.1 °C (0.1 °F)
Data storage	99 readings	

Fluke RLD2 UV Refrigerant Leak Detector Flashlight

Flashlight that uncovers refrigerant leaks instantly. Laser pointer to find exact leak location.

CO-220 Carbon Monoxide Meter

Check CO levels around furnaces and boilers. Tracks increasing frequency as CO levels rise.

CO-205 Aspirator Kit

A flue gas sampling accessory kit.

Ordering information

Models	Included accessories
FLUKE-975V AirMeter™ with Velocity	Calibration cap, air velocity probe (Fluke 975V only), FlukeView® Forms software, power adapter, international power plugs, hard carrying case, three AA alkaline batteries, users manual with safety information
FLUKE-975 AirMeter™	
FLUKE-922 Airflow Meter	Two rubber hoses, soft carrying case, four AA alkaline batteries 1.5 V, users manual
FLUKE-922/Kit Airflow Meter Kit	12 inch pitot tube, two rubber hoses, magnetic hanging strap, four AA alkaline batteries, users manual, hard carrying case
FLUKE-RLD2 Refrigerant Leak Detector Flashlight	
FLUKE-CO-220 Carbon Monoxide Meter	
FLUKE-CO-205 Aspirator Kit	



Fluke 1000FLT Fluorescent Light Tester

Take the trial and error out of fluorescent light testing

Save time and reduce costs by using the only tester that performs all five essential lighting tests in less than 30 seconds. The Fluke 1000FLT fluorescent light tester makes your job easier by quickly pinpointing problems and verifying operation of fluorescent lights and fixtures. It is easy to use and can survive on-the-job handling, including a two meter drop. Like all Fluke products, the 1000FLT is built to last, easy to maintain and is backed by a three-year warranty. Companies have made significant investments in fluorescent lighting; if your job requires keeping large numbers of these fluorescent lights shining, the Fluke 1000FLT is an indispensable tool.

- **Lamp test:** Test bulb without removing from fixture
- **Ballast test:** Easily determine if ballast is working
- **Non-contact voltage:** Quickly check for voltage presence
- **Pin continuity test:** Tests if filaments have continuity
- **Ballast-type test:** Determine if ballast is electronic or magnetic without taking fixture apart—identify energy wasting ballasts

Specifications

Functions	Measurements
Lamp test max output	3000 V peak-to-peak
Ballast test	20 kHz
Ballast type discriminator	≤3 m (10 ft) distance
Pin continuity test	< 1 kΩ
NCV (VoltAlert™)	85 V ac to 277 V ac
	45 Hz to 67 Hz
Operating temperature	-10 °C to +50 °C (14 °F to +122 °F)
Storage temperature	Storage -40 °C to +60 °C (-40 °F to +140 °F)
Safety rating	IEC 61010-1, pollution degree 2
Warranty	Three-year

Ordering information

Models	Included accessories
FLUKE-1000FLT Fluorescent Light Tester	Quick reference guide, 4 AA alkaline batteries, holster



Quickly check for voltage presence without touching a live conductor.

Easily determine if ballast is working.



INSULATION TESTERS



Fluke 1587 FC/1577 Insulation Multimeters

The High-Performance 2-in-1 Insulation DMM

The Fluke 1587 FC and 1577 Insulation Multimeters combine a digital insulation tester with a full-featured, true-rms digital multimeter in a single compact, handheld unit, which provides maximum versatility for both troubleshooting and preventive maintenance.

The Fluke 1587 FC Insulation Multimeter adds four powerful new diagnostic functions through the Fluke Connect® Measurements app:

- PI/DAR timed ratio tests with TrendIt™ graphs identifies moisture and contaminated insulation problems faster
- Memory storage through Fluke Connect eliminates writing down results, reduces errors and saves data for historical tracking over time
- Temperature Compensation through app for establishing accurate baselines and relevant historical comparisons
- Historical tracking and trending of assets identifies degradation over time, allows real-time decisions to be made in the field with Fluke Connect® Assets (sold separately)

Specifications

	1587 FC	1577
PI/DAR timed ratio measurements with TrendIt™ graphs through Fluke Connect Measurements app	•	
Memory storage through Fluke Connect Measurements app	•	
Temperature Compensation through Fluke Connect Measurements app	•	
Insulation test voltages 50 V, 100 V, 250 V, 500 V, 1000 V	•	
Insulation test voltages 500 V, 1000 V		•
Insulation resistance	0.01 MΩ to 2.0 GΩ	0.1 MΩ to 600 MΩ
Auto-discharge of capacitive voltage	•	•
Insulation test smoothing reading	•	
Frequency	•	
Capacitance	•	
Diode test	•	
Temperature	•	
Min/Max	•	
VFD low-pass filter for accurate motor drive measurements	•	
AC/DC voltage	•	•
DC millivolts	•	•
AC/DC milliamps	•	•
Resistance	0.1 Ω to 50 MΩ	0.1 Ω to 50 MΩ
Continuity	•	•
Auto power off	•	•
Warranty (years)	3	3

Ordering information

Models	Included accessories
FLUKE-1587 FC Insulation Multimeter	Remote probe, test leads, alligator clips, K-type thermocouple, hard case, users documentation
FLUKE-1577 Insulation Multimeter	Remote probe, test leads, alligator clips, hard case, users documentation

Troubleshooting efficiency and maximum versatility while testing motors and VSDs accurately with Low-Pass filter.



Kits—buy more, save more



Fluke 1587 KIT/62MAX+ FC
Advanced Electrical Troubleshooting Kit



Fluke 1587/MDT FC
Advanced Motor and Drive Troubleshooting Kit

Recommended accessories



TLK289 Industrial Master
Test Lead Set



i400 AC Current
Clamp

Fluke 1507 and 1503 Insulation Resistance Testers

The quality, durability, and convenience you need

These lightweight, affordable insulation testers are perfect for troubleshooting, commissioning and preventive maintenance applications.

- Automatic calculation of polarization index and dielectric absorption ratio (1507 only)
- Multiple test voltages: 50 V, 100 V, 250 V, 500 V, 1000 V (1507 only)
- Remote test probe for rapid testing
- Insulation test range 0.01 MΩ to 10 GΩ (1507), 0.1 MΩ to 2 GΩ (1503)
- Compare (Pass/Fail) function for repetitive tests (1507 only)
- Live circuit detection prevents insulation test if voltage > 30 V is detected
- Auto-discharge of capacitive voltage
- AC/DC voltage: 0.1 V to 600 V
- Lo ohms/Earth-bond continuity (200 mA) for checking connections and motor windings
- Resistance: 0.01 Ω to 20.00 kΩ



Specifications

	1507	1503
Insulation test voltages 50 V, 100 V, 250 V, 500 V, 1000 V	•	•
Insulation test voltages 500 V, 1000 V		•
Insulation resistance	0.01 MΩ to 10 GΩ	0.1 MΩ to 2 GΩ
Auto-discharge of capacitive voltage	•	•
Continuity function	200 mA acc. EN 61557-4	
Resistance	0.1 Ω to 20.00 kΩ	0.1 Ω to 20.00 kΩ
Auto power off	•	•
Warranty (years)	1	1

Ordering information

Models	Included accessories
FLUKE-1507 Insulation Tester	Remote probe, silicone test leads, test probes, large alligator clips, holster, users manual
FLUKE-1503 Insulation Tester	Remote probe, silicone test leads, test probes, large alligator clips, holster, users manual



Magnetic Meter Hanger frees up both hands to focus on making measurements safely.

Check connections and motor windings with Lo ohms/earth-bond continuity test.



Recommended accessories

<p>TLK289 Industrial Master Test Lead Set</p>	<p>TL27 Heavy Duty Test Lead Set</p>	<p>C116 Soft Carrying Case</p>	<p>C101 Hard Case</p>
--	---	---------------------------------------	------------------------------

INSULATION TESTERS



1555 and 1550C Insulation Resistance Testers

Powerful troubleshooting and predictive maintenance tools

The Fluke 1555 and Fluke 1550C Insulation Resistance Testers offer digital insulation testing up to 10 kV, making them ideal for testing a wide range of high voltage equipment including switchgear, motors, generators and cables.

- Test voltages up to 5 kV (1550C) and 10 kV (1555) provide solutions for all applications
- Warning function alerts the user that line voltage is present and gives a voltage reading up to 600 V ac or dc for increased user safety
- Measurements can be stored in up to 99 memory locations, and each location is assigned a unique, user-defined label for easy recall
- Automatic calculation of Dielectric Absorption (DAR) and Polarization Index (PI) with no additional setup
- Guard system eliminates the effect of surface leakage current on high-resistance measurements
- Capacitance and leakage current measurement
- Ramp function for breakdown testing

Selection guide

	1555	1550C
Insulation test voltages: User selectable 250 V to 5000 V		•
Insulation test voltages: User selectable 250 V to 10,000 V	•	
Insulation resistance	2 TΩ	1 TΩ
Auto-discharge of capacitive voltage	•	•
Warranty (years)	3	3

Specifications

Test voltage (dc)	Range	Accuracy (± reading)
250 V	< 250 kΩ	unspecified
	250 kΩ to 5 GΩ	5 %
	5 GΩ to 50 GΩ	20 %
	> 50 GΩ	unspecified
500 V	< 500 kΩ	unspecified
	500 kΩ to 10 GΩ	5 %
	10 GΩ to 100 GΩ	20 %
	> 100 GΩ	unspecified
1000 V	< 1 MΩ	unspecified
	1 MΩ to 20 GΩ	5 %
	20 GΩ to 200 GΩ	20 %
	> 200 GΩ	unspecified
2500 V	< 2.5 MΩ	unspecified
	2.5 MΩ to 50 GΩ	5 %
	50 GΩ to 500 GΩ	20 %
	> 500 GΩ	unspecified
5000 V	< 5 MΩ	unspecified
	5 MΩ to 100 GΩ	5 %
	100 GΩ to 1 TΩ	20 %
	> 1 TΩ	unspecified
10000 V (1555 only)	< 10 MΩ	unspecified
	10 MΩ to 200 GΩ	5 %
	200 GΩ to 2 TΩ	20 %
	> 2 TΩ	unspecified
Functions		
Leakage current	1 nA to 2 mA	± (20% + 2 nA)
Capacitance measurement	0.01 µF to 20.00 µF	± (15% rdg + 0.03 µF)
Live circuit indicator	30 V to 1100 V ac/dc, 50/60 Hz	±(15% + 2 V)

Flexibility for testing wide range of high voltage applications.



Ordering information

Models	Included accessories
FLUKE-1550C 5 kV Insulation Tester	Test leads with alligator clips, infrared adapter with interface cable, FlukeView Forms software, ac power cord, soft carrying case, quick reference guide, users manual
FLUKE-1555 10 kV Insulation Tester	
FLUKE-1550C KIT	Test leads with ruggedized alligator clips, infrared adapter with interface cable, FlukeView Forms software, AC power cord, hard carrying case, quick reference guide, users manual, NIST traceable certificate
FLUKE-1555 KIT	

Power quality and energy tools selection guide

Basic measurements	Application use	Single-Phase			Three-Phase					
		VR1710	345	43B	1730	1736/38	1740	430-II	1750	1760
Energy studies										
Measure V, I, kW, Cos/DPF, kWhr	Get detailed power and energy consumption profiles during energy audits and pinpoint savings opportunities		•	•	•	•	•	•	•	•
Measure MIN/MAX and AVG values			•	•	•	•	•	•	•	•
10 day logging			•	•	•	•	•	•	•	•
Waste energy monetization								•		
Basic harmonics study										
THD measurement (V & I)	Discover the source of distortion in your installation, so that you can filter those loads or move them to separate circuits	•	•	•	•	•	•	•	•	•
Harmonics 1 to 25 for V & I		(V only)	•	•		•	•	•	•	•
Advanced harmonics study										
Full harmonic spectrum	If distorting loads are causing problems in your installation, you need comprehensive data to identify the source and create a solution		•	•		•	•	•	•	•
Power harmonics			•	•				•	•	•
Basic industrial PQ troubleshooting										
Oscilloscope function	When troubleshooting in the field, graphical data enables you to trace the source of the problem at hand		•	•		•		•	•	•
Voltage dips and swells		•		•		•	•	•	•	•
Advanced industrial PQ troubleshooting										
Comprehensive logging capability	Complex installations often require a deeper dive into measurement data. Multiple loads may be interacting randomly to cause a single problem		•	•		•	•	•	•	•
Transient capture		•		•		•		•	•	•
Flicker		•					•	•	•	•
Motor analysis										
Speed	Perform dynamic motor analysis by plotting of motor de-rating factor against load according to NEMA/IEC guidelines on direct on-line electric motors							•		
Torque								•		
Mechanical power								•		
Efficiency								•		
Features										
Inrush						•		•		
Flicker								•	•	•
Transients								•	•	•
Mains signaling								•	•	•
Power wave								•		
Event waveform capture						•		•	•	•
400 Hz								•		
Power inverter efficiency								•		



Fluke 430-II Series Three-Phase Power Quality and Motor Analyzers



Locate, predict, prevent power quality problems

The Fluke 434-II, 435-II, 437-II and 438-II help troubleshoot power quality problems in three- and single-phase power distribution systems. The Fluke patented energy loss algorithm, Unified Power Measurement, measures, quantifies and monetizes energy losses due to harmonics and unbalance issues, allowing the user to pinpoint the origin of energy waste within a system.

- Capture fast rms data in real time with PowerWave data capture; show single cycle rms value to characterize electrical system dynamics (generator start-ups, UPS switching etc.)
- Measure key parameters on direct-on-line motors including torque, RPM, mechanical power and motor efficiency (438-II, or with 430-II/MA upgrade option)
- CAT IV 600 V/CAT III 1000 V rated for use at the service entrance
- Automatic transient mode; capture 200 kHz waveform data on all phases simultaneously up to 6 kV for 435-II and 437-II
- Conduct tests according to the stringent international IEC 61000-4-30 Class-A standard intervals for 435-II and 437-II
- With included four iFlex flexible current probes, measure all three phases and neutral
- Download data wirelessly with the Fluke Connect® SD Card (not included with the INTL)
- Three-year warranty

ENERGY LOSS CALCULATOR			
Due to Load Current	Loss	Cost/yr	
Effective	323 kJ	740 U	58¢
Reactive	164 kvar	193 U	15¢
Unbalance	170 kVA	190 U	15¢
Distortion	598 kVA	2.52 kJ	180¢
Neutral	51.7 kA	3.08 U	2.2¢
Line loss	3.66 kJ	270¢	

Ordering information

Models	Included accessories
FLUKE-434-II Three-Phase Energy Analyzer	
FLUKE-435-II Three-Phase Power Quality and Energy Analyzer	Four thin flexible current probes, five test leads and clips, battery charger, Power Log software, USB cable, color localization set, soft carrying case, 8GB WiFi SD memory card, users manual on CD
Fluke-438-II Three-Phase Power Quality and Motor Analyzer	
FLUKE-437-II 400 Hz Three-Phase Power Quality and Energy Analyzer	Four thin flexible current probes, five test leads and clips, battery charger, Power Log software, USB cable, color localization set, hard carrying case with wheels, 8GB WiFi SD memory card, users manual on CD
Fluke-430-II/MA 430-II Motor Analyzer Upgrade Kit	Firmware license code

Fluke 1730 Three-Phase Electrical Energy Logger

Find sources of energy waste

The Fluke 1730 Three-Phase Electrical Energy Logger introduces a new simplicity to discovering sources of electrical energy waste. Profiling energy usage across your facility helps you identify opportunities for energy savings and provides you with the easy-to-understand data. The Fluke 1730 Energy Logger can be used for conducting energy surveys that require both a voltage and current connection. Load studies that require a current connection only for evaluating electrical demand capacity can also be performed.

- Quickly understand specific points of energy loss, reduce energy bills more easily than ever
- Optimized layout with specialized touch screen makes navigation easy—even with gloves on
- Advanced auto-correct feature eliminates costly errors due to improper connections
- Power directly from the measured voltage line (up to 500 V) or with conventional ac power cord

Ordering information

Models	Included accessories
1730/BASIC Three-Phase Electrical Energy Logger (excludes current probes)	Power supply, voltage test lead, dolphin clip, i1730-flex 1500 iFlex Flexible Current Probes, color-coded wire clips, power cord, test lead set with stackable plugs, dc power cable(s), USB cable A, mini USB, soft storage bag, input connector decal, information packet. Software included
1730/US Portable Energy Logger US version	Software included (FEA, Fluke Energy Analyze)
1730/EU Portable Energy Logger EU version	
1730/INTL Portable Energy Logger ITNL version	
FLUKE-1735 Three-Phase Power Logger	Four flexible current probes (15 A/150 A/3000 A), Power Log software, voltage leads and clips, color localization set, PC interface cable, international ac adapter (115 V/230 V, 50 Hz/60 Hz), soft carrying case, users manual, multi-language manual on CD

See our **NEW** products on page 9!



Fluke 1736 and 1738 Three-Phase Power Loggers

More visibility, reduced uncertainty and better power quality and energy consumption decisions

The Fluke 1736 and 1738 Three-Phase Power Loggers built with Fluke Connect® mobile app and desktop software compatibility give you the data you need to make critical power quality and energy decisions in real-time. The ideal test tools for conducting energy studies and basic power quality logging, the 1736 and 1738 automatically capture and log over 500 power quality parameters so you have more visibility into the data you need to optimize system reliability and savings.

- **Measure all three phases and neutral** with included four flexible current probes.
- **Comprehensive logging:** More than 20 separate logging sessions can be stored on the instruments. In fact, all measured values are automatically logged so you never lose measurement trends.
- **Capture dips, swells, and inrush currents:** includes event waveform (1738 only) snapshot and high resolution RMS profile, along with date, timestamp and severity to help pinpoint potential root causes of power quality issues.
- **Optimized user interface:** Capture the right data every time with quick, guided, graphical setup and reduce uncertainty about your connections with the intelligent verification function.
- **Fluke Connect® Compatible:** View data locally on the instrument, via Fluke Connect mobile app and desktop software or through your facilities' WiFi infrastructure



Specifications

Accuracy				
Parameter		Range	Resolution	Intrinsic accuracy at reference conditions (% of reading + % of full scale)
Voltage		1000 V	0.1 V	± (0.2% + 0.01%)
Current: Direct input	i17xx-flex 1500 12"	150 A	0.1 A	± (1% + 0.02%)
		1500 A	1 A	± (1% + 0.02%)
	i17xx-flex 3000 24"	300 A	1 A	± (1% + 0.03%)
		3000 A	10 A	± (1% + 0.03%)
	i17xx-flex 6000 36"	600 A	1 A	± (1.5% + 0.03%)
		6000 A	10 A	± (1.5% + 0.03%)
	i40s-EL clamp	4 A	1 mA	± (0.7% + 0.02%)
		40 A	10 mA	± (0.7% + 0.02%)
Frequency		42.5 Hz to 69 Hz	0.01 Hz	± (0.1%)
Aux input		± 10 V dc	0.1 mV	± (0.2% + 0.02%)

¹Range = 1000 V x Irange

Ordering information

Models	Included accessories
FLUKE-1736 Three-Phase Power Logger	Instrument, power supply, voltage test leads, alligator clips (4x), 12 in 1,500 A flexible current probe (4x), soft case, Energy Analyze Plus software, WiFi adapter**, line cords, color coding set and documentation on USB flash drive
FLUKE-1738 Three-Phase Power Logger	Instrument, power supply, voltage test leads, alligator clips (4x), 12 in 1,500 A flexible current probe (4x), soft case, Energy Analyze Plus software, magnetic hanging strap, magnetic voltage probes (4x), WiFi/BLE adapter**, line cords, color coding set and documentation on USB flash drive
FLUKE-1738/Upgrade	Magnetic hanging strap, magnetic voltage probes (4x), WiFi/BLE adapter, Firmware license: PQ Health, Wave form Event Capture

**Not all models are available in all countries. Check with your local Fluke representative.



POWER QUALITY AND ENERGY TOOLS



Fluke 345 Power Quality Clamp Meter

Troubleshoot modern electrical loads

The Fluke 345 is more than a power meter. Combining the functions of a clamp meter, oscilloscope, data logger and digital power meter into one handy device. The Fluke 345 is ideal for working with variable frequency motor drives, high efficiency lighting and other loads using switching electronics.

- Clamp-on measurement of ac current up to 1400 A rms and dc current up to 2000 A without breaking the circuit
- CAT IV 600 V power analyzer is rated for use at the service entrance
- Clamp meter performs even in noisy environments with distorted waveforms present on electronic loads with low-pass filter
- Identify intermittent faults by logging any power quality parameter for minutes, or over a month, including harmonics
- Analyze, log and troubleshoot harmonics digitally or graphically
- Capture and analyze inrush current and nuisance tripping from 3 seconds to 300 seconds
- View graphs and generate reports using power analyzer with included Power Log software



Fluke 43B Power Quality Analyzer

Measurements to maintain power systems

The Fluke 43B Power Quality Analyzer troubleshoots power problems and diagnoses equipment failures. The 43B has 20 storage locations and can store data as well as screens.

- Voltage, current and power harmonics up to 51st, THD
- View voltage and current waveforms with the oscilloscope function
- Capture up to 40 voltage transients and waveform events
- Cursors give time and date of sags and swells for detailed event capture
- Analysis and reporting with FlukeView® software, supplied with USB connection lead
- Three-year warranty for analyzer, one-year warranty for accessories



Fluke VR1710 Power Quality Recorder

- Fast and easy recording of voltage trends, dropouts and power quality to easily pinpoint the root cause of single phase voltage problems
- Min, Max, and Average RMS values (1/4 cycle) with time stamp, transient display (>100 µs) with time stamp
- Identify problems with power quality or equipment related Flicker recording to EN 61000-4-15, individual harmonic and THD values with trends
- Includes PowerLog software for quick download, analysis and automatic reporting
- Generate power quality reports automatically with pre-set templates



Ordering information

Models	Included accessories
FLUKE-345 Clamp-On Power Meter	Test leads, alligator clips, test probes, Power Log software, USB cable, international ac adapter/battery eliminator, soft carrying case, users manual, multi-language manual on CD
FLUKE-43B Power Quality Analyzer	Voltage and current probes, FlukeView® software, power quality instructional CD, USB interface cable, line voltage adapter/battery charger, hard case, users manual
FLUKE-VR1710 Voltage Quality Recorder	USB cable, Power Log software CD, universal power cord adapters

Fluke Norma 4000 and 5000 Precision Power Analyzers

For field and laboratory testing

Fluke Norma 4000 and 5000 Precision Power Analyzers offer easy and straight-forward operation with unmatched price performance. Features include: 1 to 6 power phases, 144 mm (5.7 in) color display, harmonic analysis, scope mode, vector diagram display, recorder function, Fluke NormaView PC software and 4MB RAM data memory.

- A variety of standard configurations allows users to choose the exact functionality required for their unique application
- Inputs are galvanically isolated to avoid short circuits in all applications, and simultaneous parallel acquisition of all phases allows for accurate viewing of dynamic events dc to 3 MHz/10 MHz bandwidth for reliable measurement precision
- Voltage, current and power harmonics FFT analysis to the 40th harmonic, vector diagram, and Digital Oscilloscope (DSO) mode included in the base unit
- PII process interface to measure torque and speed with external sensors, plus four analog outputs for easy use on motor and drive applications
- Data download, analysis and report writing with supplied Fluke NormaView PC software



Fluke Norma 4000



Fluke Norma 5000



Fluke 1745



Fluke 1744/1743

Fluke 1740 Series Three-Phase PQ Loggers

Instruments to troubleshoot and analyze power distribution

The Fluke 1740 Series Three-Phase Power Quality Loggers include PQ Log software to quickly assesses the quality of power at the service entrance, substation, or at the load, according to the latest EN50160 standard.

- Setup in minutes with automatic current probe detection and powering
- Compact, fully-insulated housing and accessories fit easily in tight spaces, next to live power
- Included PQ Log software analyzes trends, creates statistical summaries, and generates detailed graphs and tables
- IEC61000-4-30 Class-A compliant voltage accuracy (0.1%)

Specifications

	1743/1744	1745	1750
Measures common power parameters: V, A, W, VA, VAR, PF, energy, flicker, voltage events, and THD	•	•	•
Measures voltage and current harmonics to the 50th, unbalance, and mains signaling	•	•	•
Transient capture			•
PDA support			•
UPS ride through	3s	> 5 hours	5 min per interruption, 60 min total
Dimensions	170 mm x 125 mm x 55 mm (6.9 in x 5.1 in x 2.2 in)	282 mm x 216 mm x 74 mm (11.5 in x 8.8 in x 3 in)	215 mm x 310 mm x 35 mm (8.5 in x 12.2 in x 3.5 in)
Weight (approx.)	0.9 kg (2 lb)	1.4 kg (3 lb)	6.3 kg (14 lb)

Ordering information

Models	Included accessories
Norma 4000 High Precision Power Analyzer	Power supply cable, NormaView PC software, test certificate, calibration values, users manual
Norma 5000 High Precision Power Analyzer	Power supply cable, NormaView PC software, test certificate, calibration values, users manual
FLUKE-1745 Power Quality Logger – Memobox	Four flexible probes 15/150/1500/3000 A with 2 m cable, PQ Log software, RS-232 interface cable and USB adapter, four dolphin clips, test leads for voltages and power supply, color localization kit, carrying bag, test certificate with measurement values, users manual, multi-language manual CD
FLUKE-1744 Power Quality Logger – Memobox	Four flexible probes 15/150/1500/3000 A with 2 m cable, PQ Log software, RS-232 interface cable and USB adapter, four dolphin clips, test leads for voltages and power supply, color localization kit, carrying bag, test certificate with measurement values, users manual, multi-language manual CD
FLUKE-1743 Power Quality Logger – Memobox	Four flexible probes 15/150/1500/3000 A with 2 m cable, PQ Log software, RS-232 interface cable and USB adapter, four dolphin clips, test leads for voltages and power supply, color localization kit, carrying bag, test certificate with measurement values, users manual, multi-language manual CD

In the U.S., these power quality recorders are sold exclusively through power quality representatives.





Fluke 1750 Three-Phase Power Recorder

Never miss capturing a disturbance

The Fluke 1750 Power Recorder and the Fluke Power Analyze software allows you to easily record three-phase power quality and monitor for power quality disturbances. These power meters automatically record every power quality parameter and event, on every cycle—all the time.

- All measurements comply with IEC61000-4-30 standards for correct evaluation of all measured values including voltage, current, power, harmonics, flicker etc.
- PDA wireless “front panel interface” provides a window into what the instrument is recording, enabling quick and reliable configuration even in awkward test locations
- Cross-channel and current triggering capture every measurement, on every channel, every time
- With intuitive PC software, easily analyze data and generate reports. Automated EN50160 reporting and compliance
- Voltage and current measurements on three phases, neutral and ground



Fluke 1760 Three-Phase Power Quality Recorder

Captures the most comprehensive details

The Fluke 1760 Three-Phase Power Quality Recorder is fully compliant to IEC 61000-4-30 Class-A, for advanced power quality analysis and consistent compliance testing. Designed for analysis of utility and industrial power distribution systems, in medium- and low-voltage networks, this power quality monitor provides the flexibility to customize thresholds, algorithms, and measurement selections.

- Use GPS time synchronization to correlate data with events or datasets from other instruments with precision
- Using flexible and fully configurable thresholds and scale factors, pinpoint specific issues by defining the detailed criteria for detection and recording of disturbances
- 10 MHz, 6000 Vpk waveform capture for a detailed picture of even the shortest event
- 2GB data memory enables detailed, simultaneous recording of numerous power parameters for long periods of time
- Comprehensive software provides trend diagrams for root cause analysis, statistical summaries, report writing and real-time data monitoring in the online mode
- Quick setup with automatic sensor detection; sensors are instrument powered, eliminating the need for batteries

Specifications

	1760TR	1760	1760TR BASIC	1760 BASIC
Online mode (oscilloscope, transients and events)	•	•	•	•
Fast transient analysis up to 10 MHz	•		•	
Four 600 V voltage probes	•	•		
Four dual-range flexible current probes (1000 A/200 A ac)	•	•		
GPS time sync receiver	•	•		

Ordering information

Models	Included accessories
FLUKE-1750 Three-Phase Power Recorder Kit	Acquisition unit, PDA and charger, power plug adapters, 4 x 400 A 3140-PR current probes (1750 only), 4 x 1000 A 3210-PR-TF iFlex current probes (1750-TF only), five test leads and clips, SD memory card, Fluke Power View and Fluke Power Analyze software, power cord with international plug set, ethernet cable, color localization set, users manual and CD
FLUKE-1750-B Three-Phase Power Recorder Basic Kit	
FLUKE 1750-TF Three-Phase Power Recorder Kit	
FLUKE-1760 Three-Phase Power Recorder	Acquisition unit, voltage and current probes (1760, 1760TR), GPS time sync receiver (1760TR, 1760TR Basic) Fluke PQ Analyze software, power cord with international plug set, ethernet cable, color localization set, users manual and CD
FLUKE-1760 Basic Three-Phase Power Recorder	
FLUKE-1760TR Three-Phase Power Recorder	
FLUKE-1760TR Basic Three-Phase Power Recorder	

In the U.S., these power quality recorders are sold exclusively through power quality representatives.



Fluke BT500 Series Battery Analyzers

Reduced testing complexity, a simplified workflow and an intuitive user interface provide a new level of ease-of-use in battery testing

The new Fluke BT500 Series Battery Analyzer is ideal test tool for maintenance, troubleshooting and performance testing of individual stationary batteries and battery banks used in critical battery back-up applications. Fluke BT500 Series Battery Analyzers cover a broad range of battery test functions ranging from dc voltage and resistance tests to full condition testing using an automated string function testing and the test probe integrated infrared temperature measurement system. BT500 Series Battery Analyzers are designed for measurements on stationary batteries of all types.

- **Key measurements:** Battery resistance, dc and ac voltage, dc and ac current, ripple voltage, frequency and battery temperature
- **Sequence measurement mode:** Automatic or manual sequence testing of battery strings with automatic measurement storage including voltage, resistance and temperature (with BTL21 intelligent test probe)
- **Comprehensive logging:** All measured values are automatically captured during testing and can be reviewed on the instrument before downloading for on-the-go analysis
- **Optimized user interface:** Quick, guided setup ensures the right data is captured every time, and the combined visual and audio feedback cues reduce the risk of measurement confusion
- Safety CAT III 600 V

Specifications

Functions	Range	Resolution	Accuracy	BT510	BT520	BT521
Battery resistance ¹	3 mΩ	0.001 mΩ	1% + 8	•	•	•
	30 mΩ	0.01 mΩ	0.8% + 6	•	•	•
	300 mΩ	0.1 mΩ	0.8% + 6	•	•	•
	3000 mΩ	1 mΩ	0.8% + 6	•	•	•
V dc	6 V	0.001 V	0.09% + 5	•	•	•
	60 V	0.01 V	0.09% + 5	•	•	•
	600 V	0.1 V	0.09% + 5	•	•	•
	1000 V	1 V	0.09% + 5	•	•	•
V ac (45 Hz to 500 Hz with 800 Hz filter)	600 V	0.1 V	2% + 10	•	•	•
Frequency (displayed with V ac and A ac) ²	500 Hz	0.1 Hz	0.5% + 8	•	•	•
AC voltage ripple (20 KHz Max)	600 mV	0.1 mV	3% + 20	•	•	•
	6000 mV	1 mV	3% + 10	•	•	•
A dc/A ac (with accessory Fluke i410)	400 A	1 A	3.5% + 2			•
Temperature	0 °C to 60 °C	1 °C	2 °C (4 °F)			•
Meter mode	999 records for each measurement position with time stamp					
Sequence mode	Up to 100 profiles and 100 profile templates (Each profile stores up to 450 batteries) with time stamp					

¹The measurement is based on AC injection method. The injected source signal is < 100 mA, 1 kHz.

²Trigger level V ac: 10 mV, A ac: 10 A.

Ordering information

Models	Included accessories
FLUKE-BT521 Advanced Battery Analyzer	4-wire test pin (set), test lead (set), test leads with adapter, test probe set with extender and temperature sensor, ac/dc current clamp, lithium-ion battery, ac charger, mini-USB cable, shoulder strap, belt strap, magnetic hanging strap, software, soft carrying case, spare fuses (2), battery tags, and zero ohm calibration resistor
FLUKE-BT520 Battery Analyzer	4-wire test pin (set), test lead (set), test leads with adapter, test probe set with extender (no temperature sensor), lithium-ion battery, ac charger, mini-USB cable, shoulder strap, belt strap, magnetic hanging strap, software, soft carrying case, spare fuses (2), battery tags, and zero ohm calibration resistor
FLUKE-BT510 Battery Analyzer	4-wire test pin (set), test lead (set), test leads with adapter, lithium-ion battery, ac charger, mini-USB cable, shoulder strap, belt strap, magnetic hanging strap, software, soft carrying case, spare fuses (2), and zero ohm calibration resistor



Measure impedance with the Fluke BT521 Battery Analyzer.



PROCESS TOOLS SELECTION GUIDE

Models	Process mA Clamp Meter 773	ProcessMeter® Test Tool 789	Loop Calibrator 709H	Pressure Calibrator 719/719PRO	Temperature Calibrator 724	Precision Multifunction Process Calibrator 726	Intrinsically Safe Calibrator 725Ex	Documenting Process Calibrator 754
Measure								
V dc	30 V	1000 V	30 V		30 V	30 V	30 V	300 V
V ac (true-rms)		1000 V						300 V
Resistance		40 MΩ			3200 Ω	4000 Ω	3200 Ω	11 kΩ
A dc max	20.99, 99.9 mA	30 mA, 1 A	24 mA	24 mA	24 mA	24 mA	24 mA	110 mA
A ac max		•						
Frequency		20 kHz				15 kHz	10 kHz	50 kHz
Pressure				2 bar, 10 bar, 20 bar		• ¹	• ³	• ¹
Temperature: RTDs				719Pro optional	7 types	8 types	7 types	8 types
Temperature: TCs					12 types	13 types	12 types	13 types
Source/Simulate								
V dc	10 V				10 V	20 V	10 V	15 V
Resistance					3200 Ω	4000 Ω	3200 Ω	11 kΩ
mA dc	24 mA	24 mA	24 mA	24 mA		24 mA	24 mA	22 mA
mA source; auto step, auto ramp	•	•	•	•		•	•	•
Frequency						15 kHz	10 kHz	50 kHz
Temperature: RTDs					7 types	8 types	7 types	8 types
Temperature: TCs					12 types	13 types	12 types	13 types
Record								
Min/Max		•		•				•
Hold	•	•		719				•
As found/As left results								•
Log data			•					•
Upload data to PC			•					•
Remote operation		•				•		
Features								
24 V loop supply	•	•	•	•	•	•	12 V	26 V
Non-contact mA measurement	•							
HART communication			•					•
Intrinsically safe (ATEX)							•	
Traceable calibration certification			•	•	•	•	•	•
Pressure enabled ²				•		•	• ³	•
Warranty (years)	3	3	3	3	3	3	3	3

¹Fluke 750P Pressure Modules required.

²Fluke Process Calibrators in this guide displaying the Pressure Enabled symbol display readings from the 750P Series Pressure Modules.

³Fluke 700PEX Pressure Module required.

Fluke 771, 772 and 773 mA Process Clamp Meters

Measure output signals without breaking the loop

The Fluke 771, 772 and 773 mA Process Clamp Meters pay for themselves. These meters save time by measuring 4 to 20 mA signals (five) times faster than traditional DMMs without operator intervention, offering loop calibration, voltage testing and eliminate time wasting activities.

Use the Fluke 771, 772 and 773 to:

- Measure 4-20 mA signals without “breaking the loop,” save time and money troubleshooting

Use the Fluke 772 and 773 to:

- Source 4-20 mA signals for testing control system I/O or I/Ps
- Simulate 4-20 mA signals for testing control system I/O
- Measure 4-20 mA signals with in-circuit measurement
- Power a transmitter with the 24 V loop power supply
- Automatically ramp and step change the 4-20 mA output for remote testing

Use the Fluke 773 to:

- Measure dc voltage to verify 24 V power supplies or voltage I/O signals
- Source dc voltage to test voltage input devices
- Scaled mA output signal enables a logging DMM (289) or 709H Precision Loop Calibrator to record 4-20 mA signal without breaking the loop
- mA in/out: simultaneously source a mA signal while measuring a mA signal with the clamp



Features

	mA measure w/jaw	mA measure In circuit	mA source	mA sim	Loop power 24 V	DCV source 0-10 V	DCV measure 0-30 V	Scaled mA output to mA input	mA in/out
771	•								
772	•	•	•	•	•				
773	•	•	•	•	•	•	•	•	•

Specifications

	Function	Resolution and range	Accuracy	Notes
771, 772, 773	mA measurement	0 mA to 20.99 mA 21.0 mA to 100.0 mA	0.2% + 5 counts 1% + 5 counts	Measured by clamp
772 and 773	mA measurement	0 mA to 24.00 mA	0.2% + 2 counts	Measured in series with test jacks
772 and 773	mA source	0 mA to 24.00 mA	0.2% + 2 counts	Maximum mA drive: 24 mA into 1,000 ohms
772 and 773	mA simulate	0 mA to 24.00 mA	0.2% + 2 counts	Maximum voltage 50 V dc
773	Voltage source	0 V dc to 10.00 V dc	0.2% + 2 counts	2 mA maximum drive current
773	Voltage measure	0 V dc to 30.00 V dc	0.2% + 2 counts	

General specifications

	771	772	773
Battery	Two 1.5 V, Alkaline, IEC LR6	Four 1.5 V, Alkaline, IEC LR6	
Working hours	20 hours typical	12 hours @ 12 mA source into 500 ohms	
Size (HxWxL)	59 mm x 38 mm x 212 mm (2.32 in x 1.5 in x 8.35 in)	41.3 mm x 76 mm x 248 mm (1.625 in x 3 in x 9.75 in)	
Weight	260 g (9.1 oz)	415 g (14 oz)	
Operating temperature	-10 °C to 50 °C		
IP rating	IP 40		
Warranty	Three-year, one-year on mA clamp assembly and cable		

Ordering information

Models	Included accessories
FLUKE-771 Milliamp Process Clamp Meter	Soft carrying case, users manual
FLUKE-772 Milliamp Process Clamp Meter	Test leads, alligator clips and hanging strap, soft carrying case, users manual
FLUKE-773 Milliamp Process Clamp Meter	



Measure process and other automation 4 to 20 mA signals without breaking the loop.



PROCESS CALIBRATION TOOLS

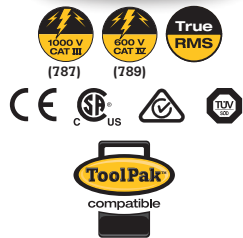

Fluke 789 and 787 ProcessMeter™ Test Tools

Combine the functionality of a loop calibrator with the power of a digital multimeter

Fluke 789 ProcessMeter

The Fluke 789 ProcessMeter is the ultimate troubleshooting tool for process technicians. Add the wireless data logging capabilities of Fluke Connect® with ShareLive™ video call, and process technicians can do a lot more while carrying a lot less.

- Unique new wireless measurement logging capability
- 24 V loop power supply
- HART mode setting with loop power (adds 250 ohm resistor)
- 20 mA drive into 1200 ohms
- 0% to 100% mA Span Check buttons to toggle between 4-20 mA
- Infrared I/O serial port compatible with FlukeView® Forms Software

Fluke 787 ProcessMeter

- Simultaneous mA and % of scale readout on mA output
- 25% Manual Step plus Auto Step and Auto Ramp on mA output
- Min/Max/Avg/Hold/Relative modes

Specifications

Measurement function	Best accuracy range and resolution	(% of reading + LSD)
V dc	400.0 mV, 4.000 V, 40.00 V, 400.0 V, 1000 V	0.1% + 1
V ac (true-rms)	400.0 mV, 4.000 V, 40.00 V, 400.0 V, 1000 V	0.7% + 2
mA dc	30.000 mA	.05% + 2
A dc	1.000 A (0.440 A continuous)	0.2% + 2
A ac	1.000 A (0.440 A continuous)	1% + 2
Resistance	400.0 Ω, 4.000 kΩ, 40.00 kΩ, 400.0 kΩ, 4.000 MΩ, 40.00 MΩ	0.2% + 1
Frequency (0.5 Hz to 20 kHz)	199.99 Hz, 1999.9 Hz, 19.999 kHz	0.005% + 1
Diode test	789: 2.000 V (shows diode voltage drop) 787: 2.400 V (shows diode voltage drop)	2% + 1
Continuity	Beeps for resistance < approx. 100 ohms	

Output function	Range and resolution	Drive capability	Accuracy (% of span)
DC current output-source mode (internal battery operation)	0.000 mA to 20.000 mA or 4.000 mA to 20.000 mA (selectable at power-up) Over-range to 24.000 mA	789: 24 V compliance or, 1,200 ohms, @ 20 mA 787: 12 V compliance or, 500 ohms, @ 20 mA	0.05%
DC current output-simulate mode (external 24 V loop supply, up to 48 V on 789 only)	0.000 mA to 20.000 mA or 4.000 mA to 20.000 mA, (selectable at power-up) Over-range to 24.000 mA	1000 ohms, @ 20 mA	0.05%
24 V loop supply	789: Minimum 24 V, 787: Not available	250 ohms @ 20 mA	> 24 V
Current adjustment modes	Manual: coarse, fine, 25% and 100% step (100% step 789 only) Automatic: slow ramp, fast ramp, 25% step		

General specifications

Temperature range	18 °C to 28 °C for one year after calibration
Maximum voltage	1000 V rms (applied between any jack and earth ground)
Temperature	-40 °C to 60 °C (storage); -20 °C to 55 °C (operating)
Relative humidity	95% up to 30 °C; 75% up to 40 °C; 45% up to 50 °C; 35% up to 55 °C
Safety	IEC 61010-1: 600 V CAT IV / 1000 V CAT III
Size (HxWxL)/weight (787 w/ holster)	52 mm x 98 mm x 201 mm (2.06 in x 3.86 in x 7.93 in)/638 g (1.4 lb)
Size (HxWxL)/weight (789)	50 mm x 100 mm x 203 mm (1.97 in x 3.94 in x 8.00 in)/600 g (1.3 lb)
Warranty	Three-year

Ordering information

Models	Included accessories
FLUKE-789 ProcessMeter	Test leads, alligator clips, 4 AA alkaline batteries (installed), quick reference guide, users manual, multi-language manual CD
FLUKE-787 ProcessMeter	Test leads, alligator clips, holster with test lead storage, one 9 V alkaline battery (installed), quick reference guide, users manual, multi-language manual CD



Fluke 789 ProcessMeter is two tools in one, a CAT IV 600V safety rated DMM and a full functioning mA loop calibrator. Perfect for instrumentation and I and E technicians.



Fluke 715, 707 and 705 Loop Calibrators

Delivers outstanding performance, durability and reliability

Fluke 715 Loop Calibrator

The Fluke 715 Volt/mA Calibrator can measure loop current as well as voltage output.

- Source voltage to 200 mV or 20 V
- Measure loop current (0-20 mA, 4-20 mA) signals with 0.01 % accuracy and 1 μ A resolution
- Measure voltage output process signals from PLCs, transmitters
- Source or simulate 4-20 mA loop current
- 24 V loop supply with simultaneous current measurement
- Ramp and Step Ramp output functions

Fluke 707 and 705 Loop Calibrators

With large displays and simple interface, the Fluke 707 and 705 provide easy to use, one-hand operation.

- Innovative output adjustment dial on 707 for 1 μ A and 100 μ A resolution
- Simultaneous mA and % readout for quick, easy interpretation of readings
- mA accuracy of 0.015 % on the Fluke 707 and 0.02 % on the 705
- HART™ mode on 707 connects 250 ohm resistor in series with 24 V loop for compatibility with HART communicators
- Push button 25 % steps for fast, easy linearity checks
- “Span Check” for fast confirmation of zero and span
- Selectable slow and fast linear step ramp provide ramping outputs for valve slewing, remote testing and loop functional tests
- 24 V internal loop supply, so you can power and read a transmitter at the same time without carrying a DMM
- 0-20 mA or 4-20 mA default start up modes

Specifications

Functions	Fluke 705 and 707	Fluke 715	
Voltage measurement			
Range	0 V to 28 V	0 mV to 200 mV	0 V to 25 V
Resolution	1 mV	10 μ V	1 mV
Accuracy	705: 0.025 % Rdg + 1 LSD 707, 707Ex: 0.015 % Rdg + 2 LSD	0.01 % Rdg + 2 LSD	
Current measurement			
Range	0 mA to 24 mA	0 mA to 24 mA	
Resolution	0.001 mA	0.001 mA	
Accuracy	705: 0.02 % Rdg + 2 LSD 707, 707Ex: 0.015 % Rdg + 2 LSD	0.01 % + 2 LSD	
Current sourcing			
Range	0 mA to 20 mA or 4 mA to 20 mA	0 mA to 20 mA or 4 mA to 20 mA	
Accuracy	705: 0.025 % Rdg + 2 LSD 707, 707Ex: 0.015 % Rdg + 2 LSD	0.01 % Rdg + 2 LSD	
Drive capability	705: 1000 W @ 24 mA 707: 1200 W @ 24 mA 707Ex: 700 W @ 20 mA	1000 W @ 24 mA	
Loop power while measuring mA	24 V	24 V	
Voltage sourcing			
		0 mV to 200 mV or 0 V to 20 V	
Display current and % of span	•	mA or %	
Auto step, auto ramp	•	•	
Span Check	•	•	
Battery life	18 hours typical at 12 mA	18 hours typical at 12 mA	
Warranty	Three-year		

Ordering information

Models	Included accessories
FLUKE-715 Volt/mA Calibrator	
FLUKE-707 Loop Calibrator	Test leads, alligator clips, holster, traceable calibration report and data, single 9 V alkaline battery, instruction sheet (14 languages)
FLUKE-705 Loop Calibrator	



Fluke loop calibrators are reliable and accurate. The 709H adds basic HART communication (see page 58).



PROCESS CALIBRATION TOOLS



Calibrate and document the performance of HART smart pressure transmitters with the Fluke 754 and 750 Series Pressure Modules.



Fluke 753 and 754 Calibrators

Does the work of several tools for process systems

- Calibrate temperature, pressure, voltage, current, resistance and frequency instruments
- Built-in procedures for transmitters, square root transmitters, pressure and temperature switches
- Simultaneously measure and source
- Automatically capture calibration results
- Document procedures and results to meet ISO 9000, EPA, FDA, OSHA and other requirements
- Measure/simulate 13 types of thermocouples and eight RTDs

754: Get HART-ability™

The Fluke 754 offers all of the capabilities of the 753, plus the ability to calibrate, maintain and troubleshoot HART instrumentation. Integrated HART communication functions permit you to monitor, control and calibrate HART instrumentation. It handles fast pulsed instruments such as RTD transmitters and PLCs responding to pulses within 1 ms.

753: A complete documenting calibrator

The 753 is a complete multifunction documenting calibrator and includes a PC interface that lets you load procedures, lists and instructions created with software—or unload data for printing, archiving, and analysis. The 753 can hold a full week of calibrations and procedures.

Fluke 709/709H Precision Current Loop Calibrators

- Best-in-class accuracy at 0.01 % reading
- HART Communication (709H only) communicate with and test HART smart instruments
- 24 V dc loop power with mA measure mode
- Built in selectable 250 Ω resistor for HART communications
- Valve test (source and simulate defined mA values with % keys)
- Upload logged mA measurements and HART device data using the 709H with optional 709H/TRACK software

75X Calibrator Specifications

	Measure	Sourcing
DC voltage	0.020 % reading + 0.005 % full scale	0.01 % output + 0.005 % full scale
DC current	0.01 % reading + 5 μA	0.01 % output + 0.003 mA
Resistance	0.05 % reading + 50 mΩ	0.01 % output + 240 mΩ
Frequency	0 to 50 KHz, ± 0.5 Hz to 1100 Hz	0 to 50 KHz, ± 0.1 Hz to 1099.9 Hz
Thermocouples	0.3 °C	0.2 °C
RTDs	0.3 °C	0.1 °C
Pressure	To 0.025 % of full scale, per pressure module specifications (Fluke 750P Series)	
Battery life	Typically over eight hours	
Internal battery pack	Li ion 4400 mAh	
Size (HxWxD)	245 mm x 136 mm x 63 mm (9.6 in x 5.4 in x 2.5 in)	
Weight	1.2 kg (2.7 lb)	
Calibration cycles	One- and two-year	
Warranty	Three-year	

Ordering information

Models	Included accessories
FLUKE-754 Documenting Process Calibrator-HART	Three sets of stackable test leads, three sets of test probes with three sets of “extended tooth” alligator clips, two sets of hook clips, li-ion battery pack, battery charger, field soft case, USB communication cable, getting started guide, instruction manual on CD, traceable certificate of calibration, DPC/TRACK2 sample software that enables upload and printing of calibration records. HART communication cable (754 only)
FLUKE-753 Documenting Process Calibrator	
FLUKE-709 Precision Current Loop Calibrator	Test leads, test probes and alligator clips. Quick reference guide, traceable certificate of calibration, manual on CD. Additional hook clips (709H only) for HART communication
FLUKE-709H Precision Current Loop Calibrator-HART	

HART is a registered trade mark of the HART Communications Foundation.

Fluke 726 and 725 Multifunction Process Calibrators

Calibrate almost anything

The Fluke 726 and 725 measure and source nearly all process parameters. Interpret results without the help of a calculator and store measurement data for later analysis.

- Precise measurement and calibration source performance, accuracies of 0.01 % (726)
- Transmitter error % calculation, source/simulate volts, mA, thermocouples, RTDs, frequency, ohms and pressure to calibrate transmitters
- Memory storage for up to eight calibration setups
- Frequency totalizer and pulse train source mode for enhanced flowmeter testing (726)
- HART mode inserts 250 ohm resistor in mA measure and source mode
- Integrated pressure switch test to capture the set, reset and deadband of a switch (726)
- RTD curves, add temperature calibration constants for certified RTD probes
- Voltage input protection design for improved reliability
- Measure/source pressure using any of 50 Fluke 750Pxx Pressure Modules
- Source mA with simultaneous pressure measurement to conduct valve and I/P tests
- Perform fast linearity tests with auto step and auto ramp features
- Intrinsically safe version available (725)



(725)

Measure and source

Functions	Range or type	Resolution	Accuracy	Notes
Voltage dc	0 to 100 mV 0 to 10 V (source) 0 to 20 V (source) 0 to 30 V (measure)	0.001 mV 0.001 V 0.001 V 0.001 V	0.01 % , 0.02 % Rdg + 2 LSD	Max load, 1 mA
mA	0 to 24	0.001 mA	0.01 % , 0.02 % Rdg + 2 LSD	Max load, 1000 Ω
mV (TC terminals)	-10.00 mV to +75.00 mV	.01 mV	0.01 % , 0.02 % of range + 1 LSD	
Ohms	15 Ω to 3,200 Ω 5 Ω to 4,000 Ω	0.01 Ω to 0.1 Ω	0.10 Ω to 1.0 Ω 0.015 %	
Hz - CPM	2.0 to 1,000 CPM 1 to 1000 Hz 1.0 to 10.0 kHz 10.0 to 15.0 kHz	0.1 CPM 1 Hz 0.1 kHz 0.1 kHz	± 0.05 % ± 0.05 % ± 0.25 % ± 0.05 %	Source; 5 V p-p 1 V to 20 V p-p squarewave, -0.1 V offset
Loop supply	24 V dc	N/A	10 %	
T/C	J, K, T, E, L, N, U, XK	0.1 °C, 0.1 °F	to 0.7 °C to 0.2 °C	
T/C	B, R, S, BP	1 °C, 1 °F	to 1.7 °C to 1.2 °C	
RTDs	Cu (10) , Ni120 (672) Pt 100, 200, 500, 1000 (385) Pt 100 (3916), Pt 100 (3926)	0.01 °C , 0.01 °F 0.1 °C, 0.1 °F	to 0.15 °C to 0.2 °C	

General specifications

Storage/operating temperature	-20 °C to 71 °C/-10 °C to 55 °C (726: -10 °C to 50 °C)
Relative humidity	90 % (10 °C to 30 °C); 75 % (30 °C to 40 °C); 45 % (40 °C to 50 °C); 35 % (50 °C to 55 °C)
Shock	1 meter drop test
Battery life	25 hours typical (4 AA alkaline batteries)
Size (HxWxD)	200 mm x 96 mm x 47 mm (7.9 in x 3.8 in x 1.9 in)
Weight	650 g (23 oz)
Warranty	Three-year

Unique 726 specifications are bold.

Ordering information

Models	Included accessories
FLUKE-726 Precision Multifunction Process Calibrator	Test leads, test clips, one pair of stackable test leads, traceable certificate of calibration, product overview manual, users manual in 14 languages on CD
FLUKE-725 Multifunction Process Calibrator	



Calibrate temperature transmitters easily with Fluke 725 and 726 calibrators.

Add a 750P series pressure module to the 725 or 725 to make it a pressure calibrator.





Fluke 712B, 714B and 724 Temperature Calibrators

Highly accurate single function temperature calibrator

For the temperature calibration professional that wants a highly accurate, easy-to-use, single function temperature calibrator the 712B and 714B are ideal. For temperature calibration professionals, these temperature calibrators deliver outstanding performance, durability and reliability and each calibrator is EMI tolerant, dust- and splash-resistant, and features a removable battery door for quick battery changes.

- The 712B can measure and simulate (13) different RTD types and resistance
- The 714B can measure and simulate (17) different thermocouple types and millivolts
- Measure 4 to 20 mA signals while simultaneously sourcing a temperature signal
- The 724 specialty model will source/measure TCs, RTDs, volts and ohms as well as measure mA while supplying loop power
- Hanging tool designed in and included with every unit (712B and 714B)
- Configurable 0% and 100% source settings for quick 25% linearity checks
- Linear ramp and 25% step auto ramp based on 0% and 100% settings
- Dual inputs and backlit display for easy interpretation of measurements
- Power down settings remembered at power up for easy restart of tests
- One-year and two-year specifications and traceable certificate of calibration (712B and 714B)

Specifications

	Functions	Range	Resolution	Accuracy	Notes
712B	Measure/Simulate RTD	-200 °C to 800 °C (Pt 100-385)	0.1 °C, 0.1 °F	0.2 °C, 0.4 °F (Pt 100-385)	13 types Pt; 100 200 500 1000 (385); Pt 100 (392); Pt 100 (392) JIS; Ni 120 (672)
	Measure/Simulate Resistance	0.00 Ω to 400.00 Ω 400.0 Ω to 4000.0 Ω	0.01 Ω 0.1 Ω	0.015% + 0.005 Ω 0.015% + 0.05 Ω	
714B	Measure/Simulate Thermocouple	-200 °C to 1800 °C, depending on type (K, -200 °C to 1370 °C)	0.1 °C or °F (1 °C or °F; BRS)	0.5 °C, 0.8 °F (Type K)	17 TC types; J K T E R S B per NIST 175 and ITS-90 L U per DIN 43710 and PTS-68
	Measure/Simulate mV	10 mV to 75 mV	0.01 mV	0.015% + 10 μV	

General specifications (712B/714B)

Maximum voltage	30 V
Operating temperature	-10 °C to 50 °C
Power	4 AA alkaline batteries/NEDA code: 15A, IEC code: LR6
Safety/EMC	IEC 61010-1, Max 30 V to earth, Pollution Degree 2/IEC 61326-1, Portable
Size (HxWxD)	188.5 mm x 84 mm x 52 mm (7.42 in x 3.31 in x 2.04 in)
Weight	515 g (18.16 oz)
Warranty	Three-year

714B is the ideal tool for testing thermocouple input temperature transmitters.



Ordering information

Models	Included accessories
FLUKE-724 Temperature Calibrator	Test leads, test clips, one pair of stackable test leads, product overview manual, users manual in 14 languages on CD
FLUKE-714B Thermocouple Calibrator	Test leads, alligator clips (excluding model 714), holster with test lead storage, single 9 V alkaline battery and instruction sheet (14 languages)
FLUKE-712B RTD Calibrator	

Fluke Pressure Calibrators

Fluke 719 and 719PRO Electric Pressure Calibrators

- Electric pump enables one-handed pressure pumping
- Best in class 0.025 % pressure measurement accuracy
- Programmable pump limit settings can eliminate over-pressurization
- Precision vernier for fine pressure adjustment
- Variable release rate bleed valve for controlled pressure release
- Pressure switch test makes a difficult task easy, captures set, reset and deadband values of a pressure switch
- Measure mA with 0.015 % accuracy, while sourcing 24 V loop power
- 719: Two ranges, 2 bar and 7 bar
- 719PRO: Three ranges 2 bar, 10 bar and 20 bar
- 719PRO: Precision temperature measurement with optional 720RTD Probe



Fluke 718 Pressure Calibrators

- 70 mbar, 2 bar, 7 bar and 20 bar ranges available
- Pump to 20 bar (300 psi) with internal hand pump (718-300G)
- 718-1G includes special low volume pump and high measurement resolution for low pressure calibration
- Precision vernier for fine pressure adjustment
- Variable release rate bleed valve for controlled pressure release
- Pressure switch test makes a difficult task easy, captures set, reset and deadband values of a pressure switch
- Measure pressure to 0.025 % of full scale
- Measure mA with 0.015 % accuracy, while sourcing 24 V loop power

Fluke 717 Pressure Calibrators

- Measure up to 690 bar (10.000 psi) sensor (10000G model)
- Compatible with non-corrosive gases and liquids on 500 psi and higher ranges
- Pressure switch test makes a difficult task easy, captures set, reset and deadband values of a pressure switch
- Measure pressure to 0.025 % of full scale
- Measure mA with 0.015 % accuracy, while sourcing 24 V loop power



Fluke 750P Series Pressure Modules

50 pressure modules covers pressure calibrations from 0 to 1 in H₂O to 10000 psi 2.5 mBar to 690 bar.

- 0.025 % reference uncertainty
- 6-month and 1-year specifications
- Temperature compensated 0 °C to 50 °C
- Digital communication to calibrators, no analog losses or errors
- Gage, differential, dual range, absolute and vacuum measurement models

Ordering information

Models		Included accessories
FLUKE-719PRO 30G Electric Pressure Calibrator	FLUKE-717 15G Pressure Calibrator	Test leads, alligator clips, holster, test hose (719), one 9 V alkaline battery (two 9 V batteries in 718 and 719), 8 AA batteries in the 719PRO and safety sheet.
FLUKE-719PRO 150G Electric Pressure Calibrator	FLUKE-717 30G Pressure Calibrator	
FLUKE-719PRO 300G Electric Pressure Calibrator	FLUKE-717 100G Pressure Calibrator	
FLUKE-719 30G Electric Pressure Calibrator	FLUKE-717 300G Pressure Calibrator	
FLUKE-719-100G Electric Pressure Calibrator	FLUKE-717 500G Pressure Calibrator	
FLUKE-718 1G Pressure Calibrator	FLUKE-717 1000G Pressure Calibrator	
FLUKE-718 30US Pressure Calibrator	FLUKE-717 1500G Pressure Calibrator	
FLUKE-718 100US Pressure Calibrator	FLUKE-717 3000G Pressure Calibrator	
FLUKE-718 300G Pressure Calibrator	FLUKE-717 5000G Pressure Calibrator	
FLUKE-717 1G Pressure Calibrator	FLUKE-717 10000G Pressure Calibrator	



Fluke 721 Precision Pressure Calibrator

Features dual-range isolated pressure sensors

- Ideal tool for gas custody transfer applications
- Take simultaneous static and differential pressure measurements with a single tool
- Best in class accuracy of 0.025 %, for gas measurement applications
- Pt100 RTD input for precision temperature measurement (probe optional)
- Measures 4 to 20 mA signals and provides 24 V loop power
- Measure up to 30 V dc to check 24 V loop power supplies
- Extend pressure measurement range with connection to external 750P Series Pressure Modules (50 ranges)
- I.S. rated models available. IS models do not have 24 V loop power, measure voltage or have connectivity to pressure modules

Specifications

Model	Low pressure sensor			High pressure sensor		
	Range sensor 1	Resolution sensor 1	Accuracy sensor 1	Range Sensor 2	Resolution sensor 2	Accuracy sensor 2
Fluke-721-1601	-970 mbar to +1.1 bar	0.0001 bar	0.025 % of full scale	-0.83 bar to 6.9 bar	0.0001 bar	0.025 % of full scale
Fluke-721-1603				-0.83 bar to 20 bar	0.001 bar	
Fluke-721-1605				-0.83 bar to 34.5 bar	0.001 bar	
Fluke-721-1610				0.00 bar to 69 bar	0.001 bar	
Fluke-721-1615				0.00 bar to 103.4 bar	0.001 bar	
Fluke-721-1630				0.00 bar to 200 bar	0.01 bar	
Fluke-721-1650				0.00 bar to 345 bar	0.01 bar	
Fluke-721-3601	-970 mbar to 2.48 bar	0.0001 bar	0.025 % of full scale	-0.83 bar to 6.9 bar	0.0001 bar	0.025 % of full scale
Fluke-721-3603				-0.83 bar to 20 bar	0.0001 bar	
Fluke-721-3605				-0.83 bar to 34.5 bar	0.001 bar	
Fluke-721-3610				0.00 bar to 69 bar	0.001 bar	
Fluke-721-3615				0.00 bar to 103.4 bar	0.001 bar	
Fluke-721-3630				-0.97 bar to 2.48 bar	0.01 bar	
Fluke-721-3650				0.00 bar to 345 bar	0.01 bar	



Fluke 700G Series Precision Pressure Test Gauges

Twenty three ranges to choose from

- Seven Reference Class gauge ranges with $\pm .04\%$ of reading accuracy: 2 bar, 7 bar, 34 bar, 69 bar, 200 bar, 340 bar, 690 bar
- Two Low pressure measurement ranges with $\pm .1$ of reading accuracy: 25 mbar (10 inH2O), 68.5 mbar (1 psi)
- Fourteen precision test gauge ranges with $\pm .05\%$ of reading accuracy: 1 bar, 2 bar, 7 bar, 20 bar, 34 bar, 69 bar, 140 bar, 200 bar, 340 bar, 690 bar
- Four Absolute pressure measurement ranges: 1, 2, 7 and 20 bar absolute
- CSA; Class 1, Div 2, Groups A-D rating
- ATEX rating: II 3 G Ex nA IIB T6
- Combine with the 700TPK or 700HTPK pump kits for a complete pressure testing solution for up to 600 psi (40 bar) with the 700TP-1 pneumatic pump and up to 10,000 psi (690 bar) with the 700HTP-2 hydraulic pump
- Log up to 8,493 pressure measurements to memory (requires 700G/TRACK software)
- Three-year warranty

Ordering information

Models	Included accessories
FLUKE-721 Precision Pressure Calibrator (all models)	Soft case, Four (4) AA batteries, manual, traceable calibration certificate, test leads
FLUKE-700G/700RG Precision Pressure Test Gauges (all models)	Manual on CD-ROM in 14 languages, traceable certificate of calibration, 1/4 in NPT to 1/4 in ISO adapter

Fluke products designed to intrinsic safety standards

A protection method employed in potentially explosive atmospheres, intrinsically safe devices are designed to be unable to release sufficient energy, by either thermal or electrical means, to cause ignition of flammable material (gas or dust/particulates).

Fluke products	ATEX certified	North American Certification
 28 II Ex: Intrinsically Safe True-rms Multimeter	 II 2G Ex ia IIC T4 Gb II 2D Ex ia IIC T130 °C Db I M1 Ex ia I Ma	 Class I Zone 1 AEx ia IIC T4 Class II Zone 21 AEx iaD T130C USA and Canada Class 1 Div 1 Groups ABCD Class 1 Div 2 Groups ABCD Class 2 Div 1 Groups EFG Class III Ex ia IIC
 707Ex: Intrinsically Safe mA Calibrator	 II 2 G Ex ia IIC T4	 C 221830 Class I, Div 2, Groups A-D
 718Ex: Intrinsically Safe Pressure Calibrator	 II 1 G Ex ia IIC T4	 C LR 110480 I.S. Class I, Div 1, Groups A-D T4
 721Ex: Intrinsically Safe Precision Pressure Calibrator	 ATEX: II 2G Ex ia IIB T3 Gb	 C 221830 IECEX II 2 G
 725Ex: Intrinsically Safe Multifunction Calibrator	 II 1 G Ex ia IIB 171 °C	 C LR 110480 I.S. Class I, Div 1, Groups B-D, 171 °C
 700PEx: Intrinsically Safe Pressure Modules	 II 1 G Ex ia IIC T4	 C 221830 I.S. Class I, Div 1, Groups A-D T4
 568Ex: Intrinsically Safe Infrared Thermometer	 ATEX/IECEX Zone 1 and 2	 NEC-500/NEC-505 Class I Division 1 and 2
 700G Series Intrinsically Safe Pressure Gauges	 II 3 G Ex ia IIB T6	 C LR 110480 CSA Class I, Div. 2 Groups A-D rating
 1551A/1552A: Intrinsically Safe "Stik" Thermometer	 ATEX/IECEX Zone 1 and 2	 NEC-500/NEC-505 Class I Division 1 and 2

Ordering information

Models
FLUKE-28 II Ex IS True-rms Multimeter
FLUKE-568 Ex Intrinsically Safe Infrared Thermometer
FLUKE-700G Pressure test Gauge, 23 pressure ranges from 0 to 10 inH2O up to 10,000 psi
FLUKE-700PEX Pressure Modules (700P: 01, 05, 06, 09, 24, 27, 29, A4Ex)
FLUKE-707Ex IS Loop Calibrator
FLUKE-718Ex IS Pressure Calibrator
FLUKE-721Ex Precision Pressure Calibrator
FLUKE-725Ex IS Multifunction Process Calibrator
1551A Ex "Stik" Thermometer -50 °C to 160 °C (-58 °F to 320 °F)
1552A Ex "Stik" Thermometer -80 °C to 300 °C (-112 °F to 572 °F)

There are no global intrinsically safe standards or certifications, but there are organizations that influence directives in certain world geographies.



APPROVED

Factory Mutual

In the United States, Factory Mutual Research, managed by Factory Mutual (FM) Global, is a non-profit scientific and testing organization that has tested and certified over 40,000 products in the last 165 years. FM Research has set certification guidelines for equipment used in potentially explosive atmospheres.



Canadian Standards Association (CSA)

Accreditation body for North American regulations, based in Toronto, Canada.



ATEX

The primary intrinsically safe standard, which has been set in the European Union with the Directive 2014/34/EU (replacing the 94/9/EC), and commonly called ATEX 114 (Atmosphères Explosibles), French for explosive atmospheres.

ETL

Accreditation body for North American regulations, NEC-500/NEC-505.

ScopeMeter® Test Tool selection guide

Handheld oscilloscopes for industrial, instrumentation and electronic applications

These handheld battery-powered oscilloscopes are easy to use, with a built-in multimeter, paperless recording and analysis capabilities. They are rugged and IP51 dust and drip-proof rated to IEC529 standards to withstand harsh environments.

	120B Series			190 Series II						
	123B	124B	125B	190-062	190-102	190-202	190-104	190-204	190-502	190-504
Bandwidth										
20 MHz	•									
40 MHz		•	•							
60 MHz				•						
100 MHz					•		•			
200 MHz						•		•		
500 MHz									•	•
Input channels										
2Ch + 2 DMM	•	•	•							
2Ch + DMM				•	•	•			•	
4Ch							•	•		•
Isolated inputs				•	•	•	•	•	•	•
Triggering										
Connect-and-View™	•	•	•	•	•	•	•	•	•	•
IntellaSet Technology	•	•	•							
Advanced triggering				•	•	•	•	•	•	•
Advanced measurement function										
Cursors		•	•	•	•	•	•	•	•	•
TrendPlot	•	•	•	•	•	•	•	•	•	•
ScopeRecord™	•	•	•	•	•	•	•	•	•	•
100 screen replay				•	•	•	•	•	•	•
Industrial BusHealth			•							
Harmonics			•							
FFT				•	•	•	•	•	•	•
Power measurements			•	•	•	•	•	•	•	•
Waveform mathematics			•	•	•	•	•	•	•	•
EN61010-1 safety										
CAT II 1000 V				•	•	•	•	•	•	•
CAT III 600 V				•	•	•	•	•	•	•
CAT III 1000 V				•	•	•	•	•	•	•
CAT IV 600 V	•	•	•	•	•	•	•	•	•	•
Interface										
Optical RS-232	•	•	•							
USB PC interface	Opt	Opt	Opt	•	•	•	•	•	•	•
Optional WiFi adapter	•	•	•							
USB memory port				•	•	•	•	•	•	•
Power										
Li-Ion	•	•	•	•	•	•	•	•	•	•
Battery (hours)	7	7	7	4 (opt 8)	4 (opt 8)	4 (opt 8)	7	7	7	7
General specifications										
Size (HxWxD)	259 mm x 132 mm x 55 mm (10.2 in x 5.2 in x 2.15 in)			270 mm x 190 mm x 70 mm (10.5 in x 7.5 in x 2.8 in)						
Weight	1.4 kg (3.2 lb)			2.2 kg (4.8 lb)						
Fluke Connect®										
Fluke Connect® app	•									

Fluke 120B Series Industrial ScopeMeter® Test Tools

Three-in-one simplicity

The compact ScopeMeter® 120B Series, is the rugged oscilloscope solution for industrial electrical and electro-mechanical equipment troubleshooting and maintenance applications. It's a truly integrated test tool, with oscilloscope, multimeter and high-speed recorder in one easy-to-use instrument. The ScopeMeter 120B Series also integrates with Fluke Connect® mobile app and FlukeView® for ScopeMeter software to enable further collaboration, data analysis and archiving of critical test information.

- Dual-input digital oscilloscope and multimeter
- 40 MHz or 20 MHz oscilloscope bandwidth
- Two 5,000-count true-rms digital multimeters
- Dual-input waveform and meter reading recorder for trending data over extended periods
- Recorder Event Detect captures elusive intermittent signals on repetitive waveforms up to 4 kHz

Connect-and-View™ triggering for an instant, stable display

Fluke's unique Connect-and-View recognizes signal patterns and automatically and continuously sets up correct triggering. It provides a stable, reliable and repeatable display of virtually any signal.

IntellaSet™/AutoReading technology displays critical measurement data

The Auto Readings function with Fluke IntellaSet™ technology uses proprietary algorithms to intelligently analyze the measured waveform and automatically displays the most appropriate numerical measurements on screen, so you can get the data you need easier than ever before. As an example, when the measured waveform is a line voltage signal, the Vrms and Hz readings are automatically displayed, whereas if the measured waveform is a square wave, the Vpeak-peak and Hz readings are automatically displayed.

Fluke Connect mobile app compatibility

The Fluke Connect® Assets wireless system of software and wireless test tools enables technicians to reduce maintenance costs and increase uptime with accurate equipment records and maintenance data that is easy to interpret, and share. Compare and contrast test point measurement data and trends so you can better understand signal characteristics and changes over time.

Ordering information

Models	Included accessories
FLUKE-125/B Industrial ScopeMeter® Hand Held Oscilloscope (40 MHz)	Li-Ion battery pack, charger/power adapter, 2 shielded test leads with ground leads, black test lead, red and blue hook clips, banana to BNC adapter, and WiFi USB adapter**
FLUKE-124/B Industrial ScopeMeter® Hand Held Oscilloscope (40 MHz)	
FLUKE-123/B Industrial ScopeMeter® Hand Held Oscilloscope (20 MHz)	

**WiFi USB adapter NOT available in all countries. Check with your local Fluke representative.

Kits—buy more, save more

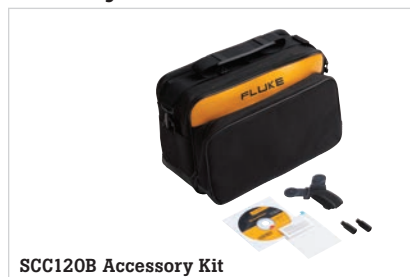

Recommended accessories



Fluke Connect-and-View™ triggering with Auto Reading function using Fluke IntellaSet™ technology gives you quick access to the data you need.

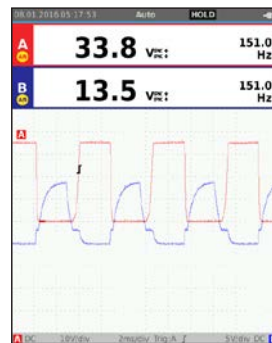

Dual input oscilloscope, meter and paperless recorder.





Fluke 190 Series II ScopeMeter® Test Tools

Faster sample rates. More detail. Greater accuracy.

Safety rated for industrial applications, the 190 Series ScopeMeter portable oscilloscopes are the first high-performance four-channel scopes built for harsh industrial environments and can go where ordinary scopes can't. They combine rugged portability with high performance to take you all the way from troubleshooting microelectronics to power electronic applications.

For the first time, plant maintenance engineers and technicians can take a high-performance four-channel scope into the harsh world of industrial electronics. The new Fluke 190 Series II is the only portable oscilloscope with two or four independent isolated input channels, a CAT III 1000 V/CAT IV 600 V safety rating, and sealed case IP51 dust-proof and drip-proof rated.

- 60 MHz, 100 MHz, 200 MHz or 500 MHz bandwidth
- 2 or 4 independent isolated inputs, up to 1000 V
- High-speed sampling: Up to 5 GS/sec
- Deep memory: 10,000 points per trace waveform capture (scope mode)
- CAT III 1000 V/CAT IV 600 V safety rated for high voltage environments
- 5,000 count multimeter 2 channel models or 999 count volt meter 4 channel models
- Li-ion battery and easy-access battery door for extended usage

Automatic capture and replay of 100 screens

ScopeMeter Portable Oscilloscope users know how frustrating it is to see a one-time anomaly flash by—never to be seen again. With the ScopeMeter 190 Series II, you can look back in time with a touch of the replay button. The instrument continuously memorizes the last 100 screens, on a first in-first out basis. At any moment you can “freeze” the last 100 screens and scroll through picture-by-picture or replay as a “live” animation.

ScopeRecord™ mode for high-resolution waveform recording up to 48 hours

ScopeRecord memory stores up to 30,000 data points per channel, capturing fast intermittents and glitches as short as 8ns. Stores events like motion profiles, UPS, power supply and motor start-ups

The Envelope Trigger mode automatically recognizes a power failure and store the waveform data. With the waveform zoom (up to 100x) you can look at the smallest details.

TrendPlot™ Paperless Recorder

Find intermittent faults. Any number of factors like bad connections, dust, dirt, corrosion or broken wiring or connectors, line outages, sags, or starting and stopping of a motor can cause a machine to stop intermittently. You may not be around when it happens. Plot the minimum and maximum peak values and average over time—up to 22 days. Plot any combination of voltages, amps, temperature, frequency and phase for all four inputs, all with time and date stamp to pinpoint faults.

Ordering information

Models	Included accessories
FLUKE-190-502 Color ScopeMeter, 500 MHz, 2 channels plus DMM/Ext. input	Battery charger/mains adapter, Li-Ion battery pack, voltage probe sets, test leads, handstrap affixed to instrument, hangstrap (user selectable for left- or righthand use), multi-language users manuals on CD, FlukeView® demo package (with restricted functionality), USB interface cable for PC connectivity
FLUKE-190-504 Color ScopeMeter, 500 MHz, 4 channels	
FLUKE-190-204 Color ScopeMeter, 200 MHz, 4 channels	
FLUKE-190-104 Color ScopeMeter, 100 MHz, 4 channels	
FLUKE-190-202 Color ScopeMeter, 200 MHz, 2 channels plus DMM/Ext.input	
FLUKE-190-102 Color ScopeMeter, 100 MHz, 2 channels plus DMM/Ext.input	
FLUKE-190-062 Color ScopeMeter, 60 MHz, 2 channels plus DMM/Ext.input	

Kits—buy more, save more



SCC290 Kit

Recommended accessories

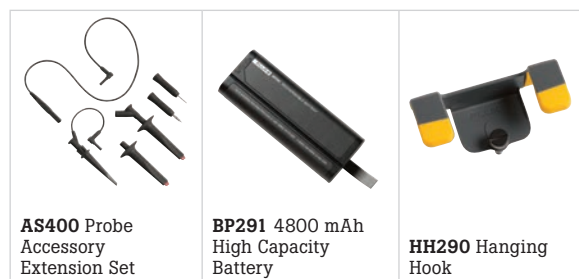

AS400 Probe Accessory Extension Set

BP291 4800 mAh High Capacity Battery

HH290 Hanging Hook

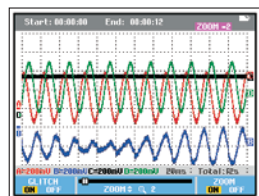

Use the 27,000 points memory of ScopeRecord and zoom in for maximum detail.

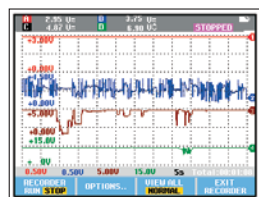

Cursors and zoom features of the Fluke 190 Series II help you to analyze the captured TrendPlot.



Fluke 190-504 ScopeMeter® Test Tool

The worlds fastest handheld oscilloscope

Now with 500 MHz bandwidth, four channels and 5 GS/s sampling speed. The powerful Fluke 190-504 Scopemeter extends your troubleshooting arsenal, showing you waveform shape, timing, distortion and disturbance in greater detail than ever before.

- Four independent isolated inputs, up to 1000 V
- Deep memory: 10,000 points per trace waveform capture
- CAT III 1000 V/CAT IV 600 V safety rated for high voltage environments
- 999 count multimeter
- Li-Ion battery and easy-access battery door for extended usage
- Isolated USB host port for direct data storage to a USB memory
- USB-B-device port for PC connectivity

The 190-504 ScopeMeter will capture and display unknown waveform shapes, amplitudes and any disturbances. To display at least the fifth harmonic component of a signal, select a scope with a bandwidth of at least five times the maximum clock rate of the device under test. The faster the sample interval, the more accurate and detailed the information the scope will display a signal edge (dV/dt) and peaks of any reflections or transients.

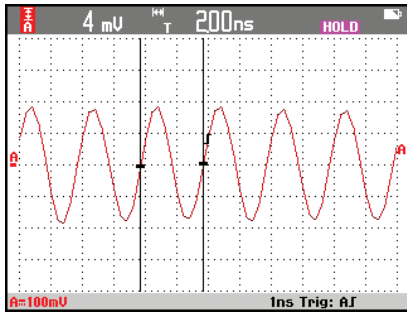

Accurately capture noise, distortion and other signal characteristics with 500 MHz bandwidth and 5 GS/sec sampling rate.

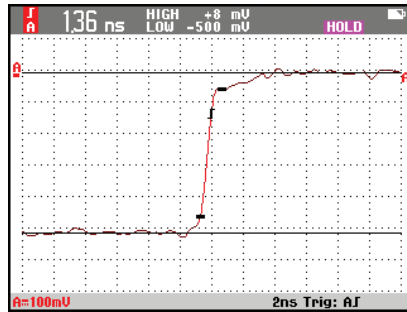

Rise time response accurately captures signals with fast edges with signs of reflections.

Ordering information

Models	Included accessories
FLUKE-190-504 Color ScopeMeter, 500 MHz, 4 channels	Battery charger/mains adapter, li-ion battery pack, voltage probe sets, 50 Ohm terminator, test leads, and strap affixed to instrument, hangstrap (user selectable for left- or righthand use), multilanguage users manuals on CD, FlukeView® demo package (with restricted functionality), USB interface cable for PC connectivity

Kits—buy more, save more

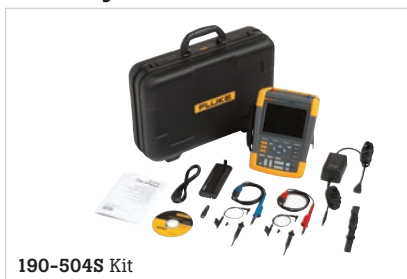

Recommended accessories



Infrared camera and visual IR thermometer selection guide

	Expert Series IR Cameras			Professional Series IR Cameras		
	TiX560	TiX520	TiX500	Ti450	Ti400	Ti300
Detector resolution	320 x 240 Super Resolution mode: 640 x 480			320 x 240	240 x 180	
Field of view	24 °H x 17 °V					
Optional lenses	Capture spectacular images close up or from a distance with pre-calibrated smart lenses: wide angle, 2x and 4x telephoto, 25 micron macro			2x and 4x telephoto and wide angle pre-calibrated smart lenses		
Wireless connectivity ¹	Fluke Connect® app compatible. Wireless connectivity to PC, iPhone® and iPad® (iOS 4s and later), Android™ 4.3 and up, and WiFi to LAN ¹					
Focus system	MultiSharp™ Focus, LaserSharp® Auto Focus with built-in laser distance meter and advanced manual focus				-	
IR-Fusion® technology/ visible context	IR-Fusion® AutoBlend™ mode and Picture-in-Picture, continuous blending		IR-Fusion® AutoBlend™ mode and Picture-in-Picture			
Display	5.7 inch touchscreen LCD, 640 x 480 pixel resolution			3.5 inch touchscreen LCD, 640 x 480 pixel resolution		
Design	Ergonomic FlexCam design with a 240 degree rotating lens			Rugged, ergonomic design for one-handed use		
Thermal sensitivity	≤ 0.045 °C at 30 °C target temp (45 mK); Filter mode ≤ 0.03 °C (30 mK)	≤ 0.05 °C at 30 °C target temp (50 mK); Filter mode ≤ 0.04 °C (40 mK)	≤ 0.05 °C at 30 °C target temp (50 mK)	≤ 0.05 °C at 30 °C target temp (50 mK); Filter mode ≤ 0.03 °C (30 mK)	≤ 0.05 °C at 30 °C target temp (50 mK)	
Temperature measurement range	-20 °C to +1200 °C (-4 °F to +2192 °F)	-20 °C to +850 °C (-4 °F to +1562 °F)	-20 °C to +650 °C (-4 °F to +1202 °F)	-20 °C to +1200 °C (-4 °F to +2192 °F)		-20 °C to +650 °C (-4 °F to +1202 °F)
Frame rate	60 Hz or 9 Hz					
Software	SmartView® software and Fluke Connect® ¹					
Documentation features	IR-PhotoNotes™, voice annotation, and text annotation					
Video recording	Standard and radiometric					
Streaming video (remote display)	Via USB or WiFi hot spot to PC or via HDMI to HDMI compatible screen					
Remote control	Yes, through SmartView® software or Fluke Connect® mobile app	-		Yes, through SmartView® software or Fluke Connect® mobile app		-
Alarms	High temperature, low temperature, time lapse - auto image capture, and isotherms (within range)					

¹Within your provider's wireless service area; Fluke Connect is not available in all countries.

	Performance Series IR Cameras						Visual IR Thermometers
	TiS75	TiS65/TiS60	TiS55/TiS50	TiS45/TiS40	TiS20	TiS10	VT04/VT04A
Detector resolution	320 x 240	260 x 195	220 x 165	160 x 120	120 x 90	80 x 60	31 x 31
Field of view	35.7 °H x 26.8 °V						28 °H x 28 °V
Optional lenses	-						
Wireless connectivity¹	Fluke Connect® app compatible. Wireless connectivity to PC, iPhone® and iPad® (iOS 4s and later), Android™ 4.3 and up, and WiFi to LAN						
Focus system	Manual focus	TiS65 (Manual focus) TiS60 (Fixed focus)	TiS55 (Manual focus) TiS50 (Fixed focus)	TiS45 (Manual focus) TiS40 (Fixed focus)	Fixed focus		
IR-Fusion® technology/ visible context	5 presets (0 %, 25 %, 50 %, 75 %, 100 %)				3 presets (0 %, 50 %, 100 %)	-	Infrared heat map and visual image blending in 25 % increments; center box to outline the temperature measurement area
Display	3.5 inch (landscape) 320 x 240 LCD						2.2 inch portrait standard TFT LCD
Design	Rugged, lightweight, ergonomic design for one-handed use						Slim, pocket-sized design
Thermal sensitivity	≤ 0.08 °C at 30 °C target temp (80 mK)			≤ 0.09 °C at 30 °C target temp (90 mK)	≤ 0.10 °C at 30 °C target temp (100 mK)	≤ 0.15 °C at 30 °C target temp (150 mK)	250 mK
Temperature measurement range	-20 °C to +550 °C (-4 °F to 1022 °F)		-20 °C to +450 °C (-4 °F to 842 °F)	-20 °C to +350 °C (-4 °F to 662 °F)		-20 °C to +250 °C (-4 °F to 482 °F)	-10 °C to +250 °C (+14 °F to +482 °F)
Frame rate	30 Hz or 9 Hz	TiS65 (30 Hz or 9 Hz) TiS60 (9 Hz)	TiS55 (30 Hz or 9 Hz) TiS50 (9 Hz)	TiS45 (30 Hz or 9 Hz) TiS40 (9 Hz)	9 Hz		8 Hz
Software	SmartView® software and Fluke Connect® ¹						SmartView® software
Documentation features	IR-PhotoNotes™ (3 images), voice annotation		IR-PhotoNotes™ (1 image), voice annotation	Voice annotation	-		
Video recording	Standard and radiometric		-				
Streaming video (remote display)	Yes, to SmartView® software on a PC or to the Fluke Connect® app on a smartphone		-				
Remote control	-						
Alarms	High temperature, low temperature, time lapse - auto image capture, and isotherms (within range)			High temperature, low temperature, time lapse - auto image capture	-		High/low temperature alarms, time-lapse image capture, auto-monitor alarm

¹Within your provider's wireless service area; Fluke Connect is not available in all countries.

INFRARED TOOLS



TiX560/520/500

See our **NEW** products on page 14!

Fluke Expert Series: TiX560/520/500

Stunning images and industry's largest screen

Navigate over, under and around hard-to-reach objects with a full 240 degree rotating lens. Easily view, annotate, edit and analyze images on the large tablet-like screen. Get advanced analytics such as streaming IR data and trend analysis.

- Easily navigate over, under and around objects with the 240° articulating lens
- MultiSharp™ Focus (TiX560/520/500) gives you clear, accurate focus throughout the field of view in one image, by capturing multiple images from varying focal distances
- LaserSharp® Auto Focus gives you the fastest way to precisely focused images by calculating the distance to your target with a laser distance meter¹
- Capture spectacular images close up or from a distance with interchangeable smart lenses—2x and 4x telephoto, wide angle, and 25 micron macro
- Get premium in-field viewing with the 5.7 inch touchscreen LCD, the largest in its class

¹Compared to industrial infrared cameras without a user-designated laser-focus feature.

Ordering information

Models	Included accessories
FLK-TiX560 9Hz or 60Hz Infrared Camera; 320 x 240	AC power supply; battery pack charger (including universal AC adapters); two rugged lithium ion smart battery pack; USB cable; HDMI video cable; micro SD card; rugged, hard carrying case; adjustable neck and hand straps and quick start guide; Bluetooth headset (where available)
FLK-TiX520 9Hz or 60Hz Infrared Camera; 320 x 240	
FLK-TiX500 9Hz or 60Hz Infrared Camera; 320 x 240	

Lens compatibility

Models	Lenses
TiX560/520/500	FLK-LENS/TELE2; FLK-LENS/4XTELE2; FLK-LENS/WIDE2; FLK-LENS/25MAC2

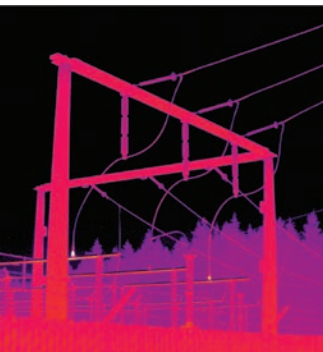

Apparent hot spots in electrical equipment.

Get tough shots from any angle with a 240° degree rotating lens and the only 5.7 inch LCD in its class (TiX560/520/500).

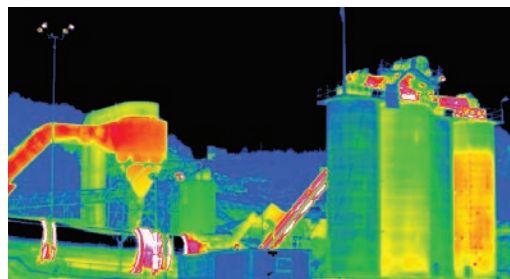

Fluke Professional Series: Ti450/400/300

100 % Focused. Every object.

Get clear, accurate focus on objects near and far with MultiSharp™ focus, or focus with laser speed and accuracy on your designated target with LaserSharp® Auto Focus. Easily navigate the menu and view images on a 3.5 inch, 640 x 480 touchscreen.

- Get 4x the pixel data with SuperResolution, which captures multiple images and combines them to create a 640 x 480 image (Ti450)
- Inspect high-temperature components, up to 1200 °C (2192 °F)¹
- Digitally document critical information with your infrared image using IR-PhotoNotes™, voice annotation, or text annotation
- Monitor processes with video recording, live video streaming, remote control¹, or auto capture

¹Features vary by model.

Ordering information

Models	Included accessories
FLK-Ti450 9Hz or 60Hz Infrared Camera	Infrared camera with standard infrared lens; ac power supply and battery pack charger (including universal ac adapters); two rugged lithium ion smart battery packs; USB cable; HDMI video cable; 4GB micro SD card; rugged, hard carrying case; soft transport bag and adjustable hand strap and quick start guide
FLK-Ti400 9Hz or 60Hz Infrared Camera	
FLK-Ti300 9Hz or 60Hz Infrared Camera	

Lens compatibility

Models	Lenses
Ti450/400/300	FLK-LENS/TELE2; FLK-LENS/4XTELE2; FLK-LENS/WIDE2

Expand the capabilities of your infrared camera

Software for Fluke Infrared Cameras

Analyze images, adjust blending and palette, export to multiple file formats, and create professional reports with Fluke SmartView® desktop software, downloadable for free from the Fluke website, or the Fluke Connect® mobile app for your smartphone. The Fluke Connect® app also enables you to wirelessly sync images directly from your camera to your smartphone, where you can email images to colleagues and attach them to an asset record or work order.

Lenses and other accessories

Capture images close up or from a distance with optional lenses, available for the Expert and Professional Series cameras.

All Fluke Professional and Performance Series cameras feature interchangeable batteries. Expand your powering capabilities with a car charger, extra battery, or charging base.

100% Focused—Every object. MultiSharp™

Go from being completely out of focus to:

100 % in focus with MultiSharp™ Focus, available on the Ti450.

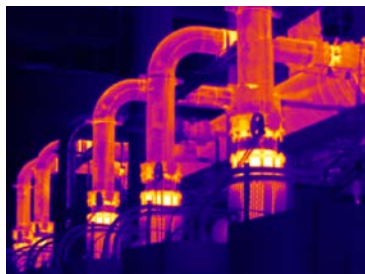
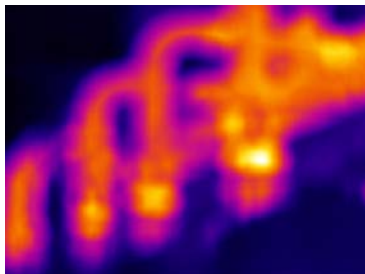

Built-in laser distance meter instantly calculates and displays the distance to your target.

Save time and instantly email images from the field with the Fluke Connect® app.



INFRARED TOOLS



Fluke Performance Series: TiS75/65/60/55/50/45/40/20/10



Easy-to-use frontline troubleshooting

Easily see potential problems with precisely blended IR and visual images—with a 5MP visual camera, up to 320 x 240 resolution, and a large 3.5 inch LCD. Get precise focus as close as 15 cm (6 in) with manual focus.

- With up to 320 x 240 resolution, you can see more detail in every image, even from a distance—detail that could indicate a potential issue
- Get the context of the visual and infrared details all in one precisely blended or picture-in-picture image with IR-Fusion® technology¹
- Reduce the amount of time it takes to get an in focus image with manual or fixed focus options
- Make decisions in real time—wirelessly sync images from your camera, create and email reports all with your smart phone and the Fluke Connect® App.
- Wirelessly connect to other Fluke Connect tools and pull in other measurements types like electrical and vibration into your thermal image.
- Removable 4GB micro SD card
- Digitally document critical information with your infrared image using IR-PhotoNotes™ or voice annotation³
- Monitor battery charge and avoid unexpected loss of power with the smart battery with LED charge indicator

¹IR-Fusion® and picture-in-picture mode execution varies by model

²Within your provider's wireless service area; Fluke Connect® is not available in all countries. Subscription to Fluke Connect® Assets is required in order to use the asset management and work order function

³Varies by model; see page 75 for model specifications



Inspect industrial components.

Designed for your environment.



Ordering information

Models	Included accessories
FLK-TiS75 30HZ Industrial Commercial Infrared Camera	Universal AC power adapter, lithium ion smart battery (TiS75, TiS65/60 includes 2 each—other models 1 each), USB cable, Micro SD card (TiS75, TiS65/60, TiS55/TiS50, TiS45), hard carrying case (TiS75, TiS65/60, TiS55/50, TiS45/40), soft transport bag, adjustable hand strap (TiS75, TiS65/60, TiS55/50, TiS45/40) and quick start guide. TiS75, TiS65/60 models include a two-bay battery charger.
FLK-TiS75 9HZ Industrial Commercial Infrared Camera	
FLK-TiS65 30HZ Industrial Commercial Infrared Camera	
FLK-TiS65 9HZ Industrial Commercial Infrared Camera	
FLK-TiS60 9HZ Industrial Commercial Infrared Camera	
FLK-TiS55 30HZ Industrial Commercial Infrared Camera	
FLK-TiS55 9HZ Industrial Commercial Infrared Camera	
FLK-TiS50 9HZ Industrial Commercial Infrared Camera	
FLK-TiS45 30HZ Industrial Commercial Infrared Camera	
FLK-TiS45 9HZ Industrial Commercial Infrared Camera	
FLK-TiS40 9HZ Industrial Commercial Infrared Camera	
FLK-TiS20 9HZ Industrial Commercial Infrared Camera	
FLK-TiS10 9HZ Industrial Commercial Infrared Camera	

Full infrared.

50 % blending, picture-in-picture mode

Picture-in-Picture.



Fluke VT04/VT04A Visual IR Thermometer

Designed to see it all

See issues in context by blending the infrared heat map with a visual image, and get the detail you need by choosing one of five on-screen blending modes. See aligned images from as close as 15 cm (6 in) in near mode or from a distance in far mode. Plus, obtain accurate temperature readings without taking your eyes off the screen. The center measurement box shows the exact area of temperature measurement. Fill that center box with your target and rest assured you're not measuring the background.

- Identify intermittent problems by monitoring equipment over time or get alerts when a temperature is outside the expected range with temperature alarms and automated monitoring features
- Instantly identify the hottest and coldest spots within the field of view with hot and cold markers
- Handy when you need it; easily fits in your tool bag or pocket
- Intuitive enough to use right out of the box
- Easily access saved images with the removable SD card



Fluke IR Windows CV400/401/300/301/200 CLKT100/75/50

Increase the safety and speed of your electrical infrared inspections

A company's greatest investment is not the equipment that's behind the panel door. It's the electricians, engineers and inspectors who risk their lives every day doing their jobs.

- Highest arc blast safety rating available—63 kA*
- Under 5 minute installation with 1 person; no need to remove panel door
- Clearly view equipment both visually and thermally with ClirVu® coating that protects the optic from the elements
- Corrosion and UV resistant for challenging outdoor environments—IP67 rugged*

* CV Series only

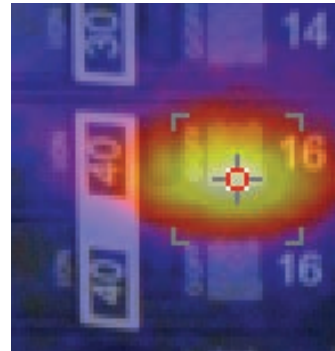

50% blended heat map.



Ordering information

Models	Included accessories
FLK-VT04A Visual IR Thermometer	Soft case, micro-SD card, micro-SD conversion adapter to standard, AA batteries (4), quick reference guide
FLK-VT04 Visual IR Thermometer	Hard case, micro-SD card, micro-SD conversion adapter to standard, lithium-ion rechargeable battery, micro USB charger/power supply (including worldwide adapters), quick reference guide

Ordering information

Models	Included accessories
CV400 4 in (95 mm) IR Window, Hand Turn Door Latch	Fluke IR Windows are supplied complete, assembled and ready for installation. In addition to the IR Window, each carton contains warranty statement and security key if that option is ordered.
CV401 4 in (95 mm) IR Window, Security Key Door Latch	
CV300 3 in (75 mm) IR Window, Hand Turn Door Latch	
CV301 3 in (75 mm) IR Window, Security Key Door Latch	
CV200 2 in (50 mm) IR Window, Hand Turn Door Latch	
FLK-100-CLKT 4 in (100mm) C-Range IR Window, Kwik Twist	Fluke IR Windows are supplied complete, assembled and ready for installation. In addition to the IR Window, each carton contains warranty statement
FLK-075-CLKT 3 in (75mm) C-Range IR Window, Kwik Twist	
FLK-050-CLKT 2 in (50mm) C-Range IR Window, Kwik Twist	

Fluke IR Windows enable you to inspect electrical equipment without opening panel doors.



VISUAL IR THERMOMETERS



CE

Fluke infrared thermometers: 62 MAX+, 62 MAX, 59 MAX and 572-2

Take measurements from a safe distance

Fluke has built infrared thermometers with the durability and accuracy you need to do your job, and all within your budget. These IR Thermometers offer precise laser technology for accurate and repeatable measurements.

Fluke 62 MAX+ highlights:

- Three-meter drop tested
- 12:1 distance to spot ratio
- Min/Max/Avg/Dif, Hi and Lo alarms
- Dual lasers for superior targeting

Fluke 62 MAX highlights:

- Single laser targeting
- 10:1 distance to spot ratio

Fluke 59 MAX highlights:

- 8:1 distance to spot ratio
- Min/Max/Avg/Dif, Hi and Lo alarms

Fluke 59 Max+ highlights:

- 10:1 distance to spot ratio
- Min/Max/Avg/Dif, Hi/Lo alarms

Specifications

	62 MAX+	62 MAX	59 MAX+	59 MAX
Temperature range	-30 °C to 650 °C (-22 °F to 1202 °F)	-30 °C to 500 °C (-22 °F to 932 °F)	-30 °C to 500 °C (-22 °F to 932 °F)	-30 °C to 350 °C (-22 °F to 662 °F)
Accuracy	± 1.0 °C or ± 1.0 % of reading, whichever is greater -10 °C to 0 °C: ± 2.0 -30 °C to -10 °C: ± 3.0	± 1.5 °C or ± 1.5 % of reading, whichever is greater -10 °C to 0 °C: ± 2.0 -30 °C to -10 °C: ± 3.0	0 °C: ± 1.5 °C or ± 1.5 % of reading, whichever is greater	≥ 0 °C: ± 2.0 °C or ± 2.0 % of reading, whichever is greater
Emissivity			0.10 to 1.00	0.10 to 1.00
Power	AA battery			
Compliance	EN/IEC 61010-1: 2001			
Laser safety	FDA and EN 60825-1 Class II			



CE

Fluke 572-2 Thermometer

- Extremely wide measurement range from -30 °C to 900 °C (-22 °F to 1652 °F)
- 60:1 distance to spot ratio with dual laser sighting

Fluke 50 Series II Thermometers

Lab accuracy in a field thermometer

- Laboratory accuracy: ± (0.05 % + 0.3 °C)
- Large backlit dual display, in °C, °F, or Kelvin (K)
- Min/Max/Avg
- Supports a wide range of thermocouple types

Powerful data logging capabilities

The Fluke 53 II B and 54 II B can log up to 500 points of data to internal memory.

- User-adjustable recording intervals
- Real-time clock captures the exact event time
- Download data to optional FlukeView® PC software



CE

Ordering information

Models	Included accessories
FLUKE-62 MAX+ Infrared Thermometer, Dual Lasers	
FLUKE-62 MAX Infrared Thermometer, Single Laser	Instruction sheet, battery
FLUKE-59 MAX Infrared Thermometer	
FLUKE 572-2 High Temperature Infrared Thermometer	K-type thermocouple bead probe, durable hard case, USB 2.0 computer interface cable
FLUKE-54-2-B Datalogging Thermometer, Dual Input	Bead thermocouple(s), batteries, overview manual, instructional guide on CD
FLUKE-53-2-B Datalogging Thermometer, Single Input	
FLUKE-52-2 Digital Thermometer, Dual Input	Bead thermocouple(s), batteries, overview manual, instructional guide on CD
FLUKE-51-2 Digital Thermometer, Single Input	



VISUAL IR THERMOMETERS

Fluke 560 Series Infrared Thermometers

Stand up to tough industrial, electrical, HVAC, and mechanical environments

With a straight-forward user interface and soft-key menus, the Fluke 560 Series IR Thermometers make even complex measurements easy. With just a few pushes of a button you can easily adjust emissivity, record data, or turn on and off alarms.

- Measure up to 800 °C (1470 °F)
- Easily access advanced features with the soft-key buttons and graphical display
- Scan large areas or small objects; measure smaller objects from further away
- Compatibility with most type K thermocouples
- Confidently measure more surfaces, with adjustable emissivity and built-in materials table
- Log and download measurements for reporting (568)
- Audible and visual alarms alert you to measurements outside of set limits
- Pipe probe for superheat and sub-cooling; other contact and ambient measurements (561)
- Min/Max/Avg/Dif functions
- Includes KTC bead probe
- 1 % measurement accuracy



CE



CE

Specifications

	Fluke 561	Fluke 566	Fluke 568
Infrared temperature range	-40 °C to 535 °C (-40 °F to 995 °F)	-40 °C to 650 °C (-40 °F to 1202 °F)	-40 °C to 800 °C (-40 °F to 1472 °F)
Accuracy	Greater of ± 1 % or ± 1 °C (2 °F)		
Distance to Spot (D:S)	12:1	30:1	50:1
Sighting	Laser point		
Typical distance to target	Up to 2.5 m (7 ft)	Up to 4.5 m (15 ft)	Up to 7.5 m (25 ft)
Probe type	Thermocouple K		
Contact temperature range	-40 °C to 550 °C (-40 °F to 1022 °F)		-270 °C to 1372 °C (-454 °F to 2501 °F)
Number of on-board memory locations		20	99
PC download and software			Yes, with FlukeView® Forms
Soft-key feature menu navigation			•
Min/Max/Avg/Dif	Min/Max/Dif		Min/Max/Avg/Dif
Material type adjustment (emissivity)	Hi/Med/Lo		Material table or 0.1 to 1.00 by 0.01
High and low alarms			High and low alarms
Hands-free logging			•
Battery		2 AA	
Warranty		Two-year	



Ordering information

Models	Included accessories
FLUKE-568 Infrared Thermometer	USB cable, FlukeView® Forms software, thermocouple type K bead probe, carrying case, two AA batteries, users manual, quickstart guide
FLUKE-566 Infrared Thermometer	Thermocouple type K bead probe, carrying case, two AA batteries, users manual and quickstart guide
FLUKE-561 Infrared Thermometer	Thermocouple type K pipe probe, carrying case, two AA batteries, users manual
FLUKE-61 Infrared Thermometer	9 V battery, instruction sheet
FLUKE-63 Infrared Thermometer	Wrist strap, carrying case, 9 V battery, users manual

The 568 allows for temperature measurement of small components.

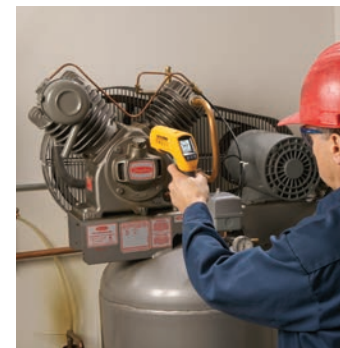

Fluke 830 Laser Shaft Alignment Tool

The ideal test tool to precision-align rotating shafts in your facility

The Fluke 830 Laser Shaft Alignment tool is easy-to-use, giving you fast, accurate and actionable answers that will keep your plant up and running. When it comes to laser shaft alignment, data is good but answers are better.

Unlike using the straightedge method or dial indicators, the Fluke 830 performs the complicated alignment calculations for you, meaning you'll have the answers you need to quickly align your machine and get your plant up and running fast. An enhanced user interface provides easy to understand results that don't require extensive alignment knowledge, and the unique "All-in-One" result screen shows you both coupling results and feet corrections (vertical and horizontal) in real terms making it easy to take corrective action.

- Single laser measurement technology means reduced errors from backlash resulting in better data accuracy
- Intuitive guided user interface quickly and easily complete machine alignments
- Compass measurement mode enables flexible, reliable and repeatable measurements using an active electronic inclinometer
- Dynamic machine tolerance check provides continuous evaluation of alignment adjustments so you know when your machine is in the acceptable range
- Unique extend mode handles gross misalignment by virtually increasing laser detector size
- Data protection ensures your data is there when you need it with auto save and resume capability

Specifications

Computer	
CPU	Intel XScale PXA270 running at 312 MHz
Memory	64 MB RAM, 64 MB flash
Display	TFT, transmissive (sunlight-readable), 65,535 colors, backlit LED Resolution: 320 x 240 pixel; Dimensions: 89 mm (3.5 in) diagonal
LED indicators	Multicolor LED for laser status, alignment condition and battery status
Power supply	Integrated lithium-ion polymer rechargeable battery: 7.4 V/2.6 Ah
External interface	USB host and USB device (slave), integrated wireless communication, Class 1, transmitting power 100 mW, RS-232 (serial) for sensor, AC adapter/charger socket
Environmental protection	IP65 (dustproof, water spray resistant), shockproof, relative humidity 10% to 90%
Sensor	
Measurement principle	Coaxial, reflected laser beam
Laser	Type: Ga-Al-As semiconductor laser Wavelength (typical) 675 nm (red, visible) Safety class: Class 2, FDA 21 CFR 1000 and 1040 Beam power: < 1 mW
Detector	Measurement area: unlimited, dynamically extendible (U.S. Patent 6,040,903) Resolution: 1 µm; Accuracy (avg): > 98%
Inclinometer	Measurement range: 0° to 360°; Resolution: <1°
Environmental protection	IP67 (submersible, dustproof)
Prism	
Type	90° roof prism; Accuracy (avg): > 99%
Environmental protection	IP67 (submersible, dustproof)

Rotate the shaft and receive instant measurement verification.



Ordering information

Models	Included accessories
FLUKE-830 Laser Shaft Alignment Tool	Laser sensor, laser prism, chain-type mounting bracket with 150 mm support posts 2x, 300 mm support post 4x, micro fiber cleaning cloth, sensor cable, PC cable, USB drive, USB drive cable, tape measure, wireless Bluetooth® module, power adapter, instruction kit, and carrying case

Fluke 820-2 LED Stroboscope

Ideal for stop motion diagnostics and frontline mechanical troubleshooting

The Fluke 820-2 LED Stroboscope lets you confidently investigate and observe potential mechanism failure on a variety of machinery, in a wide range of industries, without making physical contact with the machine, or shutting the machine down. The Fluke 820-2 is rugged, compact and easy-to-use making it the ideal portable strobe for stop motion diagnostics, mechanical troubleshooting and process or product research. Use stop motion diagnostics to identify the running speed of rotating equipment, identify part numbers or other markings, measure the speed of rotation or frequency of a rotating shaft, speaker, or mechanical part, troubleshoot belt drive machines and much more!

- High intensity 7-LED array—4,800 Lux @ 6,000 FPM/30 cm
- High efficiency LED solid-state light source with uniform flash characteristics allow for higher flash rates—30 FPM to 300,000 FPM (flashes per minute)
- Digital pulse width modulation for exceptionally sharp images at high speeds
- Rugged, durable design utilizes solid-state LEDs with no filaments, gases, hollow cavities, or glass—(one meter drop)
- Quartz-accuracy control system provides high accuracy—0.02 % (± 1 digit)
- Multi-line LCD display
- Check the rotating speed of machinery without physical contact or need for reflective tape
- Advance or retard flash timing for viewing gear teeth, cutting surfaces, repeats, or “drifting” equipment
- Simple push button operation with 2x and ÷2 buttons for easy adjustment



Specifications

Flash frequency	
Range	30 to 300,000 FPM 0.5 to 5000 Hz
Accuracy	0.02 %
Resolution	30 to 999 FPM = 0.1 1000 to 300,000 = 1 0.5 Hz to 999 Hz = 0.1 1000 Hz to 5000 Hz = 1
Frequency setting	FPM or Hz
External trigger	
Method	Connector to externally control trigger
High level	3 V to 32 V
Low level	< 1 V
Minimum pulse width	50 µs connection
Safety compliance	
Agency approvals	CE Class III (SELV) Pollution Degree 2
Impact resistance	1 m drop
Mechanical specifications	
Size (HxWxL)	5.71 cm x 6.09 cm x 19.05 cm (2.25 in x 2.4 in x 7.5 in)
Weight	0.24 kg (0.53 lb)

Ordering information

Models	Included accessories
FLUKE-820 LED Stroboscope	Protective case and external trigger connector

Identify running speeds using stop motion diagnostics.



Fluke 810 Vibration Tester

Get mechanical maintenance answers now!

The Fluke 810 Vibration Tester is the most advanced diagnostic tool for mechanical maintenance teams who need to keep machines up and running. The Fluke 810 is engineered to provide machine condition answers and evaluate the most common mechanical problems.

The Fluke 810 Vibration Tester uses a simple 3-step process to report on machine faults the first time measurements are taken, without prior machine history. To locate and diagnose common mechanical problems and prioritize repair actions, use these three simple steps: set-up with basic machine information; measure to quickly troubleshoot problems or monitor machine condition; and diagnose and identify the root cause, location and severity.

Use the Fluke 810 to:

- Easily determine the root cause, location and severity of common mechanical faults
- Efficiently prioritize and plan equipment repair or replacement
- Effectively deploy maintenance resources at the point of greatest impact



Viewer PC Software

- Store and track your data
- Generate diagnostic reports and track the severity of your machine's condition
- Import and store JPEG images

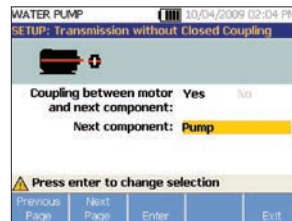

1. Setup

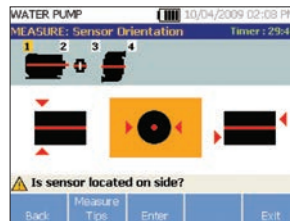

2. Measure

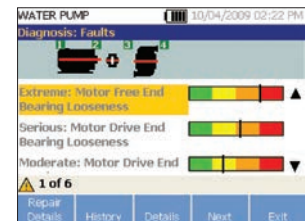

3. Diagnose

Specifications

Diagnostic specifications	
Analysis for	Motors, fans, blowers, belts and chain drives, gearboxes, couplings, centrifugal pumps, piston pumps, sliding vane pumps, propeller pumps, screw pumps, rotary thread/gear/lobe pumps, piston compressors, centrifugal compressors, screw compressors, closed coupled machines, spindles
Standard faults	Unbalance, looseness, misalignment and bearing failures
Motor rotational speed range	200 rpm to 12000 rpm
Diagnosis details	Plain-text diagnosis, fault severity (slight, moderate, serious, extreme), repair details, cited peaks, spectra
Tester specifications	
IP rating	IP54
A/D converter	4 channel, 24 bit
Dynamic range	128 dB
FFT resolution	800 lines
Battery	Lithium-ion, rechargeable, 8 hours operating life
Onboard storage capacity	2 GB internal + user accessible slot for additional storage
Warranty	Three-year (tester), One-year (sensor and tachometer)
Sensor specifications	
Sensor type	Tri-axial accelerometer , 100 mV/g (± 5 %, 25 °C)
Tachometer specifications	
Tachometer type	Laser Diode Class 2

Ordering information

Models	Included accessories
FLUKE-810 Vibration Tester	Tri-axial accelerometer, magnet mount, mounting pad kit with adhesive, quick-disconnect accelerometer cable, laser tachometer with storage pouch, battery pack with cable and adapters, shoulder strap, adjustable hand strap, Viewer PC software, mini USB to USB cable, carrying case, training DVD, getting started guide, quick reference guide, and users manual on DVD



Fluke 805 FC Vibration Meter

Forget the pens. Think METER.

The Fluke 805 FC Vibration Meter is the most reliable vibration screening device available for frontline mechanical troubleshooting teams who need repeatable, severity-scaled readings of overall vibration and bearing condition.

- 5 tools in 1: Overall vibration, bearing impacting, temperature, machine health severity, and bearing health severity
- Get authorization to take next steps in an instant if machine health is at risk via Fluke Connect®
- Four-level severity scale assesses urgency of vibration problems
- Vibration measurement for acceleration, velocity, and displacement units of measurement
- Colored lighting system (green, red) and on-screen comments indicate how much pressure needs to be applied to take measurements
- Non-contact temperature measurement increases machine health screening capabilities
- External accelerometer support for hard to reach locations

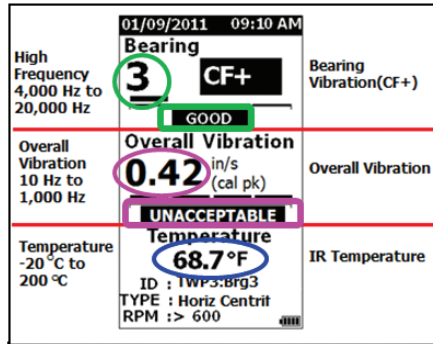

Specifications

Vibration meter	
Low frequency range (overall measurement)	10 Hz to 1,000 Hz
High frequency range (CF+ measurement)	4,000 Hz to 20,000 Hz
Severity levels	Good, Satisfactory, Unsatisfactory, Unacceptable
Vibration limit	50 g peak (100 g peak-peak)
A/D converter	16-bit
Sampling rate	Low frequency: 20,000 Hz; high frequency: 80,000 Hz
Sensor	
Sensitivity	100 mV/g ± 10%
Measurement range	0.01 g to 50 g
Low frequency range (overall measurement)	10 Hz to 1,000 Hz
High frequency range (CF+ measurement)	4,000 Hz to 20,000 Hz
Resolution	0.01 g
Accuracy	At 100 Hz ± 5% of measured value
Amplitude units	
Acceleration	g, m/sec ²
Velocity	in/sec, mm/sec
Displacement	mils, mm
Infrared thermometer (temperature measurement)	
Range	-20 °C to 200 °C (-4 °F to 392 °F)
Accuracy	± 2 °C (4 °F)
Focal length	Fixed, at ~3.8 cm (1.5 in)
Environmental	
IP rating	IP54
Drop test	1 meter

What is Crest Factor+?

Crest Factor (CF) is used to identify bearing faults and is the ratio of the peak value/RMS value of a time domain vibration signal. As the bearing condition worsens, the CF+ value increases. Fluke has also included a four-level severity scale that identifies the bearing health.

More than an overall vibration meter— 5 tools in 1

1. Low frequency vibration meter
2. High frequency vibration meter (bearings)
3. IR temperature meter
4. Machine health screening tool (37 machine categories)
5. Bearing health screening tool

Ordering information

Models	Includes
FLUKE-805 FC Vibration Meter	USB cable, storage case, belt holster, quick reference guide, (includes MS Excel template and documentation), and two AA batteries
FLUKE-805ES External Sensor	External vibration sensor with threaded mounting bolt, removable "U" shaped magnet mount, and 2.1336 m (7 ft) coiled cable

Fluke cases and holsters

A premium meter deserves a premium case

Soft cases

CAMO-C25 Camouflage Carrying Case

- High quality 1000D fabric
- Dimensions (HxWxD): 20.3 x 12.1 x 4.6 cm (8 x 4.8 x 1.8 in)



CAMO-C37 Camouflage Carrying Case

- High quality 1000D fabric
- Dimensions (HxWxD): 26.5 x 9 x 3 cm (10.5 x 3.5 x 1.2 in)



C75 Accessory Case

- Zippered carrying case
- Dimensions (HxWxD): 17.9 x 10.3 x 2.6 cm (7 x 4 x 1 in)



C50 Meter Case

- Case with inside pocket, belt loop and inside meter strap
- Dimensions (HxWxD): 19.2 x 9 x 3.8 cm (7.56 x 3.5 x 1.5 in)



C25 Large Soft Case for DMMs

- Case with padding and inside pocket
- Dimensions (HxWxD): 21.8 x 12.8 x 6.4 cm (8.6 x 5 x 2.52 in)



C90 Soft Case for DMMs

- Case with inside pocket and belt loop
- Dimensions (HxWxD): 20.5 x 9 x 7.2 cm (8 x 3.5 x 2.8 in)



C35 Soft Carrying Case

- Made of durable polyester 600D
- Dimensions (HxWxD): 22 x 14 x 6.5 cm (8.7 x 5.5 x 2.6 in)



C23 Soft Carrying Case

- Case with inside pocket and belt loop
- Dimensions (HxWxD): 22.5 x 9.5 x 5.8 cm (8.9 x 3.75 x 2.3 in)



C280 Soft Case

- Made of durable polyester 600D
- Dimensions (HxWxD): 23 x 18.5 x 6.5 cm (9 x 7.3 x 2.6 in)



C115 Soft Carrying Case

- Made of durable polyester 600D
- Dimensions (HxWxD): 24 x 20.5 x 7.5 cm (9.5 x 8 x 3 in)



C116 Soft Carrying Case

- Made of durable polyester 600D
- Dimensions (HxWxD): 24 x 23 x 6.5 cm (9.5 x 9 x 2.6 in)



C150 Soft Carrying Case

- High quality 1000D fabric
- Dimensions (HxWxD): 29.8 x 11.4 x 5.6 cm (11.75 x 4.5 x 2.2 in)



C781 Meter Case

- Made of durable polyester 600D
- Dimensions (HxWxD): 26.9 x 14.1 x 9 cm (10.6 x 5.6 x 3.5 in)



C33 Soft Carrying Case

- Case with inside pocket and belt loop
- Dimensions (HxWxD): 28 x 11.5 x 5.5 cm (11 x 4.5 x 2.2 in)



C789 Meter and Accessory Case

- Made of durable polyester 600D
- Dimensions (HxWxD): 30.8 x 25.6 x 7.7 cm (12 x 10 x 3 in)



C43 Soft Carrying Case

- Made of durable polyester 600D
- Dimensions (HxWxD): 31.8 x 23 x 9 cm (12.5 x 9.1 x 3.5 in)



C550 Tool Bag

- Made of ballistic cloth with heavy-duty hardware
- Dimensions (HxWxD): 33.3 x 51.3 x 23.1 cm (13 x 20.2 x 9.1 in)



C345 Soft Case

- Made of durable polyester 600D
- Dimensions (HxWxD): 36 x 20 x 24 cm (14 x 8 x 9.5 in)



Fluke cases and holsters

A premium meter deserves a premium case

Hard cases

CXT Series Extreme Cases

- Models CXT80, CXT170, and CXT280 for various meter compatibility
- Unbreakable, watertight, airtight, chemical resistant and corrosion proof



C101 Hard Case

- Dimensions (HxWxD): 30.5 x 36 x 10.5 cm (12 x 14.2 x 4.1 in)



C100 Universal Carrying Case

- Dimensions (HxWxD): 39.7 x 34.6 x 12.2 cm (15.7 x 13.6 x 4.8 in)



C1600 Gear Box

- Includes five hook and loop straps to wrap cords and test leads
- Dimensions (HxWxD): 26 x 39 x 20 cm (10 x 15 x 7.8 in)



CXT1000 Extreme Hard Case - New

- Rugged hard case that allows you to configure the diced foam interior and offers maximum protection
- Waterproof to a depth of 3 feet, airtight, and O-ring sealed for automatic pressure equalization
- Dimensions (HxWxD): 34.3 x 46.5 x 17.8 cm (13.5 x 18.3 x 7 in)



Leather cases

C520A Leather Tester Case

- Dimensions (HxWxD): 25.6 x 15.4 x 10.6 cm (10 x 6 x 4 in)



C510 Leather Meter Case

- Dimensions (HxWxD): 28.7 x 17.9 x 10.6 cm (11 x 7 x 4 in)



Holsters

H15 Electrical Tester Holster

- High quality 1000D fabric
- Dimensions (HxWxD): 27.9 x 9.2 x 5.1 cm (11 x 3.6 x 2 in)



H80M Protective Holster

- Includes a hanging magnet, general purpose hanger, and hook and loop straps
- Dimensions (HxWxD): 19 x 9.5 x 4.3 cm (7.5 x 3.7 x 1.7 in)



H5 Electrical Tester Holster

- Dimensions (HxWxD): 19.2 x 9 x 3.8 cm (7.5 x 3.5 x 1.5 in)



H3 Clamp Meter Holster

- Dimensions (HxWxD): 23.1 x 9 x 6.4 cm (9 x 3.5 x 2.5 in)



H6 IR Thermometer Holster

- Dimensions (HxWxD): 30.2 x 17.8 x 5.7 cm (11.9 x 7 x 2 in)



Fluke cases and holsters

A premium meter deserves a premium case

Cases and holsters selection guide

	113/114/115/116/117	27 II/28 II	77-4/175/177/179	83/97V	233	287/289	8845A/8846A/8808A	120/190/22X Series	51-1/52-II/53-II B/54-II B	561/566/568	63/66/68	323/324/325	355	365/373/902	374 FC/375FC /376 FC/381	705/707	712/714/715/717/72X Series	718/719	753/754	787/789	T+/T+PRO	T5-600/T5-1000	1603/1507/1577/1587 FC
C12A	•															•							
C23	•																						
Camo-C25	•	•	•	•	•	•			•								•			•	•		•
C25	•	•	•	•	•	•																	•
C33				•																			
C35				•	•																		
Camo-C37														•	365	•							•
C43				•	•	•		•		•													
C50	•																						
C75	The C75 is designed to hold test leads, probes, clips and other required accessories																						
C90	•		•						•														•
C100		•	•	•						•							71X			787			
C101	•	•	•	•	•	•		•	•														•
C115/C116	•	•	•	•	•	•		•						•	365	•	•	•		•			•
C125		•	•	83V	•																		
C150														•	•								•
C280	•	•	•	•	•	•		•	•								•	•	•	•	•		
C345	The perfect case for carrying a wide range of Fluke handheld test tools and accessories																						
C510			•						•					•	•					787			
C520A																						•	•
C550/C1600	The C550 and C1600 are large enough to hold accessories and multiple test tools																						
C781						•	•										72X	•	•	789			•
C789							•							•	365								•
C799																				•			
C800			•	•																			
CXT80		•	•	•	•												71X			787			
CXT170	•		•														72X						
CXT280						•											71X						•
CXT1000	The CXT1000 is designed to store, carry, and protect a wide range of Fluke test tools and accessories																						
H15																						•	•



Fluke accessory sets and kits

Get an outstanding value with our most popular accessories

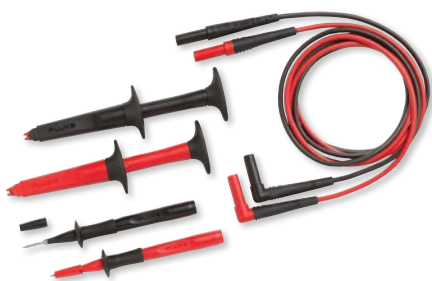

TL220-1 Industrial Test Lead Set

- Starter kit for industrial applications
- Includes 1 pair: AC220, TP220, TL224
- CAT II 1000 V, 10 A (TP220 only)
- CAT III 1000 V, CAT IV 600 V with protective cap

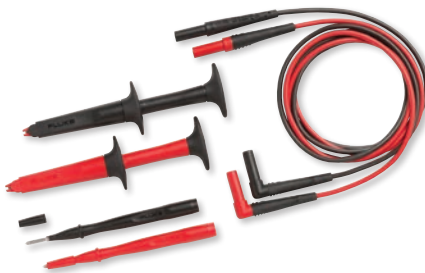

TL223-1 Electrical Test Lead Set

- Starter kit for electrical applications
- TP1 has flat blades for wall sockets
- Includes 1 pair: AC220, TP1, TL224
- CAT II 1000 V, 10 A (TP1 only)
- CAT III 1000 V, CAT IV 600 V with protective cap



TLK-220 EUR SureGrip™ Accessory Kit with Meter Carrying Case

- Plunger style alligator clips
- Large jaw alligator clips
- Sharp test probes
- Right to straight test leads
- Zippered vinyl carry case with moveable divider
- Holds large DMMs



TLK287 Electronics Master Test Lead Set

The perfect test lead kit for today's electronics test and design.

- Precision electronic probes with multiple spring-loaded sharp tips to maximize contact with SMD test points
- Micro-grabbers and leads to enable fine SMD test
- Modular mini-alligator clips, grabbers, leads, probes, and couplers EN61010 for virtually every electronics need



TLK289 EUR Industrial Master Test Lead Set and Case

Designed for electrical and electronics test in today's industrial environment.

- SureGrip™ alligator clips, grabbers and hook clips for dependable contact with a variety of test points
- TP175 TwistGuard™ Test Probes
- Magnetic hanger for suspension of your DMM
- Temperature adapter with type K thermocouple for direct temperature measurement with your DMMs



TLK-225-1 SureGrip™ Master Accessory Kit

- TP175 TwistGuard™ Test Probes
- Plunger style alligator clips
- Plunger style hook clips
- Plunger style pincer clips
- Large jaw alligator clips
- Right to straight test leads
- Six-pocket storage pouch, keeps the entire set together

Test lead kits selection guide

	113/114/115/116/117	27 II/28 II/27	77 IV	175/177/179	83V/87V/233	287/289	434/435	8845A/8846A/8808A	120 Series	190 Series	225C	323/324/325	355	365/373	374 FC/376 FC/378 FC/381	902 FC	705/707	71X Series	724/725/726	753/754	787/789	T+/T+Pro	T5-600/T5-1000	1503/1507/1577/1587 FC
TLK287	•	•	•	•	•	•	•	•	•	•	•	•	•	•	•	•	•	•	•	•	•	•	•	•
TLK289 EUR	116	•	•	•	•	•	•	•	•	•	•	•	•	•	•	•	•	•	•	•	•	•	•	•
TL220-1	•	•	•	•	•	•	•	•	•	•	•	•	•	•	•	•	•	•	•	•	•	•	•	•
TL223-1	•	•	•	•	•	•	•	•	•	•	•	•	•	•	•	•	•	•	•	•	•	•	•	•
TL225-1	•	•	•	•	•	•	•	•	•	•	•	•	•	•	•	•	•	•	•	•	•	•	•	•
TL238	•	•	•	•	•	•	•	•	•	•	•	•	•	•	•	•	•	•	•	•	•	•	•	•
TL80A-1	•	•	•	•	•	•	•	•	•	•	•	•	•	•	•	•	•	•	•	•	•	•	•	•
TL81A	•	•	•	•	•	•	•	•	•	•	•	•	•	•	•	•	•	•	•	•	•	•	•	•
80K-8, 80K-15, 80K-40	dc only	•	•	•	•	•	•	•	•	•	•	•	•	•	•	•	•	•	•	•	•	•	•	•



T5-Kit-1, Tester Starter Kit

Getting started kit for electricians who already own a Fluke T5 Tester.

- Test probes
- Large jaw alligator clips
- Zippered soft case

Fluke test leads, probes and clips

The best leads for all your measurement needs

For electronic applications



TL80A-1 Basic Electronic Test Lead Set

- Six piece set with zippered case
- Probes, alligator clips and tip extenders for electronic applications
- CAT II 300 V
- CAT III 1000 V, CAT IV 600 V with protective cap

TL910 Electronic Test Probes with Replacement Tips

- Small profile provides accessibility
- Comes with five sets of replaceable tips
- Replacement tips: TP912
- CAT II 1000 V, 3 A



TL912

Replacement Tips for TL910

- Replacement tips for TL910
- Five sets of gold plated and stainless steel tips

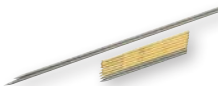

TP80 Electronic Test Probes

- Tapered tip ideal for probing electronic components or boards
- Removable guard for IC probing
- CAT III 1000 V, 10 A



TP920 Test Probe Adapter Kit

- IC test tip adapters, extended tips, medium alligator clips fit over TL71 and TL75 test lead sets
- IC test tip Adapter, 3 A
- Extended probe tip, 3 A
- Med. alligator clip, 5 A
- Rated 300 V, 5 A

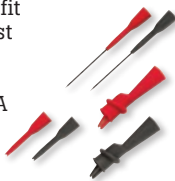

TLK290 Test Probe Kit

- Kit includes three flexible socket probes and a large alligator clip
- To be used on three phase sockets.
- Probes have flexible width test points that fit securely in 4 to 8 mm sockets.
- Test probe set to be used on motor and three phase sockets
- Safe contact e.g. in CEE 16 A and CEE 32 A plugs
- CAT II 1000 V, 8 A



TLK291 Fused Test Probe Set

- One pair (red, black) fused test probes
- Designed to meet GS38 specs for United Kingdom
- CAT III 1000V, 0.5A
- Fuse rating: 500 mA/1000 V/FF/50 kA



TL970 Hook and Pincer Kit

- TL940 Mini-Hook Test Lead Set
- TL950 Mini-Pincer Test Lead Set
- TL960 Micro-Hook Test Lead Set



TL81A Deluxe Electronic Test Lead Kit

- Includes components of TL80, plus one pair (red, black) each modular 1 meter long silicone test lead, test probe, hook-style and pinch style clip, alligator clip, IC probe tip adapter and spade lugs
- Quafold soft carrying case

TL40 Retractable Probe Assembly

- Retractable, insulated sharp probe tip
- CAT II 600 V, 3 A



TL940 Mini-Hook Test Lead Set

- 1 pair (red, black) of test leads with multi-stacking 4 mm banana plugs and mini-hooks
- Mini-hooks attach to component leads up to 1.5 mm diameter
- 90 cm long PVC insulated leads
- 30 V rms or 60 V DC, 5 A



TL950 Mini-Pincer Test Lead Set

- 1 pair (red, black) of test leads with multi-stacking 4 mm banana plugs and mini-pincers
- Mini-pincers open to 2.3 mm
- 90 cm long PVC insulated leads
- 30 V rms or 60 V DC, 5 A



TL960 Micro-Hook Test Lead Set

- 1 pair (red, black) of test leads with multi-stacking 4 mm banana plugs and micro-hooks
- Micro-hooks attach to component leads up to 1 mm diameter
- 90 cm long PVC insulated leads
- 30 V rms or 60 V DC, 15 A



TL930 Patch Cord Set (60 cm)

- 1 pair (red, black) multi-stacking 4 mm banana plug patch cords
- Nickel-plated banana plugs
- 60 cm long PVC insulated leads
- 30 V rms or 60 V DC, 15 A



TL932 Patch Cord Set (90 cm)

- 1 pair (red, black) multi-stacking 4 mm banana plug patch cords
- Nickel-plated banana plugs
- 90 cm long PVC insulated leads
- 30 V rms or 60 V DC, 15 A



TL935 Patch Cord Kit (60, 90, 120 cm)

- 3 sets (red and black pairs) of multi-stacking 4 mm banana plug patch cords
- Nickel-plated banana plugs
- 60 cm, 90 cm, 120 cm long PVC insulated leads
- 30 V rms or 60 V DC, 15 A



TL26A Telecom Test Lead Set

- Five-way multi-point test clips for telecommunications applications
- Flexible silicone insulated leads are heat and cold resistant
- Rated 30 V, 8 A



Fluke test leads, probes and clips

The best leads for all your measurement needs

For automotive applications

TP81 and TP82

- Stainless steel probe pierces insulation on 0.75 mm² to 2.00 mm² wire
- Design provides complete insulation while working on fuel injectors or sensors
- TP81 for use with modular test leads (Fluke TL224)
- TP82 slips over probe tips (Fluke TL71)
- Rated to 60 V dc



TP40 Automotive Back Probe Pin Set

- Set of five 38 mm (1.5 inch) pins
- Rated to 60 V dc
- Provide an easy connection past weather pack seals to connector conductors
- Use with Fluke TL71 or TL75 test lead sets



TL28A Automotive Test Lead Set

- Flexible silicone insulated leads are heat and cold resistant
- Rated 30 V, 10 A



TP88 Rigid Backprobe Pin Set

- 51 mm (2 inch) long pins pass between the weather pack seal and wire
- Use with Fluke TL71 or TL75 test lead sets
- Rated to 60 V dc



TL82 Automotive Pin & Socket Adapter Set

- Collection of male and female adapters allows you to make firm connection to pin and socket connectors
- Adapters with flexible tips come in the following sizes: 0.3 mm² to 3.3 mm²
- Rated to 60 V dc



BP980 Double Banana Plug Kit

- 5 pair (red, black) of double 4 mm banana plugs
- Each plug has 3.1 mm holes for mounting wires and components
- Brass plugs/jack, beryllium copper springs
- 30 V rms or 60 V DC, 15 A



TLK281 Automotive Test Lead Kit

- Insulation piercing probes
- SureGrip™ silicone test leads
- SureGrip test probes
- SureGrip plunger style alligator clips
- SureGrip alligator clips
- Carrying case



TLK282 Deluxe Automotive Test Lead Kit

- Insulation piercing probes
- Set of five automotive back probe pins
- SureGrip silicone test leads
- SureGrip test probes
- SureGrip plunger style alligator clips
- SureGrip alligator clips
- SureGrip hook clips
- Carrying case



High-voltage probes

80K-6, 80K-15, 80K-40 High Voltage Probes

- Allows a digital multimeter to measure up to 6,000 volts peak, 15,000 volts peak and 40,000 volts peak respectively
- 1000:1 division ratio output when connected to 10 MΩ multimeter
- Ground clip included
- Intended for low energy applications that are referenced to ground
- 80K-15 (not available in Europe)

Note: intended for low energy applications only



Fluke SureGrip™ accessories

As tough as your meter



Modular test leads and test probes (use test probes with test leads)

TP175, TwistGuard™ Test Probes

- Converts probe tip length between 4 mm, a CAT III 1000 V, CAT IV 600 V measurement and 19 mm, a CAT II 1000 V measurement
- Fits standard modular test leads



FTPL-1 SureGrip™ Fused Test Probes with Leads

- FTP-1 Fused Test Probes with built-in fuses for added protection
- TL224 Silicone Insulated Test Leads
- CAT III 1000 V, CAT IV 600 V, 10 A



TL221 SureGrip™ Silicone Test Lead Extension Kit

- Superior strain relief
- Includes two adapters to extend leads 1.5 m
- CAT III 1000 V, CAT IV 600 V, 10 A



TL222 SureGrip™ Silicone Insulated Test Leads

- Superior strain relief
- Recommended for use with AC220, AC280, AC283 test clips
- CAT III 1000 V, CAT IV 600 V, 10 A



TL224 SureGrip™ Silicone Insulated Test Leads

- Superior strain relief
- 1.5 m silicone-insulated wire resists heat and cold
- CAT III 1000 V, CAT IV 600 V, 10 A



TL27 Heavy Duty Test Lead Set

- DMM test leads (red, black) with safety shrouded, standard diameter banana plugs
- Heavy duty EPDM insulation
- Length 1.5 m
- CAT III 1000 V, 10 A



TL76 All-in-one Test Lead Set

- One pair (red, black) meter long silicone test leads with right angle shrouded banana plug
- Lantern tip (removable) for use with European wall sockets (4 mm Ø)
- Lantern tip can be removed for easy access to terminal blocks (2 mm Ø)
- Removable, insulated IC caps allow probing on closely spaced leads and compliance with GS38
- CAT IV 600 V, CAT III 1000 V, 10 A



FTP-1 SureGrip™ Fused Test Probes

- Built-in fuses for added protection
- 2 mm threaded probe tips include removable 4 mm lantern-style spring contacts
- Removable GS38 insulated caps
- CAT III 1000 V, CAT IV 600 V, 10 A



TP1, TP2, TP4 and TP38 Slim Reach™ Test Probes

- Slender probe bodies for probing closely spaced or recessed points
- TP1 has a flat blade
- TP2 has 2 mm diameter tip
- TP4 has 4 mm diameter tip
- TP38 has stainless steel insulated probe to help lessen the risk of arc flash explosion
- CAT II 1000 V, 10 A
- CAT III 1000 V, CAT IV 600 V with protective cap (TP1 and TP2 only)
- CAT III 1000 V, CAT IV 600 V (TP38 only)



TP74 Lantern Tip Test Probe Set

- One pair (red, black)
- Tips include banana-style spring contacts with nickel-plated brass ends
- CAT III 1000 V, 10 A



TP220-1 SureGrip™ Industrial Test Probes

- Sharp, 13 mm (.5 inch) stainless steel tip provides reliable contact
- Flexible finger barrier improves grip
- CAT II 1000 V, 10 A
- CAT III 1000 V, CAT IV 600 V with protective cap



Modular clips (use with test leads, includes one red, one black)

AC220 SureGrip™ Alligator Clips

- Insulated, nickel plated jaws grip objects up to 10 mm (.375 in)
- Blunt tip grabs round screw heads
- CAT III 1000 V, CAT IV 600 V, 10 A



AC280 SureGrip™ Hook Clips

- Profile narrows to 5.5 mm (.22 inch) at tip
- Hook opening 5 mm (.20 inch) at front, 2 mm (.08 inch) at base
- CAT III 1000 V, CAT IV 600 V, 3 A



AC283 SureGrip™ Pincer Clips

- 11.4 cm (4.5 inch) flexible, insulated shaft
- Nickel plated pincers open to 5 mm (.20 in)
- CAT III 1000 V, CAT IV 600 V, 1 A



AC285 SureGrip™ Alligator Clips

- Multi-purpose tooth pattern grips anything from fine gauge wire to a 19 mm (.75 in) nut
- Nickel-plated steel jaws
- Accepts standard modular 4 mm test leads
- CAT III 1000 V, CAT IV 600 V, 10 A



AC285-FTP Alligator Clips and Adapters for FTP-1 or FTPL-1

- Enhances the usage of your Fluke fused test leads with this large alligator clip set
- Enables the use of AC285 alligator clips with FTP-1 fused probes
- CAT III 1000 V, CAT IV 600 V, 10 A



AC87 Heavy Duty Bus Bar Clip Set

- One pair (red, black) of flat, right angle design for connecting to bus bars
- Adjustable collar provides 2 ranges of jaw openings up to 30 mm
- CAT III 600 V, 5 A





AC89 Heavy Duty Insulation Piercing Test Clip

- Single probe pierces 0.25 to 1.5 mm insulated wire
- Small pin allows self-healing of the insulation
- CAT IV 600 V, CAT III 1000 V, 5 A



AC175 Threaded Alligator Clips

- Threads securely onto TL175 or TP175 probes
- Insulated alligator clips with flexible boots
- Jaw opening: 7 mm (0.275 in), jaw contact material: nickel-plated steel
- CAT III 1000 V, CAT IV 600 V



AC173 Extended Tooth Alligator Clips

- Extended tooth jaw with front placement for attaching to screw heads
- Accepts standard 4 mm modular test leads
- Jaw opening: 8 mm (0.31 in), jaw contact material: nickel-plated steel
- CAT III 1000 V, CAT IV 600 V



The new standard for safety

TL175 TwistGuard™ Test Leads

- Probes meet new EN 61010-031 requirements for safety
- Patented extendable tip guard meets new CAT III 1000 V, CAT IV 600 V requirements while providing the flexibility you need for CAT II measurements
- **New WearGuard™** test lead wear indicator that changes color when leads are damaged and in need of replacement
- Probes always show correct category rating for tip being used
- Advanced strain relief exceeds 5,000 bend life
- TP175 probes fit modular test leads
- TL175E includes removable 4 mm lantern tips



TL238 SureGrip™ Test Lead Set for high energy environments

- Insulated tip probes help lessen risk of arc flash explosion
- Probe extenders keep hands away from live current
- Includes one pair each, insulated test tip probes, probe extenders and TL224 Test Leads
- Probes and leads CAT III 1000 V, CAT IV 600 V, 10 A, extenders CAT III 1000 V 10 A



TL71-1 Premium DMM Test Lead Set

- Flexible silicone insulated leads are heat and cold resistant
- Distinctive comfort grip probes
- Recommended for μ V measurements
- CAT II 1000 V, 10 A
- CAT III 1000 V, CAT IV 600 V with protective cap



TL75-1 Hard Point Test Lead Set

- Extremely hard alloy tips resist wear
- Distinctive comfort grip probes
- 1.5 m PVC leads
- CAT II 1000 V, 10 A
- CAT III 1000 V, CAT IV 600 V with protective cap



Fluke temperature accessories

Hot probes with cool designs



SureGrip™ temperature accessories

The innovative SureGrip™ design from Fluke is now available in select temperature probes. The soft rubber handle combined with a new ergonomic shape is so comfortable to hold that you'll forget about the probe and focus on the measurement. All SureGrip probes have an improved, more flexible strain relief for a long life.



Cleans up with soap and water

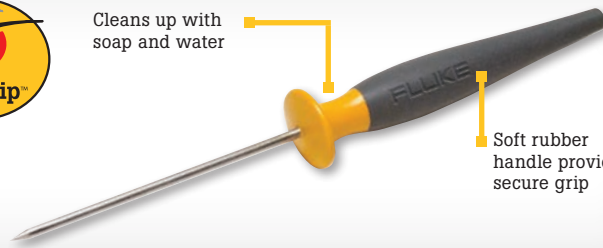

Soft rubber handle provides a secure grip

Specifications

	Bead	Bead	HVAC	Immersion	Surface	Air	Piercing	General purpose	Industrial surface
	80BK-A	80PK-1 80PJ-1	80PK-11	80PK-22	80PK-3A	80PK-24	80PK-25 80PT-25	80PK-26	80PK-27
Lowest temperature	-40 °C (-40 °F)	-40 °C (-40 °F)	-30 °C (-22 °F)	-40 °C (-40 °F)	0 °C (32 °F)	-40 °C (-40 °F)	K Type: -40 °C (-40 °F) T Type: -196 °C (-321 °F)	-40 °C (-40 °F)	-127 °C (-196 °F)
Highest temperature	260 °C (500 °F)	260 °C (500 °F)	105 °C (221 °F)	1090 °C (1994 °F)	260 °C (500 °F)	816 °C (1500 °F)	350 °C (662 °F)	816 °C (1500 °F)	600 °C (1112 °F)
Probe material	Type K wire with teflon insulation	Type K wire with teflon insulation	Hook an loop fastener	Inconel 600	Type K sensor with teflon body	Inconel	316 Stainless Steel	304 Stainless Steel	304 Stainless Steel
Probe length	1 m lead wire	1 m lead wire	19 in hook and loop cuff	21.27 cm (8.375 in)	9.525 cm (3.75 in)	21.59 cm (8.5 in)	10.16 cm (4 in)	21.57 cm (8.5 in)	20.32 cm (8 in)
Cable length	1 m (3.3 ft)	1 m (3.3 ft)	1 m (3.3 ft)	1 m (3.3 ft)	1.3 m (4 ft)	1.3 m (4 ft)	1 m (3.3 ft)	1 m (3.3 ft)	1 m (3.3 ft)
Connection	Standard banana jack	Standard banana jack	Molded thermocouple plug	Molded thermocouple plug	Molded thermocouple plug	Molded thermocouple plug	Molded thermocouple plug	Molded thermocouple plug	Molded thermocouple plug
SureGrip handle	Standard banana jack	Standard banana jack	Molded thermocouple plug	Molded thermocouple plug	Molded thermocouple plug	Molded thermocouple plug	Molded thermocouple plug	Molded thermocouple plug	Molded thermocouple plug
Key feature	Ideal for initial troubleshooting. Can be secured in place with a magnet.	Ideal for initial troubleshooting. Can be secured in place with a magnet.	Hook and loop fastener probe allows hands free temperature measurement.	For use in liquids or in gels.	Exposed junction for direct contact with flat or slightly convex surfaces.	Perforated baffle for air and non-caustic gas measurements.	Probe material safe for use in foods. Sharp tip pierces solid surfaces.	Use for general purpose air or surface measurements.	Low conductivity stainless steel minimizes thermal shunting. Extra rugged.
Thermocouple types	K	K, J	K	K	K	K	K, T	K	K
Typical use	General purpose	HVAC	Food service	Industrial	Residential	Commercial	General purpose	Industrial	Residential

The 80TK enables your meter to read temperature using mV.
For the Fluke Thermometer, 51, 52, 53, and 54 III, no adapter is necessary for thermocouple types K, J, T and E.

Temperature accessories selection guide

	113/114/115/116/117	175/177	179	233	3000 FC DMM	287/289	27-II/28-II	8945A/8946A/8903A	77 IV	83 V	87 V/88V	43B	120 Series	190 Series II	1577	1587 FC	51/52/53/54-II	561	566/568/572-2	705/707	714	715	724/725	753/754	787/789	
Contact Probes																										
80PK-1/80PK-27	1	1	2	2	2	2	2	1	1	1	2	1	1	1	1	2	•	•	•	1	•	1	•	•	1	
80PJ-1/80PJ-9																	•	•	•		•	•	•	•		
80PT-25																					•	•	•	•		
DMM Probes																										
80AK-A	•3		•	•		•	•5				•					•	•									
80BK-A	•3		•	•		•	•5				•					•	•									
80TK	•						•6	•	•	•	•	•	•	•	•	•				•	•	•	•	•	•	
80T-150UA	•	•	•	•	•	•	•	•	•	•	•	•	•	•	•	•				•	•	•	•	•	•	
Miscellaneous																										
80CK-M	1	1	2	2	2	2	2	1	1	1	2	1	1	1	1	2	•	•	•	1	•	1	•	•	1	
80CJ-M																					•	•	•	•		
80PK-EXT (4)	1	1	2	2	2	2	2	1	1	1	2	1	1	1	1	2	•	•	•	1	•	1	•	•	1	
80PJ-EXT																					•	•	•	•		
80PT-EXT																					•	•	•	•		
80PT-EXT																					•	•	•	•		

1-Requires 80TK 2-Requires 80AK 3-Fluke 116 Only 4-Also requires 80CK-M 5-28 II only 6-27 II only

Fluke temperature accessories

Turn your digital multimeter into a thermometer



FLUKE®

Other temperature accessories

80TK Thermocouple Module

- Converts type K thermocouple signals into mV output
- Connects to DMM via standard banana plugs
- Switch selectable °C or °F
- Range: -50 °C to 1000 °C (-58 °F to 1832 °F)
- Includes 80PK-1 probe



80T-150UA Universal Solid State Temperature Probe

- For measurement of air, surface and non-corrosive materials
- Measurement range: -50 °C to 150 °C (-58 °F to 302 °F)
- Output: 1 mV/°C or 1 mV/°F (switch selectable)
- Connects to DMM via standard banana plugs



80PK-8, 80PK-10, Pipe Clamp Temperature Probes

- Type K thermocouples clamp securely onto pipes for fast temperature and superheat measurements
- Durable ribbon sensors
- 1 m (39 in) lead
- Measure from -29 °C to 149 °C
- 80PK-8 for 6.4 mm to 34.9 mm (0.25 in to 1.375 in)
- 80PK-10 for 32 mm to 64 mm (1.25 in to 2.5 in)



Thermocouple Plug Kits

700TC1

- A kit of ten mini-plug connectors. One each of the following:
- Type J (black)
 - Type K (yellow)
 - Type T (blue)
 - Type E (purple)
 - Type R/S (green)
 - Type B or Cu (white)
 - Type L (J-DIN) (blue)
 - Type U (T-DIN) (brown)
 - Type C (red)
 - Type N (orange)



700TC2

- A kit of seven mini-plug connectors.
- Type J (black), two
 - Type K (yellow), two
 - Type E (purple), one
 - Type T (blue), one
 - Type R/S (green), one



80PK-18, Pipe Clamp Temperature Probe Kit

- Includes both 80PK-8 and 80PK-10 Type K clamps
- Provides full range of pipe measurement sizes
- Includes soft carrying case to conveniently keep both clamps handy for any situation



80CK-M and 80CJ-M Type K and J Male Mini-Connectors

- Isothermal screw terminal for K or J wire
- Suitable for up to 20 gauge thermocouple wire
- Color coded to industry standards (K-yellow, J-black)
- Two per package



80PJ-EXT, 80PK-EXT, 80PT-EXT Thermocouple Wire Extension Kits

- For extending and repairing type J, K or T thermocouple wires.
- Kit includes 3 m (9 ft) of thermocouple wire and 1 pair of male/female mini-connectors
 - Maximum continuous exposure temperature: 260 °C (500 °F)
 - 80PK-EXT is compatible with type K thermometers; 80PJ-EXT is designed for type J thermometers, and 80PT-EXT is designed for type T thermometers

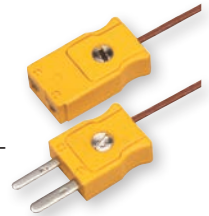

Process tools accessories

BP7240

- Li-ion rechargeable battery; nominal 7.2 volt, 4400 mA hr
- Use with 750 Series Calibrators



BP7235

- NiMH rechargeable battery; nominal 7.2 volt, 3500 mA hr
- Use in 700 and 740 Series Calibrators



700LTP-1 Low Pressure Test Pump

Hand operated pressure pump designed to generate either vacuum to -13 psi/-90 bar or pressures to 100 psi/6.9 bar. Ideal for low pressure applications requiring accurate low pressure testing.



700ILF In-line Filter

The Fluke 700ILF can be used to isolate the calibrator from incidental contact with fluids. Particularly useful with the 718 calibrator to help keep moisture or oils from contaminating the on-board pump.



700PTP-1 Pneumatic Test Pump

The Fluke 700PTP is a hand-held pressure pump designed to generate either vacuum to -11.6 psi/-0.8 bar or pressure to 600 psi/40 bar.



700HTP-2 Hydraulic Test Pump

The Fluke 700HTP is designed to generate pressures up to 10,000 psi/700 bar. Use the Fluke 700PRV adjustable relief valves to limit pressures from 94 bar (1360 psi) to 376 bar (5450 psi)



700HTH-1 Hydraulic Test Hose

The 700HTH is a 10,000 psi, 700 bar test hose that connects to a calibration unit under test from a Fluke 700HTP hydraulic test pump.



700PMP Pressure Pump

The 700PMP is a hand-operated pressure pump to provide pressures up to 150 psi/1000 kPa. Output fitting is 1/8 FNPT.



Fluke 700-IV Current Shunt

Conversion factor: 10 mV = 1 mA
Accuracy (% of input, one-year): 0.025 %
Input current: 0 mA to 55 mA
Input resistance: 250 Ω nominal
Output resistance: 10 Ω nominal
Accuracy specification applies from +18 °C and 28 °C to 50 °C
Maximum input voltage: 30 V dc



Fluke ac current clamps



i200



i200s



i400



i400s



i800



i1000s



i3000s



i2000/i3000s/i6000s Flex

i2000 Flex, i3000s Flex-24 (24 in dia), i3000s Flex-36 (36 in dia), i6000s Flex-24 (24 in dia), i6000s Flex-36 (36 in dia)

AC current clamp specifications

	i200	i200s	i400	i400s	i800	i1000s	i3000s	i2000 Flex	i3000s Flex	i6000s
AC current range	1 A to 200 A	1 A to 200 A	1 A to 400 A	0.5 A to 400 A	1 A to 800 A	0.2 A to 1000 A	1 A to 3000 A	2 A to 2000 A	3 A to 3000 A	60 A to 6000 A
Accuracy	≤ 3% + 0.5 A 48 Hz to 65 Hz	≤ 1% + 0.5 A 48 Hz to 65 Hz	2% + 0.06 A 45 Hz to 400 Hz	.5 A to 40 A, 2% + .015 A, 5 A to 400 A, 2% + .04 A, 45 Hz to 400 Hz	0.1 A to 10 A ± 3% + .01 A, 10 A to 200 A ± 2%, 200 A to 800 A ± 1%	0.2 to 10 A: 3% + 0.1 A 10 A to 100 A: 2% + 0.5 A 100 A to 1000 A: 1% + 1 A 48 Hz to 65 Hz	1 to 30 A: 2% + 0.1 A 1 to 300 A: 2% + 0.5 A 1 to 3000 A: 2% + 2 A 48 Hz to 65 Hz	± 1% of range 45 Hz to 65 Hz Ranges: 20 A, 200 A, 2000 A	± 1% of range, 45 Hz to 65 Hz Ranges: 30 A, 300 A, 3000 A	± 1% of range 45 Hz to 65 Hz
Bandwidth (-3 dB)	40 Hz to 40 kHz	40 Hz to 40 kHz	5 kHz to 20 kHz	5 Hz to 10 kHz	30 Hz to 10 kHz (typical)	5 Hz to 100 kHz	10 Hz to 100 kHz	10 Hz to 20 kHz	10 Hz to 50 kHz	10 Hz to 50 kHz, (-3 dB)
Maximum conductor diameter	20 mm (0.8 in)	20 mm (0.8 in)	32 mm (1.25 in)	32 mm (1.25 in)	54 mm (2.13 in)	54 mm (2.13 in)	64 x 100 mm (2.52 x 3.94 in)	177 mm (7 in)	177 mm (7 in) or 265 mm (10.4 in)	193 mm (7.6 in) or 289 mm (11.4 in)
Maximum conductor size	150 mm ²	150 mm ²	400 mm ²	400 mm ²	2x 240 mm ² or 1x 500 mm ²	2x 240 mm ² or 1x 500 mm ²	64 mm (2.52 in)	610 mm (24 in) circumference	610 mm or 915 mm circumference	610 mm (24 in) or 915 mm (36 in)
Output levels	1 mA/A	10 mV/A 100 mV/A	1 mA/A	10 mV/A 1 mV/A	1 mA/A	1 mV/A 10 mV/A 100 mV/A	10 mV/A 1 mV/A 0.1 mV/A	100 mV/A 10 mV/A 1 mV/A	100 mV/A 10 mV/A 1 mV/A	50 mV/A 5 mV/A 0.5 mV/A
Output cable	1.5 m shrouded banana plugs	2 m to BNC termination	1.5 m shrouded banana plugs	2.5 m to BNC termination	1.6 m shrouded banana plugs	1.6 m to BNC termination	2.1 m to BNC termination	2 m with double shrouded banana plugs	2.1 m to BNC termination	2 m to BNC, 4 mm plug adaptor supplied
Warranty	One-year	One-year	One-year	One-year	One-year	One-year	One-year	One-year	One-year	One-year
Safety rating	CAT III 600 V	CAT III 600 V	CAT III 1000 V CAT IV 600 V	CAT III 1000 V CAT IV 600 V	CAT III 600 V	CAT III 600 V	CAT III 600 V	CAT III 600 V	CAT III 600 V	CAT III 600 V

AC current clamp selection guide

	i200	i200s	i400	i400s	i800	i1000s	i3000s	i2000 Flex¹	i3000s Flex
114/116		1 A to 200 A		0.6 A to 400 A*		0.6 A to 1000 A*	1 A to 3000 A	2 A to 2000 A	3 A to 3000 A
115/117	60 A to 200 A	1 A to 200 A	60 A to 400 A	0.6 A to 400 A*	60 A to 800 A	0.6 A to 1000 A*	1 A to 3000 A	2 A to 2000 A	3 A to 3000 A
233	60 A to 200 A	1 A to 200 A	60 A to 400 A	0.6 A to 400 A*	60 A to 800 A	0.6 A to 1000 A*	1 A to 3000 A	2 A to 2000 A	3 A to 3000 A
27II	2 A to 200 A	1 A to 200 A	2 A to 400 A	1 A to 400 A*	2 A to 800 A	0.1 A to 1000 A*	1 A to 3000 A	2 A to 2000 A	3 A to 3000 A
28II	1.8 A to 200 A	1 A to 200 A	1.8 A to 400 A	1.8 A to 400 A	1.8 A to 800 A	0.2 A to 1000 A*	2 A to 3000 A	2 A to 2000 A	3 A to 3000 A
77 IV		1 A to 200 A		1 A to 400 A*		0.1 A to 1000 A*	1 A to 3000 A	2 A to 2000 A	3 A to 3000 A
175/177/179	3 A to 200 A	1 A to 200 A	3 A to 400 A	1 A to 400 A*	3 A to 800 A	0.3 A to 1000 A*	3 A to 3000 A	2 A to 2000 A	3 A to 3000 A
1577/1587 Insulation Meter	3 A to 200 A	1 A to 200 A	3 A to 400 A	3 A to 400 A*	3 A to 400 A	0.3 A to 1000 A*	3 A to 3000 A	2 A to 2000 A	3 A to 3000 A
83V/88V	2 A to 200 A	1 A to 200 A	2 A to 400 A	1 A to 400 A*	2 A to 800 A	0.1 A to 1000 A*	1 A to 3000 A	2 A to 2000 A	3 A to 3000 A
87V	2 A to 200 A	1 A to 200 A	2 A to 400 A	2 A to 400 A*	2 A to 800 A	0.2 A to 1000 A*	2 A to 3000 A	2 A to 2000 A	3 A to 3000 A
287/289	1 A to 200 A	1 A to 200 A	1 A to 400 A	0.5 A to 400 A*	1 A to 800 A	0.2 A to 1000 A*	1 A to 3000 A	2 A to 2000 A	3 A to 3000 A
43B Power Quality Analyzer		1 A to 200 A		0.35 A to 400 A		0.1 A to 1000 A	1 A to 3000 A	2 A to 2000 A	3 A to 3000 A
434/435 Power Quality Analyzer		1 A to 200 A		1.2 A to 400 A		0.3 A to 1000 A	1.2 A to 3000 A	i430Flex-TF-II	i430Flex-TF-II
120 Series ScopeMeters		1 A to 200 A		2.5 A to 400 A		0.25 A to 1000 A	2.5 A to 3000 A	2 A to 2000 A	3 A to 3000 A
190 Series ScopeMeters		1 A to 200 A		1 A to 400 A		0.1 A to 1000 A	1 A to 3000 A	2 A to 2000 A	3 A to 3000 A
8808A	1 A to 200 A	1 A to 200 A	1 A to 400 A	0.5 A to 400 A*	1 A to 800 A	0.1 A to 1000 A*	1 A to 3000 A	2 A to 2000 A*	3 A to 3000 A*
8845A/8846A	1 A to 200 A	1 A to 200 A	1 A to 400 A	1 A to 400 A*	1 A to 800 A	0.2 A to 1000 A*	1 A to 3000 A	2 A to 2000 A*	3 A to 3000 A*
787/789 Process Meters	50 A to 200 A	1 A to 200 A	50 A to 400 A	2 A to 400 A*	50 A to 440 A	0.2 A to 1000 A*	2 A to 3000 A	2 A to 2000 A	3 A to 3000 A

* Requires PM9081/001 Adapters.

¹ Three range version.

² Current and watt readings will be multiples of 10 higher or lower than actual on some ranges.

Fluke ac/dc current clamps



FLUKE®



80i-110s



i1010

**i310s, i30s and i30
Hall Effect AC/DC
Current Clamps**
Especially useful for low
current measurements
down to 30 milliamps.



i30s



i410



i310s



i30

AC/DC current clamp specifications

	80i-110s	i410	i1010	i30	i30s	i310s
DC range	0.1 A to 100 A	1 A to 400 A	1 A to 1000 A	30 mA to 30 A	30 mA to 30 A	0.1 A to 450 A
AC range	0.1 A to 70 A	1 A to 400 A	1 A to 600 A	30 mA to 20 A rms	30 mA to 20 A rms	0.1 A to 300 A
Accuracy	0.1 A to 10 A; dc to 1 kHz: ± 3% + 50 mA; up to 100 A add 15%; up to 20 kHz add 12%	3.5% + 0.5 A for dc or ac (45 to 400 Hz)	2% + 0.5 A for dc or ac (45 to 400 Hz)	± 1% of reading, ± 2 mA	± 1% of reading, ± 2 mA	30 A range: 1% + 50 mA 300 A range: 1% + 300 mA
Bandwidth [-3 dB]	100 kHz	3 kHz	10 kHz	dc to 20 kHz (-0.5 dB)	dc to 100 kHz (-0.5 dB)	dc to 20 kHz
Zero error adjustment	•	•	•	•	•	•
Maximum conductor diameter	11.8 mm (0.46 in)	30 mm (1.18 in)	30 mm (1.18 in)	19 mm (0.75 in)	19 mm (0.75 in)	19 mm (0.75 in)
Maximum conductor size	35 mm ²	1x 400 mm ² or 2x 240 mm ²	1x 400 mm ² or 2x 240 mm ²	120 mm ²	120 mm ²	120 mm ²
Output levels	10 mV/A, 100 mV/A	1 mV/A	1 mV/A	100 mV/A	100 mV/A	1 mV/A, 10 mV/A
Output cable	1.6 meter with BNC termination	1.2 meter with shrouded banana plugs	1.2 meter with shrouded banana plugs	1.5 meter with shrouded dual banana plugs	2 meter with BNC termination	2 meters with BNC termination and a BNC to safety shrouded banana adapter
Battery life	40 hours	60 hours	60 hours	30 hours	30 hours	30 hours
Warranty	One-year	One-year	One-year	One-year	One-year	One-year
Safety	CAT II 600 V; CAT III 300 V	CAT III 600 V	CAT III 600 V	CAT III 300 V	CAT III 300 V	CAT III 300 V

AC/DC current clamp selection guide

	80i-110s	i410	i1010	i30	i30s	i310s
114/115/116/117	0.1 A to 100 A dc/ 0.1 A to 70 A ac*	1.4 A to 400 A dc/ 6 A to 400 A ac	1.4 A to 1000 A dc/ 6 A to 600 A ac	30 mA to 30 A dc/ 60 mA to 20 A ac	30 mA to 30 A dc/ 60 mA to 20 A ac	0.1 A to 450 A dc/ 0.6 A to 300 A ac
233	0.1 A to 100 A dc/ 0.1 A to 70 A ac*	1.4 A to 400 A dc/ 6 A to 400 A ac	1.4 A to 1000 A dc/ 6 A to 600 A ac	30 mA to 30 A dc/ 60 mA to 20 A ac	30 mA to 30 A dc/ 60 mA to 20 A ac	0.1 A to 450 A dc/ 0.6 A to 300 A ac
27II	0.1 A to 100 A dc/ 0.1 A to 70 A ac*	1 A to 400 A dc/ 1 A to 400 A ac	1 A to 1000 A dc/ 1 A to 600 A ac	30 mA to 30 A dc/ 30 mA to 20 A ac	30 mA to 30 A dc/ 30 mA to 20 A ac	0.1 A to 450 A dc/ 0.1 A to 300 A ac
28II	0.1 A to 100 A dc/ 0.2 A to 70 A ac*	1 A to 400 A dc/ 6 A to 400 A ac	1 A to 1000 A dc/ 6 A to 600 A ac	30 mA to 30 A dc/ 60 mA to 20 A ac	30 mA to 30 A dc/ 60 mA to 20 A ac	0.1 A to 450 A dc/ 2 A to 300 A ac
77-IV	0.1 A to 100 A dc/ 0.1 A to 70 A ac*	1 A to 400 A dc/ 5 A to 400 A ac	1 A to 1000 A dc/ 5 A to 600 A ac	30 mA to 30 A dc/ 40 mA to 20 A ac	30 mA to 30 A dc/ 40 mA to 20 A ac	0.1 A to 450 A dc/ 0.4 A to 300 A ac
175/177/179	0.11 A to 100 A dc/ 0.3 A to 70 A ac*	1.6 A to 400 A dc/ 30 A to 400 A ac	1.6 A to 1000 A dc/ 30 A to 600 A ac	30 mA to 30 A dc/ 300 mA to 20 A ac	30 mA to 30 A dc/ 300 mA to 20 A ac	0.1 A to 450 A dc/ 3 A to 300 A ac
1577/1587 FC Insulation Meter	0.1 A to 100 A dc/ 0.3 A to 70 A ac*	1.2 A to 400 A dc/ 30 A to 400 A ac	1.2 A to 1000 A dc/ 30 A to 600 A ac	30 mA to 30 A dc/ 300 mA to 20 A ac	30 mA to 30 A dc/ 300 mA to 20 A ac	0.1 A to 450 A dc/ 3 A to 300 A ac
83V/88V	0.1 A to 100 A dc/ 0.1 A to 70 A ac*	1 A to 400 A dc/ 1 A to 400 A ac	1 A to 1000 A dc/ 1 A to 600 A ac	30 mA to 30 A dc/ 30 mA to 20 A ac	30 mA to 30 A dc/ 30 mA to 20 A ac	0.1 A to 450 A dc/ 0.1 A to 300 A ac
87V	0.1 A to 100 A dc/ 0.2 A to 70 A ac*	1 A to 400 A dc/ 20 A to 400 A ac	1 A to 1000 A dc/ 20 A to 600 A ac	30 mA to 30 A dc/ 200 mA to 20 A ac	30 mA to 30 A dc/ 200 mA to 20 A ac	0.1 A to 450 A dc/ 2 A to 300 A ac
287/289	0.1 A to 100 A dc/ 0.1 A to 70 A ac*	1 A to 400 A dc/ 1 A to 400 A ac	1 A to 1000 A dc/ 1 A to 600 A ac	30 mA to 30 A dc/ 30 mA to 20 A ac	30 mA to 30 A dc/ 30 mA to 20 A ac	0.1 A to 450 A dc/ 0.1 A to 300 A ac
123/124 ScopeMeters	0.1 A to 100 A dc/ 0.25 A to 70 A ac	1 A to 400 A dc/ 25 A to 400 A ac**	1 A to 1000 A dc/ 25 A to 600 A ac**	30 mA to 30 A dc/ 250 mA to 20 A ac	30 mA to 30 A dc/ 250 mA to 20 A ac	0.1 A to 450 A dc/ 2.5 A to 300 A ac
190 Series ScopeMeters	0.1 A to 100 A dc/ 0.1 A to 70 A ac	1 A to 400 A dc/ 5 A to 400 A ac**	1 A to 1000 A dc/ 5 A to 600 A ac**	30 mA to 30 A dc/ 50 mA to 20 A ac**	30 mA to 30 A dc/ 50 mA to 20 A ac	0.1 A to 450 A dc/ 0.5 A to 300 A ac
8808A	0.1 A to 100 A dc/ 0.1 A to 70 A ac*	1 A to 400 A dc/ 2 A to 400 A ac	1 A to 1000 A dc/ 2 A to 600 A ac	30 mA to 30 A dc/ 30 mA to 20 A ac	30 mA to 30 A dc/ 30 mA to 20 A ac	0.1 A to 450 A dc/ 0.2 A to 300 A ac
8845A/8846A	0.1 A to 100 A dc/ 0.1 A to 70 A ac*	1 A to 400 A dc/ 1 A to 400 A ac	1 A to 1000 A dc/ 1 A to 600 A ac	30 mA to 30 A dc/ 30 mA to 20 A ac	30 mA to 30 A dc/ 30 mA to 20 A ac	0.1 A to 450 A dc/ 0.1 A to 300 A ac
705/707	0.1 A to 100 A dc, no ac*	4 A to 400 A dc, no ac	4 A to 1000 A dc, No ac	40 mA to 30 A dc, no ac	40 mA to 30 A dc, no ac	0.4 A to 450 A dc, no ac
715	0.1 A to 100 A dc, no ac*	4 A to 400 A dc, no ac	4 A to 1000 A dc, No ac	40 mA to 30 A dc, no ac	40 mA to 30 A dc, no ac	0.1 A to 450 A dc, no ac
787/789 Process Meters	0.1 A to 100 A dc/ 0.2 A to 70 A ac*	1 A to 400 A dc/ 20 A to 400 A ac	1 A to 1000 A dc/ 20 A to 600 A ac	30 mA to 30 A dc/ 200 mA to 20 A ac	3 mA to 30 A dc/ 200 mA to 20 A ac	0.1 A to 450 A dc/ 2 A to 300 A ac

* Requires PM9081 Adapter

** Requires PM9082/001 Adapter

Fluke lights and hangers

Free your hands and shed light on the contact point



LVD1 Volt Light

- Exclusive dual-sensitivity
- Detects voltages from 40 V ac to 300 V ac
- Voltage detector glows blue at 50 Hz or 60 Hz or 2.5 cm to 38 cm (1 in to 5 in) away from source
- Ultra-bright white LED with 100,000 hour bulb life
- AAA battery included



LVD2 Volt Light

- Non-contact ac voltage detector and bright white LED flashlight
- Detects voltage from 90 V to 600 V ac from one to 12.7 cm (5 inches) away
- CAT IV rated, one-year warranty



L205 Mini Hat Light

Rugged, high-intensity Xenon worklight.

- Attaches to a baseball cap
- Includes a hat clip
- Includes two AAA batteries
- Waterproof



L206 Deluxe LED Hat Light

(hard hat not included)

Attach it to a hard hat, a baseball cap, or even a panel door.

- Three super bright white LEDs never burn out
- Special hard-hat attachment included
- 40-hour battery life
- Includes three AAA batteries

TPAK ToolPak™ Magnetic Meter Hanger

- Free both hands to make measurements
- Hang your meter from metallic surfaces like panels and pipes
- Kit includes universal hanger clips (two), hook and loop straps (two lengths), adapter and strong magnet
- Attaches to back of many Fluke meters, including 110, 170, 180, 280 Series, 87V and 83V DMMs, 724, 725 and 789 Process Calibrators, 70 Series III DMMs, 1503, 1507, 1577 and 1587 Insulation Multimeters and 50 Series II Digital Thermometers



LeadWrap Test Lead Fasteners

- Keep your favorite leads together
- Hook and loop fasteners
- Three per package



L215 SureGrip™ Kit with Probe Light and Probe Extenders

- L200 probe light
- TP220 SureGrip test probes
- TL224 SureGrip test leads
- TP280 test probe extenders
- Soft foldable pouch, keeps the entire set together



L210 Probe Light and Probe Extenders

- 20.3 cm (8 in) probe extenders fit modular test probes
- Probe extender complies with EN 61010-031
- Bright white LED illuminates contact area
- Probe light fits on extender or test probe

Specialty accessories and software

Get more out of your test tool



FLUKE®

Stray voltage

SV225

- Eliminates stray voltage due to capacitance between wires in electrical installations
- Compatible with all instruments and test leads that accept standard 4 mm shrouded banana connectors



Pressure and vacuum

PV350 Pressure Vacuum Module

- Digital pressure and vacuum measurements in a single module
- Measures HVAC/R, hydraulic and pneumatic pressures to 350 psig/2413 kPa (usable to 500 psig)
- Measures to 760 mmHg (29.9 in Hg) vacuum (not intended for measuring microns of vacuum)
- Compatible with most digital multimeters



Fluke Connect®

ir3000 FC Connector

- Get all the benefits of the Fluke Connect app, and be on the same page, even while in different places
- Wirelessly share measurements with your team anywhere, anytime
- Connect the Fluke 289/287 True-rms Logging Multimeter and the 789 ProcessMeter with the ir3000 FC Connector



Fluke Connect® Wireless SD Card

Wirelessly enable your Fluke TiX1000, TiX660, or TiX640 infrared camera with the Fluke Connect wireless SD card. Instantly upload, share and analyze data with anyone on your team. The Fluke Connect WiFi SD Card is included with compatible models, but is shipped separately due to country restrictions.



FlukeView® Forms

Harness the power of the data logging function on your Fluke Digital Multimeter, Thermometer or ProcessMeter. Log live readings while connected to a PC, or leave your Fluke 289, 789 or 54-II in place to capture up to 1,000 readings for download to a PC.



Choose the model that's right for you:

- FVF-SC2:** Includes software and cable used with 280 Series DMMs and 789 ProcessMeters, and the 1550 and C/1555 Insulation Tester
- FVF-SC3:** Includes software and cable used with 45 Bench Meters
- FVF-SC4:** Includes software and cable used with 8845A and 8846A Multimeters

Fuse selection guide

Replacement fuses for Fluke DMMs are available from your distributor.

Model	Fuse Requirements
21-III/75-III/73-III	P/N 871173 630 mA 250 V fuse P/N 803293 11 A 1000 V fuse
27 (S/N < 7247001)	P/N 871173 630 mA 250 V fuse P/N 871202 3 A 600 V fuse P/N 892583 15 A 600 V fuse
27 (S/N > 7247001)	P/N 943121 440 mA 1000 V fuse P/N 803293 11 A 1000 V fuse
83/85/87 (S/N > 6565000)	P/N 943121 440 mA 1000 V fuse P/N 803293 11 A 1000 V fuse
83-III/85-III/87-III 87-IV/89-IV/187/189/287/289/ 77-III/79-III/23-III/26-III/175/177/179/77-IV/27-II/28-II	P/N 943121 440 mA 1000 V fuse P/N 803293 11 A 1000 V fuse
111/112/115/117/233	P/N 803293 11 A 1000 V fuse
1577/1587	P/N 943121 440 mA 1000 V fuse
1503/1507	P/N 2279339 315 mA 1000 V fuse
787/789	P/N 943121 440 mA 1000 V fuse (Qty 2)

Selection Guide	110/111/112	114/115/116/117	27 II/28 II/27	175/177	179	80 Series III/83V	87/89 IV	87V	233	287/289/187/189	43B	120 Series	190 Series	51/52/53/54 II	705/707	715	725/726	741/743	744	787/789	1587 FC	1577	
TPAK	•	•	•	•	•	•	•	•	•	•	•	•	•	•	•	•	•	•	•	•	•	•	•
PV350 (pressure)	•	•	•	•	•	•	•	•	•	•	•	•	•	•	•	•	•	•	•	•	•	•	•
FOM (fiber optic)	•	•	•	•	•	•	•	•	•	•	•	•	•	•	•	•	•	•	•	•	•	•	•

Model	Instrument compatibility	Cable
FVF-BASIC	Fluke 280 Series, 789, 1550B, 1653, 180 Series	USB/IR
FVF-SC2	Fluke 280 Series, 789, 1550B, 1653, 180 Series	USB/IR
FVF-SC4	Fluke 8808A, 8845A, 8846A, 45*	USB/Serial
IR189USB	USB cable for Fluke-18X, 28X DMMs	USB/IR

FlukeView® Forms Basic

An abridged version of FlukeView Forms.

- Available for use with 280 Series DMMs and 789 ProcessMeters, only
- Upgrade to the full FlukeView Forms with FVF-UG
- Compatible with the 280 and 789 series only

Choose the model that's right for you:

- FVF-Basic:** FlukeView Forms Basic transfers data from Fluke test tool to a PC. Displays readings in table or graphical format
- FVF-SC2, -SC4:** FlukeView Forms Full provides Basic software functions plus customizable documents and templates
- FVF-UG:** FlukeView Forms Upgrade, compatible with all forms of FlukeView Forms (Basic and Full)

Fluke: Where safety is built in

As distribution systems and loads become more complex, the possibilities of transient overvoltages increase. Motors, capacitors and power conversion equipment such as variable speed drives can be prime generators of voltage spikes. Lightning strikes on outdoor transmission lines also cause extremely hazardous high-energy transients. If you're taking measurements on electrical systems, these transients are "invisible" and largely unavoidable hazards. They occur regularly on low-voltage power circuits, and can reach peak values in the many thousands of volts. To protect you against transients, safety must be built into your test equipment.

Who develops safety standards?

The IEC (International Electrotechnical Commission) develops international general standards for safety of electrical equipment for measurement, control and laboratory use. IEC61010-1 is used as the basis for the following national standards:

- US ANSI/ISA-S82.01-94
- Canada CAN C22.2 No.1010.1-92
- Europe EN61010-1:2001

Overvoltage installation categories

IEC61010-1 specifies categories of overvoltage based on the distance the piece of equipment is from the power source (see Figure 1 and Table 1) and the natural damping of transient energy that occurs in an electrical distribution system. Higher categories are closer to the power source and require more protection. Within each

installation category there are voltage classifications. It is the combination of installation category and voltage classification which determines the maximum transient withstand capability of the instrument.

IEC 61010 test procedures take into account three main criteria: steady-state voltage, peak impulse transient voltage and source impedance. These three criteria together will tell you a multimeter's true voltage withstand value.

Within a category, a higher working voltage (steady-state voltage) is associated with a higher transient, as would be expected. For example, a CAT III 600 V meter is tested with 6000 V transients while a CAT III 1000 V meter is tested with 8000 V transients. So far, so good. What is not as obvious is the difference between the 6000 V transient for CAT III 600 V and the 6000 V transient for CAT II 1000 V. They are not the same. This is where the source impedance comes in. Ohm's Law ($Amps = Volts/Ohms$) tells us that the 2Ω test source for CAT III has six times the current of the 12Ω test source for CAT II. The CAT III 600 V meter clearly offers superior transient protection compared to the CAT II 1000 V meter, even though its so-called "voltage rating" could be perceived as being lower.

See Table 2. Independent testing is the key to safety compliance. How can you tell if you're getting a genuine CAT III or CAT II meter? Unfortunately it's not always that easy. It is possible for a manufacturer to self-certify that

its meter is CAT II or CAT III without any independent verification. The IEC (International Electrotechnical Commission) develops and proposes standards, but it is not responsible for enforcing the standards. Look for the symbol and listing number of an independent testing lab such as UL, CSA, VDE, TÜV or other recognized approval agency.

These symbols can only be used if the product successfully completed testing to the agency's standard, which is based on national and international standards. UL 3111, for example, is based on EN61010-1. In an imperfect world, this is the closest you can come to ensuring that the meter you choose was actually tested for safety.

Safety is everyone's responsibility but ultimately it is in your hands.

No tool by itself can guarantee your safety when working with electricity. It's the combination of the right tools and safe work practices that gives you maximum protection. Here are a few tips to help you in your work:

- Make sure you always comply with (local) regulations.
- Work on de-energized circuits whenever possible. Use proper lock-out/tag-out procedures.

If these procedures are not in place or enforced, assume that the circuit is live.

- Use protective gear when working on live circuits

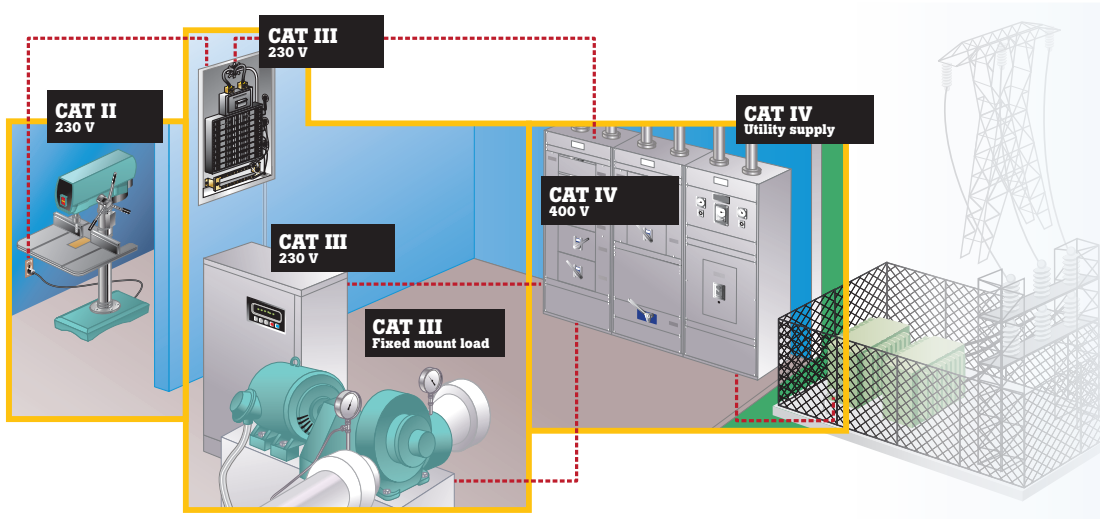

Figure 1. Understanding categories: location

Measurement category	In brief	Examples
CAT IV	Three-phase at utility connection, any outdoor mains conductors. Expected short circuit current above 50 kA.	<ul style="list-style-type: none"> Refers to the “origin of installation,” i.e., where low-voltage connection is made to utility power Electricity meters, primary overcurrent protection equipment Outside and service entrance, service drop from pole to building, run between meter and panel Overhead line to detached building, underground line to well pump
CAT III	Three-phase distribution, including single-phase commercial lighting. Expected short circuit current above 10 kA up to 50 kA.	<ul style="list-style-type: none"> Equipment in fixed installations, such as switchgear and polyphase motors Bus and feeder in industrial plants Feeders and short branch circuits, distribution panel devices Lighting systems in larger buildings Appliance outlets with short connections to service entrance
CAT II	Single and three-phase receptacle connected loads. Expected short circuit current up to 10 kA.	<ul style="list-style-type: none"> Appliance, portable tools, and other household and similar loads Outlet and long branch circuits

Table 1. Measurement categories. IEC/EN 61010 applies to low-voltage (< 1000 V) test equipment

- Use insulated tools
- Wear safety glasses and a face shield
- Wear insulated gloves, remove watches or jewelry
- Use hearing protection
- Stand on an insulated mat
- Wear flame resistant clothing, not ordinary work clothes

This is a minimum suggested list. More protective gear may be required, depending on the level of electrical hazard and regional regulations.

Select the right test tool:

- ✓ Choose a test tool rated to the highest category and voltage for which it could possibly be used (most often 600 or 1000 volt CAT III and/or 600 volt CAT IV).
- ✓ Look for the category and voltage marking near the recessed input connectors of your test tool and a “double insulated” symbol on the back.



- ✓ Verify your test tool has been tested and certified by two or more independent testing laboratories, such as UL in the United States and VDE or TÜV in Europe by looking for the symbols of these agencies on (the back of) your test tool.

- ✓ Make sure that the test tool is made of a high-quality, durable non-conductive material.
- ✓ Check the manual to verify that the ohms, continuity and capacitance circuits are protected to the same level as the voltage test circuit, to reduce hazards when the test tool is used incorrectly in ohms, continuity or capacitance mode (if applicable).
- ✓ Verify that the test tool has internal protection to prevent instrument damage when voltage is incorrectly applied to an amperage measurement function (if applicable).
- ✓ Make sure that the amperage and voltage of your test tool's fuses meets specifications. Fuse voltage must be as high or higher than the test tool's voltage rating.



- ✓ Be sure to use test leads that have:
 - Shrouded connectors
 - Finger guards and a non-slip surface
 - Category ratings that equal or exceed those of the test tool
 - Double insulation (look for the symbol)
 - A minimum of exposed metal on the probe tips

Inspect and test your test tool:

- ✓ Check for a broken case, worn test leads or a faded display.
- ✓ Make sure the batteries still deliver sufficient power to get reliable readings. Many test tools have a low battery indicator on the display.
- ✓ Check the test leads resistance for internal breaks while moving the leads around (good leads measure 0.1 to 0.3 ohm).
- ✓ Use the meter's own test capability to ensure that the fuses are in place and working right (see manual for details).

Apply the appropriate working practices when measuring on live circuits:

- ✓ Hook on the ground clip first, then make contact with the hot lead. Remove the hot lead first, the ground lead last.
- ✓ Use the three-point test method, especially when checking to see if a circuit is dead. First test a known live circuit. If you work in environments where there isn't a reliable circuit, consider using a portable voltage source like a Proving Unit for this step. Second, test the target circuit. Third, test the live circuit again. This verifies that your test tool worked properly before and after the measurement.
- ✓ Hang or rest the test tool if possible. Try to avoid holding it in your hands, to minimize personal exposure to the effects of transients.
- ✓ Use the old electrician's trick of keeping one hand in your pocket. This lessens the change of a closed circuit across your chest and through your heart.

Fuse and warranty info

Product Warranty

Each Fluke product is warranted to be free from defects in material and workmanship under normal use and service, for the warranty period listed unless local law requires a longer period. The warranty period is listed in the ordering information section of the product specification and begins on the date of shipment. This warranty extends only to the original buyer or end-user customer of a Fluke authorized reseller, and does not apply to fuses, disposable batteries or to any product which, in Fluke's opinion, has been misused, altered, neglected or damaged by accident or abnormal conditions of operation or handling. Fluke warrants that software will operate substantially in accordance with its functional specifications for 90 days and that it has been properly recorded on non-defective media. Fluke does not warrant that software will be error free or operate without interruption.

Lifetime Warranty

Each Fluke 20, 70, 80, 170, 180 and 280 Series DMM purchased after October 1, 1996 will be free from defects in material and workmanship for its lifetime. This warranty does not cover fuses, disposable batteries and damage from accident, neglect, contamination, misuse or abnormal conditions of operation or handling, including overvoltage failures caused by use outside the DMM's specified rating, or normal wear and tear of mechanical components. This warranty covers the original purchaser only and is not transferable. For ten years from the date of purchase, this warranty also covers the LCD. Thereafter, for the lifetime of the DMM, Fluke will replace the LCD for a fee based on then current component acquisition costs.

To establish original ownership and prove date of purchase, please complete and return the registration card accompanying the product.

Service

Fluke will, at its discretion, repair at no charge, replace or refund the purchase price of a defective product purchased through a Fluke authorized sales outlet and at the applicable international price. Fluke reserves the right to charge for importation costs of repair/replacement parts if product purchased in one country is sent for repair elsewhere. Send

defective product with a description of the problem to the nearest Fluke Authorized Service Center, postage and insurance prepaid. Fluke will pay return transportation for product repaired or replaced in warranty. Before making any non-warranty repair, Fluke will estimate cost and obtain authorization, then invoice you for repair and return transportation.

This warranty is your only remedy. No other warranties, such as fitness for a particular purpose, are expressed or implied. Fluke is not liable for any special, indirect, incidental or consequential damages or losses, including loss of data, arising from any cause or theory. Authorized resellers are not authorized to extend any different warranty on Fluke's behalf.

Since some states do not allow the exclusion or limitation of an implied warranty or of incidental or consequential damages, this limitation of liability may not apply to you.



Fuse replacement information

A	V	IR	Size in mm	Part nr qty 1
63mA (slow)	250V		6.35x32	163030
125mA (slow)	250V		6.35x32	166488
250mA (slow)	250V		6.35x32	166306
315 mA	1000V	10kA	6.35x32	2279339
440mA	1000V	10kA	10.3x34.9	943121
500mA	250V	1500A	5x20	838151
630mA	250V	1500A	5x20	740670
1A	600V	10kA	10.3x34.9	830828
1A	500V	50kA	6.35x 32	2530449
1.25A	600V		6.35x32	2040349
3.15A	500V		6.35x32	2030852
11A	1000V	17kA	Replaced by 11A, 1000V, 20kA fuse; 803293	
11A	1000V	20kA	10.3x38.1	803293
15A	600V	100kA	10.3x38.1	892583
20A	600V	20A 600V Replaced by 15A, 600V, 100kA fuse; part nr. 892583		

See the back of your Fluke test tool or user manual for the fuses installed. For manuals check the Fluke website in the product section. For Fuse Replacement Guide check the Fluke website in the service section.

Let Fluke after sales service help you further

Did you know that the Fluke after sales service team can offer you much more than just repairing and calibrating your instrument when it is needed? Across our whole Fluke European service organization we have a vast range of capabilities, which can be utilized via your local service centre. Behind the scenes Fluke draws on the expertise of over 150 service staff that are focused on offering only the best and most comprehensive after sales service.

Fluke service centres handle a wide range of equipment.

As part of Fluke's continuing focus on improving our service to our customer we now offer a comprehensive range of repairs and calibrations on a vast range of equipment.

Fluke manufactures equipments such as:

Fluke brands	Instrument types
Fluke	Digital Multimeters
Hart Scientific	Electrical Standards
Fluke Networks	Biomedical Equipment
Fluke Biomedical	Data Loggers
Raytek	Thermal Imagers
Reliable Power Meters	Thermometers
Robin	Pressure
LEM Instruments	Function Generators
BEHA	Oscilloscopes
Norma	Installation Testers
Wavetek/Datron	PAT Testers
Metron	Clamp Meters
DHI	Power Analyzers
Comark	EX meters
Amprobe	Plus many more



So why should you use Fluke service?

- Original manufacturers' parts used
- All instruments reviewed for latest updates
- Repair warranty that covers whole unit
- In depth product knowledge
- Accredited calibrations available
- Traceable calibrations available on all products
- Full check of unit during verification cycle
- Full safety test on mains powered units

What other instruments can we help you with?

We also offer a range of calibrations and repairs on other manufacturer's equipment upon request.

Manufacturers such as:

- Tektronix
- Agilent
- Bruel & Kjaer
- Philips
- Megger
- Seaward
- Kewtech
- Lecroy
- Hioki
- Yokogawa
- Druck
- Iwatzu
- plus many more ...

What other value added services do we offer?

- Gold Support for Fluke Networks
- Gold CarePlans for calibration products
- A full range of maintenance contracts
- Extended warranty programs
- Instrument upgrades
- Option retrofits
- Asset management
- Calibration reminders

What services do we offer you?

- 5 day repairs on all current products
- 5 days or less on all calibrations (excl.repairs)
- 3 days for all Gold CarePlan calibrations
- 1-2 days on all Networks Gold calibration
- Pick up services where available

On-Line booking in system

Why not use our On-Line booking in system where you can book your unit in, get pricing and receive a RMA number for a smooth return.



Prevent downtime with Fluke

How much does unexpected downtime cost your facility per minute, hour or day? Fluke tools can play a pivotal role in helping you identify equipment issues before they become problems and avoid costly delays.

By measuring key indicators on critical equipment and sharing that data immediately, you can discover impending failures and schedule maintenance. With over 40 connected wireless tools, Fluke Connect® lets you identify and diagnose problems quickly and confidently, while sharing your data when you want and with whom you want.



438-II



279 FC



TiX500



Organize your measurements by asset on location with the AutoRecord™ Plus feature in the Fluke Connect Assets software.

Fluke tools engineered for safety

Fluke tools are rigorously tested and have the highest safety category ratings to match your different work environments. Whether you work with electrical systems, motors and machinery or any of the many other professional jobs, our tools are engineered for safety. From digital multimeters to infrared cameras and IR windows to tracking measurements remotely, you can trust Fluke. Our new Fluke Connect® app and wireless enabled tools allow you to capture measurements up to 20 meters away from energized lines and moving machinery. You can safely troubleshoot issues and share the results with your team, anywhere, any time.



Ti450

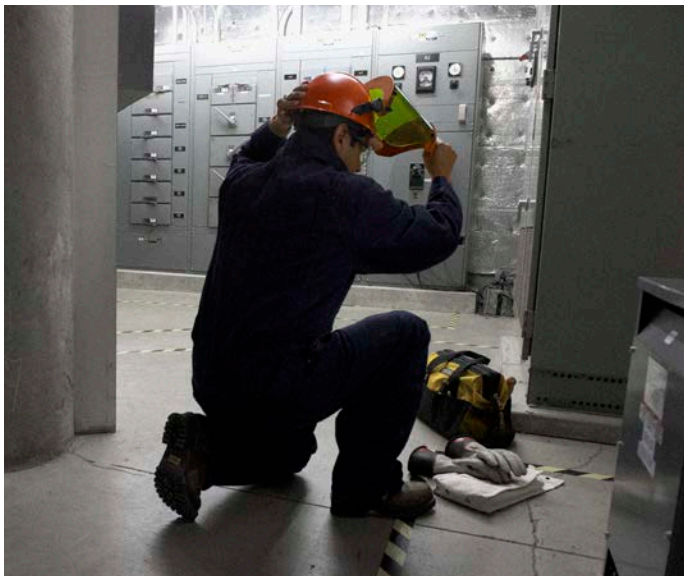



FLUKE®

Electrical, Multifunction, and mA Loop Calibration

Data Acquisition

Pressure Calibration

Temperature Calibration

Software/Accessories

Pressure Applications

Temperature Applications

PROCESS CALIBRATION TOOLS CATALOG



Process Calibration Tools

From Fluke and Fluke Calibration

Working in a process environment such as pharmaceutical, refining or other industrial area can be challenging. Whether you're working at a bench, out in the plant, or in the field, you need accurate tools that you can count on.

Finding the right tools for the specific challenges you face every day is important, so we've provided an "at-a-glance" guide to the wide range of multifunction, mA loop, pressure and temperature calibrators that we carry.



Electrical and multifunction calibration

Fluke offers a broad range of field and bench calibrators to source, simulate, and measure pressure, temperature, and electrical signals to help you verify and adjust your test equipment or almost any process instrument.



mA loop calibration

Loop calibrators are essential tools for working with 4-20 mA current loops. Fluke loop calibrators provide mA sourcing, simulation and measurement, readouts in both mA and % of span, 24 V loop supply, simple operation and accuracy you can count on.



Pressure calibration

Instrumentation is found in virtually every process plant. Periodic calibration of these instruments is required to keep plants operating efficiently and safely. Fluke provides a wide selection of field and bench calibration tools to help you quickly and reliably calibrate your pressure instrumentation.



Temperature calibration

Temperature calibration refers to the calibration of any device used in a system that measures temperature—from sensors to transmitters to displays. Fluke offers bench and field solutions to ensure process temperature accuracy of not only the system's electronic temperature signals, but also the very temperature sensors that initiate those signals.

Process Calibration Tools

Electrical, Multifunction, and mA Loop Calibration

4

Multifunction calibrators5
 mA loop calibrators.....7

Data Acquisition

9

Data acquisition systems9

Pressure Calibration

10

Digital pressure calibrators 11
 Pressure comparators and master gauges 12
 Manual pressure calibrators 13
 Reference pressure calibrator 14
 Bench deadweight testers 14

Temperature Calibration

16

Handheld temperature calibrators.....17
 Pressure comparators and master gauges.....17
 Field temperature sources18
 Infrared temperature sources19
 Thermometer standards.....20
 Ambient conditions monitor.....20
 Precision PRTs21
 Thermistors21

Software/Accessories

22

Software 22
 Temperature calibration software..... 23
 Accessories..... 23

Pressure Applications

24

Calibrating a HART smart pressure transmitter 26
 Pressure transmitter calibration at the bench..... 28
 Pressure switch testing - manual..... 30
 Pressure switch testing - documented 32

Gas custody transfer flow computer calibration..... 34
 Verifying process gauges, analog and digital..... 36
 Calibrating at the bench with a deadweight tester 38
 Calibrating at the bench with a pressure comparator 40
 Use and selection of hand pumps and pressure test gauges for field pressure testing..... 42

Temperature Applications

42

Calibrating and testing RTD Sensors 46
 Calibrating and testing thermocouple sensors 48
 Simulating thermocouples and RTDs for calibration and testing... 50
 Using a precision thermometer for single point process temperature verification 52
 Temperature switch and controller testing in the field..... 54
 Temperature switch and controller testing at the bench..... 56
 Calibrating with a micro-bath..... 58
 Infrared thermometer test and calibration 60
 Loop calibration with a temperature transmitter at the bench..... 62

**Electrical,
Multifunction,
and mA Loop
Calibration**

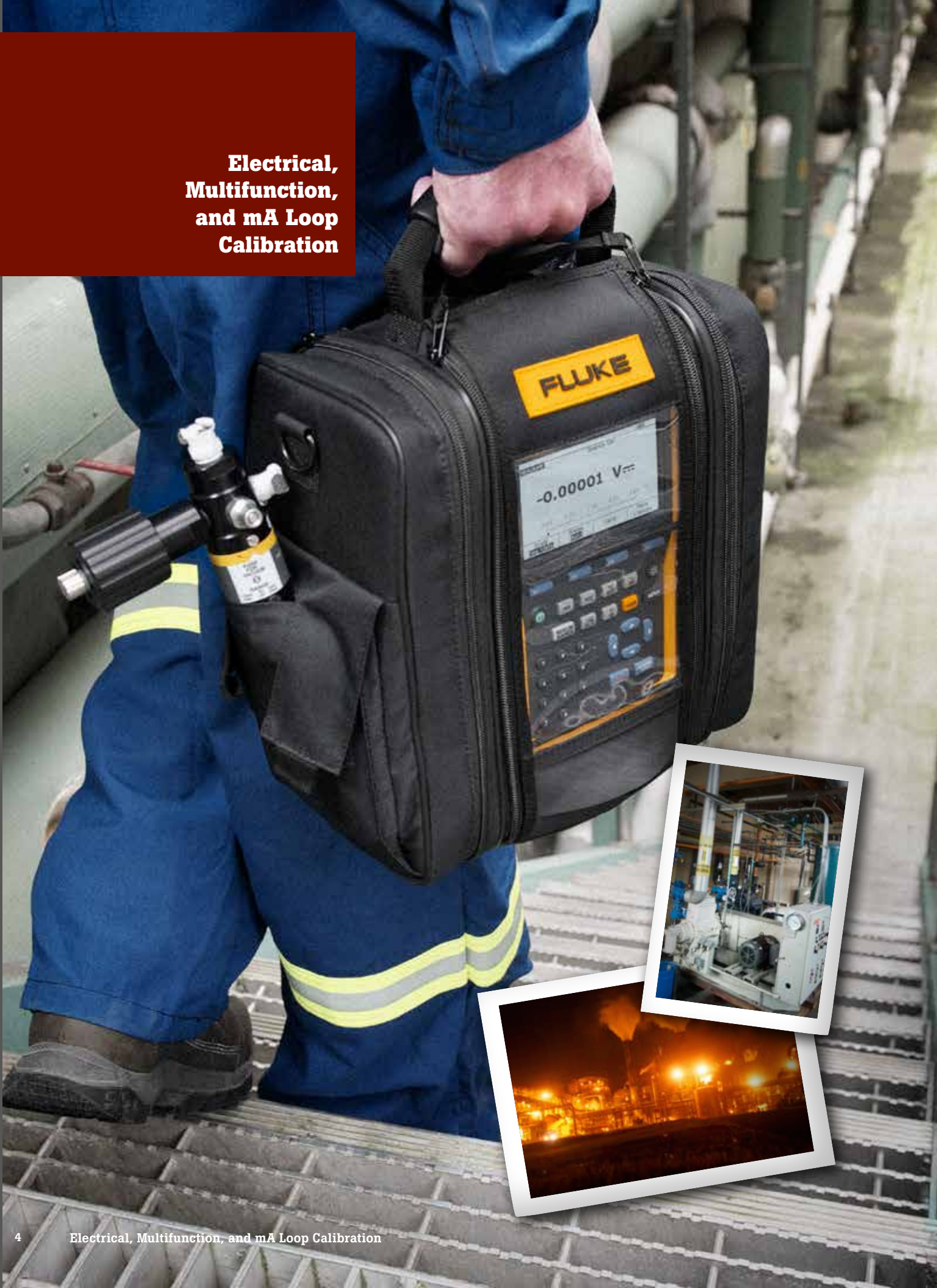



753



754



7526A

Multifunction Calibrators

These field and bench calibrators source, simulate, and measure pressure, temperature, and electrical signals with exceptional precision.

753 Documenting Process Calibrator

Rugged handheld tool for sourcing, simulating and measuring pressure, temperature, and electrical signals.

- Measure volts, mA, RTDs, thermocouples, frequency, and ohms to test sensors, transmitters and other instruments
- Source/simulate volts, mA, thermocouples, RTDs, frequency, ohms, and pressure to calibrate transmitters
- Power transmitters during test using loop supply with simultaneous mA measurement
- Download procedures and upload calibration results from field calibrations
- NIST traceable calibration

754 Documenting Process Calibrator with HART

Rugged, reliable tool for calibrating, maintaining, and troubleshooting HART and other instrumentation.

- Measure volts, mA, RTDs, thermocouples, frequency, and ohms to test sensors, transmitters and other instruments
- Source/simulate volts, mA, thermocouples, RTDs, frequency, ohms, and pressure to calibrate transmitters
- Supports popular models of HART transmitters, with more device-specific command support than any other HART field calibrator
- Download procedures and upload calibration results from field calibrations
- NIST traceable calibration



7526A Precision Process Calibrator

Best balance of economy and accuracy for calibration of temperature and pressure process measurement instrumentation.

- Sources and measures dc voltage, current, resistance, RTDs and thermocouples
- Measures pressure using Fluke 700/525A-P pressure modules
- Includes 24 V dc loop power supply, automated switch-test function and measures 4 mA to 20 mA
- NIST traceable calibration



726



725



725Ex



8808A



8845A/8846A

726 Precision Multifunction Process Calibrator

Designed specifically for the process industry with broad workload coverage, calibration power and unsurpassed accuracy. Includes all the features and functions of the 725 below plus:

- Enhanced accuracy
- Pulse count sourcing and pulse measurement totalizing
- Pressure switch test
- Error % calculation
- NIST traceable calibration

725 Multifunction Process Calibrator

A powerful and easy-to-use field calibrator to test and calibrate almost any process parameter.

- Measure volts, mA, RTDs, thermocouples, frequency, and ohms to test sensors and transmitters
- Source/simulate volts, mA, thermocouples, RTDs, frequency, ohms, and pressure to calibrate transmitters
- Measure/source pressure using any of 29 Fluke 700Pxx Pressure Modules
- Source mA with simultaneous pressure measurement to conduct valve and I/P tests
- NIST traceable calibration

725EX IS Multifunction Process Calibrator

Easy-to-use, intrinsically safe field calibrator can calibrate almost any process instrument needing service where explosive gasses may be present.

- ATEX II 1 G Ex ia IIB 171 °C KEMA 04ATEX 1303X
- I.S. Class I, Division 1 Groups B-D, 171 °C compliance
- Measure Volts dc, mA, RTDs, thermocouples, frequency and ohms
- Source or simulate volts dc, mA, RTDs, thermocouples, frequency and ohms
- Measure/source pressure using any of eight Fluke 700PEX Pressure Modules
- NIST traceable calibration

8808A Digital Multimeter

Versatile multimeter for manufacturing, development and service applications.

- 5.5 digit resolution
- Basic V dc accuracy of 0.015 %
- Dual display
- NIST traceable calibration

8845A/8846A Precision Multimeters

Precision and versatility for bench or systems applications.

- 6.5 digit resolution
- Basic V dc accuracy of up to 0.0024 %
- Dual display
- /C models include accredited calibration





709



709H



705



707



707EX

mA Loop Calibrators

Fluke loop calibrators are ideal for a wide variety of calibration applications from 4 to 20 mA.

705 Loop Calibrator

A cost-effective, integrated solution for calibration, repair and maintenance of current loops.

- mA sourcing, simulation and measurement
- Simultaneous mA and % of span display
- 24 V loop supply with mA measure
- 0 V dc to 28 V dc measurement to check loop voltage
- NIST traceable calibration

707 Loop Calibrator

A high performance, extremely fast and easy-to-use solution for calibration, repair and maintenance of current loops.

- mA sourcing, simulation and measurement
- 24 V loop supply with mA measure, including 250 Ω HART resistor
- 0 V dc to 28 V dc measurement to check loop voltage
- NIST traceable calibration

707EX IS Loop Calibrator

An intrinsically safe option for use in explosion endangered areas—certified in accordance with the ATEX directive (Ex II 2 G Ex ia IIC T4) in Zones 1 and 2.

- 1 µA resolution for mA source, simulate and measure
- Measures V dc to 28 V
- 0–20 mA or 4–20 mA default startup modes
- HART® compatible resistance is connected in series with the loop supply for compatibility with HART communicators
- NIST traceable calibration

709 Precision Loop Calibrator

Reduces the time it takes to measure or source voltage or current and power up a loop.

- Best-in-class accuracy at 0.01% reading
- Small rugged design operates on six standard AAA batteries
- Intuitive user interface with Quick-Set knob for fast setup, easy use
- Built-in selectable 250 Ω resistor for HART communication
- 24 V dc loop power with mA Measure Mode (–25% to 125%)
- Resolution of 1 µA on mA ranges and 1 mV on voltage ranges
- NIST traceable calibration

709H Precision Loop Calibrator with HART Communications/Diagnostics

Designed to save time and produce high-quality results

- HART Communication built in for easy HART device maintenance
- Best-in-class accuracy at 0.01% reading
- Small rugged design operates on six standard AAA batteries
- Intuitive user interface with Quick-Set knob for fast setup, easy use
- Built-in selectable 250 Ω resistor for HART communication
- 24 V dc loop power with mA Measure Mode (–25% to 125%)
- Resolution of 1 µA on mA ranges and 1 mV on voltage ranges
- NIST traceable calibration





710

710 mA Loop Valve Tester

The Fluke 710 Valve Testing Loop Calibrator is designed to enable users to perform quick, easy tests on HART smart control valves.

- Key valve testing functions include pre-configured valve signature test, speed test, step test, manual test, and bump/partial stroke test
- Key mA loop calibrator functions include mA source, mA simulate, mA read, mA read/loop power, and volts read
- ValveTrack™ Software enables upload to a PC for further in-depth analysis of valve measurements that are logged and recorded to memory



715

715 Volt/mA Calibrator

Outstanding performance, durability and reliability.

- Measure loop current (0-20 mA, 4-20 mA) signals with very high accuracy of 0.015% and 1 mA resolution
- Measure voltage output process signals from PLCs, transmitters
- Source or simulate 24 mA loop current
- Source voltage to 100 mV or 10 V
- 24 V loop supply with simultaneous current measurement
- Enhanced voltage and current measure and source accuracy
- NIST traceable calibration



787B/789

787B ProcessMeter™

The Fluke 787B ProcessMeter™ doubles troubleshooting capabilities by combining the power of a digital multimeter and mA loop calibrator into one tool.

- 20 mA dc current source/measure/simulate
- Simultaneous mA and % of scale readout
- Fluke Connect® compatibility for wireless data logging (with IR3000FC module)
- Precision 1000 V, 440 mA true-rms digital multimeter
- Frequency measurement to 20 kHz
- Min/Max/Average/Hold/Relative modes
- CAT IV 600 V/CAT III 1000 V rating



771/772/773

789 ProcessMeter™

The 789 includes all the popular features of the 787B and adds:

- 24 V loop power supply
- HART mode setting with loop power and a built-in 250 ohm resistor

771 Milliamp Process Clamp Meter

Saves time by making fast, accurate measurements on 4-20 mA signal loops without breaking the circuit.

- 0.01 mA resolution and sensitivity
- Measure mA signals for PLC and control system analog I/O
- Measure 10 to 50 mA signals in older control systems using the 99.9 mA range

772 Milliamp Clamp Meter

Expanded features of the popular 771 mA Clamp Meter by adding loop power and mA sourcing to the capabilities.

- Measure 4 to 20 mA signals with in-circuit measurement
- Simultaneous mA in-circuit measurement with 24 V loop power for powering and testing transmitters
- Source 4 to 20 mA signals for testing control system I/O or I/Ps
- Automatically ramp or step the 4 to 20 mA output for remote testing

773 Milliamp Process Clamp Meter

The premier mA clamp meter, adds advanced troubleshooting features and voltage source/measure for testing voltage I/O. Includes all the features of the 772 plus:

- DC voltage sourcing and measurement, verify 24 V power supplies or test voltage I/O signals
- Scaled mA output provides a continuous mA signal that corresponds to the 4 to 20 mA signal measured by the mA clamp
- Simultaneously source and measure mA signals



Data Acquisition



2638A

Data Acquisition

All Fluke data acquisition products feature unique, built-in universal signal conditioning and a plug-in Universal Input Module to enable you to measure virtually any type of signal without having to purchase additional equipment.

2638A Hydra Series III

Price-performance breakthrough in a stand-alone data acquisition system

- DC accuracy of 0.0024 %
- Thermocouple accuracy of 0.5 °C
- Up to 66 universal differential isolated inputs
- On-screen color trend graphing and analysis
- Easy-to-use menu system for setup and data management
- Input types: ac V, dc V, ac I, dc I, thermocouple, PRT (2, 3, 4 w), thermistor, resistance (2-4 w), frequency
- /C models include accredited calibration



1586A

1586A Super-DAQ Precision Temperature Scanner

- Measure thermocouples, PRTs, thermistors, dc voltage, dc current, and resistance
- Best-in-class temperature measurement accuracy
 - PRTs ± 0.005 °C (using external DAQ STAQ Multiplexer)
 - Thermocouples: ± 0.5 °C (using High-Capacity Module and internal CJC)
 - Thermistors: ± 0.002 °C
- Input channels: Up to 40 isolated universal inputs
- Flexible configuration: Internal High-Capacity Module and/or DAQ-STAQ Multiplexer
- Selectable scan speed: Up to 10 channels per second
- Four modes of operation: Scan, Monitor, Measure, Digital Multimeter (DMM)

Pressure Calibration





717



718/718EX



719/719PRO



721

Digital Pressure Calibrators
Built-in features like mA measure, loop power, switch test and transmitter error calculation make these pressure calibrators powerful tools that are easy to use.

717 Pressure Calibrator

- Rugged, reliable and accurate calibrator with outstanding performance and durability.
- Measure pressure, 0.025 % of full scale with internal sensor up to 690 bar sensor (10000G model)
 - Measure mA with 0.015 % accuracy and 0.001 mA resolution, while sourcing 24 V loop power
 - Measure pressure to 700 bar using one of 29 Fluke 700Pxx Pressure Modules
 - NIST traceable calibration

718 Pressure Calibrator with Pump

- Provides a total pressure calibration solution for transmitters, gauges and switches.
- Pressure source and milliamp measurement to calibrate and maintain almost any pressure device
 - Integrated pump is easily cleaned when accidentally exposed to fluids that reduces cost of ownership and repairs and enables servicing the pump in the field
 - 0, 2, 7 and 20 bar ranges mean few extra tools required
 - NIST traceable calibration

718EX IS Pressure Calibrator

- A powerful, intrinsically safe and self-contained pressure calibrator for use in explosion endangered areas.
- ATEX II 1G Ex ia IIC T4 compliant
 - Built-in pressure/vacuum hand pump, with fine adjust vernier and bleed valve
 - 2 bar, 7 bar and 20 bar ranges
 - Pressure measurement to 200 bar using any of eight intrinsically safe Fluke 700Pxx Pressure Modules
 - NIST traceable calibration

719 and 719PRO Portable Electric Pressure Calibrators

- Calibrate and test pressure devices quickly and easily with the built-in electric pump.
- Source mA with simultaneous pressure measurement to test valves and I/Ps
 - Simulate mA signals to troubleshoot 4-20 mA loops
 - Power transmitters during test using 24 V loop supply with simultaneous mA measurement
 - New 20 bar range, generate up to 20 bar, with internal Electric pump (719PRO)
 - Precision temperature measurement combined accuracy of ± 0.25 °C when using 720 RTD probe (optional accessory for use with 719PRO)
 - NIST traceable calibration

721 Dual Range Pressure Calibrator

- Two measurement ranges plus *temperature measurement make the 721 ideal for gas custody transfer calibration applications.
- Fourteen models
 - Up to (3) displayed measurement simultaneously
 - Simplified user interface for ease of use
 - Rugged, durable design with protective holster
 - High accuracy, 0.025% total measurement uncertainty for one year
 - Pt100 RTD input for precise temperature measurement, accurate to 0.1°C
 - Requires 720RTD probe sold separately as an accessory
 - NIST traceable calibration





729



750P



700PEX



P5510



P5513

729 Automatic Pressure Calibrator

Portable automatic pressure calibrator simplifies pressure calibration.

- Automatic pressure generation and regulation to 20 bar
- Easily document the process using onboard test templates
- Automatic internal fine-pressure adjustment
- Measure, source and simulate 4 to 20 mA signals
- 24V loop power for powering transmitters for tests
- HART communication for testing HART smart transmitters

750P Pressure Modules

A full range of differential, gage, absolute, vacuum, dual and intrinsically safe pressure modules are available, from 2.5 mBar to 690 Bar.

- Best-in-class 0.025 % reference uncertainty
- Rugged, chemical-resistant packaging
- Temperature compensated 0°C to 50°C
- Digital communication to calibrators; no analog losses or errors
- NIST traceable calibration

700PEX IS Pressure Modules

Intrinsically safe pressure modules to create a complete pressure test solution.

- Certified by CSA: I.S. Class I, Div 1, Groups A-D T4, Ta = 0 °C to 50 °C
- ATEX II 1G Ex ia IIC T4 compliant
- NIST traceable calibration

Pressure Comparators and Master Gauges

Precise pressure generation for comparing a device under test to a master gauge.

P5510 Gas Pressure Comparator

Easy, efficient pressure and vacuum generation in a single device.

- Pressure to 2 MPa
- Vacuum to -80 kPa

P5513 Gas Pressure Comparator

High quality, precise gas pressure control.

- Precise pressure regulation to 210 MPa with high quality needle valves
- Built-in screw press for fine pressure adjustment
- Optional vacuum/pressure pump, -80 kPa to 2 MPa





P5514



P5515



2700G

P5514 Hydraulic Pressure Comparator

Easy, efficient hydraulic pressure generation.

- Generate and precisely adjust pressure to 70 MPa
- Compatible with a wide range of fluids

P5515 Hydraulic Pressure Comparator

High quality, precise hydraulic pressure generation and control.

- Generate and precisely adjust pressure to 140 MPa
- Integrated hand pump for system priming and large volume applications
- Compatible with a wide range of fluids

700G Precision Pressure Gauge Calibrator

Rugged construction for reliable measurements in the field.

- Twenty-three ranges from 1 bar to 690 bar and 0.05 % accuracy
- Combine with a comparator kit for a complete solution
- Four new absolute pressure measurement ranges
- Use the 700G/TRACK Software to upload over 8,000 logged pressure measurements
- Up to 1500 hours battery life
- I.S. rating, CSA; Class 1, Div 2, Groups A-D rating, ATEX: rating: II 3 G Ex nA IIB T6
- NIST traceable calibration

2700G Series Reference Pressure Gauges

Best-in-class accuracy from a master pressure gauge.

- Precision pressure measurement from 100 kPa to 70 MPa.
- Accuracy to $\pm 0.02\%$ of full scale
- Combine with the P55XX Pressure Comparators for a complete benchtop pressure calibration solution
- /C models include accredited calibration



700G

P5510-2700G

P5513-2700G

P5514-2700G

P5515-2700G

Manual Pressure Calibrators

The Fluke Calibration pneumatic calibrators are an easy-to-use alternative to traditional deadweight testers.

P55xx-2700G

These pressure calibrators are conveniently bundled with up to six 2700G Reference Pressure Gauges for a complete, benchtop pressure calibration solution to provide the accuracy, reliability, and capability you need to calibrate dial gauges, digital test gauges and pressure transmitters.

- Best-in-class accuracy of 0.02% full scale for each 2700G Reference Gauge.
- Expand lower range capability with additional 2700G Reference Gauges
- Adaptors to provide hand tight connection to common NPT, BSP, and metric fitting types
- Included reference gauges are battery operated and capable of using line power too
- Portable with a sturdy carrying case



700HPPK

700HPPK Pneumatic Test Pump Kit

The rugged, portable way to generate pressure in the field quickly, safely and easily.

- Generates and adjusts pneumatic pressure up to 21 MPa
- Rugged and stable enough to use almost anywhere, on any surface
- Reaches pressure in 20 seconds to full scale into a 30 cm³ volume

Reference Pressure Calibrators

Portable, high-quality pressure gauges

3130 Portable Pressure Calibrator

Everything you need for highly accurate calibrations of pneumatic field instruments.

- Measure and generate pressures from vacuum to 2 MPa
- Accuracy of $\pm 0.025\%$ reading to $\pm 0.01\%$ FS
- Works with compressed plant air or internal pump
- 24 V loop power and electrical measurement for transmitters and switches
- Compatible with Fluke 750P pressure modules
- NiMH battery
- /C models include accredited calibration



3130

Bench Deadweight Testers
Deadweight testers are highly accurate, robust and flexible pressure measurement standards capable of calibrating a wide range of instruments.

P3010 Single Piston Gas Deadweight Tester

A high quality, high performance gas deadweight tester.

- 0.015 % of reading accuracy (0.008 % optional)
- Ranges cover from -100 kPa vacuum to 3.5 MPa pressure
- Integrated vacuum/pressure pump available to 2 MPa
- Accredited calibration



P3010/P3020/P3030

P3020 Dual Piston Gas Deadweight Tester

Unique suspended piston design offers vacuum and pressure calibration in a single instrument.

- 0.015 % of reading accuracy (0.008 % optional)
- Ranges cover from 1.5 kPa to 3.5 MPa
- All models feature vacuum measurement to -100 kPa
- Integrated vacuum/pressure pump available to 2 MPa
- Accredited calibration

P3030 High Pressure Gas Deadweight Tester

Innovative liquid-lubricated piston offers low drop rates and high tolerance to contamination.

- 0.015 % of reading accuracy (0.008 % optional)
- Ranges cover from 100 kPa to 14 MPa
- Integrated control valves and screw press for fine adjustment
- Accredited calibration





P3110/P3120/P3210/P3220



P3800



6531



6532

P3110 Single Piston Oil Deadweight Tester

High quality, high performance, easy to use oil pressure calibration.

- 0.015 % of reading accuracy (0.008 % optional)
- Ranges cover from 100 kPa to 140 MPa
- Integrated pressure generation and control is standard
- Accredited calibration

P3800 High Pressure Oil Deadweight Tester

High performance, easy to use very high pressure oil calibration.

- 0.02 % of reading accuracy (0.015 % optional)
- Ranges up to 400 MPa
- Integrated pressure generation, intensifier and control
- Accredited calibration

6531 Electronic Deadweight Tester

A digital alternative to the traditional deadweight tester.

- 0.02 % of reading from 10 % to 100 % of instrument range (10:1 turndown)
- Ranges from 7 MPa to 200 MPa
- Integrated hydraulic pressure generation and control
- Compatible with water and a wide range of oils and other fluids
- Onboard test routines, data storage, and other advanced features
- Accredited calibration

P3120 Dual Piston Oil Deadweight Tester

Dual piston design offers maximum hydraulic pressure calibration workload coverage.

- 0.015 % of reading accuracy (0.008 % optional)
- 100 kPa to 110 MPa in a single instrument
- Integrated pressure generation and control is standard
- Accredited calibration

6532 Extended Range Electronic Deadweight Tester

All the features of model 6531 with extended pressure range for maximum workload coverage.

- 0.02 % of reading from 1 % to 100 % of instrument range (100:1 turndown)
- Models with full scale ranges from 70 MPa to 200 MPa
- Accredited calibration

P3210 Single Piston Water Deadweight Tester

Specially designed to use water as a test medium.

- 0.015 % of reading accuracy (0.008 % optional)
- Ranges cover from 100 kPa to 70 MPa
- Integrated pressure generation and control is standard
- Accredited calibration

P3220 Dual Piston Water Deadweight Tester

Dual piston design offers maximum water pressure calibration workload coverage.

- 0.015 % of reading accuracy (0.008 % optional)
- 100 kPa to 70 MPa in a single instrument
- Integrated pressure generation and control is standard
- Accredited calibration



Temperature Calibration





712B



9142/9143/9144

Multifunction Field Temperature Sources

Fast, lightweight and portable with precision temperature control traceable to national standards. Suitable for calibration of thermocouples, RTDs, PRTs, and other temperature sensors.



714B

714B Thermocouple Calibrator

Highly accurate, full featured easy-to-use, single-function thermocouple temperature calibrator.

- Measures and simulates 17 thermocouple types and millivolts
- Measures 4 to 20 mA signals while simultaneously sourcing a temperature signal
- Comes with a magnetic hanging tool designed in for convenient hands-free operation
- Features configurable 0% and 100% source settings for quick 25% linearity checks

9142 Field Metrology Well

Maximizing portability, speed, and functionality for the industrial process environment.

- -25 °C to 150 °C temperature range
- Display accuracy of ± 0.2 °C over full range
- Built-in two-channel readout for PRT, RTD, thermocouple, 4-20 mA current
- Optional built-in reference thermometer readout
- Accredited calibration



724

724 Temperature Calibrator

Powerful and easy to use to measure and source functions for testing and calibrating almost any temperature instrument.

- Measure RTDs, thermocouples, ohms, and volts to test sensors and transmitters
- Source/simulate thermocouples, RTDs, volts, and ohms to calibrate transmitters
- Perform fast linearity tests with 25 % and 100 % steps
- NIST traceable calibration

9143 Field Metrology Well

Maximizing portability, speed, and functionality for the industrial process environment.

- 33 °C to 350 °C temperature range
- Display accuracy of ± 0.2 °C over full range
- Built-in two-channel readout for PRT, RTD, thermocouple, 4-20 mA current
- Optional built-in reference thermometer readout
- Accredited calibration

Handheld Temperature Calibrators

Suitable for calibrating temperature transmitters, panel meters, and other devices that connect to temperature sensors.

712B RTD Calibrator

Provides highly accurate, easy-to-use, single-function RTD temperature calibration.

- Measures and simulates 13 different RTD types and resistance
- Measures 4 to 20 mA signals while simultaneously sourcing a temperature signal
- Comes with a magnetic hanging tool designed in for convenient hands-free operation
- Features configurable 0% and 100% source settings for quick 25% linearity checks

9144 Field Metrology Well

Precision calibration with fast temperature ramp-up rates for the industrial process environment.

- 50 °C to 660 °C temperature range
- Heat to 660 °C in 15 minutes
- Display accuracy from ± 0.35 °C at 420 °C to ± 0.5 °C at ± 660 °C
- Optional built-in reference thermometer readout
- Accredited calibration



9100S



9102S



9103/9140



9150



9009



9190A

Field Temperature Sources

Portable and flexible temperature-controlled dry-wells suitable for high-speed calibrations or certifications of thermocouples, RTDs, PRTs and other temperature sensors

9100S Handheld Dry-Well

World's smallest, lightest and most portable dry-well.

- Smallest dry-wells in the world
- Ranges from 35 °C to 375 °C
- Accuracy to ± 0.25 °C, stability of ± 0.07 °C at 50 °C
- NIST traceable calibration

9140 Field Dry-Well

Lightweight and portable field dry-well small enough to easily carry in one hand.

- 35 °C to 350 °C
- Accuracy to ± 0.5 °C
- Stability to ± 0.03 °C at 50 °C and ± 0.05 °C at 350 °C
- NIST traceable calibration

9102S Handheld Dry-Well

High-performance, convenient and easy-to-use handheld dry-well.

- Smallest dry-wells in the world
- Ranges from -10 °C to 122 °C
- Accuracy to ± 0.25 °C, stability of ± 0.05 °C (full range)
- NIST traceable calibration

9150 Thermocouple Furnace

Convenient, portable thermocouple furnace.

- 150 °C to 1200 °C
- Stability of ± 0.5 °C over full range
- NIST-traceable calibration included
- RS-232 port standard
- NIST traceable calibration

9009 Dual-Well Dry-Well

Two-in-one dry-well increases portability and productivity.

- Temperatures from -15 °C to 350 °C in one unit
- Display accuracy: hot block: ± 0.6 °C; cold block: ± 0.2 °C
- Rugged, lightweight, water resistant enclosure
- NIST traceable calibration

9190A Ultra-Cool Field Metrology Well

Very low temperatures, with no fluids and best-in-class stability

- Wide temperature range from -95 °C to 140 °C
- Best-in-class stability: ± 0.015 °C full range
- Accuracy using built-in reference thermometer readout: ± 0.05 °C full range
- Display accuracy: ± 0.2 °C full range
- Optional built-in two-channel readout for PRT, RTC, TC, 4-20 mA and reference thermometer
- Accredited calibration

9103 Field Dry-Well

Great performance in a portable instrument.

- -25 °C to 140 °C
- Accuracy to ± 0.25 °C
- Stable to ± 0.02 °C at -25 °C and ± 0.04 °C at 140 °C
- NIST traceable calibration



6102/7102/7103

**6102/7102/7103
Micro-Baths**

Calibrate a variety of probe diameters—no sleeves required.

- Three models covering temperatures from $-30\text{ }^{\circ}\text{C}$ to $200\text{ }^{\circ}\text{C}$
- World's smallest portable calibration baths
- Stability to $\pm 0.015\text{ }^{\circ}\text{C}$
- NIST traceable calibration

**6109A/7109A Portable
Calibration Baths**

Calibrate up to four tri-clamp sanitary sensors, or a batch of sanitary RTDs and temperature transmitters, at the same time.

- Wide temperature range covers most clean process applications:
 - 6109A: $35\text{ }^{\circ}\text{C}$ to $250\text{ }^{\circ}\text{C}$
 - 7109A: $-25\text{ }^{\circ}\text{C}$ to $140\text{ }^{\circ}\text{C}$
- Excellent display accuracy of $\pm 0.1\text{ }^{\circ}\text{C}$ provides 4:1 test uncertainty ratio (TUR) for critical applications
- Easy to transport up stairs and across catwalks
- Stainless steel casing withstands harsh sterilizing chemicals and is rust proof—perfect for clean room use
- Easy to use and maintain



6109A/7109A

**9170/9171/9172/9173
Metrology Wells**

Best possible accuracy in a dry-block calibrator

- Best performing industrial temperature sources in the world (stability as good as $\pm 0.005\text{ }^{\circ}\text{C}$)
- Immersion depth to 203 mm
- Optional built-in readout reads reference PRTs to $\pm 0.006\text{ }^{\circ}\text{C}$
- Ranges:
 - 9170: $-45\text{ }^{\circ}\text{C}$ to $140\text{ }^{\circ}\text{C}$
 - 9171: $-30\text{ }^{\circ}\text{C}$ to $155\text{ }^{\circ}\text{C}$
 - 9172: $35\text{ }^{\circ}\text{C}$ to $425\text{ }^{\circ}\text{C}$
 - 9173: $50\text{ }^{\circ}\text{C}$ to $700\text{ }^{\circ}\text{C}$
- NVLAP accredited calibration ONLY with -R model



9170/9171/9172/9173



4180/4181

**Infrared Temperature
Sources**

Bench and field precision infrared calibrators for accurate and reliable calibrations of IR thermometers.

**4180/4181 Precision
Infrared Calibrators**

Accredited performance for point and shoot calibrations.

- Calibrated radiometrically for meaningful, consistent results
- Accredited calibration included
- Accurate, reliable performance from $-15\text{ }^{\circ}\text{C}$ to $500\text{ }^{\circ}\text{C}$
- Large 152 mm (6 in) diameter target
- Accredited radiometric calibration report



9132



9133

**9132/9133 Field
Infrared Calibrators**

Precision when you need it for infrared temperature calibration.

- Verify IR pyrometers from $-30\text{ }^{\circ}\text{C}$ to $500\text{ }^{\circ}\text{C}$
- RTD reference well for contact temperature measurement
- NIST traceable contact calibration



1551A Ex/1552A Ex

Thermometer Standards
Delivering exceptional accuracy, wide measurement range, and designed to go where you work.

1551A Ex/1552A Ex “Stik” Thermometer

The best substitute for precision mercury-filled glass thermometers.

- Accuracy of $\pm 0.05\text{ }^{\circ}\text{C}$ ($\pm 0.09\text{ }^{\circ}\text{F}$) over full range
- Intrinsically safe (ATEX and IECEx compliant)
- Two models to choose from (-50 $^{\circ}\text{C}$ to 160 $^{\circ}\text{C}$ or -80 $^{\circ}\text{C}$ to 300 $^{\circ}\text{C}$)
- NVLAP-accredited, NIST-traceable calibration



1523/1524

1523/1524 Handheld Thermometer Readout

Measure, graph and record three sensor types with one tool.

- High accuracy: PRTs: $\pm 0.011\text{ }^{\circ}\text{C}$; Thermocouples: $\pm 0.24\text{ }^{\circ}\text{C}$; Thermistors: $\pm 0.002\text{ }^{\circ}\text{C}$
- A simple user interface to see trends quickly
- Smart connectors to load probe information automatically
- Traceable cal as standard. -CAL versions with accredited cal



1502A/1504

1502A/1504 Thermometer Readouts

Best performance thermometers in their price range.

- Single-channel reference thermometers, accurate to $\pm 0.006\text{ }^{\circ}\text{C}$ (meter only)
- Two models to choose from—reading PRTs or thermistors
- Best price/performance package
- Accredited calibration



1529

1529 Four-Channel Thermometer Readout

Lab-quality accuracy on four channels for PRTs, thermistors and thermocouples.

- Accuracy of $\pm 0.0025\text{ }^{\circ}\text{C}$ (meter only)
- Displays eight user-selected data fields from any channel
- Logs up to 8,000 readings with date and time stamps
- Accredited calibration



1620A

Ambient Conditions Monitor

For precise measurement and recording of ambient temperature and humidity conditions wherever calibrations take place.

1620A Precision Thermo-Hygrometer

The most accurate temperature and humidity graphical data logger on the market.

- Superior accuracy
- Network enabled
- Powerful logging and analysis tools
- Measures temperature to $\pm 0.125\text{ }^{\circ}\text{C}$ and humidity to $\pm 1.5\%$ on two channels
- NIST-traceable NVLAP accredited temperature and humidity calibration

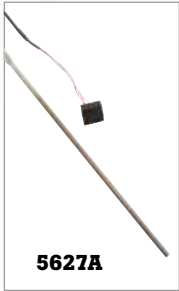

5627A



5615

Precision PRTs

High accuracy reference temperature measurements in temperature sources on the bench or in the field.

5627A Precision Industrial PRT

- Vibration and shock resistant
- Calibration accuracy of $\pm 0.046\text{ }^{\circ}\text{C}$ at $0\text{ }^{\circ}\text{C}$
- Available with a 90° bend
- NVLAP-accredited calibration included, lab code 200706-0



5608/5609/5609-BND

5615 Secondary Reference Temperature Standards

- $-200\text{ }^{\circ}\text{C}$ to $420\text{ }^{\circ}\text{C}$
- Calibrated accuracy $\pm 0.010\text{ }^{\circ}\text{C}$ at $0\text{ }^{\circ}\text{C}$
- NVLAP-accredited calibration included, lab code 200706-0

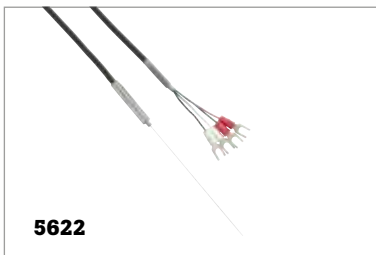

5622

5608/5609/5609-BND Secondary Reference PRTs

Drift rate of $\pm 0.01\text{ }^{\circ}\text{C}$ at $0\text{ }^{\circ}\text{C}$ after 100 hours at max temperature.

- 5608: $-200\text{ }^{\circ}\text{C}$ to $500\text{ }^{\circ}\text{C}$ (80 mm minimum immersion)
- 5609: $-200\text{ }^{\circ}\text{C}$ to $670\text{ }^{\circ}\text{C}$ (100 mm minimum immersion)
- Comes with certificate of compliance - optional NVLAP-accredited calibration



5626/5628



5618B

5622 Fast Response PRTs

- Time constants as fast as 0.4 seconds
- Small probe diameters ranging from 0.5 mm to 3.2 mm (four models available)
- Available as DIN/IEC Class A PRTs or with optional NVLAP-accredited calibration, lab code 200348-0

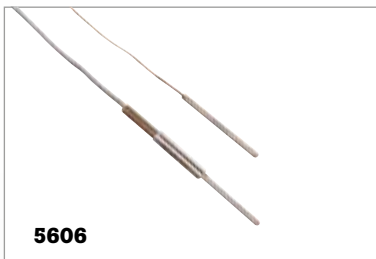

5606

5618B Small Diameter Industrial RTD

Fast response for time-dependent measurements.

- Small diameter sheath, 3.2 mm (0.125 in)
- Excellent stability
- Includes ITS-90 coefficients
- NVLAP accredited calibration, lab code 200706-0

5606 Full Immersion PRT

Fully immerse PRT transition junction inside freezers or furnaces.

- Transition junction designed to withstand full temperature range of probe
- $-200\text{ }^{\circ}\text{C}$ to $160\text{ }^{\circ}\text{C}$
- Calibration accuracy of $\pm 0.05\text{ }^{\circ}\text{C}$ (full range)
- Optional NVLAP accredited calibration

Thermistors

Providing accurate and rugged temperature measurements from $0\text{ }^{\circ}\text{C}$ to $100\text{ }^{\circ}\text{C}$.

5610/5611/5611T Secondary Reference Thermistor Probes

Economical lab-grade thermistor probes with low drift susceptibility.

- Short-term accuracy to $\pm 0.01\text{ }^{\circ}\text{C}$; one-year drift $< \pm 0.01\text{ }^{\circ}\text{C}$
- 5610: 3.2 mm diameter stainless steel sheathed thermistor
- 5611: 1.5 mm diameter (tip) silicone coated thermistor
- 5611T: 3 mm diameter (tip) PTFE encapsulated thermistor

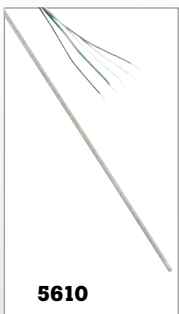

5610

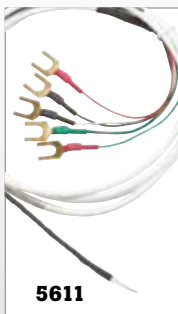

5611

5626/5628 Secondary SPRT, PRT, Temperature Sensors

- Range to $661\text{ }^{\circ}\text{C}$
- Meets all ITS-90 requirements for resistance ratios
- Rtp drift $< 20\text{ mK}$ after 500 hours at $661\text{ }^{\circ}\text{C}$
- Calibrated accuracy of $\pm 0.006\text{ }^{\circ}\text{C}$ at $0\text{ }^{\circ}\text{C}$
- NVLAP accredited fixed point calibration



5611T

Software/ Accessories

Process Calibration Software

750 SW DPC/TRACK2 Software™

DPC/TRACK2 Software is a specialized calibration management database that can help you manage your instrumentation and address the documentation requirements of quality programs and regulations. With DPC/TRACK2 and a 754 DPC you can:

- Manage your inventory of tags and instruments, schedule for calibration
- Create tag specific procedures with instructions and comment
- Load those procedures to your DPC, and later upload the results to your PC
- Select and execute automated as found/as left procedures in the field, automatically capturing results
- Examine the calibration histories of your tags and instruments and print reports
- Import and export instrument data and procedures as ASCII text
- Import legacy DPC/TRACK data

700G/Track

Easy-to-use software for managing instruments and calibration data.

- Enables data download and logging configurations to the 700G Series gauges for a remote logging event
- Configure logging event reading rate, duration and measurement units
- Upload measurements logged remotely and display or export measurements

Temperature Calibration Software

9938 MET/TEMP II Temperature Calibration Software v5.0

New version of the proven solution for automated temperature calibration

- Compatible with Windows 7 and 8 operating systems
- Adds support for 9190A Field Metrology Well and 9118A Thermocouple Furnace
- Fully automated calibration of RTDs, TCs, thermistors and many heat sources
- Calibrates up to 100 sensors at up to 40 temperature points

TQSoft and TQAero Thermal Validation Software

For FDA 21 CFR Part 11 and AMS 2750 Compliant Data Collection.

- Support for Fluke 2638A and 1586A, for enhanced data collection and reporting in regulated industries
- Easy menu system and toolbar
- Test equipment preparation and sensor calibration
- Data security, audit trail, and compliance reports

LogWare

Turn a Fluke Calibration single-channel handheld or 1502A/1504 readout into a real-time data logger.

- Collects realtime data
- Calculates statistics and displays customizable graphs
- Allows user-selected start times, stop times and sample intervals

LogWare II

Turn any Fluke Calibration multi-channel thermometer readout into a real-time data logger.

- Collects real-time data using Fluke Calibration multi-channel readouts
- Calculates statistics and displays customizable graphs
- Allows user-selected start times, stop times and sample intervals

LogWare III

Remotely monitor and log a virtually unlimited number of concurrent log sessions into a central data repository.

- Up to two temperature and two humidity inputs for each DewK
- Customize your graph trace color, alarms, and statistics as you go

Process Tools Accessories

700HTP-2 Hydraulic Test Pump

The 700HTP-2 is designed to generate pressures up to 10,000 psi/700 bar. Use the Fluke 700PRV-1 adjustable relief valves to limit pressures from 1360 psi to 5450 psi. Use the 700HTH-1 test hose to connect from the pump to the device under test.

700HTH-1 Hydraulic Test Hose

The 700 HTH is a 700 bar test hose that connects to a calibration unit under test from a Fluke 700HTP hydraulic test pump.

700PTP-1 Pneumatic Test Pump

The 700PTP-1 is a handheld pressure pump designed to generate either vacuum to -11.6 psi/-0.8 bar or pressure to 600 psi/40 bar.

700LTP-1 Low Pressure Test Pump

Hand operated pressure pump designed to generate either vacuum to -13 psi/-0.90 bar or pressures to 100 psi/6.9 bar. Ideal for low pressure applications requiring accurate low pressure testing.

700PMP Pressure Pump

The 700PMP is a hand-operated pressure pump to provide pressures up to 10 bar. Output fitting is 1/8 FNPT.



700HTP-2



700HTH-1



700PTP-1



700LTP-1



700PMP

Pressure Applications



INTRODUCTION

Process pressure devices provide critical process measurement information to process plant's control systems. The performance of process pressure instruments are often critical to optimizing operation of the plant or proper functioning of the plant's safety systems. Process pressure instruments are often installed in harsh operating environments causing their performance to shift or change over time. To keep these devices operating within expected limits requires periodic verification, maintenance and calibration. There is no one size fits all pressure test tool that meets the requirements of all users performing pressure instrument maintenance.

APPLICATION SELECTION GUIDE

										
Model number	754	721/ 721Ex	719 Pro	719	718	717	700G	3130	2700G	Deadweight Testers
Application										
Calibrating pressure transmitters (field)	■	■	Ideal	■	■	■		■		
Calibrating pressure transmitters (bench)	■	■	■	■	■	■		Ideal		■
Calibrating HART Smart transmitters	Ideal									
Documenting pressure transmitter calibrations	Ideal									
Testing pressure switches in the field	Ideal	■	■	■	■	■		■		
Testing pressure switches on the bench	■	■	■	■	■	■		Ideal		
Documenting pressure switch tests	Ideal									
Testing pressure switches with live (voltage) contacts	Ideal									
Gas custody transfer computer tests	■	Ideal	■							
Verifying process pressure gauges (field)	Ideal	■	■	■	■	■	■			
Verifying process pressure gauges (bench)	■	■	■	■	■	■		■	■	Ideal
Logging pressure measurements	■						Ideal		■	
Testing pressure devices using a reference gauge									Ideal	
Hydrostatic vessel testing							Ideal			
Leak testing (pressure measurement logging)	■						Ideal			

Products noted as "Ideal" are those best suited to a specific task.

Model 754 requires the correct range 750P pressure module for pressure testing.

Model 753 can be used for the same applications as model 754 except for HART device calibration.

Model 725 and 726 can be used for the same applications as model 753 except for documenting and live contact testing of switches.

Calibrating a HART smart pressure transmitter



Pressure transmitter manufacturers have improved the accuracy and technology designed into these smart pressure measurement devices. Many conventional calibration tools have become inadequate or simply unable to test and calibrate these high accuracy pressure transmitters. Better test solutions are required.

Verifying and documenting the performance and adjusting a HART smart pressure transmitter can require a bucket full of tools. Performing this task with a HART enabled calibrator like the Fluke 754 simplifies the task and reduces what you need to carry.

Before going to the field: install the pressure module adapter to the hand pump with thread seal. Once the adapter is properly installed on the pump, changing modules to different pressure ranges is a snap, no tools required.

To get the accuracy needed: to test these new high accuracy transmitters match the pressure measurement standard range closely to the device tested. For example, use a 100 psi pressure module to calibrate and test a transmitter ranged at 100 psi. Industry standards suggest the measurement standard should be 4-10 times more accurate than the device being tested so best-in-class accuracy is required.

The Fluke 754 utilizes the 750P series pressure modules and has built-in HART functionality to enable smart trims on transmitters. It can also document transmitter performance before and after adjustment and calculate pass/fail errors.

Suggested test tools



Fluke 754 Documenting Process Calibrator-HART
See pg 5



Fluke 700G Precision Pressure Gauge Calibrator
See pg 13



Fluke 750P Series Pressure Modules
See pg 12



Fluke 700PTP-1 Pneumatic Test Pump
See pg 23

TECH TIPS

Sometimes it is necessary to trim the input sensor of the transmitter more than once. It is critical that the pressure module be zeroed before test and adjustment. For best adjustment success:

- After pressing Fetch for the pressure measurement, select the trim button quickly before the pressure measurement changes.
- Give the measured mA and pressure time to settle for best measurement results.
- Always de-bug the pressure test setup for leaks in the shop before going to the field, including installing the pressure module connection adapter to the hand pump.
- If the full scale value of the transmitter is less than 25 % of the full scale of the pressure module, select a lower range pressure module for best results.
- If performing higher pressure calibrations with a hydraulic pump, use the correct fluid such as mineral oil or de-ionized water. Standard tap water will leave deposits in the pump and cause erratic operation, leaks or difficulty priming.
- If the pass/fail accuracy is set at the limits for the transmitter, adjust the transmitter if the errors are greater than 25 % of limits.
- If the errors are less than 25 % of limits, it might be best to not adjust the transmitter as adjusting might make it less accurate.

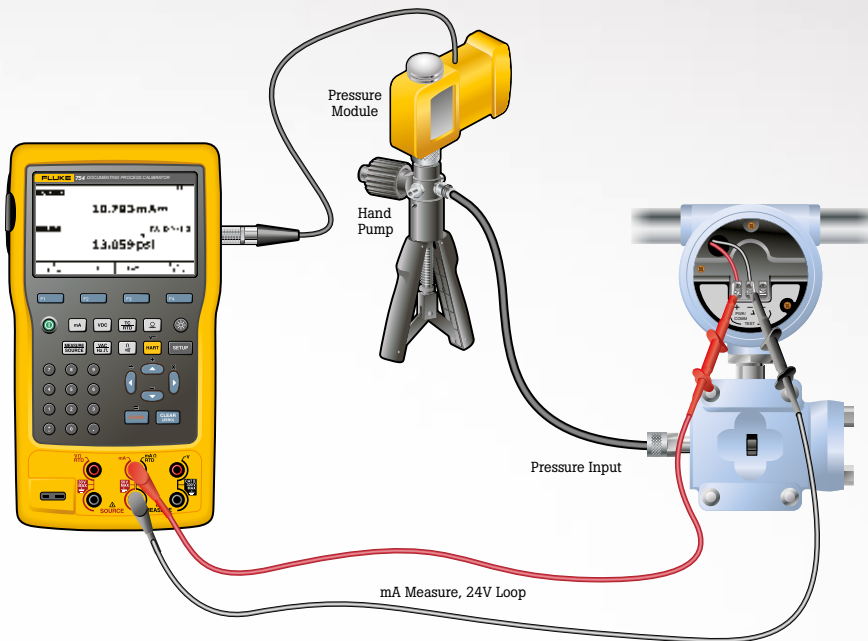

To perform the test:

- STEP 1** Isolate the transmitter from the process being measured and its loop wiring. If measuring the mA signal across the transmitter test diode leave the wires intact, but note this method does not give the best mA measurement accuracy.
- STEP 2** Connect the mA measurement jacks of the 754 to the transmitter.
- STEP 3** Connect the pressure module cable to the 754 and connect the transmitter test hose from the hand pump to the transmitter.
- STEP 4** Press the HART button on the calibrator to see the configuration of the transmitter.
- STEP 5** Press HART again and the calibrator will offer the correct measure/source combination for the test. If documenting the calibration press As-Found, input the test tolerance and follow the prompts. If the measured mA signal at the test points is found within tolerance the test is complete. If not, adjustment is required.
- STEP 6** Select adjust and trim the transmitter's pressure zero, mA output signal and input sensor.
- STEP 7** After adjustment select As-Left, document the condition of the transmitter after adjustment and if the test passes, it is complete.

Pressure transmitter calibration – at the bench



Technicians calibrate at the bench to ensure calibrations are effective and don't result in degradation of performance. They ensure that all components are in good working order prior to installation, and can evaluate them when component failure is suspected. The bench provides a stable ambient environment for calibration, an opportunity to use the most accurate equipment, and protection from factory conditions during the commissioning, testing, and calibration of pressure transmitters.

Suggested test tools



Fluke 3130
Portable Pressure
Calibrator
See pg 14



Fluke 754
Documenting
Process
Calibrator-HART
See pg 5



Fluke 719Pro
Electric Pressure
Calibrator
See pg 11



P3000 Hydraulic
Deadweight Testers
See pg 14



Fluke 700PTP-1
Pneumatic
Test Pump
See pg 23

TECH TIPS 

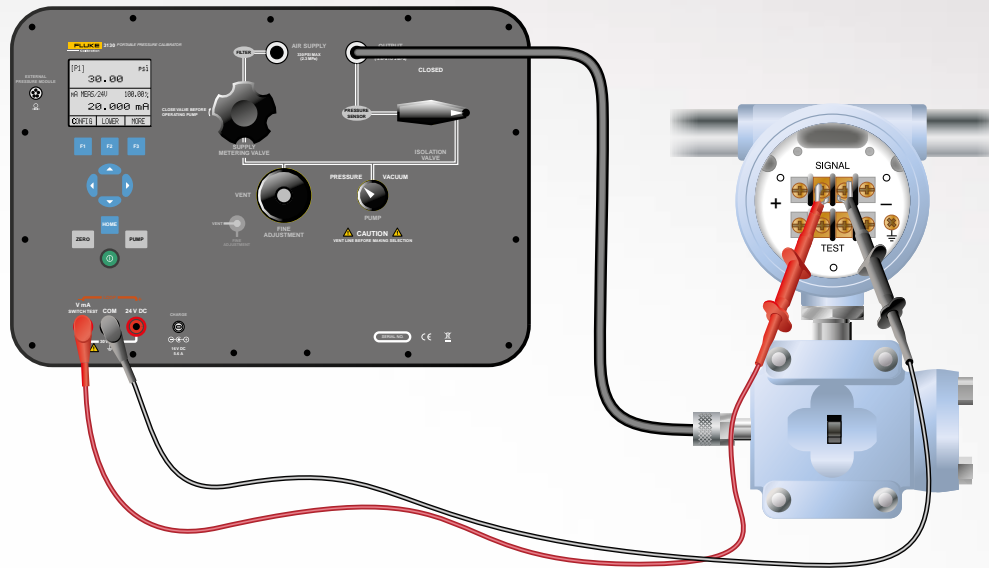

To perform the test:

- STEP 1** Connect the transmitter test hose from the calibrator to the transmitter
- STEP 2** Connect the mA measurement jacks of the calibrator to the transmitter
- STEP 3** Set the pressure/vacuum selection knob to the necessary function
- STEP 4** Close the vent knob and supply metering valve
- STEP 5** Apply pressure or vacuum from the pump by holding down the pump button and release when the necessary pressure is reached
- STEP 6** Correct the pressure with the fine pressure adjustment
- STEP 7** Read the reference pressure and the current output of the transmitter from the display
- STEP 8** Repeat for all test points. If the measured mA signal at the test points is found within tolerance the test is complete. If not, then adjustment is required.

- Inaccurate calibration equipment will only degrade the performance of the transmitter.
- Manufacturers recommend using precise calibration equipment under stable, ambient conditions for best results.
- Commission transmitters at the bench so security settings and protection for failure modes can be set before exposing transmitter electronics to factory conditions.

Pressure switch testing— manual approach



Accurate calibration of pressure switches is a critical step in ensuring process quality and the safe operation of equipment. The setup is similar to pressure gauge calibration except now a voltage or continuity across a set of switch contacts needs to be read either by a (Digital Multimeter) DMM or the calibrator. The purpose of the calibration is to detect and correct errors in the set point and deadband of the pressure switch. Calibrators can save you time by reducing steps and reducing the amount of equipment you have to bring to the job. With the right calibrator the entire process can be automated.

Suggested test tools



Fluke 754
Documenting
Process
Calibrator-HART
See pg 5



Fluke 719Pro
Electric Pressure
Calibrator
See pg 11



Fluke 3130-G2M
Portable Pressure
Calibrator
See pg 14



Fluke 750P Series
Pressure Modules
See pg 12



Fluke 700PTP-1
Pneumatic
Test Pump
See pg 23

TECH TIPS 

When you use a Fluke 754 or 3130 to automate the pressure switch calibration, vary the applied pressure slowly, back and forth across the setpoint and reset points. The display will make it apparent that the set/reset has changed and the actuals will be logged.

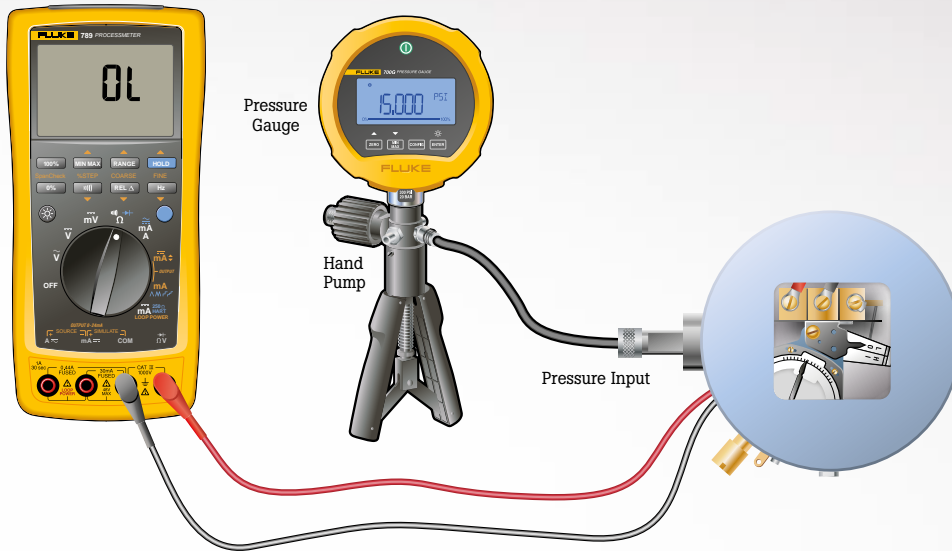

To perform the test:

Setup

- STEP 1** Safely disconnect the device from the process it controls.
- STEP 2** Connect the calibrator or DMM to the common and NO (normally open) output terminals of the switch. The DMM or calibrator will measure an “open circuit”. If measuring continuity. If measuring V ac be sure the tool is properly rated for the voltage being measured.
- STEP 3** Connect the pressure switch to a pressure source such as a hand pump connected to a gauge.

Rising pressure

- STEP 4** Increase the source pressure to the setpoint of the switch until the switch changes state from open to close. Manually record the pressure value when the DMM indicates a “short circuit” or if using a calibrator it will record the value for you.

Falling pressure

- STEP 5** Continue to increase the pressure until the maximum rated pressure. Slowly reduce the pressure until the switch changes state again, and resets from closed to open, then record the pressure.

Calculation

- STEP 6** The setpoint pressure was recorded when the pressure was rising. The deadband value is the difference between the rising setpoint pressure and the falling pressure reset point.

Pressure switch testing—documented



Classic methods for pressure switch testing have been superseded with the introduction of new pressure test tools. Today most pressure switches are tested with a pressure gauge mounted to a pump to supply and measure pressure, and a DMM set to continuity to verify the opening and closing of the switch. The technician or electrician making the test is required to interpret the pressure applied to the switch

when the continuity beeper sounds indicating contact closure of the switch. A workable solution but new tools can make this task easier.

Modern calibrators can automatically record the pressure applied when a pressure switch changes from open to closed and from closed to open. In doing so the switch set point and reset point and deadband are much easier to determine.

Suggested test tools



Fluke 754
Documenting
Process
Calibrator-HART
See pg 5



Fluke 750P Series
Pressure Modules
See pg 12



Fluke 700PTP-1
Pneumatic
Test Pump
See pg 23



Fluke 71X Hose Kit
Accessory

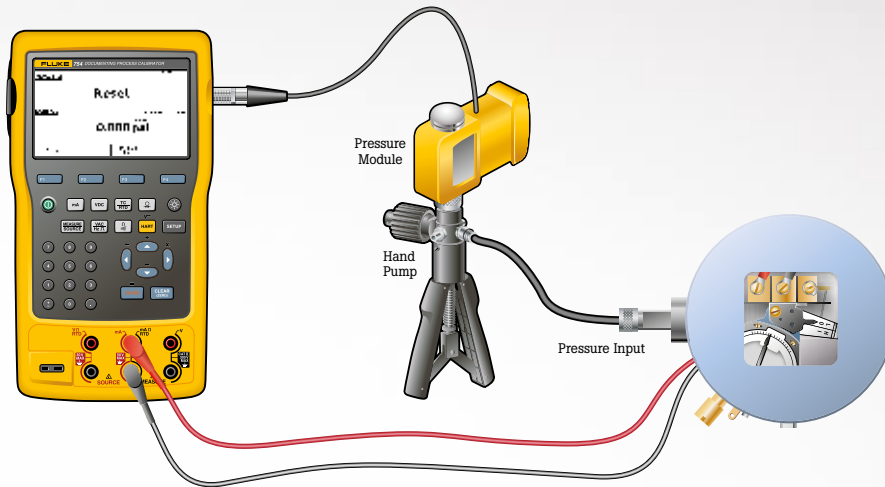

TECH TIPS

- The key to a good switch test is repeatability. Repeatability is best achieved by applying a slow change in pressure to the switch as it approaches its set or reset pressure.
- When performing the test find out where the switch sets and make sure the vernier/fine adjustment of your test pump has enough adjustment to vary the pressure up to the set point. In this way the pressure can be changed slowly capturing an accurate switch set point pressure. Repeat this procedure for the reset point.
- With practice you can get the vernier of the pump within range of the set and reset point pressure and get excellent repeatability of your tests (within the limitations of the switch being tested).

To perform the test:

With a modern documenting calibrator you can test for dry contacts opening and closing on the switch or if you are using the Fluke 753 or 754 you can leave the switch connected to the live voltage and the calibrator will measure the changing AC voltage and interpret it as opening and closing of the switch.

One cautionary note: it is always safer to test a de-energized circuit, but this is not always possible. Also, do not measure AC voltages above 300 V ac as that is the maximum rating of the 75X family. 480 V ac 3-phase voltages must be de-energized and disconnected from the switch if testing with the 75X family.

STEP 1

To get started testing the switch, connect as shown above. In this example we will test dry contacts and continuity. To measure continuity for the test select resistance measurement. Then toggle to the source screen mode and select pressure to display the pressure generated by the hand pump and measured by the pressure module. Advance the calibrator mode to the split screen test mode.

STEP 2

The next step is to describe the switch and whether it is normally open or closed at ambient pressure. The relaxed state of the switch is the reset state. The set state is the condition of the switch it changes to with applied pressure or vacuum. In this example the switch is normally open and is expected to close when the pressure applied exceeds 10 psi. Next the allowable pressure variance of the switch set state and deadband size needs to be defined. In this example the ideal switch set value is 10 psi and is allowed +/- 1 psi of deviation. The allowable reset pressure is described in the deadband tolerance. In this instance the reset state must be more than 1 psi less than the found set pressure but not greater than 3 psi less than the found set pressure.

STEP 3

Once the test tolerances are fully defined start the test. Increase the pressure until the calibrator captures the set state pressure value. Then decrease the pressure until the reset pressure is found. Repeat increasing and decreasing the pressure across the switch looking for repeatability in your set and reset pressure measurements. Once satisfied with the result press done to get the pass/fail evaluation of the switch. If the switch fails the test adjustment or replacement of the switch may be required. If the switch is adjusted repeat the test to document the As-Left condition of the switch before putting back into service. The test result is now documented and ready for upload to calibration management software.

Gas custody transfer flow computer calibration



Gas custody transfer flow computers that calculate flow in pipelines by measuring the differential pressure across a flow restriction, such as an orifice plate or other differential pressure flow device, require special calibration to perform at optimum accuracy. Gas flow computers make three primary measurements to calculate flow: volumetric flow (difference in pressure across the orifice plate), static pressure in a pipeline and gas temperature. A calculation is performed using this data to determine the actual mass and volume of the gas flowing through the pipeline.

These calibrations can be made with three separate calibrators, a low pressure, high pressure and a temperature calibrator or use a multifunction calibration tool designed for this specific task.

An example of a calibrator purposed for this task is the Fluke 721 or 721Ex. It has two built-in pressure ranges and the ability to measure temperature. The most popular configuration is 16 psi/1 bar on the low pressure (P1) sensor side and 1500/100 bar or 3000 psi/200 bar on the high pressure (P2) sensor side. It measures temperature using a precision RTD accessory and can display all three measurements at once if desired.

Suggested test tools



Fluke 721
Precision Dual
Range Pressure
Calibrator
See pg 12



Fluke 700G
Precision Pressure
Gauge Calibrator
See pg 13



Fluke 754
Documenting
Process
Calibrator-HART
See pg 5



Fluke 750P Series
Pressure Modules
See pg 12

TECH TIPS 

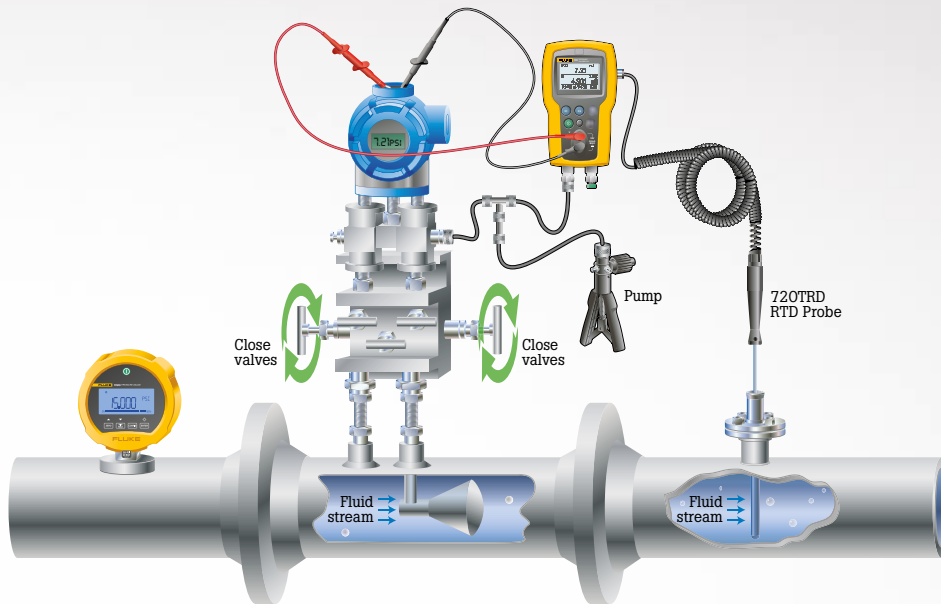

To perform the test:

To get started, isolate the flow computer from the pipeline. It is normally installed with a 5 valve manifold. If so, closing the valves on the pipeline side of the manifold should isolate it. Be sure to follow local policy and safety procedures when performing this isolation step. Set the P1 sensor of the 721 to measure inH2O and the P2 sensor to measure PSI and the temperature sensor to measure degrees Celsius or Fahrenheit as needed.

STEP 1

Low pressure differential pressure calibration is performed using atmospheric pressure as a low side reference. Vent the low connection of the flow computer or pressure transmitter and connect the high pressure connection of the flow computer or transmitter to the low pressure port (P1) on the calibrator.

Connect the computer (PC) to the flow computer serial or USB port. The PC will instruct the user to apply one or more test pressures to the flow computer or transmitter. For example, 0, 100 and 200 inH2O. Squeeze the pump to get close to the test pressure and use the vernier or fine pressure adjust to dial in.

STEP 2

Static pressure calibration will normally be applied to either the same high pressure port of the flow computer or both the high and low pressure ports. Refer to the manufacturer's instructions for details. Connect the high pressure sensor input (P2) to the appropriate port on the flow computer or transmitter and to the high pressure test source. The PC will instruct the pressures for the user to apply from the pressure source.

STEP 3

Temperature calibration of the temperature measurement on the flow computer is done with a single temperature point at the pipeline operating temperature. Insert the RTD probe into the test thermowell and allow time for the measurement to stabilize.

The PC will prompt the user to enter the temperature measured by the calibrator. Remove the RTD from the test thermowell and the calibration is complete.

STEP 4

Flow Computers with 4 to 20 mA inputs: Many flow computers utilize a low pressure, static and temperature transmitter to convert the measured parameters into 4 to 20 mA signals. In this instance these transmitters may need individual calibration if the test results are not satisfactory (see HART Transmitter Calibration application note or video for more details). Another source for errors in this configuration is the input A/D cards of the flow computer. These can be independently tested using a mA signal source from a loop calibrator.

- Always center the vernier of your hand pump before starting any pressure calibration. This will allow you to increase or decrease the pressure when making fine adjustments.
- Store the temperature probe in a protective case such as the built in slot of the 721 soft case. Exposing the RTD probe to mechanical stress can reduce the measurement accuracy of the probe.
- **Be careful to not connect the P1 low pressure side of the calibrator when doing high pressure calibrations or measurement or the sensor will be damaged and possibly rupture creating a dangerous condition.**
- Inserting the RTD probe prior to the pressure calibrations typically allows sufficient time to reach a stable temperature measurement.

Verifying process gauges, analog and digital



Both analog and digital process gauges need to be verified to detect errors related to drift, environment, electrical supply, addition of components to the output loop, and other process changes. Pressure gauges may be verified in the field or at the bench. Field calibration may save time, and allows for troubleshooting in the process environment. Multifunction calibrators make it easier to do this with one tool, and documenting calibrators make it easier to follow procedures, capture data and document results. Bench calibration provides an environment where the gauge can be cleaned, inspected, tested, and recertified under reference conditions for the best possible accuracy.

Suggested test tools



Traditional and
Electronic Dead-
weight Testers
See pg 14-15

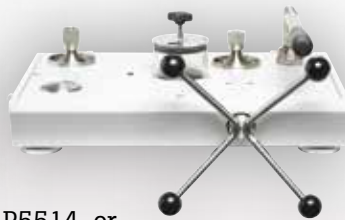

P5514, or
P5515
Hydraulic Pressure
Comparator
See pg 13



2700G Series
Reference Pressure
Gauges
See pg 13



Fluke 3130
Portable Pressure
Calibrator
See pg 14

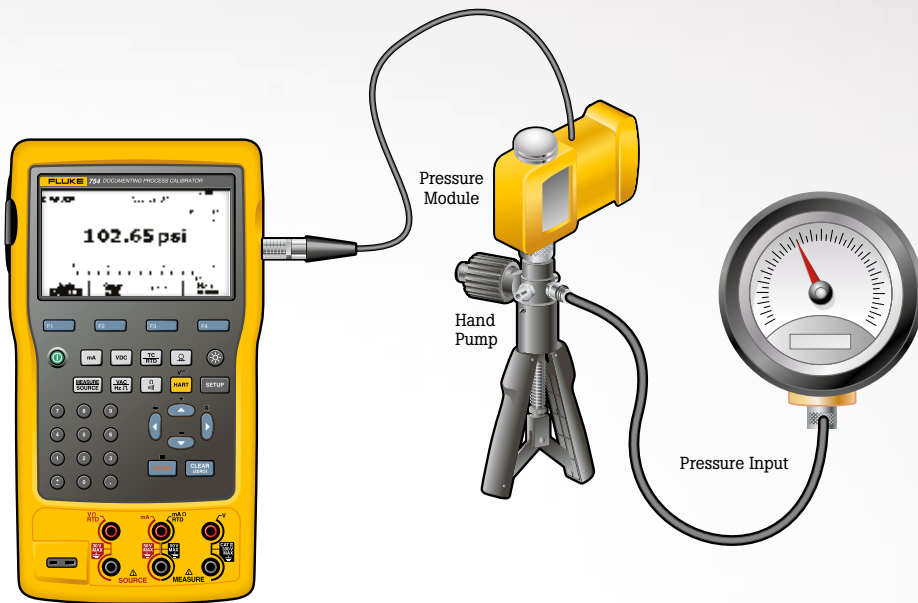

TECH TIPS

- Safety First! Check all fittings, adapters and connecting tubing ratings for pressures used.
- Remember to tap analog gauges at each point due to friction in mechanical parts.
- Gas is preferred for cleanliness requirements but use caution when generating pressures above 2,000 psi.
- Industry standards usually desire calibration equipment to be 4-10 times more accurate than the device under test.
- When in the field, connect pressure gauges through a manifold or “tee” connector.
- Use adapter fittings when workloads require calibrating a wide variety of gauges.
- Consider first, the in-use orientation of a device and use an angle adapter at the bench to achieve similar orientation.
- Use a liquid-to-liquid separator to prevent contamination in hydraulic applications.

To perform the test:

- STEP 1** Isolate the pressure gauge from the process using valves, or by removing the gauge from the process.
- STEP 2** Connect the gauge to the calibrator or reference gauge. For hydraulic pressure gauges it's important to remove any gas that might be trapped in the fluid in the gauge, calibrator, and connections by priming the system. When generating pressure allow a few moments for stability. Compare the reading of the gauge under test with the master gauge or calibrator.
- STEP 3** For hydraulic pressure gauges it's important prime the system. This will remove any gas that might be trapped in the fluid in the gauge, calibrator or connections.
- STEP 4** When generating pressure allow a few moments for the measurement to stabilize. When using a hydraulic hand pump as a source it can take several minutes for the pressure to stabilize due to the thermodynamic effect of fluids.
- STEP 5** Compare the reading of the gauge under test with the master gauge or calibrator.

Calibrating at the bench with a deadweight tester



A deadweight tester is a proven method of pressure calibration that is usually chosen for bench applications when accuracy and reliability are the top requirements. Calibrations are performed at the bench for convenience and to maintain reference conditions. The bench is a convenient location to clean, inspect, calibrate and repair with all the necessary equipment available. Reference conditions are necessary to achieve the reference accuracy of the device under test and the calibration standards. Reference accuracy may be required to maintain the necessary test uncertainty ratios (TUR).

Suggested test tools

Using liquid:



P3100, P3200, or P3800 Series Hydraulic Deadweight Tester

See pg 15



6531, 6532 Electronic Deadweight Tester

See pg 15

Using gas:



P3000 Series Pneumatic Deadweight Tester

See pg 14

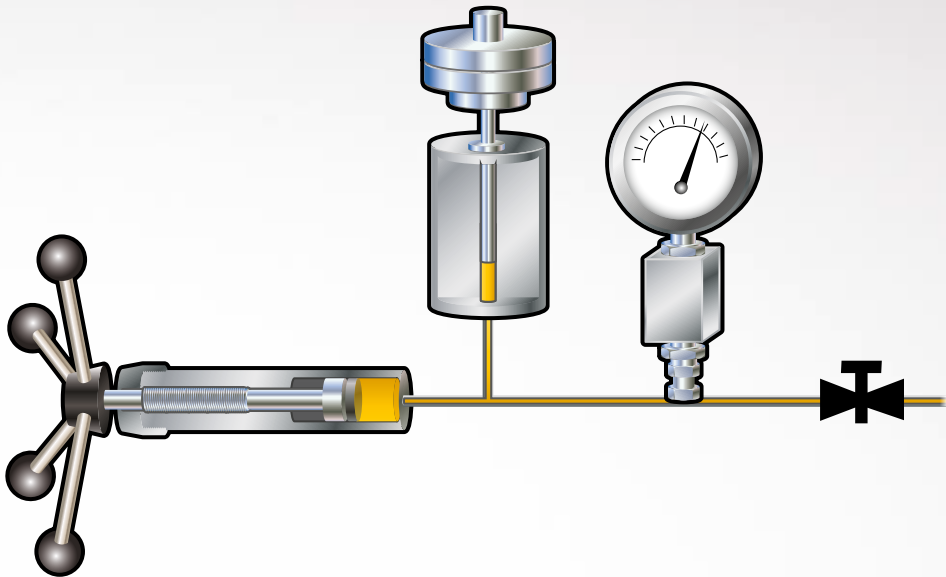

TECH TIPS

To perform the test:

- STEP 1** The pressure gauge should be mounted in the same orientation (vertical or horizontal) as in the process.
- STEP 2** Measurement points should be distributed uniformly over the calibration range.
- STEP 3** Calibrated weights are placed on the instrument corresponding to the measurement points.
- STEP 4** Pressure is added with an internal pump or screw press until the piston holding the weights begins to float.
- STEP 5** The piston and weight are spun by hand to minimize friction.
- STEP 6** While the piston is floating the reading on the device under test is compared to the pressure corresponding to the sum of the selected weights.

- Deadweight tester weights are calibrated to match a wide range of pressure units.
- Local gravity often is the largest factor affecting accuracy. Use Fluke PRESSCAL software to achieve accuracy of $\pm 0.008\%$.
- To increase the number of available set points, use incremental weight sets.
- Forgo wrenches or PTFE tape by using adapters to fit multiple sizes and types of devices with leak tight seals to 20,000 psi.
- Safety First! Choose fittings, tubing and seals with pressure ratings above the full scale of the instrument.
- Hydraulic systems are preferable to gas systems for pressures above 2000 psi due to safety and ease of use.
- Consider achieving cleanliness using distilled water as a media or use a liquid separator from Fluke instead of gas.
- Lubrication can improve performance by using oil when it is allowed.

Calibrating at the bench with a pressure comparator



A pressure comparator is a convenient instrument for bench pressure calibration. Bench calibrations are performed to maintain reference conditions and to obtain the lowest possible uncertainties. The bench is also a convenient place to inspect, adjust, and repair the devices under test.

Suggested test tools

Using liquid:

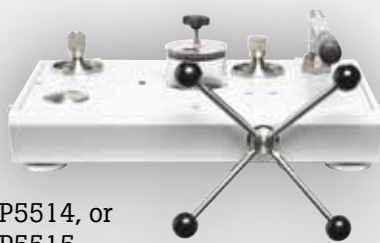

P5514, or
P5515
Hydraulic Pressure
Comparator
See pg 13

Using gas:



P5510, or P5513
Gas Pressure Comparator
See pg 12



2700G Series
Reference Pressure Gauges
See pg 13

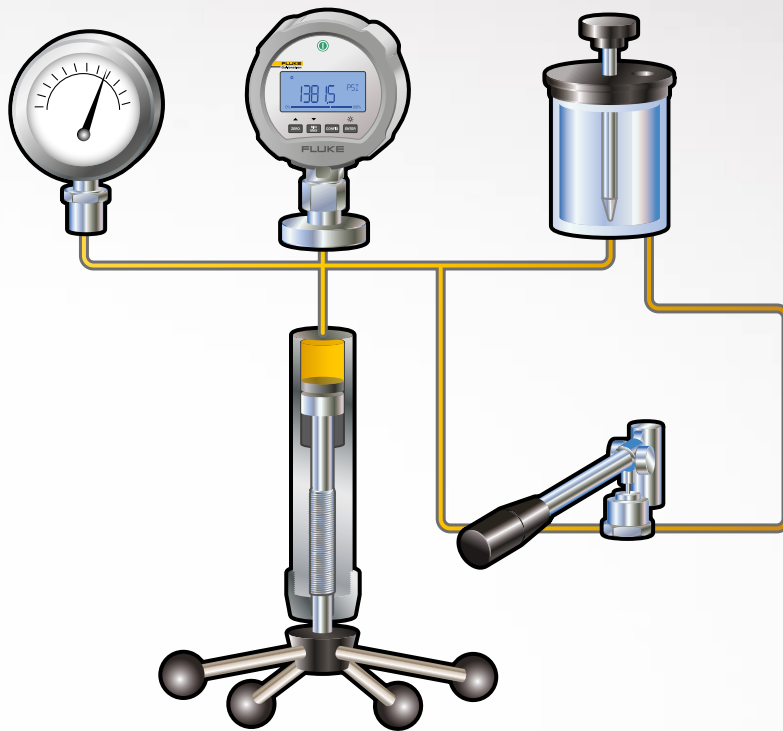

TECH TIPS

- Use a reference gauge with better accuracy to meet test uncertainty ratios over a wider range of pressures.
- Forgo wrenches or PTFE tape by using adapters to fit multiple sizes and types of devices with leak tight seals to 20,000 psi.
- Safety first! Always use fittings, tubing, and seals with pressure ratings above full scale of the instrument.
- If possible use oil for better lubrication.
- Use gas to improve cleanliness or a liquid-to-liquid separator available from Fluke.
- Hydraulic systems are preferable to gas systems for pressures above 2000 psi due to safety and ease of use.

To perform the test:

- STEP 1** The pressure gauge should be mounted in the same orientation (vertical or horizontal) as in the process. An angle adapter such as the P5543 may be used.
- STEP 2** The reference pressure gauge (2700G) should be mounted such that the display is easily seen.
- STEP 3** For hydraulic comparators prime the fluid with the priming pump, to remove any bubbles.
- STEP 4** Measurement points should be distributed uniformly over the calibration range. Conveniently source pressure with a manual pump up to 300 psi, after that use an external pressure supply.
- STEP 5** For gas comparators use the fine needle valve or fine adjustment screw press to precisely meter the pressure.
- STEP 6** With hydraulic models use the screw press to source and fine adjust the pressure.
- STEP 7** The source pressure can be adjusted until the device under test is reading a nominal pressure or until the reference gauge reads the nominal pressure.

Use and selection of hand pumps and pressure test gauges for field pressure testing



It's important to select the proper pump and gauge to match the testing application at hand—a good guideline is the testing device should be 4-10 times more accurate than the device being tested. To achieve this, match the measurement to be made as closely to the full scale value of the test gauge. This delivers the best accuracy from the gauge.

Suggested test tools



Fluke 700G
Precision Pressure
Gauge Calibrator
See pg 13



Fluke 700TPK2
Pneumatic Test
Pressure Kit



Fluke 700HTPK2
Hydraulic Test
Pressure Kit



Fluke 700TTH 10K
Transmitter Test Hose

To perform the test:

- STEP 1** The pressure gauge should be mounted in the same orientation (vertical or horizontal) as in the process.
- STEP 2** The reference pressure gauge (2700G) should be mounted vertically.
- STEP 3** For hydraulic comparators prime the fluid with the priming pump, to remove any bubbles.
- STEP 4** Measurement points should be distributed uniformly over the calibration range. Conveniently source pressure with a manual pump up to 300 psi, after that use an external pressure supply.
- STEP 5** For gas comparators use the fine needle valve or fine adjustment screw press to precisely meter the pressure.
- STEP 6** With hydraulic models use the screw press to source and fine adjust the pressure.
- STEP 7** The source pressure can be adjusted until the device under test is reading a nominal pressure or until the reference gauge reads the nominal pressure.

TECH TIPS

- The key to a good experience in using a hand pump, either pneumatic or hydraulic, is to test and debug your test setup in the shop before going to the field. Minimizing the number of pressure connections minimizes the probability for leaks. Mount the test gauge carefully to the test pump in the shop.
- Be sure to consider the hoses that connect from the hand pump to the device to be tested. There are a variety of specialty “no tools required” connectors to connect to the test hose to make this easy. If these connectors are not available be sure to have a variety of adapters, wrenches and PTFE sealing tape to be able to connect from the test hose to the input port of the device for testing. If using “push fit” hoses it is likely they will eventually leak. Each time - a push fit hose is connected, it leaves a mark on the test hose and eventually does not seal well. To eliminate the leak cut off the affected portion of the test hose so there is a clean surface to connect to. This process will need to be repeated with use.
- When attempting to get maximum pressure out of a pneumatic pump, adjust the fine adjust vernier all the way to down to the stop so turning the vernier increases the pressure. When approaching the target pressure use the vernier to increase to your target pressure.
- When using hydraulic hand pumps remember the thermodynamic effect. Once any fluid is compressed, the temperature increases and the fluid expands. This becomes obvious when pumping to a target pressure with a hydraulic pump. Once the target pressure is met the fluid has expanded. As the fluid cools and contracts the pressure quickly bleeds down until it reaches temperature equilibrium, this can take 5 minutes or more. Once the temperature stops changing, dial the desired pressure back in with the vernier adjuster.

Temperature Applications



INTRODUCTION

Temperature devices in process manufacturing environments provide measurements to the process plants' control systems. The performance of these temperature instruments is often critical to optimized operation of the process manufacturing plant or proper functioning of the plant's safety systems.

Process temperature instruments are often installed in harsh operating environments, causing their performance and the performance of their sensors to shift or change over time. Keeping these devices measuring temperature within expected limits requires periodic verification, maintenance and adjustments.

APPLICATION SELECTION GUIDE

									
Model number	75X	72X	712B/ 714B	1551A/ 1552A	1523/ 1524	914X	7526A	418X	1586A
Application									
Calibrate and test RTD sensors	■*	■*	*712B	*	*	Ideal	■*		■*
Calibrate and test thermocouple sensors	■*		*714B	*	*	Ideal	*		■*
Simulate RTDs		■	712B				■		
Simulate thermocouples		■	714B				■		
Generate precision temperatures						■			
Documenting temperature transmitter calibrations	Ideal								
Temperature transmitter calibration with sensor	■*					■			
Calibrating HART smart temperature transmitters	Ideal								
Temperature switch/controller testing and calibration	Ideal	726				■	■		
Temperature switch/controller testing live contacts	Ideal								
Infrared thermometer test and calibration								Ideal	
Verifying process temperature gauges				■	■	■			■
Logging temperature measurements	■			1552A	Ideal				■
Precision temperature measurement				■	Ideal				
Automated batch testing of temperature sensors**						Ideal			Ideal

* Requires a dry-well such as 914X or 910X

** Requires both a dry-well and a 1586A

Calibrating and testing RTD sensors



Typically RTDs are checked while calibrating the connected device, such as a panel meter or temperature transmitter. However, if a problem is suspected with a temperature sensor, sensor calibrations can be performed separately from the calibration of process electronics.

Field checks of temperature sensors can be easily performed with a dry-block or Micro-Bath. For best results, a full calibration of a temperature sensor is performed at the bench.

Suggested test tools



9144 Field Metrology Well and 5615 Secondary Reference Temperature Standard
See pg 17



9102S Handheld Dry-Well
See pg 18



9100S Handheld Dry-Well
See pg 18



9009 Industrial Dual-Block Thermometer Calibrator
See pg 18



726 Precision Multifunction Process Calibrator
See pg 6



6102 Micro-Bath Thermometer Calibrator and 1523-P1 Reference Thermometer
See pg 19 and 20

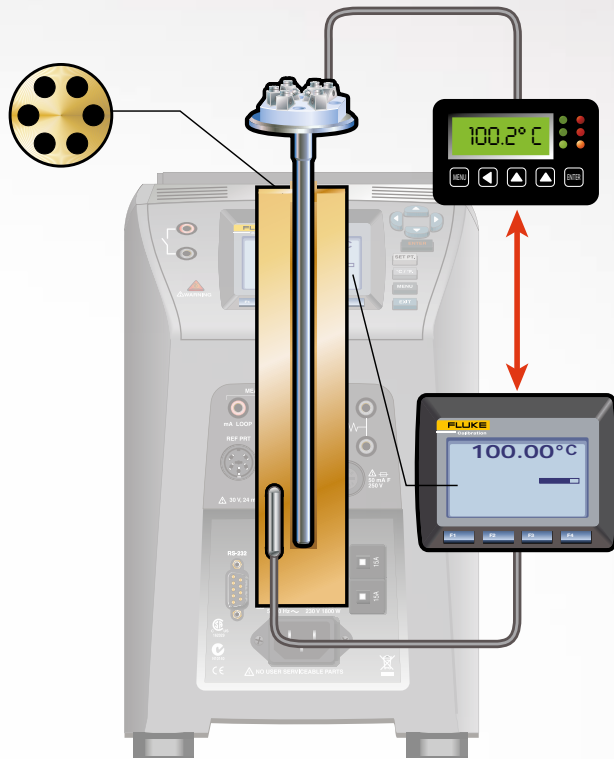

TECH TIPS

- Dry-wells have inserts that are interchangeable and have a variety of hole patterns to accommodate various probe sizes.
- To achieve published performance levels, the insert's hole size should be no more than a few hundredths of an inch larger than the probe being calibrated.
- Avoid placing fluids in a dry-well. If fluids are required, use a Micro-Bath instead.
- If climbing a ladder is required, dry-wells are safer than baths, and handheld dry-wells may be the most convenient.

To perform the test:

- STEP 1** Isolate the sensor from the process.
- STEP 2** Fully immerse the sensor into a precision temperature source, such as a dry-well or bath capable of covering the required temperature range.
- STEP 3** For best accuracy, also fully immerse a temperature standard into the dry-well or bath for comparison (the process version of Field Metrology Wells have a built-in precision readout for the temperature standard).
- STEP 4** To check the calibration of the RTD separately from the control system temperature indicator, disconnect the RTD from the electronics.
- STEP 5** Connect the RTD to a precision instrument capable of measuring resistance. (The process version of Field Metrology Wells have the required electronics built in.)
- STEP 6** Adjust the temperature of the bath or dry-well to each of the test points (With Field Metrology Wells these test points can be preprogrammed and automated.)
- STEP 7** At each test point record the readings of the temperature standard and RTD.
- STEP 8** If measuring the RTD separate from its measurement electronics, compare the measured resistances to the expected resistance from the applicable temperature table. Otherwise, compare the reading on the instrument display to the reading of the temperature standard (which may be the dry-well).

Calibrating and testing thermocouple sensors



Thermocouples are common in industry because they are inexpensive and cover a wide temperature range.

They should be tested during commissioning and again when removed from a process to verify that tolerances were met. Additionally, thermocouples may be tested at regular calibration intervals and when suspected of failing to meet their performance specifications.

Often thermocouples need to be calibrated prior to use for mapping a temperature controlled enclosure, or they have to be calibrated for use as a temperature standard.

Due to the unique characteristics of thermocouples, they are best calibrated in situ (in place) by comparison to a temperature standard. However, in situations where that is not practical, it is necessary to remove the thermocouple and place it in a precision temperature source such as a dry-well.

Suggested test tools



9144 Field Metrology Well
See pg 17



9100S Handheld Dry-Well
See pg 17



9150 Thermocouple Furnace
See pg 19



6102 Micro-Bath Thermometer Calibrator
See pg 19

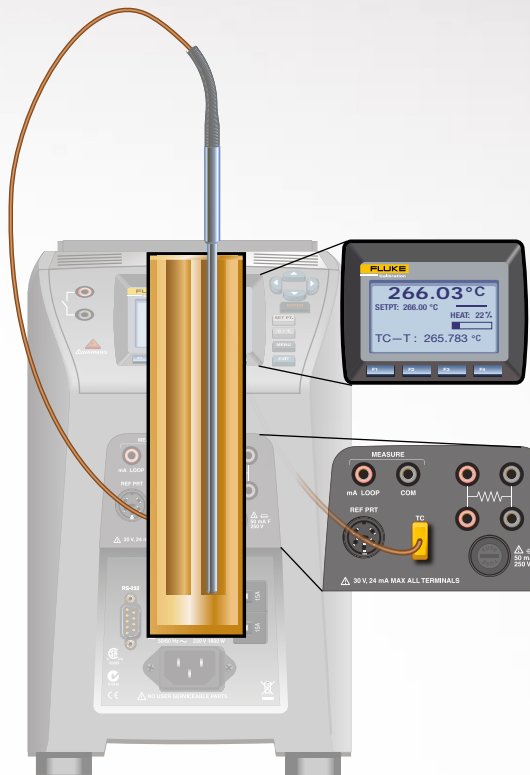

TECH TIPS

- Depending on the thermocouple, incorrectly setting reference junction compensation may result in a temperature error of around 23 °C. Also, the reference junction compensation accuracy of the meter may be the largest contributor to the error.
- Thermocouple wire generates a voltage whenever two adjacent points along the wire are at different temperatures.
- The whole length of the wire (not just the probe tip) generates the voltage. This means the whole wire needs to be treated carefully and considered during the calibration.

To perform the test:

- STEP 1** Isolate the sensor from the process.
- STEP 2** Fully immerse the sensor into a precision temperature source such as a dry-well or bath capable of covering the required temperature range.
- STEP 3** To check the calibration of the thermocouple separately from control system temperature indicator, disconnect the thermocouple from the electronics.
- STEP 4** Connect the thermocouple to a precision instrument capable of measuring millivolts. (The process version of Field Metrology Wells have the required electronics built in.)
- STEP 5** If the thermocouple has a reference junction (most do not), then ensure that the reference junction is also immersed at the required reference temperature. Usually, this is 0 °C.
- STEP 6** Typically, the thermocouple will not have a reference junction. In that case, ensure that the precision voltage measurement device has reference junction compensation (may be identified as RJC or CJC) turned on.
- STEP 7** Adjust the temperature of the bath or dry-well to each of the test points. (With Field Metrology Wells these test points can be preprogrammed and automated.)
- STEP 8** At each test point record the readings of the temperature standard and thermocouple.
- STEP 9** If measuring the thermocouple separate from its measurement electronics, compare the measured voltage to the expected voltage from the applicable temperature table. Otherwise, compare the reading on the instrument display to the reading of the temperature standard (which may be the dry-well).

Simulating thermocouples and RTDs for calibration and testing



Thermocouples and RTDs are the most common sensors used in process temperature measurements.

Simulating a process sensor signal into a process instrument or control system input enables a technician to verify whether the device responds correctly to the temperature measured by the instrument. There are many different ways to simulate these sensors for testing purposes.

You can use a mV dc source and a mV vs temperature look up table (below on the left), for simulating thermocouples or a resistance decade box and resistance vs temperature look up table (below on the right), for simulating RTDs. This method, however, has become outdated with modern temperature calibrators that do the conversion for the user. With modern calibrators, simply select the sensor type to simulate, input the temperature to source and connect to the devices under test.

Thermocouple Table – Temperature vs mV

°C	0	1	2	3
0	0.000	0.039	0.079	0.119
10	0.397	0.437	0.477	0.517
20	0.796	0.838	0.879	0.919
30	1.203	1.244	1.285	1.326
40	1.612	1.653	1.694	1.735
50	2.023	2.064	2.106	2.147
60	2.436	2.478	2.519	2.561
70	2.851	2.893	2.934	2.976
80	3.267	3.308	3.350	3.391
90	3.682	3.723	3.765	3.806
100	4.096	4.136	4.179	4.220

RTD Table – Temperature vs Resistance

°C	Ohm	Diff.	°C	Ohm	Diff.	°C	Ohm	Diff.
0	100.00	0.39	10	103.90	0.39	20	107.79	0.39
1	100.39	0.39	11	104.29	0.39	21	108.18	0.39
2	100.78	0.39	12	104.68	0.39	22	108.57	0.39
3	101.17	0.39	13	105.07	0.39	23	108.96	0.39
4	101.56	0.39	14	105.46	0.39	24	109.35	0.39
5	101.95	0.39	15	105.85	0.39	25	109.73	0.39
6	102.34	0.39	16	106.24	0.39	26	110.12	0.39
7	102.73	0.39	17	106.63	0.39	27	110.51	0.39
8	103.12	0.39	18	107.02	0.39	28	110.90	0.39
9	103.51	0.39	19	107.40	0.38	29	111.28	0.38

Suggested test tools



712B RTD Temperature Calibrator
See pg 17



714B Thermocouple Temperature Calibrator
See pg 17



7526A Precision Process Calibrator
See pg 5



726 Precision Multifunction Process Calibrator
See pg 6



754 Documenting Process Calibrator
See pg 5

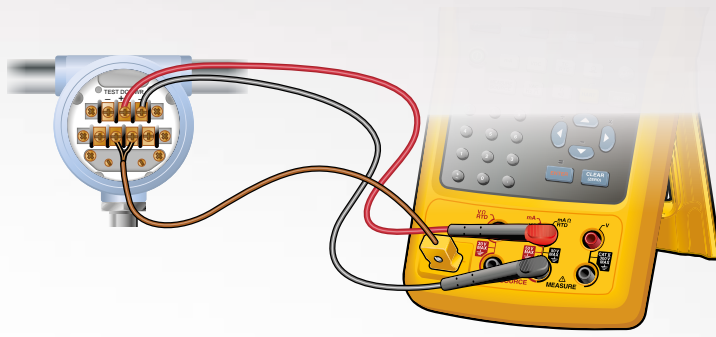

TC transmitter calibration connection

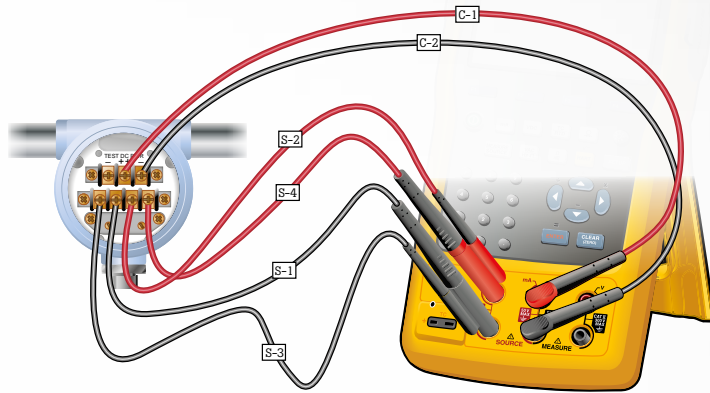

RTD transmitter calibration connection

TECH TIPS

- When simulating a thermocouple signal from a simulator, always use the correct thermocouple wire for the test, either the exact same TC wire type or a compatible extension wire type.
- When simulating temperature using a calibrator with active reference junction compensation, remember the calibrator actively compensates for temperature changes. Changes in ambient temperature should be compensated for automatically.
- When testing 3-wire RTD circuits make sure to connect all three wires from the sourcing RTD simulator to the device being tested. Shorting out the compensation wire at the transmitter defeats the lead compensation circuit and introduces measurement errors.

To perform the test:

To use a thermocouple simulator to test a device with a thermocouple input:

- STEP 1** Disconnect the process measurement sensor and connect the test connection wires in its place (Figure A).
- STEP 2** Connect the mini-connector from the test wires to the TC source connection of the calibrator.
- STEP 3** Connect a DMM or other measurement tool to the tested device's mA output.
- STEP 4** Verify the devices range or span. Apply the 0% value with the simulator and verify with the DMM that the output mA value or voltage is as expected.
- STEP 5** Repeat the test, applying the 50% and 100% temperature signals.
- STEP 6** If the measured output of the device is within limits, the test is complete. If not, adjust the device at zero (offset, 0%) and span (gain, 100%).
- STEP 7** Repeat steps 4 and 5 and verify for a correct response.

To use an RTD simulator to test a device with an RTD input:

- STEP 1** Connect the calibrator to the device input as shown in figure B.
- STEP 2** Connect the calibrator output with the right combination to match the device configuration (2, 3 or 4-wire).
- STEP 3** Use the test procedure at left for thermocouple testing, starting at step 3.

Using a precision thermometer for single point process temperature verification



It's not always possible or practical to remove instruments from a process for calibration. In situ verification at a single point may be the only way to know whether an instrument is performing as expected. A single point verification is most effective over a narrow temperature range and when combined with other trends and information related to the process and equipment. It also requires the process not to be in a dynamic state of change.

In a single point process temperature verification, a temperature standard such as a reference PRT connected to a readout such as a 1523A is placed in thermal equilibrium with the sensor of the instrument to be verified without removing it from the process. Usually this is accomplished with a test well that is installed in a location adjacent to the sensor to be tested.

The reading from the temperature standard is compared to the reading on the panel meter, controller, or transmitter to determine the error and prove the tolerance condition of the loop.

Suggested test tools



1523-P1
Reference
Thermometer
See pg 20



1524-P1
Reference
Thermometer
See pg 20



1551A Ex "Stik"
Thermometer
Readout
See pg 20



1552A Ex "Stik"
Thermometer
Readout
See pg 20



TECH TIPS

- For this type of application a battery powered digital thermometer is usually preferred.
- A graphing display helps the technician visualize trends such as stability quickly and easily.
- Ensure that both the probe and the readout of your temperature standard have traceable calibration certificates from a competent laboratory.
- If the probe and readout separate from each other, smart connectors, which include probe calibration constants, provide a best practice method of ensuring that the readout is using the correct probe calibration in its temperature readings.

To perform the test:

- STEP 1** The test well (thermowell) should be within a few inches of the temperature transmitter and sensor assembly to be tested.
- STEP 2** Make sure that the probe of the temperature standard is long enough to reach the bottom of the test well and that air gaps between the probe and well are minimized.
- STEP 3** Wait for the temperature standard to reach the temperature of the test well. This will take a few minutes.
- STEP 4** Check for temperature stability. A graphing digital thermometer such as the 1524 makes stability easier to recognize.
- STEP 5** Record the reading from the measurement system and the temperature standard to determine whether the measurement system's readings are suspect.

Temperature switch and controller testing in the field



Temperature switches and controllers are commonly used in small processes and in control loops where a programmable logic controller (PLC) or larger distributed control system (DCS) are not warranted.

Temperature controllers provide both switching capability based on rising and dropping temperatures, as well as a local indication of the measured temperature.

Most temperature controllers have some form of tuning, using damping and PID (Proportional, Integral and Derivative values) for smoothing out the measured process temperature, reducing variability.

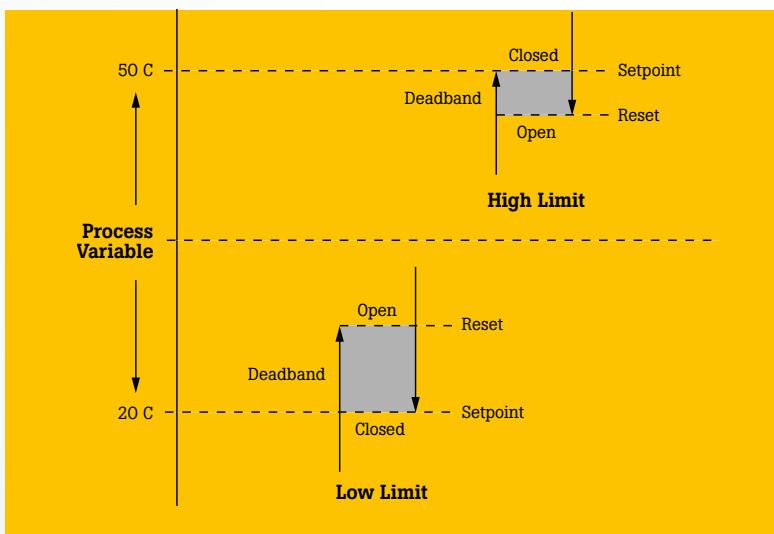

The terminology around switches can be confusing. The set state of the switch is the action the switch takes when an input stimulus above or below a specified value is applied. This stimulus can prompt an action such as closing a switch, which in turn starts or stops a motor, or opens and closes a valve. The reset point is considered the relaxed state of the switch, which is typically referred to as “Normally Open” or “Normally Closed.” This describes the default condition of the switch. Lastly, deadband is the band of temperature equal to the difference between the temperatures where a switch sets, and resets. See illustration at left.

Suggested test tools



712B RTD
Temperature
Calibrator
See pg 17



714B
Thermocouple
Temperature
Calibrator
See pg 17



7526A
Precision Process
Calibrator
See pg 5



726 Precision
Multifunction
Process
Calibrator
See pg 6



754
Documenting
Process
Calibrator
See pg 5

TECH TIPS

- When testing the temperature switch, the applied temperature should agree with the temperature displayed on the controller or switch's display. If it does not agree, the device's input A/D may need adjustment per manufacturer's procedure.
- When testing a switch with damping (delay of output change for a change on the input) set, it might be necessary to test the switch manually by slowly changing the temperature in small tests.
- When testing a mechanical temperature switch (no external sensor), use a field temperature bath calibrator for best results.
- To test live switch contacts switching 24 V dc or 120–240 V ac, select a calibrator that can measure these live voltages, such as the Fluke 75X family of Documenting Process Calibrators. Most other temperature calibrators can only measure continuity changes when testing switches.

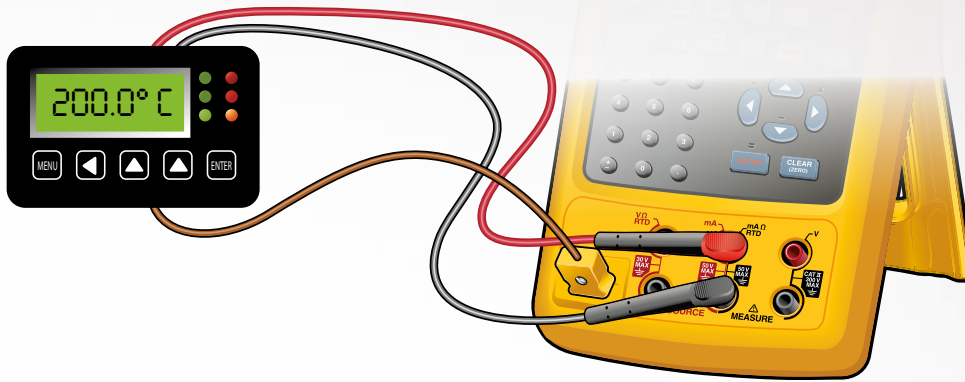

To perform the test:

To use a thermocouple simulator to test a switch with a thermocouple input:

- STEP 1** Disconnect the process measurement sensor.
- STEP 2** Connect the mini-connector from the test wires to the TC source connection of the calibrator (figure above).
- STEP 3** Connect the calibrator resistance measurement terminals to the switch contacts to measure continuity.
- STEP 4** Set the calibrator to source/simulate the correct thermocouple type and to measure resistance.
- STEP 5** Configure the calibrator for the switch test describing the expected setpoint temperature, allowable deviation and expected deadband values.
- STEP 6** Run the test and evaluate the test results.
- STEP 7** Adjust the switch as needed and repeat the test, confirming that the adjustment was successful and the switch is performing as expected.

Temperature switch and controller testing at the bench



A temperature switch is a device that protects a thermal system by sensing temperature and closing or opening a switch to shut down a process or equipment if the temperature is outside the safe range.

Temperature switches are often calibrated or tested for safety reasons to determine how accurate and repeatable the device is. The temperature at which a switch activates is called the set point and is an important value that needs to be verified during testing.

Another critical safety related value is called the deadband. Below the low end of the deadband, the heating system turns on. Above the high end of the deadband, the heating system turns off.

Switch tests may be operated manually or automatically. If the electronics are not built into the dry-well for a switch test, then a DMM will be needed to determine the open/close condition. Metrology Wells and most Field Metrology Wells have built-in routines to automate switch testing.

Suggested test tools



9142, 9143, 9144 Field Metrology Wells
See pg 17



6102 Micro-Bath
Thermometer Calibrator
See pg 19



7103 Micro-Bath
Thermometer Calibrator
See pg 19



6109A/7109A
Micro-Bath
See pg 19

TECH TIPS 

- Set the scan rate to a low value, i.e. 1.0 °C per minute, for better accuracy.
- If the scan rate is too low, the duration of the test may be longer than necessary.

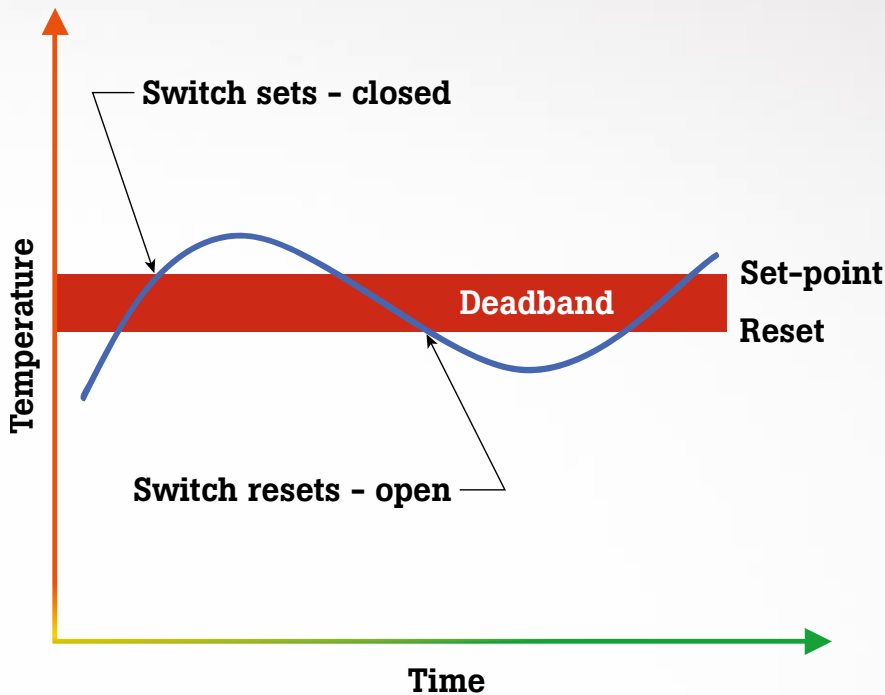

To perform the test:

- STEP 1** Isolate the switch from the process.
- STEP 2** Fully immerse the switch into a precision temperature source such as a dry-well or bath capable of covering the required temperature range.
- STEP 3** Connect the leads of the switch to a digital multimeter or to the switch test inputs of the dry-well.
- STEP 4** If using a Metrology Well or Field Metrology Well, increase the temperature to the set point. Continue raising the temperature until the switch changes state and record that temperature.
- STEP 5** Decrease the temperature until the switch resets (changes state again) and record the temperature.
- STEP 6** Repeat the process as many times as needed, but reduce the ramp rate and target the last measured set point and reset points to verify accuracy and repeatability.
- STEP 7** Record the deadband (difference between the set point and the reset point).

Calibrating with a micro-bath



Instrument technicians need to calibrate a wide variety of temperature sensors including liquid-in-glass thermometers, dial gauges, and sensors that come in odd shapes and sizes.

Problems of fit and immersion that may occur with short, square, or odd-shaped sensors are practically eliminated in a Micro-Bath because the probes are immersed in a fluid that is magnetically stirred for optimal stability.

Micro-Baths combine the portability of a dry-well with the stability and versatility of a calibration bath. They are lighter and smaller than most dry-wells and come with a spill-proof lid.

Suggested test tools



6109A/7109A
See pg 19



7103 Micro-Bath
Thermometer
Calibrator
See pg 19



7102 Micro-Bath
Thermometer
Calibrator
See pg 19



6102 Micro-Bath
Thermometer
Calibrator
See pg 19



1523-P1
Reference
Thermometer
See pg 20

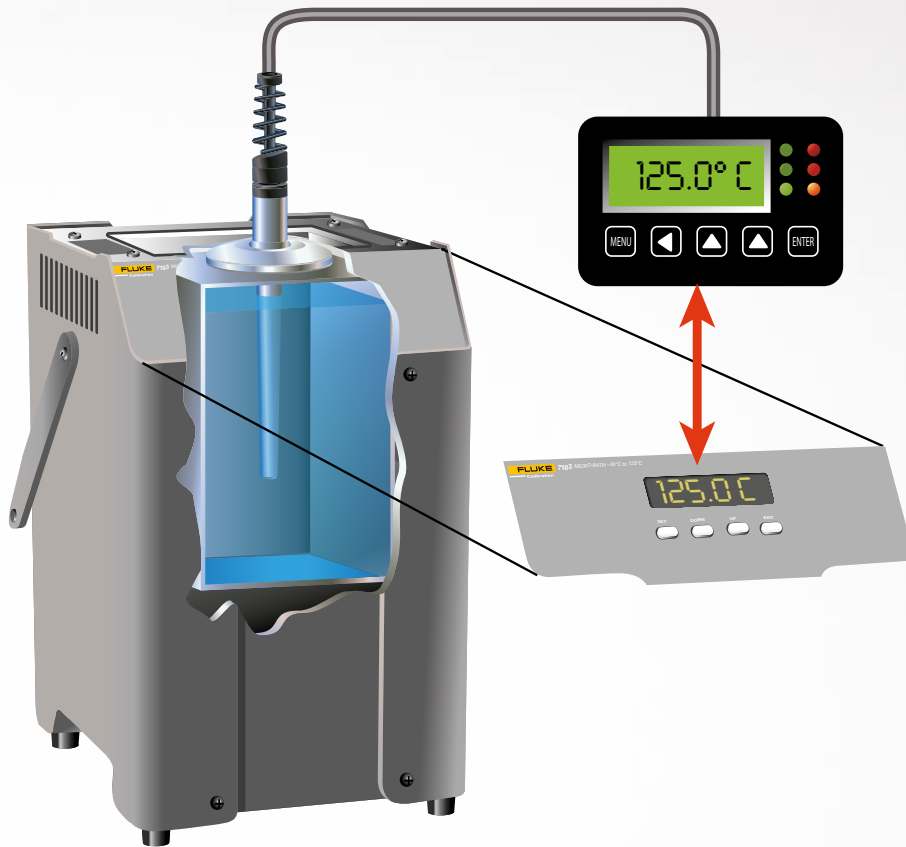

TECH TIPS

- **Caution:** the fluid level rises with higher temperatures and with the number and size of the probes placed into the fluid.
- Best results are obtained with the probe inserted to the full depth of the well.
- The stabilization time of the Micro-Bath depends on the conditions and temperatures involved. Typically stability is achieved within ten minutes.

To perform the test:

- STEP 1** Place the calibrator on a flat surface with at least six inches of free space around the instrument.
- STEP 2** Carefully insert the probe basket into the well and fill with the appropriate fluid.
- STEP 3** For optimal performance allow the manufacturer-recommended warm-up period.
- STEP 4** Insert the test probe to be calibrated into the well of the bath. For best performance, also insert a temperature standard for comparison.
- STEP 5** Once the probe is inserted to the full depth of the bath, allow adequate stabilization time for the test probe temperature to settle.
- STEP 6** Once the probes have settled to the temperature of the bath, their indication may be compared to the calibrator display temperature (or to a temperature standard such as a 1551A).

Infrared thermometer test and calibration



Infrared thermometer calibrations can be accurate with the proper setup and planning. It's important to choose a calibrator with a radiometrically calibrated target that is large enough to accommodate the recommended calibration distance of common infrared thermometers, along with their various fields of view.

Common errors include pressing the infrared calibrator too close to the hot surface of the calibrator or simply moving the infrared thermometer back and forth until the desired reading is achieved.

The manufacturer will have calibrated the infrared thermometer at a specific distance with a source that meets certain size requirements and has a specific emissivity (often but not always 0.95). To have a meaningful calibration that determines whether the instrument continues to operate within its design specifications, those conditions need to be reproduced as closely as possible.

Suggested test tools



4181 Precision
Infrared Calibrator
See pg 19



4180 Precision
Infrared Calibrator
See pg 19

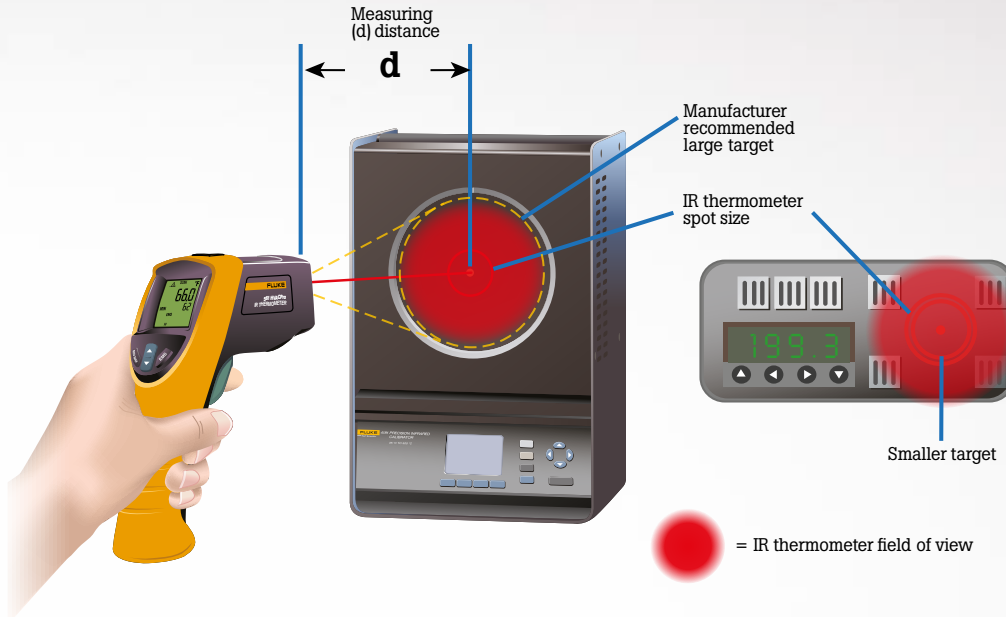

TECH TIPS

- Emissivity makes a big difference in infrared temperature measurement.
- The temperature and emissivity of the 4180 and 4181 are calibrated radiometrically for the most reliable and traceable results.
- The Fluke 4180 and 4181 can be set to match the emissivity setting of fixed emissivity thermometers.
- The large area of the 4180 and 4181 target allows infrared thermometers to be calibrated at the recommended distance without including unwanted surfaces in the field of view.
- Use a mounting device such as a tripod to maintain the calibration distance.
- Measure the calibration distance from the flat plate surface to the surface of the front housing of the infrared thermometer.

To perform the test:

- STEP 1** Allow at least 15 minutes for the IR thermometer to reach the temperature of the shop or laboratory.
- STEP 2** Set the radiation source to the desired calibration temperature. Depending on the temperature range a low, high, and midpoint temperature may be chosen.
- STEP 3** If the infrared thermometer has an emissivity setting, it should be set to match the calibrated emissivity of the source.
- STEP 4** Position the infrared thermometer at the manufacturer's recommended calibration distance.
- STEP 5** Center the infrared thermometer on the calibrator surface. Do this by adjusting the aim slightly side to side and up and down to maximize the signal.
- STEP 6** The measurement time should be ten times longer than the infrared thermometer's response time. This is typically five seconds for Fluke infrared thermometers.
- STEP 7** Record the calibrator indicated reading and the indicated reading of the thermometer under test to determine the error and tolerance status of the thermometer at each set point.
- STEP 8** Repeat for the other set point temperatures.

Loop calibration with a temperature transmitter at the bench



In industrial process industries, temperature measurement equipment usually has two components: a sensing device such as an RTD or thermocouple and a transmitter to read and relay the signal to the control system.

All sensors, including RTDs, drift with time. Thus, testing the transmitter and not the sensor could result in misjudgment regarding a system's performance. To avoid this potential problem, process instrument manufacturers recommend including the temperature sensor in loop calibration to prove the effectiveness of the entire system.

Suggested test tools



9142, 9143, 9144 Field Metrology Wells
See pg 17



7526A Precision Process Calibrator
with temperature source
See pg 5



754 Documenting
Process Calibrator with
temperature source
See pg 5

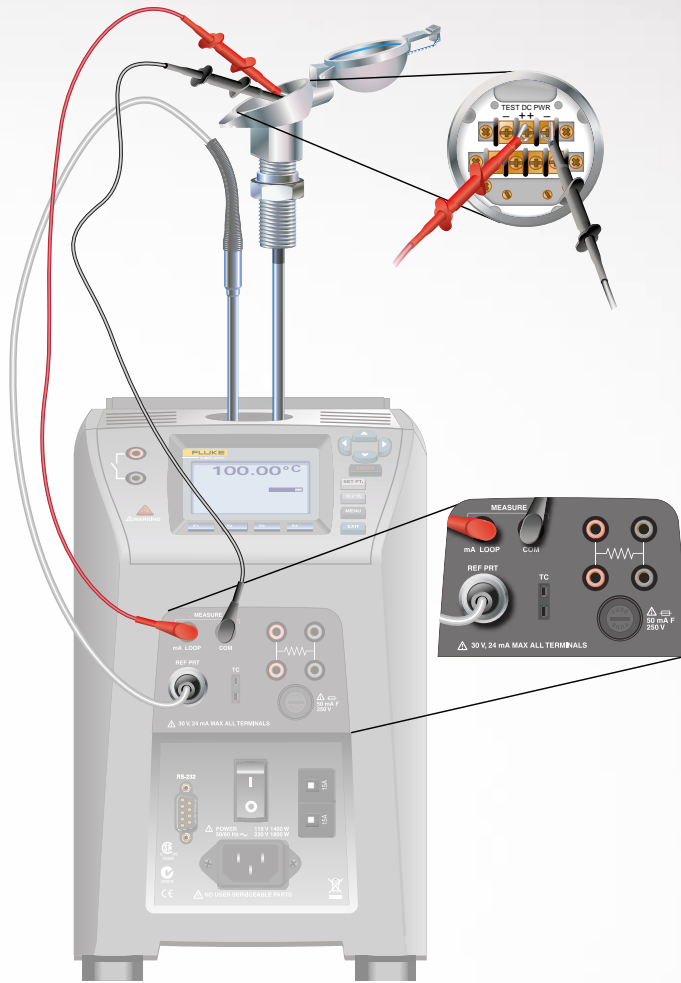

TECH TIPS

- Streamline the process with automation and provide documentation using a Fluke 754.
- Seventy-five percent of the errors in a temperature measurement system comes from the sensor.
- At minimum, you need a calibrator, and a device to measure 4–20 mA and power the loop.
- Choose a temperature standard with a 90 degree angle bend to ensure both the temperature standard and the transmitter fit in the dry-well at the same time.

To perform the test:

- STEP 1** Isolate the sensor from the process.
- STEP 2** Fully immerse the sensor into a precision temperature source such as a dry-well or bath capable of covering the required temperature range.
- STEP 3** Connect the temperature standard and 4–20 mA output of the transmitter to a suitable meter or calibrator (for example, the process electronics on a Fluke Field Metrology Well or the inputs of a Fluke 754).
- STEP 4** Power the loop. (The Fluke 754 and the process electronics in a Field Metrology Well have this capability.)
- STEP 5** Adjust the temperature of the bath or dry-well to each of the test points. (With Field Metrology Wells, these test points can be preprogrammed and automated.)
- STEP 6** At each test point, monitor and record the readings of the temperature standard and the local or remote readings connected to the transmitter output.
- STEP 7** Also, record the 4–20 mA output of the transmitter to determine which device needs adjustment if an adjustment is required.

FLUKE®

Calibration

Fluke Calibration products and services

Short form catalog

Precision, performance, confidence.™



Table of contents

2 Electrical calibration



DC/LF electrical calibrators	5
Specialty calibrators	6
Oscilloscope calibrators	7
Precision multimeters	7
Electrical standards	8

Featured products

5730A Multifunction Calibrator

Page 3

5322A Electrical Safety Tester Calibrator

Page 3

9 RF calibration



RF references	10
---------------------	----

Featured products

96270A 27 GHz Low Phase Noise Reference Source

Page 10

96040A Low Phase Noise Reference Source

Page 10

11 Temperature calibration



Standard platinum resistance thermometers	18
ITS-90 fixed-point cells	18
Cell maintenance apparatus	19
Thermometer readouts	20
Reference PRTs	21
Thermocouples	21
Thermistors	21
Compact calibration baths	22
Standard calibration baths	22
Special application baths	23
Bath controllers	23
Metrology Wells	23
Field Metrology Wells	23
Dual-block dry-well	24
Field dry-well calibrators	24
Micro-Baths	24
Portable Calibration Baths	24
Handheld calibrators	24
Infrared calibrators	25
Zero-point dry-well	25
Surface probe calibrator	25
Thermocouple furnaces	25

Featured products

6109A/7109A Portable Calibration Baths

Page 12

1586A Super-DAQ Precision Temperature Scanner

Page 12

26 Humidity calibration



Humidity calibrators 27

39 Gas flow calibration



Gas Flow Standards..... 40

28 Pressure calibration



Gas pressure controllers/calibrators 32
 High pressure controllers/calibrators 33
 Reference pressure indicators..... 33
 PG7000 series piston gauges..... 32
 2400 series piston gauges..... 34
 Specialty piston gauges 35
 Manual pressure generation and control..... 35
 Industrial deadweight testers 36
 Pressure comparators 36
 Pressure calibrators 37
 Air data calibration..... 38
 Pressure calibration systems 38

Featured products

8270A/8370A Modular Pressure Controllers/Calibrators

Page 29

6270A Modular Pressure Controller/Calibrator

Page 29

2271A Industrial Pressure Calibrator

Page 29

41 Calibration software



Electrical and RF calibration software..... 43
 Calibration asset management software 43
 Software support programs..... 43
 Temperature calibration software..... 44
 Pressure/Flow calibration software..... 45

Featured products

MET/TEAM® Test Equipment Asset Management Software

Page 42

MET/CAL® Calibrator Management Software

Page 42

46 Data acquisition and general purpose test



Featured products

2638A Hydra Series III Data Acquisition System

Page 47

Fluke DAQ 6.0 Application Software

Page 47

Service programs..... 50

Training..... 51



Electrical calibration

Electrical calibration refers to the process of verifying the performance of, or adjusting, any instrument that measures, sources, or tests electrical parameters. This discipline is usually referred to as dc and low frequency ac electrical metrology. Principal parameters include voltage, current, resistance, inductance, capacitance, time and frequency. Other parameters, including electrical power and phase, are also in this segment of metrology. Ratiometric comparisons of similar parameters are often performed to compare a known parameter to an unknown similar parameter.

Electrical calibration involves the use of precise devices that evaluate the performance of key

properties for other devices called units under test (UUTs). Because these precise devices have thoroughly known performance characteristics compared to the UUT, performance evaluation and/or calibration adjustment of the UUT to identify or minimize errors is possible. Typically, the performance of such precision devices should be four or more times better than the UUT.

These precision devices fall into two broad categories. Electrical signal sources are often referred to as either calibrators or standards. Precision measurement devices are often classified as reference digital multimeters, measurement standards, or ratio bridges.

Product highlights



5730A Multifunction Calibrator

The new gold standard in electrical calibration

The 5730A High Performance Multifunction Calibrator is the culmination of years of engineering development, customer research and industrial design, to bring to market the new gold standard in multifunction calibration. Like its predecessors, the 5700A and 5720A calibrators, the 5730A calibrates a wide range of digital multimeters, up to long-scale 8.5 digit DMMs, as well as a wide-range RF multimeters. This new model features improved specifications that will help you increase test uncertainty ratios (TURs) and improve test confidence.

- 6.5 inch VGA capacitive touchscreen with full color graphical user interface
- Menus and functions displayed in choice of nine languages
- Visual Connection Management™ terminals guide cable connections
- Extended operational reliability through the use of modern analog and digital components and state-of-the-art circuit board technologies
- Artifact Calibration—the process of using just three external standards—10 V, 1 ohm and 10 k ohm, to automatically adjust the entire instrument—optimizes performance to the best specified performance
- Cal Check—a process that tests all function and ranges for any drift since the most recent calibration—provides ongoing confidence in performance. Any output drift is measured and evaluated it with respect to specification.
- Compatible with 52120A and 5725A amplifiers
- Full MET/CAL® compatibility with 5700A and 5720A procedures (MET/CAL versions 7.3 and above)
- 30 MHz and 50 MHz wideband output options available



5322A Electrical Safety Tester Calibrator

Calibrate your entire electrical safety tester workload even more easily and efficiently!

The 5322A Electrical Safety Tester Calibrator helps calibration technicians comply with new regulatory standards up to four times faster than with traditional manual, multiple-product methods.

The 5322A facilitates compliance with exacting international standards such as the United Kingdom's BS7671 17th Edition, IEC/EN Standards, Australia and New Zealand's AS/NZS 3000 and Chinese verification/calibration regulations for various electrical testers.

The 5322A combines many functions into a single instrument, replacing discrete resistors, decade boxes and other custom solutions commonly used to calibrate electrical testers. This single-box solution speeds and simplifies calibration because users only need to learn, operate and maintain one calibrator rather than multiple instruments. And while it's difficult to automate multiple testers, the 5322A can be automated with MET/CAL™ Calibration Software—further increasing speed and throughput.

Workload includes insulation resistance testers; leakage current testers; multifunction installation testers; portable appliance testers (PATs); continuity testers and earth (ground) resistance testers; loop/line impedance testers and ground bond testers; residual-current device (RCD) or ground fault current interrupter (GFCI) testers; and hipot testers.

The 5322A is available in multiple models, offering the flexibility to select the features best suited to your lab's workload:

- The base 5322A model offers 1.5 kV high resistance sourcing.
- The 5322A/5 offers 5 kV high voltage resistor sourcing.

Selection guide

	Multi-Product Calibrators			Multifunction Calibrators	Oscilloscope Calibrators	Electrical Tester Calibrator	Power and Energy Calibrators and Standards			Precision Process Calibrators	
											
Workload	5080A	5502A	5522A	5730A	9500B	5322A	6003A	6100B	6105A	525B	7526A
Analog/panel meters											
High burden meters											
Low burden meters						V dc & V ac				V dc, I dc & R	V dc, I dc & R
DMMs											
Basic dc V accuracy	100 ppm	50 ppm	11 ppm	3.5 ppm	n/a	0.10 %	375 ppm	112 ppm	42 ppm	40 ppm	40 ppm
3.5 digits (typ. ± 0.3 % dc V)						V dc & V ac				V dc, I dc & R	V dc & V ac
4.5 digits (typ. ± 0.025 % dc V)											
5.5 digits (typ. ± 0.015 % dc V)											
6.5 digits (typ. ± 0.0030 % dc V)											
7.5 digits (typ. ± 16 ppm dc V)											
8.5 digits (typ. ± 8 ppm dc V)											
Temperature/pressure											
RTD simulate											
RTD measure											
Thermocouple simulate											
Thermocouple measure											
Pressure modules			opt							opt	opt
Two-wire transmitters											
Oscilloscopes											
	1 to 5 channels										
200 MHz to 600 MHz	200 MHz opt	300 MHz or 600 MHz opt	600 MHz opt			600 MHz std					
1.1 GHz			1 GHz opt			9510 Head opt					
3.2 GHz						9530 Head opt					
6.4 GHz						9560 Head opt					
25 ps fast edge (14 GHz)						9550 Head opt					
Safety testers											
Hipot											
Megohm meters	MEG opt										
Installation											
PATs											
Continuity	MEG opt										
Loop impedance											
Leakage current											
Ground bond											
RCD/GFCI											
Medical safety											
Power/energy											
Wattmeters											
Harmonic analyzers							PQ opt				
Flicker meters			PQ opt				PQ opt				
Phase angle meters			PQ opt								
Power analyzers			PQ opt				PQ opt				
Power recorders											
Secondary energy standards											
Watt-hour/energy meters							E opt				
Other											
Clamp meters				52120A Amp + COIL Opt			52120A Amp + COIL Opt				
LCR meters		RC only	RC only								
Process calibrators											
Data acquisition											
Non sine waveforms											
RF millivolt meters				30 and 50 MHz WB opt							
# of calibrator functions	8	11	11	5	11+	9	9	8	8	9	9



5522A

DC/LF Electrical calibrators

5730A Multifunction Calibrator

The new gold standard in electrical calibration.

- The next generation high-performance multifunction calibrator
- Support instruments of up to 8.5 digits in measurement performance
- Artifact Calibration permits the lowest cost of support and highest confidence in performance
- New internal printed circuit boards with upgraded digital technology
- 6.5 inch VGA capacitive touchscreen with full color graphical user interface
- Menus and functions displayed in choice of nine languages
- Optional wideband outputs to 30 or 50 MHz



5730A



5502A



5080A

5522A Multi-Product Calibrator

Robust, transportable wide workload coverage.

- Calibrates a wide variety of electrical test equipment with more than 14 functional capabilities
- Accuracies intended to support DMMs to 6.5 digits
- Robust protection circuits prevent costly damage from operator error
- Optional oscilloscope calibration to 1100 MHz
- Easy to transport

5502A Multi-Product Calibrator

Robust, transportable solution to match your workload and budget.

- Calibrates a wide variety of electrical test equipment
- Robust protection circuits prevent costly damage from operator error
- Ergonomically designed carrying handles
- Rugged optional case with built-in handles and wheels and removable front/rear access doors
- Optional oscilloscope calibration to 600 MHz

5080A High Compliance Multi-Product Calibrator

Solutions for your analog and digital workload.

- High compliance for difficult-to-calibrate analog instruments
- Robust protection circuits prevent costly damage from operator error
- Calibrates a wide workload, including analog meters and 3.5 and 4.5 digit DMMs
- Options for oscilloscope and megohm meter calibration



6105A/6100B



52120A



7526A



5725A



5322A



6003A



6135A/PMU

Specialty calibrators

6105A/6100B Electrical Power Standards

The most accurate, comprehensive and flexible sources of electrical power quality and energy signals.

- Power calibration with voltage to 1008 V and current to 21 amps, and optionally up to 80 amps
- Voltage and current accuracies better than 0.005 % (50 ppm)
- Current to voltage phase accuracy of 0.003 °
- Programmable harmonic distortion up to 100 harmonics
- Includes other power quality testing phenomena
- Complex measurements generating a wide variety of signals

5725A Amplifier

The Fluke 5725A Amplifier is a companion to the 57XX Series calibrators.

- Extends the calibrators' alternating volt-hertz product to 1100 V at 30 kHz and 750 V at 100 kHz
- Increases maximum direct and alternating current to 11 A

52120A Transconductance Amplifier

Test and calibrate power standards, power and energy meters, PQ analyzers, high-current clamp meters and Rogowski coils.

Delivers:

- 120 A stand-alone
- 240 A or 360 A with parallel operation
- 3000 A or 6000 A with accessory coils
- Industry-leading amplifier accuracy:
 - 100 PPM dc to 850 Hz
 - 120 PPM dc and 260 PPM ac in stand-alone operation
- Frequency capability, dc to 10 kHz

7526A Precision Process Calibrator

Best balance of economy and accuracy for calibration of temperature and pressure process measurement instrumentation.

- Sources and measures dc voltage, current, resistance
- Measures and simulates RTDs and thermocouples
- Measures pressure using Fluke 750 Series pressure modules
- Includes 24 V dc loop power supply, automated switch-test function and measures 4 mA to 20 mA

6003A Three Phase Electrical Power Calibrator

Three power phases in a single easy-to-use instrument.

- Cost effective
- Easy to use
- Simulates dc or ac electrical power and energy in voltage range to 600 ac V or 280 dc V and current range to 30 A per phase or 90 A combined
- Phase shift between voltage and current channels can be set from 0° to 359.99°

6135A/PMU Phasor Measurement Unit Calibrator

Fast, automated, IEEE C37 118.1-2011-compliant PMU calibrations. System includes:

- PMU control unit
- GPS receiver
- PMU test and calibration software
- Fluke 6135 Electrical Power Standard
- Configured server PC

5322A Electrical Safety Tester Calibrator

Calibrate all major types of electrical safety testers with just one calibrator

- Calibrate insulation resistance testers; leakage current testers; multifunction installation testers; portable appliance testers (PATs); continuity testers, earth (ground) resistance testers and many more types of electrical safety testers
- Complies with new regulatory standards up to four times faster than traditional methods
- Compatible with MET/CAL software

525B Temperature/Pressure Calibrator

Superior accuracy and functionality in an economical benchtop package.

- A calibrator to address process industry instrumentation
- Simulates and measures all ANSI thermocouples, as well as L and U types, and provides cold junction compensation to enable calibration of a wide variety of thermocouple instrumentation
- Direct input for storage of ITS-90 RTD constants
- RTD source uncertainties to 0.03 °C



525B



55XX



9500B

Oscilloscope calibrators

9500B Oscilloscope Calibrator

The highest performance, fully automated, upgradeable oscilloscope calibration workstation.

- Full automation provides totally hands-free calibration
- Bandwidths of 600 MHz, 1,000 MHz, 3,200 MHz, and 6,400 MHz
- A fast edge of 25 ps to address bandwidths up to 14 GHz
- Connect up to five channels simultaneously

55XX Series Oscilloscope Calibration Options

Options for the 5502A and 5522A calibrators add capabilities to calibrate your digital and analog oscilloscopes with any of three different ranges of bandwidths.

- Leveled sine wave generator with optional bandwidths of 300 MHz, 600 MHz and 1100 MHz for verifying oscilloscope bandwidth
- DC and square wave voltage generators for calibrating voltage gain
- Horizontal time base calibration functions
- Edge source including a 300 ps fast edge with low aberrations for verifying dynamic response
- Fast edge risetime pulse generator (< 1 ns) for checking pulse response

Precision multimeters

8588A Reference Multimeter

The world's most stable digitizing reference multimeter

- 8.5 digit resolution, exceptional linearity and low noise and stability
- Guaranteed 3.5 ppm 1 year accuracy (99 %) analog performance without self-calibration
- AC rms measurement performance that is ten times faster, two times less noisy, and more sensitive for low level signals than other instruments in this class
- 0 to 10 s aperture setting allows industry's widest flexibility to control data capture window
- Intuitive menu structure and graphical display that enables instantaneous visualization of trend plot, statistical analysis, histogram and FFT
- GPIB, USBTMC, Ethernet allows industry standard selection of remote interface



8588A/8558A

8558A 8.5 Digit Multimeter

The industry's fastest direct 5 mega-samples-per-second digitizing for system automation in labs and manufacturing test environments.

- Digitizes at 5 MS/s, 18-bit resolution into memory for capturing complex, fast changing waveforms
- Up to 20 MHz bandwidth for voltage and 4 MHz for current retains high bandwidth content of the signal measured
- 4.5 digit data delivered to a PC at 100 kilo-readings/s



732C/734C

Electrical standards

732C/734C DC Reference Standards

The simple way to maintain and disseminate 10 V, 1.0 V and 0.1 V

- A primary standard for traceability of dc voltage to better than 1 ppm
- Eliminates the need for external dividers
- Complete mechanical and electrical independence of each of its four 732C standards
- Battery powered for easy shipping

5790B AC Measurement Standard

Easiest way to make precision ac measurements

- AC voltage measurement uncertainties as low as ± 24 ppm
- Works with A40B shunts for making precise absolute and relative current measurements without requiring manual current value calculations
- 30 MHz and 50 MHz wideband range options
- Statistics and peak-to-peak waveform functions
- Intuitive graphical interface
- Visual Connection Management™ terminals that light up to show the active terminals

742A Resistance Standard

High accuracy working standard for on-site resistance calibration.

- Small and rugged standard resistors with six-month stabilities to 2.5 ppm
- Open air use so no oil or air baths required
- 18 °C to 28 °C operating range
- Standard values from 1 ohm to 100 Megohms



5790B



A40B



910/910R

A40B Series Precision Current Shunts

Precision, low inductance shunts for dc and ac current metrology.

- Simplifies calibration/verification of precision calibrators and current sources
- Shunts sized for current from 1 mA to 100 A
- Usable from dc to 100 kHz
- Ultra low phase shift to support power quality instrument metrology

752A Reference Divider

Setting the standard for ratio accuracy and ease of use.

- Key standard for calibrating 57xx Series Calibrators
- 10:1 and 100:1 divider outputs
- Output uncertainty 0.2 ppm and 0.5 ppm
- Built-in calibration bridge

910/910R GPS Controlled Frequency Standard

Cesium controlled frequency standard that uses GPS technology and connectivity to provide primary standard traceability from any location.

- Unique traceability feature means no more re-calibrations
- Two high-stability models to meet your application and fit your budget
- Built-in rubidium atomic clock (910R)
- Up to 13 outputs, maximizing cost efficiency



742A



752A



908/909

908/909 Frequency References

Stable frequency references for test systems and calibration labs.

- Accurate reference atomic clock in automated test systems
- Affordable and very cost effective
- Designed for portability with optional carrying case



RF calibration

RF and microwave calibration refers to the process of verifying the performance of, or adjusting/deriving corrections for, any instrument or component that will be used in the measurement or testing of RF and microwave parameters. This discipline is usually referred to as RF and microwave metrology. Principal parameters include RF voltage, RF power, impedance, modulation, distortion, time, frequency and phase. High dynamic range ratiometric comparisons are often performed and results are expressed in the logarithmic dB form.

As with any other calibration, RF and microwave calibration compares a device or unit under test (DUT or UUT) to a traceably calibrated standard or reference device. The process typically involves comparing a measuring UUT to a reference source; a sourcing UUT with a measuring reference; or quite commonly a measuring UUT with a measuring reference, using a stable but unknown source.

In each case, the uncertainty or stability of the reference should significantly exceed the specified performance of the device or unit under test. RF metrologists typically look for performance margins of 4:1, however, test uncertainty ratios lower than this usual target are more frequently encountered in RF than in other calibration disciplines. Conversion from logarithmic (dB) to linear units is recommended practice when combining uncertainty contributions and considering test uncertainty ratios.

Precision devices that are commonly used in RF and microwave calibration fall broadly into four categories:

Sourcing instruments. Reference signals and/or modulation sources, frequency references, pulse or arbitrary waveform generators, reference attenuators.

Measuring instruments. Power sensors, spectrum analyzers, measuring receivers, oscilloscopes, RF voltmeters, frequency counters.

Source-measure instruments. Vector or scalar network analyzers.

Precision components

- Power splitters, power dividers or couplers, attenuating pads
- Inter-series, polarity or sacrificial cables and adapters
- Short, open, load or sliding terminators
- Reflection bridges or directional couplers



96270A



96040A

RF references

96270A 27 GHz Low Phase Noise Reference Source

The simplest, most accurate and cost effective single instrument for calibrating spectrum analyzers, RF power sensors and more.

- Self-characterization lets you avoid calculating correction factors for each component in the signal delivery system
- What you set is what you get. Accurate signal delivery direct to the UUT input up to 27 GHz
- Covers a broad range of RF calibration workload
- Reduces the number of instruments and interconnections required for your RF calibration system
- Integrated 300 MHz frequency counter and dual power meter readout eliminate need for additional instruments
- Calibration-specific interface simplifies technician tasks
- Simplifies uncertainty calculations
- Lowers RF system maintenance costs
- With automation, reduces spectrum analyzer calibration times by as much as 50 % over manual methods
- Directly replaces and emulates legacy HP3335A, HP8662A, HP8663A, HP8340A, and HP8360B generators

96040A Low Phase Noise Reference Source

Simplify your RF calibration system by replacing many of the instruments and accessories that make up your current system.

- Covers a broad range of RF calibration workload
- Reduces the number of instruments and interconnections required for your RF calibration system
- What you set is what you get. Accurate signal delivery direct to the UUT input
- Integrated 50 MHz frequency counter eliminates need for an additional instrument
- Calibration-specific interface simplifies technician tasks
- Simplifies uncertainty calculations by delivering known signals direct to the unit under test (UUT)
- Lowers RF system maintenance costs
- With automation, reduces spectrum analyzer calibration times by as much as 50 % over manual methods
- Directly replaces and emulates legacy HP3335A, HP8662A, and HP8663A generators



Temperature calibration

Temperature calibration refers to the calibration of any device used in a system that measures temperature. Most importantly, this usually means the temperature sensor, itself, which is typically a platinum resistance thermometer (PRT or PT-100), thermistor, or thermocouple. Readings from these thermometers are made by thermometer readout devices which measure their electrical outputs and convert them to temperature according to the International Temperature Scale of 1990 (ITS-90).

Thermometers are typically calibrated by placing them in a stable temperature environment (heat source) and comparing their output to that of a calibrated reference thermometer or standard

thermometer. Fluke Calibration provides three general categories of heat sources: industrial heat sources (dry-well calibrators, portable calibration baths, Micro-Baths, etc.) for field use; fluid baths and thermocouple furnaces for laboratory use; and fixed-point cells for primary calibrations. Fluke Calibration also offers a variety of reference thermometers, including SPRTs, and thermometer readout instruments.

In addition, Fluke Calibration provides laboratory and field solutions for calibrating the electronics used in temperature measurement circuits.

Product highlights



6109A/7109A Portable Calibration Baths

Four times more calibration throughput with twice the accuracy of Micro-Baths and dry-block calibrators

Now there are portable calibration baths (6109A and 7109A) designed with the process manufacturing professional in mind. Process manufacturing plants for pharmaceuticals, biotechnology, and food production utilize many sanitary temperature sensors that require regular calibration. Production must stop during temperature sensor calibration. Therefore, more calibration throughput means less plant downtime.

The Fluke Calibration 6109A and 7109A Portable Calibration Baths are liquid baths that let process industry professionals calibrate four times more sanitary sensors per batch in less time and with twice the accuracy of other portable baths in this class. Larger than micro baths, up to four tri-clamp sanitary sensors fit easily into these baths for calibration at ± 0.1 °C temperature display accuracy. Calibrate up to four tri-clamp sanitary sensors at the same time.

- Wide temperature ranges cover most process applications
 - 6109A: 35 °C to 250 °C
 - 7109A: -25 °C to 140 °C
- Excellent display accuracy of ± 0.1 °C provides 4:1 test uncertainty ratio for critical applications
- Stainless steel casing withstands harsh sterilizing chemicals and is rust proof
- NVLAP-accredited calibration included standard



1586A Super-DAQ Precision Temperature Scanner

The most accurate, flexible temperature data acquisition system

The 1586A is ideal for benchtop calibration of temperature sensors in secondary calibration labs, as well as temperature data acquisition applications in industries such as pharmaceutical, biotechnology, aerospace, food and energy where accurate temperature measurements are critical.

- Flexible configuration for the benchtop or factory using the DAQ-STAQ Multiplexer or internal High-Capacity Module
- Measure thermocouples, PRTs, thermistors, dc V, dc I, and resistance
- Best-in-class temperature measurement accuracy:
 - PRTs: ± 0.005 °C (using DAQ-STAQ Multiplexer)
 - Thermocouples: ± 0.29 °C (using DAQ-STAQ Multiplexer and internal CJC for type K at 0 °C)
 - Thermistors: ± 0.002 °C
- Connect up to 40 isolated inputs
- Scan speed of up to 10 channels per second
- Four modes of operation: Scan, Monitor, Measure, DMM
- Real-time color trending—chart up to four channels simultaneously
- Controls Fluke Calibration temperature sources such as dry-wells, furnaces or Micro-Baths for automated calibration routines
- MX + B scaling and channel offset zero function
- Built-in data security levels

Selection guides

Primary standards

Standard platinum resistance thermometers (SPRTs)		
Model	RTPW	Description
5681	25.5 Ω	-200 °C to 670 °C, quartz sheath
5683	25.5 Ω	-200 °C to 480 °C, quartz sheath
5684	0.25 Ω	0 °C to 1070 °C, quartz sheath
5685	2.5 Ω	0 °C to 1070 °C, quartz sheath
5698	25.5 Ω	-200 °C to 670 °C, working standard, quartz sheath
5699	25.5 Ω	-200 °C to 670 °C, high temperature, metal sheath
5686	25.5 Ω	-260 °C to 232 °C, glass capsule

ITS-90 fixed-point cells

Model	Description	Temperature
Triple point of water cells		
5901A-G	TPW Cell, 12 mm ID with handle, glass shell	0.01 °C
5901A-Q	TPW Cell, 12 mm ID with handle, quartz shell	0.01 °C
5901C-G	TPW Cell, 13.6 mm ID with handle, glass shell	0.01 °C
5901C-Q	TPW Cell, 13.6 mm ID with handle, quartz shell	0.01 °C
5901D-G	TPW Cell, 12 mm ID, glass shell	0.01 °C
5901D-Q	TPW Cell, 12 mm ID, quartz shell	0.01 °C
5901B-G	TPW Cell, mini, glass shell	0.01 °C
Standard size fixed-point cells		
5900E	TP mercury, SST	-38.8344 °C
5904	Freezing point of indium	156.5985 °C
5905	Freezing point of tin	231.928 °C
5906	Freezing point of zinc	419.527 °C
5907	Freezing point of aluminum	660.323 °C
5908	Freezing point of silver	961.78 °C
5909	Freezing point of copper	1084.62 °C
5924	Open freezing point of indium	156.5985 °C
5925	Open freezing point of tin	231.928 °C
5926	Open freezing point of zinc	419.527 °C
5927A	Open freezing point of aluminum	660.323 °C
5928	Open freezing point of silver	961.78 °C
5929	Open freezing point of copper	1084.62 °C
5943	Melting point of gallium, SST	29.7646 °C
Mini triple point of water and fixed-point cells		
5901B	Mini triple point of water	0.01 °C
5914A	Mini freezing point of indium	156.5985 °C
5915A	Mini freezing point of tin	231.928 °C
5916A	Mini freezing point of zinc	419.527 °C
5917A	Mini freezing point of aluminum	660.323 °C
5918A	Mini freezing point of silver	961.78 °C
5919A	Mini freezing point of copper	1084.62 °C
5944	Mini freezing point of indium, metal cased	156.5985 °C
5945	Mini freezing point of tin, metal cased	231.928 °C
5946	Mini freezing point of zinc, metal cased	419.527 °C
5947	Mini freezing point of aluminum, metal cased	660.323 °C

Model	Features/use
Maintenance apparatus	
7012	Maintains: triple point of water and gallium cells. Comparisons: -10 °C to 110 °C.
7037	Maintains: triple point of water and gallium cells. Comparisons: -40 °C to 110 °C.
7312	Maintains: two TPW cells. Compact size, runs quietly. Comparisons: -5 °C to 110 °C.
7341	Maintains: triple point of mercury cell. Comparisons: -45 °C to 150 °C.
9210	Maintains: mini triple point of water. Comparisons: -10 °C to 125 °C.
9230	Maintains: stainless steel gallium cell. Comparisons: 15 °C to 35 °C.
9260	Maintains: indium, tin, zinc, and aluminum cells. Comparisons: 50 °C to 680 °C.
9114	Maintains: indium, tin, zinc, and aluminum cells. Comparisons: 100 °C to 680 °C.
9115A	Maintains: aluminum and silver cells. Comparisons: 550 °C to 1000 °C.
9116A	Maintains: aluminum, silver, gold, and copper cells. Comparisons: 400 °C to 1100 °C.
9117	Anneals SPRTs, HTPRTs, and thermocouples to 1100 °C. Protects them against contamination from metal ions.
Boiling point of liquid nitrogen	
7196	Affordable substitute for a triple point of argon system. Provides for low-temperature comparison calibrations at approximately -196 °C with uncertainties of 2 mK.
Triple point of argon system	
5960A	Lowest uncertainty for any commercially available triple point of argon system.
Standard resistors	
742A	Excellent performance without oil or air baths. Values from 1 ohm to 19 megohm.

Thermometer readouts

Intrinsically safe thermometers			
1551A Ex	100 Ω thin-film RTD	-50 °C to 160 °C (-58 °F to 320 °F)	Accuracy of ± 0.05 °C (± 0.09 °F) over full range. Intrinsically safe (ATEX and IECEx compliant). Two models to choose from (-50 °C to 160 °C or -80 °C to 300 °C)
1552A Ex	100 Ω wire-wound PRT	-80 °C to 300 °C (-112 °F to 572 °F)	
Precision digital thermometer readouts			
Model	Probe types	Accuracy at 0 °C	Features
Tweener			
1502A	PRTs	± 0.006 °C	Resolution of 0.001 °C and accuracy to match; uses ITS-90, IPTS-68, CVD, or DIN (IEC 751) conversions
1504	Thermistors	± 0.002 °C	Reads thermistors from 0 to 500 KW; uses Steinhart-Hart and CVD
Handheld			
1523	PRTs, Thermistors, Thermocouples	± 0.015 °C (PRTs)	Battery-powered, handheld reference thermometer; INFO-CON connector reads coefficients without programming; saves 25 readings on demand; graphs trends
1524	PRTs, Thermistors, Thermocouples	± 0.015 °C (PRTs)	Handheld reference thermometer same as 1523 but with inputs for two thermometers; logs up to 15,000 readings and stores 25 more on demand
Chub-E4			
1529	PRTs, Thermistors, Thermocouples	± 0.006 °C (PRTs)	Four channels can all be measured simultaneously; battery-powered; logs up to 8,000 readings; flexible display
Super-Thermometers			
1594A	SPRTs, PRTs, Thermistors	± 0.00006 °C	Ratio accuracy of 0.8 ppm; temperature-controlled internal reference resistors; six input channels
1595A	SPRTs, PRTs, Thermistors	± 0.000015 °C	Ratio accuracy of 0.2 ppm; Ratio Self-Calibration; automated zero-power measurements
Multi-channel			
1586A	PRTs, Thermistors, Thermocouples	± 0.005 °C (PRTs)	40 channels with scan rate of 10 channels per second
1560	Accepts any combination of the modules below; all are easily added to and removed from the 1560 Black Stack base		
2560	SPRTs, PRTs	± 0.005 °C	2 channels of 25W or 100W PRTs
2561	HTPRTs	± 0.013 °C	2 channels to 1200 °C
2562	PRTs	± 0.01 °C	8 channels of 2-, 3-, or 4-wire RTDs
2563	Thermistors	± 0.0013 °C	2 channels of resolution to 0.0001 °C
2564	Thermistors	± 0.0025 °C	8 channels for data acquisition
2565	Thermocouples	± 0.05 °C	Reads most TC types with 0.0001 mV resolution
2566	Thermocouples	± 0.1 °C	Reads any combination up to 12 channels of virtually any type of TC
2567	1000 Ω PRTs	± 0.006 °C	2 channels of high-resistance PRTs
2568	1000 Ω PRTs	± 0.01 °C	8 channels of high-resistance PRTs
Thermo-hygrometer			
1620A	The DewK Thermo-Hygrometer	Two channels measure ambient temperature to ± 0.125 °C and %RH to ± 1.5 %. Onboard memory holds up to two years of time/date-stamped readings. Visual and audio alarms. Detachable sensors contain their own calibration data for easy recalibrations. Ethernet and wireless capabilities.	

Thermometer probes

Platinum resistance thermometers (PRTs)			
Model	Range	Size	Basic Accuracy†
Secondary standard PRT			
5608-9-X	-200 °C to 500 °C	229 mm x 3.18 mm (9 in x 0.125 in)	Select from available calibration options
5608-12-X	-200 °C to 500 °C	305 mm x 3.18 mm (12 in x 0.125 in)	
5609-12-X	-200 °C to 670 °C	305 mm x 6.35 mm (12 in x 0.25 in)	
5609-15-X	-200 °C to 670 °C	381 mm x 6.35 mm (15 in x 0.25 in)	
5609-20-X	-200 °C to 670 °C	508 mm x 6.35 mm (20 in x 0.25 in)	
5609-300-X	-200 °C to 670 °C	300 mm x 6 mm (11.81 in x 0.24 in)	
5609-400-X	-200 °C to 670 °C	400 mm x 6 mm (15.75 in x 0.24 in)	
5609-500-X	-200 °C to 670 °C	500 mm x 6 mm (19.69 in x 0.24 in)	
5626	-200 °C to 661 °C	305 or 381 mm x 6.35 mm (12 or 15 in x 0.25 in)	± 0.007 °C at 0 °C
5628	-200 °C to 661 °C	305 or 381 mm x 6.35 mm (12 or 15 in x 0.25 in)	± 0.006 °C at 0 °C
Secondary reference PRT			
5615-6	-200 °C to 300 °C	152 mm x 4.76 mm (6 in x 0.19 in)	± 0.013 °C at 0.010 °C
5615-9	-200 °C to 420 °C	229 mm x 4.76 mm (9 in x 0.19 in)	± 0.013 °C at 0.010 °C
5615-12	-200 °C to 420 °C	305 mm x 6.35 mm (12 in x 0.25 in)	± 0.013 °C at 0.010 °C
Precision industrial PRT			
5627A-6	-200 °C to 300 °C	152 mm x 4.7 mm (6 in x 0.19 in)	± 0.05 °C at 0 °C
5627A-9	-200 °C to 300 °C	229 mm x 4.7 mm (9 in x 0.19 in)	± 0.05 °C at 0 °C
5627A-12	-200 °C to 420 °C	305 mm x 6.35 mm (12 in x 0.25 in)	± 0.05 °C at 0 °C
Fast response PRT			
5622-05	-200 °C to 350 °C	100 mm x 0.5 mm (3.94 in x 0.02 in)	± 0.04 °C at 0 °C
5622-10	-200 °C to 350 °C	100 mm x 1.0 mm (3.94 in x 0.04 in)	± 0.04 °C at 0 °C
5622-16	-200 °C to 350 °C	200 mm x 1.6 mm (7.87 in x 0.06 in)	± 0.04 °C at 0 °C
5622-32	-200 °C to 350 °C	200 mm x 3.2 mm (7.87 in x 0.125 in)	± 0.04 °C at 0 °C
Small diameter industrial PRTs			
5618B-6	-200 °C to 300 °C	152 mm x 3.2 mm (6 in x 0.125 in)	± 0.05 °C
5618B-9	-200 °C to 500 °C	229 mm x 3.2 mm (9 in x 0.125 in)	± 0.05 °C
5618B-12	-200 °C to 500 °C	305 mm x 3.2 mm (12 in x 0.125 in)	± 0.05 °C
Full immersion PRTs			
5606 Immersion PRT	-200 °C to 160 °C	50 mm x 3.2 mm (1.97 in x 0.125 in)	± 0.05 °C
5623B Freezer Probe	-100 °C to 156 °C	152 mm x 6.35 mm (6 in x 0.25 in)	± 0.05 °C
High temperature PRT			
5624	0 °C to 1000 °C	508 mm x 6.35 mm (20 in x 0.25 in)	± 0.055 °C
Thermistors			
Standards			
5640	0 °C to 60 °C	229 mm x 6.35 mm (9 in x 0.25 in)	± 0.0015 °C
5641	0 °C to 60 °C	114 mm x 3.2 mm (4.5 in x 0.125 in)	± 0.001 °C
5642	0 °C to 60 °C	229 mm x 3.2 mm (9 in x 0.125 in)	± 0.001 °C
5643	0 °C to 100 °C	114 mm x 3.2 mm (4.5 in x 0.125 in)	± 0.0025 °C
5644	0 °C to 100 °C	229 mm x 3.2 mm (9 in x 0.125 in)	± 0.0025 °C
Secondary probes			
5610	0 °C to 100 °C	152 or 229 mm x 3.2 mm (6 or 9 in x 0.125 in)	± 0.01 °C
5611A	0 °C to 100 °C	1.5 mm (0.06 in) tip dia.	± 0.01 °C
5611T	0 °C to 100 °C	28 mm x 3 mm (1.1 in x 0.12 in)	± 0.01 °C
5665	0 °C to 100 °C	76 mm x 3.2 mm (3 in x 0.125 in)	± 0.01 °C
Thermocouples			
Type R and S standards			
5649/5650-20	0 °C to 1450 °C	508 mm x 6.35 mm (20 in x 0.25 in)	± 0.7 °C at 1100 °C
5649/5650-20C	0 °C to 1450 °C	508 mm x 6.35 mm (20 in x 0.25 in)	± 0.7 °C at 1100 °C
5649/5650-25	0 °C to 1450 °C	635 mm x 6.35 mm (25 in x 0.25 in)	± 0.7 °C at 1100 °C
5649/5650-25C	0 °C to 1450 °C	635 mm x 6.35 mm (25 in x 0.25 in)	± 0.7 °C at 1100 °C

†“Basic Accuracy” includes calibration uncertainty and short-term repeatability. It does not include long-term drift.

Calibration baths

Compact calibration baths			
Model	Range	Stability	Depth
6332A*	50 °C to 300 °C (122 °F to 572 °F)	± 0.01 °C	450 mm (17.7 in)
7342A*	-40 °C to 150 °C (-40 °F to 302 °F)	± 0.01 °C	450 mm (17.7 in)
6330	35 °C to 300 °C (95 °F to 572 °F)	± 0.005 °C at 100 °C ± 0.015 °C at 300 °C	234 mm (9.25 in)
7320	-20 °C to 150 °C (-4 °F to 302 °F)	± 0.005 °C at -20 °C ± 0.005 °C at 25 °C	234 mm (9.25 in)
7340	-40 °C to 150 °C (-40 °F to 302 °F)	± 0.005 °C at -40 °C ± 0.005 °C at 25 °C	234 mm (9.25 in)
7380	-80 °C to 100 °C (-112 °F to 212 °F)	± 0.006 °C at -80 °C ± 0.010 °C at 0 °C	178 mm (7 in)
6331	35 °C to 300 °C (95 °F to 572 °F)	± 0.015 °C at 300 °C ± 0.005 °C at -20 °C	457 mm (18 in)
7321	-20 °C to 150 °C (-4 °F to 302 °F)	± 0.005 °C at 25 °C ± 0.005 °C at -40 °C	457 mm (18 in)
7341	-45 °C to 150 °C (-49 °F to 302 °F)	± 0.005 °C at -40 °C ± 0.005 °C at 25 °C	457 mm (18 in)
7381	-80 °C to 110 °C (-112 °F to 230 °F)	± 0.006 °C at -80 °C ± 0.005 °C at 0 °C	457 mm (18 in)
Standard size calibration baths			
7080	-80 °C to 110 °C (-112 °F to 230 °F)	± 0.0025 °C at -80 °C ± 0.0015 °C at 25 °C	305 mm (12 in)
7008	-5 °C to 110 °C (23 °F to 230 °F)	± 0.0007 °C at 25 °C ± 0.0008 °C at 0 °C	331 mm (13 in)
7011	-10 °C to 110 °C (14 °F to 230 °F)	± 0.0008 °C at 25 °C ± 0.0008 °C at 0 °C	305 mm (12 in)
7040	-40 °C to 110 °C (-40 °F to 230 °F)	± 0.0015 °C at 25 °C ± 0.001 °C at 40 °C	305 mm (12 in)
6020	40 °C to 300 °C (104 °F to 572 °F)	± 0.005 °C at 300 °C ± 0.001 °C at 40 °C	305 mm (12 in)
6022	40 °C to 300 °C (104 °F to 572 °F)	± 0.005 °C at 300 °C ± 0.001 °C at 40 °C	464 mm (18.25 in)
6024	40 °C to 300 °C (104 °F to 572 °F)	± 0.005 °C at 300 °C ± 0.002 °C at 200 °C	337 mm (13.25 in)
6050H	180 °C to 550 °C (356 °F to 1022 °F)	± 0.007 °C at 500 °C ± 0.006 °C at -80 °C	305 mm (12 in)
Other			
Item	Description		
Bath accessories	Stands, rods, and clamps to suspend and support your probes and thermometers.		
Bath fluids	Silicone oils, salt, and cold fluids in convenient, small quantities.		
Rosemount bath controllers	Model 7900 controller designed by Hart integrates the features of Hart's 2100 controller and can be used in place of the Rosemount 915 controller with Rosemount-designed baths.		
Fluke Calibration bath controllers	Model 2100 and 2200 controllers can be integrated with homemade baths or other heat sources to achieve performance levels approaching Fluke Calibration baths.		

*Not for sale in Europe

Industrial temperature calibrators

Field metrology wells		
Model	Range	Accuracy
9190A	-95 °C to 140 °C (-139 °F to 284 °F)	± 0.2 °C
9142	-25 °C to 150 °C (-13 °F to 302 °F)	± 0.2 °C
9143	33 °C to 350 °C (91 °F to 662 °F)	± 0.2 °C
9144	50 °C to 660 °C (122 °F to 1220 °F)	± 0.35 °C at 50 °C ± 0.35 °C at 420 °C ± 0.5 °C at 660 °C
Portable calibration baths		
6109A	35 °C to 250 °C (95 °F to 482 °F)	± 0.1 °C
7109A	-25 °C to 140 °C (-13 °F to 284 °F)	± 0.1 °C
Micro-Baths		
6102	35 °C to 200 °C (95 °F to 392 °F)	± 0.25 °C
7102	-5 °C to 125 °C (23 °F to 257 °F)	± 0.25 °C
7103	-30 °C to 125 °C (-22 °F to 257 °F)	± 0.25 °C
Handheld dry-wells		
9100S	35 °C to 375 °C (95 °F to 707 °F)	± 0.25 °C at 100 °C ± 0.5 °C at 375 °C
9102S	-10 °C to 122 °C (14 °F to 252 °F)	± 0.25 °C
Field dry-wells		
9009	-15 °C to 350 °C (5 °F to 662 °F)	Cold block: ± 0.2 °C Hot block: ± 0.6 °C
9103	-25 °C to 140 °C (-13 °F to 284 °F)	± 0.25 °C
9140	35 °C to 350 °C (95 °F to 662 °F)	± 0.5 °C
Infrared calibrators		
4180	-15 °C to 120 °C (5 °F to 248 °F)	± 0.40 °C at -15 °C ± 0.40 °C at 0 °C ± 0.50 °C at 50 °C ± 0.50 °C at 100 °C ± 0.55 °C at 120 °C
4181	35 °C to 500 °C (95 °F to 932 °F)	± 0.35 °C at 35 °C ± 0.50 °C at 100 °C ± 0.70 °C at 200 °C ± 1.20 °C at 350 °C ± 1.60 °C at 500 °C
9132	50 °C to 500 °C (122 °F to 932 °F)	± 0.5 °C at 100 °C ± 0.8 °C at 500 °C
9133	-30 °C to 150 °C (-22 °F to 302 °F)	± 0.4 °C
Metrology Wells		
9170	-45 °C to 140 °C (-49 °F to 284 °F)	± 0.1 °C
9171	-30 °C to 155 °C (-22 °F to 311 °F)	± 0.1 °C
9172	35 °C to 425 °C (95 °F to 797 °F)	± 0.1 °C at 100 °C ± 0.15 °C at 225 °C ± 0.2 °C at 425 °C
9173	50 °C to 700 °C (122 °F to 1292 °F)	± 0.2 °C at 425 °C ± 0.25 °C at 660 °C
Zero point dry-well		
9101	0 °C (32 °F)	± 0.05 °C
Dual block dry-well		
9011	50 °C to 670 °C (122 °F to 1238 °F)	± 0.2 °C at 50 °C ± 0.4 °C at 400 °C ± 0.65 °C at 600 °C
	-30 °C to 140 °C (-22 °F to 284 °F)	± 0.25 °C (insert wells) ± 0.65 °C (fixed wells)
Thermocouple furnaces		
9150	150 °C to 1200 °C (302 °F to 2192 °F)	± 5 °C
9118A	300 °C to 1200 °C (572 °F to 2192 °F)	± 5 °C



5681, 5683, 5684, and 5685



5698-25



5686-B



5699



5901



ITS-90

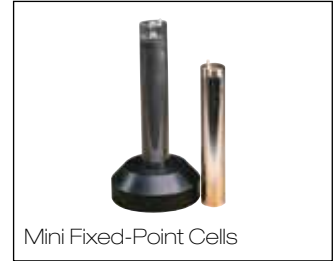

Mini Fixed-Point Cells

Standard platinum resistance thermometers (SPRTs)

5681, 5683, 5684, and 5685 Quartz-Sheath SPRTs

The performance you expect from world-class SPRTs.

- Drift rates as low as 0.0005 K
- Proprietary gas mixtures ensures high stability
- Most experienced SPRT design team in the business

5698-25 Working Standard SPRT

High performance-to-price ratio.

- Conforms to ITS-90 SPRT Guidelines
- Drift rate typically 0.003 °C
- Calibration options by fixed point

5686-B Glass Capsule SPRT

Designed for metrology work requiring small SPRTs.

- Temperatures from -260 °C (13 K) to 232 °C
- Stability typically 0.001 °C over 100 °C range
- Miniature capsule package eliminates stem conduction

5699 High-Temperature Metal-Sheath SPRT

Affordable working standard SPRT.

- Range to aluminum point (660 °C)
- Inconel™ sheaths guard against contamination of sensor
- Drift rates less than 8 mK/year

ITS-90 fixed-point cells

5901 Triple Point of Water Cells

Must-have, primary temperature standards.

- Easy-to-use, inexpensive standard with uncertainty better than ± 0.0001 °C
- Four sizes and two shells (glass and quartz) to choose from
- Isotopic composition of Vienna Standard Mean Ocean Water

ITS-90 Fixed-Point Cells

Best cell uncertainties commercially available.

- Every ITS-90 fixed point available from mercury to copper
- Plateaus last days (gallium for weeks and TPW for months)
- Manufactured and tested by Fluke Calibration's primary standards scientists

Mini Fixed-Point Cells

Least expensive, easiest-to-use fixed-point standards.

- Lower uncertainties than comparison calibrations
- All ITS-90 fixed points from TPW to copper
- Reduced equipment and annual recalibration costs



9114, 9115A, 9116A



9117



7196B

Cell maintenance apparatus



9210



9230



9260



7312

9114, 9115A, 9116A Freeze-Point Furnaces

Designed for maximum-length plateaus.

- Designed to extend plateaus
- High-stability OEM controllers, RS-232 included
- External cooling coils

9210 Mini Triple Point of Water Maintenance Apparatus

Simple supercool-and-shake realization and maintenance of the 5901B Mini TPW Cell.

- Easy preprogrammed realization
- Inexpensive fixed-point solution
- Training complete in less than an hour

9230 Gallium Cell Maintenance Apparatus

Realize and maintain the melting point of the 5943 Gallium Cell.

- One week plateau duration
- No hassle automatic realizations
- Used daily in our Primary Lab

9260 Mini Fixed-Point Cell Furnace

Inexpensive, easy-to-use fixed-point maintenance apparatus.

- Realize and maintain In, Sn, Zn and Al fixed-point cells
- Good introduction to fixed-point calibration
- User friendly and inexpensive

7012/7312 Triple Point of Water Maintenance Baths

Keep your cells up and running reliably for weeks at a time.

- Maintains TPW cells for up to six weeks
- Optional immersion freezer for simple cell freezing
- Up to 496 mm (19.5 in) of immersion depth

9117 Annealing Furnace

Keeps SPRTs and PRTs performing at their highest levels.

- Relieves mechanical strain
- Guards against contamination
- Anneals both SPRTs and HTSPRTs

7196B LN₂ Comparison Calibrator

Lowest-cost calibration to -196 °C.

- Simple to use
- Uncertainty less than 2 mK



1586A



DAQ-STAQ Multiplexer



1594A/1595A



1560



1529



1502A/1504



1523/1524



1551A Ex and 1552A Ex

Thermometer readouts

1586A Super-DAQ Precision Temperature Scanner and DAQ-STAQ Multiplexer

Best-in-class temperature measurement accuracy and up to 40 isolated input channels for measuring RTDs, thermocouples, thermistors, dc voltage, dc current, and resistance.

- PRTs: $\pm 0.005\text{ }^{\circ}\text{C}$;
Thermocouples: $\pm 0.29\text{ }^{\circ}\text{C}$;
Thermistors: $\pm 0.002\text{ }^{\circ}\text{C}$
- Scan speed of up to 10 channels per second
- Real-time color trending—chart up to four channels simultaneously
- Control Fluke Calibration temperature sources such as dry-wells or Micro-Baths for automated calibration routines

1594A/1595A Super-Thermometers

Thermometry bridge accuracy combined with time-saving features.

- Calibrate SPRTs, PRTs, RTDs and thermistors ($0\ \Omega$ to $500\ \text{k}\Omega$)
- Accuracy as good as $0.06\ \text{ppm}$ ($0.000015\text{ }^{\circ}\text{C}$)
- Ratio Self-Calibration verifies and calibrates resistance ratio accuracy

1560 Black Stack Thermometer Readout

Accurate, expandable and configurable readout.

- Reads SPRTs, RTDs, thermistors, and thermocouples
- Any configuration you like up to eight modules
- High-accuracy reference thermometer (to $\pm 0.0013\text{ }^{\circ}\text{C}$)

1529 Chub-E4 Standards Thermometer

Lab-quality accuracy on four channels for PRTs, thermistors and thermocouples.

- Four channels for PRTs, thermistors, and thermocouples
- Displays eight user-selected data fields from any channel
- Logs up to 8,000 readings with date and time stamps

1502A/1504 Reference Thermometers

Best performance thermometers in their price range.

- Single-channel reference thermometers
- Two models to choose from—reading PRTs or thermistors
- Best price/performance package

1523/1524 Reference Thermometers

Measure, graph and record three sensor types with one tool.

- High accuracy: PRTs: $\pm 0.011\text{ }^{\circ}\text{C}$;
Thermocouples: $\pm 0.24\text{ }^{\circ}\text{C}$; Thermistors: $\pm 0.002\text{ }^{\circ}\text{C}$
- A simple user interface to see trends quickly
- Smart connectors to load probe information automatically

1551A Ex and 1552A Ex Stik Thermometer

The best substitute for precision mercury-filled glass thermometers.

- Accuracy of $\pm 0.05\text{ }^{\circ}\text{C}$ ($\pm 0.09\text{ }^{\circ}\text{F}$) over full range
- Intrinsically safe (ATEX and IECEx compliant)
- Two models to choose from ($-50\text{ }^{\circ}\text{C}$ to $160\text{ }^{\circ}\text{C}$ or $-80\text{ }^{\circ}\text{C}$ to $300\text{ }^{\circ}\text{C}$)

1620A Digital Thermometer-Hygrometer

The most accurate temperature and humidity graphical data logger on the market.

- Superior accuracy
- Network enabled
- Powerful logging and analysis tools



1620A

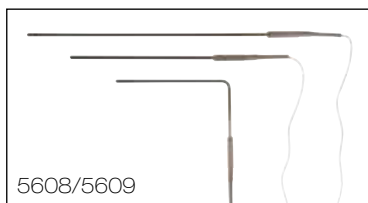

5608/5609



5626/5628

Secondary standard PRTs

5608/5609 Secondary PRTs

Very stable thermometer from -200 °C to 670 °C.

- 5608: -200 °C to 500 °C (80 mm minimum immersion)
- 5609: -200 °C to 670 °C (100 mm minimum immersion)
- Calibration not included, NVLAP-accredited calibration optional, lab code 200348-0

5615 Secondary PRT

Reference-grade platinum sensing element.

- -200 °C to 420 °C
- ± 0.012 °C accuracy at 0 °C
- Drift of ± 0.007 °C after 100 hours at max temperature

5626/5628 Secondary SPRT, PRT, Temperature Sensors

High-temperature secondary standards.

- -200 °C to 661 °C
- Meets all ITS-90 requirements for resistance ratios
- Rtp drift < 20 mK after 500 hours at 661°C

Thermistor standards

5640 Series Thermistor Standards Probes

High accuracy temperature probes with excellent stability.

- Accuracy to ± 0.001 °C
- Affordable system accuracy to ± 0.004 °C or better
- NIST-traceable calibration included from manufacturer



5615

High temperature PRT

5624 Platinum Resistance Thermometer

Precision PRT accuracy at thermocouple temperatures.

- Temperature range of 0 °C to 1000 °C
- Accuracy of ± 0.05 °C to 962 °C (includes short-term stability and calibration uncertainty)
- Long-term drift of 0.01 °C at 0 °C after 100 hours at 1000 °C

Thermocouple standards

5649/5650 Type R and Type S Thermocouple Standards

Eight models to fit any type R or S thermocouple applications.

- 0 °C to 1450 °C
- Two sizes available, each with or without reference junction
- Optional fixed-point calibration, uncalibrated accuracy is the greater of ± 0.6 °C or ± 0.1 % of reading

Precision industrial PRTs

5627A Precision Industrial PRTs

Durable PRTs with temperature range to 420 °C and accuracy to 0.025 °C.

- Vibration and shock resistant
- NVLAP-accredited calibration included, lab code 200706-0



5640

Fast response PRTs

5622 Fast Response PRTs

Designed for temperature measurements requiring fast response or short immersion over a wide range.

- Time constants as fast as 0.4 seconds
- Available as DIN/IEC Class A PRTs or with NVLAP-accredited calibration, lab code 200348-0
- Small probe diameters ranging from 0.5 mm to 3.2 mm

Small diameter industrial PRTs

5618B Small Diameter Industrial RTD

Secondary level performance with full ITS-90 calibration.

- Small diameter sheath, 3.2 mm (0.125 in)
- Excellent stability
- Includes ITS-90 coefficients

Full immersion PRTs

5606 Full Immersion PRT

PRTs for laboratory freezers, autoclaves, and furnaces.

- Transition junction designed to withstand full temperature range of probe
- 5606: -200 °C to 160 °C
- Calibration accuracy of ± 0.05 °C

Secondary thermistor probes

5610/5611/5611T/5665 Secondary Reference Thermistor Probes

Lab-grade thermistors probes for accurate work across a narrow temperature range.

- Short-term accuracy to ± 0.01 °C; one-year drift < ± 0.01 °C
- Accredited NVLAP calibration optional
- Flexible Teflon and silicone coated fast-response models

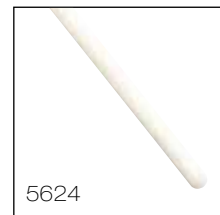

5622

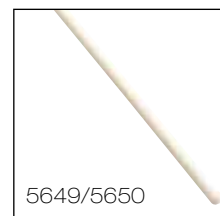

5649/5650



5627A

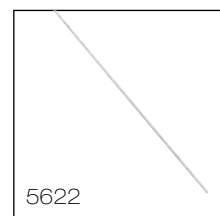

5622



5618B



5606



5610/5611/
5611T/5665



6330/7320/7340/7380



6331/7321/7341/7381



7312



6020/6022/6024



6050H



7008/7040/7037/7012/7011



6332A/7342A



7080

Compact calibration baths

6332A/7342A Temperature Calibration Baths

Fast, 0.01 °C stability baths backed by Fluke metrology, with a deep tank for calibrating PRTs and liquid-in-glass thermometers.

- Wide temperature range
 - 6332A: 50 °C to 300 °C
 - 7342A: -40 °C to 150 °C
- Stability 0.01 °C
- Uniformity (working area)
 - 6332A: 0.015 °C (50 °C to 200 °C), 0.02 °C (201 °C to 300 °C)
 - 7342A: 0.01 °C (full range)

Note: The 6332A/7342A baths are not for sale in Europe.

6330/7320/7340/7380 Compact Temperature Calibration Baths

Compact baths with the stability and uniformity required for thermometer calibration.

- Stability and uniformity each better than ± 0.008 °C
- Metrology-level performance in lab-friendly sizes
- Convenient use on benchtops or on matching carts

6331/7321/7341/7381 Deep-Well Compact Baths

Ample immersion depth and great stability, in a high value compact bath.

- 457 mm (18 in) of depth with just 15.9 liters (4.2 gal) of fluid
- Perfect for liquid-in-glass thermometers with optional LIG kit
- Fast, quiet, compact (yet deep), and economical

7312 Triple Point of Water Maintenance Bath

Keep your cells up and running reliably for weeks at a time.

- Maintains TPW cells for up to six weeks
- Optional immersion freezer for simple cell freezing
- Independent cutout circuit protects cells from breaking

Standard calibration baths

6020/6022/6024 High Temperature Calibration Oil Baths

Stable, uniform heat sources for calibrations up to 300 °C.

- Stability as good as 0.001°C
- Large-capacity tanks for higher productivity
- Built-in cooling coils for external cooling sources

6050H Extremely High Temperature Calibration Salt Bath

Designed for high-temperature calibration—up to 550 °C.

- Eliminates messy sand baths
- Electronically adjustable temperature cutouts
- Stability of ± 0.008 °C at 550 °C

7008/7040/ 7037/ 7012/7011 Cold Temperature Calibration Baths

High stability means low calibration uncertainties—no other bath performs this well.

- Stability to ± 0.0007 °C
- Best digital temperature controller available
- Super Tweak function provides set-point resolution to 0.00003 °C

7080 Really Cold Temperature Calibration Baths

Cool to -40, -60, or -80 °C without external coolants.

- Self-contained refrigeration—no LN2 or chiller required
- Temperatures as low as -80 °C in real metrology baths
- Stability of ± 0.0025 °C at -80 °C



6054/6055



2100 and 2200



7900



7009/7108/7015



9170/9171/9172/9173



9190A



9142/9143/9144

Special application baths

6054/6055 Deep-Well Baths

Extra-deep wells for thermometry work requiring extra tank depth and ultimate stability.

- Constant liquid levels through concentric-tube design
- Special design for sighting LIG thermometers
- Depth up to 60 cm (24 in)

7009/7108/7015 Resistor Baths

Three size options for any quantity of resistors.

- Stability to $\pm 0.0007\text{ }^{\circ}\text{C}$
- Independent high- and low-temperature cutout circuit

Bath controllers

2100 and 2200 Benchtop Temperature Controllers

Most stable temperature controllers available.

- Resolution as high as $0.00018\text{ }^{\circ}\text{C}$
- RS-232 interface included for automating applications

7900 Controller for Rosemount-Designed Baths

All the features of the Fluke Calibration 2100 Controller.

- Installs easily
- Two independent over-temperature cutout circuits

Metrology Wells

9170/9171/9172/9173 Metrology Well Calibrators

Accurate enough for lab use yet rugged and portable.

- Best-performing industrial heat sources (accuracy, stability, uniformity) in the world
- $-45\text{ }^{\circ}\text{C}$ to $700\text{ }^{\circ}\text{C}$
- Immersion depth to 203 mm (8 in)
- Optional ITS-90 reference input reads PRTs to $\pm 0.006\text{ }^{\circ}\text{C}$

Field Metrology Wells

9190A Ultra-Cool Field Metrology Well

Ultra-cool dry-block calibrator with best-in-class stability.

- Wide temperature range from $-95\text{ }^{\circ}\text{C}$ to $140\text{ }^{\circ}\text{C}$
- Best-in-class stability: $\pm 0.015\text{ }^{\circ}\text{C}$ full range
- Accuracy using built-in reference thermometer readout: $\pm 0.05\text{ }^{\circ}\text{C}$ full range
- Display accuracy: $\pm 0.2\text{ }^{\circ}\text{C}$ full range

9142/9143/9144 Field Metrology Wells

Small dry wells for big field applications.

- Lightweight, portable, and fast
- Cool to $-25\text{ }^{\circ}\text{C}$ in 15 minutes and heat to $660\text{ }^{\circ}\text{C}$ in 15 minutes
- Built-in two-channel readout for PRT, RTD, thermocouple, 4–20 mA current



9103



9011



6102/7102/7103



9140



9100S/9102S



9009



6109A/7109A

Dual-block dry-well

9011 High-Accuracy Dual-Well Calibrator

Widest temperature range available in a single dry-well.

- Combined range from $-30\text{ }^{\circ}\text{C}$ to $670\text{ }^{\circ}\text{C}$, one unit—two blocks
- Two independent temperature controllers (hot and cold side)
- Stability to $\pm 0.02\text{ }^{\circ}\text{C}$

Field dry-well calibrators

9103/9140 Field Dry-Well Calibrators

Great performance in portable instruments.

- Lightweight and very portable
- Accuracy to $\pm 0.25\text{ }^{\circ}\text{C}$
- RS-232 and Interface-it software included

Portable calibration baths

6109A/7109A Portable Calibration Baths

Four times more calibration throughput and twice the accuracy of Micro-Baths and dry-block calibrators

- Calibrate up to four tri-clamp sanitary sensors at the same time
- Wide temperature ranges cover most process applications
 - 6109A: $35\text{ }^{\circ}\text{C}$ to $250\text{ }^{\circ}\text{C}$
 - 7109A: $-25\text{ }^{\circ}\text{C}$ to $140\text{ }^{\circ}\text{C}$
- Excellent display accuracy of $\pm 0.1\text{ }^{\circ}\text{C}$ provides 4:1 test uncertainty ratio for critical applications
- Stainless steel casing withstands harsh sterilizing chemicals and is rust proof
- NVLAP-accredited calibration included standard

Micro-Baths

6102/7102/7103 Micro-Bath Thermometer Calibrators

Portable and extremely stable.

- Small portable calibration baths
- Calibrates sensors of different size or shape
- Accuracy $\pm 0.25\text{ }^{\circ}\text{C}$

Handheld calibrators

9100S/9102S Handheld Dry-Well

Small, light, and portable dry-wells.

- Ranges from $-10\text{ }^{\circ}\text{C}$ to $375\text{ }^{\circ}\text{C}$
- Accuracy to $\pm 0.25\text{ }^{\circ}\text{C}$, stability of $\pm 0.05\text{ }^{\circ}\text{C}$ at $0\text{ }^{\circ}\text{C}$

9009 Industrial Dual-Block Thermometer Calibrator

Double your productivity or cut your calibration time in half.

- Temperatures from $-15\text{ }^{\circ}\text{C}$ to $350\text{ }^{\circ}\text{C}$ in one unit
- Two wells in each block for simultaneous comparison calibrations
- Rugged, lightweight, water-resistant enclosure



4180/81



9132 and 9133

Infrared calibrators

4180/81 Precision Infrared Calibrators

Accredited performance for point-and-shoot calibrations.

- Calibrated radiometrically for meaningful, consistent results
- Accredited calibration included
- Accurate, reliable performance from -15 °C to 500 °C

9132 and 9133 Portable Infrared Calibrators

Precision when you need it for infrared temperature calibration.

- Certify IR pyrometers from -30 °C to 500 °C (-22 °F to 932 °F)
- Large 57 mm (2.25 in) black-body target
- RTD reference well for contact temperature measurement

Zero-point dry-well

9101 Series Metrology Well Calibrators

Ice-point reference without the ice.

- ± 0.005 °C stability in a portable ice-point reference
- Easy re-calibration for long-term reliability
- Ready light frees user's time and attention

Surface probe calibrator

3125 Surface Probe Calibrator

Milled aluminum for a smooth and true calibration work area with maximum thermal conductivity.

- Calibrates surface sensors up to 400 °C
- Uses Fluke Calibration 2200 Controller for excellent accuracy and stability
- NIST-traceable calibration included

Thermocouple furnaces

9150 Thermocouple Furnace

Convenient, portable thermocouple furnace.

- 150 °C to 1200 °C
- Stability of ± 0.5 °C over full range
- NIST-traceable calibration included
- RS-232 port standard

9118A Thermocouple Calibration Furnace

High performance furnace for thermocouple calibrations to 1200 °C. The Fluke Calibration 9118A Thermocouple Calibration Furnace is a horizontal, open-ended tube furnace with a temperature range of 300 °C to 1200 °C.

- Wide temperature range
- Calibrates many thermocouple types
- Best-in-class temperature stability and uniformity
- Automated setpoint control



9150



9101



3125

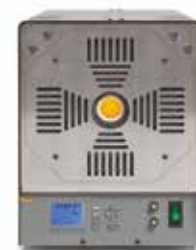

9118A



Humidity calibration

Humidity affects many properties of air and the materials that are exposed to it. Monitoring and measuring humidity is important wherever there is a need to prevent condensation, corrosion, mold, warping or spoilage of products. For example, it's important to measure humidity in industries that manufacture and distribute foods, pharmaceuticals, chemicals, fuels, wood, textiles, and paper.

The sensors that measure humidity need to be calibrated regularly to ensure they continue to operate within their specifications. Humidity sensor calibration is typically done using an instrument called a humidity generator.

Most humidity generators are based on one of two designs. A mixed-flow generator controls humidity by using the split-stream method. In this method, dry gas is drawn into the generator and divided

into two parts. One part is partially or completely saturated with water vapor; the other part is mixed in until the targeted humidity output is reached. The humidity depends on the wet air's humidity and the mixing ratio. A high-volume fan in the test chamber keeps the temperature and humidity uniform.

A two-pressure generator has two chambers. The first, called the saturator, contains air saturated with water vapor at a high pressure. The air passes from the saturator to the second chamber, called the test chamber. The test chamber is at a lower pressure. As the air passing into the test chamber reduces in pressure, its relative humidity also drops.

A mixed-flow generator is faster than a typical two-pressure generator, and is also more portable, which makes this type of calibrator a good solution for work in the lab or on-site in the field.

Product highlights



5128A RHapid-Cal Humidity Generator

Fast, portable humidity probe and logger calibration with accredited 1 % RH system accuracy

- Best-in-class system accuracy for dependable humidity probe calibration
- Rapid humidity and temperature stabilization time for high calibration throughput
- Supports on-site, multi-point calibration of humidity probes
- Versatile design accommodates a large workload
- Compact size and lightweight for easy transport
- ISO 17025 accredited system calibration included standard
- Easy to maintain.



Pressure calibration

Pressure calibration is the comparison of the output of a device used to measure pressure with that of another pressure measurement device, or pressure measurement standard. This usually involves plumbing the unit under test (UUT) to the standard device and generating a common pressure in the measurement circuit. The outputs of the devices are compared at one or more pressures, typically from the lowest to highest readings of the UUT's full scale range, or the range over which it is normally used.

The comparison process can be performed in a chain from the highest level of fundamental pressure realization down to everyday pressure measurement devices, such as analog gauges, transducers and transmitters, to ensure that pressure measurements are accurate and comply with accepted or mandated standards.

The test fluid inside a pressure calibration system may be liquid or gas depending on the application. In general, gas (usually compressed nitrogen or air) is used for cleanliness and precision at lower pressures, and liquids (usually oil or water) are often used for safety, leak integrity, and ease of pressure generation at higher pressures above 7 MPa to 40 MPa (1,000 psi to 6,000 psi). There is a great deal of overlap in the actual ranges for which liquid or gas may be used practically, as reflected in the range of Fluke Calibration instruments that are specialized for each type of test fluid.

Product highlights



8270A/8370A Modular Pressure Controllers/Calibrators

Widest workload coverage in an automated high-pressure controller

The 8270A and 8370A are automated pneumatic pressure controllers that calibrate a wide workload of pressure sensors, covering twice the pressure ranges at twice the speed of other high-pressure controllers. Two models let you balance price and performance:

- The 8270A measures and controls pressures from vacuum to 44 MPa (6400 psi). It can be configured with ranges as low as 100 kPa (15 psi).
- The 8370A measures and controls pressures from atmosphere to 107 MPa (15,500 psi). It can be configured with ranges as low as 700 kPa (100 psi).

Fluke Calibration's unique control technology enables you to use these calibrators at low or high pressures, all in the same instrument. Control precision is 0.002 % of active range. Expand workload coverage to both gas and liquid filled devices by using the optional Contamination Prevention System (CPS).



6270A Modular Pressure Controller/Calibrator

Calibrate a wide range of pressure gauges and sensors with a single instrument

- Modular configuration makes this a versatile and expandable solution
- Easy to operate and maintain
- Wide measurement range—vacuum to 3000 psi (20 MPa)
- Three levels of accuracy—0.02 % FS, 0.01 % reading from 50 % to 100 % span, or 0.01 % reading from 30 % to 100 % span.—let you balance performance and budget
- High speed, stable pressure control
- Localized graphical user interface in choice of ten languages
- Can be fully automated with COMPASS® for Pressure software
- Optional contamination prevention system keeps valves clean and free from debris



2271A Industrial Pressure Calibrator

The complete pneumatic pressure calibrator that grows along with your workload for wide workload coverage now and in the future

The 2271A Industrial Pressure Calibrator provides a complete, automated solution for calibrating a wide variety of pressure gauges and sensors. Thanks to its modular design, it can be configured to meet different needs and budgets, and expanded to cover a broad workload.

- Calibrate a wide range of gauges and sensors with a single instrument
- Wide measurement range from -100 kPa to 20 MPa (-15 psi to 3,000 psi)
- Removable pressure measurement modules make it easy to change or add measurement ranges
- Integrated electrical measurement module provides a complete solution for calibrating pressure transmitters
- Built-in dual test ports enable you to connect multiple units under test (UUTs)
- 0.02 % FS pressure measurement uncertainty
- Localized graphical user interface in choice of ten languages

Selection guide

Gas Pressure Calibrators

This selection guide presents only some of the Fluke Calibration gas pressure calibration line. Other higher accuracy solutions are available for all pressure ranges.

	Manual									
	Deadweight testers									
	P3011	P3012	P3013	P3014	P3015	P3022	P3023	P3025	P3031	P3032
Workload										
Gauges/sensors										
Gage										
Bidirectional*										
Pressure range										
Vacuum										
90 % vacuum										
Positive gage pressure										
5 inH ₂ O (1.5 kPa)										
12 inH ₂ O (3 kPa)										
1.5 psi (10.3 kPa)										
2 psi (13.8 kPa)										
2.2 psi (15 kPa)										
3 psi (20.7 kPa)										
5 psi (34.4 kPa)										
10 psi (68.9 kPa)										
15 psi (103.4 kPa)										
20 psi (137.9 kPa)										
30 psi (200 kPa)										
40 psi (275.8 kPa)										
100 psi (.7 MPa)										
150 psi (1 MPa)										
200 psi (1.4 MPa)										
300 psi (2 MPa)										
500 psi (3.4 MPa)										
600 psi (4 MPa)										
1,000 psi (7 MPa)										
2,000 psi (14 MPa)										
Accessories										
Hand pump	○				○	○	○	○		
Fine Inc. Weights				○	○	○	○	○		

*Requires vacuum pump
○=Optional
0.0015 % FS
0.015 % reading uncertainty

Selection guide

Hydraulic Pressure Calibrators

This selection guide presents only some of the Fluke Calibration hydraulic pressure calibration line. Other higher accuracy solutions are available for all pressure ranges.

	Manual														Semi Automated												
	Deadweight Testers														EDWT Electronic Deadweight Tester												
	P3111	P3112	P3113	P3114	P3115	P3116	P3123	P3124	P3125	P3830	P3840	P3860	P3211	P3213	P3214	P3223	P3224	6531					6532				
																	7M	14M	20M	40M	70M	140M	200M	70M	140M	200M	
Fluid type																											
Oil																											
Water																											
Workload																											
Gauges/sensors*																											
Gage																											
Pressure range																											
10 psi (68.9 kPa)																											
15 psi (103.4 kPa)																											
20 psi (137.9 kPa)																											
30 psi (200 kPa)																											
40 psi (275.8 kPa)																											
100 psi (.7 MPa)																											
150 psi (1 MPa)																											
200 psi (1.4 MPa)																											
300 psi (2 MPa)																											
500 psi (3.4 MPa)																											
600 psi (4 MPa)																											
1,000 psi (7 MPa)																											
2,000 psi (14 MPa)																											
3,000 psi (20 MPa)																											
5,000 psi (35 MPa)																											
6,000 psi (40 MPa)																											
10,000 psi (70 MPa)																											
16,000 psi (110 Mpa)																											
20,000 psi (140 MPa)																											
30,000 psi (200 MPa)																											
40,000 psi (275.8 MPa)																											
60,000 psi (400 MPa)																											

0.015 % reading uncertainty
0.002 % full scale uncertainty
0.0015 % full scale uncertainty
0.0075 psi (0.05 kPa) uncertainty
0.0002 % span uncertainty



6270A

Gas pressure controllers/calibrators

6270A Modular Pressure Controller/Calibrator

Calibrate a wide range of pressure gauges and sensors with a single instrument

- Modular configuration makes this a versatile and expandable solution
- Wide measurement range—vacuum to 3000 psi (20 MPa)
- Three levels of accuracy—0.02 % FS, 0.01 % reading from 50 % to 100 % span, or 0.01 % reading from 30 % to 100 % span—let you balance performance and budget
- Can be fully automated with COMPASS™ for Pressure software
- Optional contamination prevention system keeps valves clean and free from debris

7252/7252i Dual Output Gas Pressure Controllers

A unique and flexible approach to performing automated calibrations over a wide pressure range.

- Two independent pressure measurement and control modules
- Two performance models available, 7252i and 7252
- Fast control: <15 seconds with zero overshoot
- Full scale ranges from 0 to 2.5 kPa and to 21 MPa (0 to 0.36 psi and to 3,000 psi)



7250LP

7250LP Low Pressure Controller/Calibrator

Specialized measurement and control for very low draft pressure range.

- Precision: 0.005 % of reading
- Control stability: 0.004 % of each range
- Resolution to 0.0001 in H₂O
- Full scale ranges from 0 to 10 in H₂O (2.5 kPa) to 0 to 100 in H₂O (25 kPa)

PPC4 Gas Pressure Controller/Calibrator

Wide rangeability and flexibility in a single controller. Ranges and accuracy classes can be selected to best suit the application.

- Up to two internal Quartz Reference Pressure Transducers (Q-RPTs) from absolute (vacuum) to 14 MPa (2000 psi)
- Full-scale standard class Q-RPTs provide 0.015 % full scale of selected range measurement uncertainty
- Standard class Q-RPTs provide 0.01 % reading measurement uncertainty
- Premium class Q-RPTs provide 0.008 % reading measurement uncertainty
- 4 ppm control precision as low as 1 kPa (0.15 psi) with large turndown
- Can use RPM4 reference pressure monitors as integrated remote pressure references for additional Q-RPT ranges



7250/7250i

7250/7250i Gas Pressure Controllers/Calibrators

Combining advanced precision, stability, speed and affordability.

- Pressure ranges from 0 to 40 kPa and to 21 MPa (0 to 5 psi and to 3000 psi, 0 to 400 mbar and to 210 bar)
- Model 7250i provides precision of 0.005 % of reading
- Model 7250 provides 0.003 % of full scale precision
- Stability: 0.0075 % of reading per year
- Time to setpoint: 15 seconds with no overshoot

2271A Industrial Pressure Calibrator

The complete pneumatic pressure calibrator that grows along with your workload for wide workload coverage now and in the future.

- Calibrate a wide range of gauges and sensors with a single instrument
- Wide measurement range from -100 kPa to 20 MPa (-15 to 3,000 psi)
- Removable pressure measurement modules make it easy to change or add measurement ranges
- Integrated electrical measurement module provides a complete solution for calibrating pressure transmitters
- Built-in dual test ports enable you to connect multiple units under test (UUTs)
- Two levels of accuracy, 0.01 % reading or 0.02 % FS
- Localized graphical user interface in choice of ten languages



7252/7252i



PPC4

7250xi High Performance Gas Pressure Controllers/Calibrators

Unmatched precision and speed.

- Pressure ranges from 0 to 40 kPa and to 17 MPa (0 to 5 psi and to 2500 psi, 0 to 400 mbar and to 170 bar)
- Advanced precision of 0.005 % of reading from 5 % to 100 % of full scale
- Stability: 0.0075 % of reading per year
- Time to setpoint: 15 seconds with no overshoot



2271A

High pressure controllers/calibrators

8270A/8370A Modular Pressure Controllers/Calibrators

Widest pressure calibration workload coverage with twice the speed of other high-pressure controllers

- 8270A covers a wide range of vacuum to 44 MPa (6300 psi). It can be configured with ranges as low as 100 kPa (15 psi).
- 8370A covers a wide range of atmosphere to 107 MPa (15000 psi). It can be configured with ranges as low as 700 kPa (100 psi).
- Three levels of accuracy, 0.02 % FS, 0.01 % reading from 50 % to 100 % of span or 0.01 % reading from 30 % to 100 % of span
- Can be fully automated with COMPASS for Pressure software
- Optional contamination prevention system keeps valves clean and free from debris

7615 Hydraulic Pressure Controller/Calibrator

Unique, high speed approach to high pressure calibration and testing.

- Ranges to 280 MPa (40 k psi)
- Measurement precision to 0.01 % of range
- Available in a variety of fluids, including water
- High speed pressure control

PPCH Hydraulic Pressure Controller/Calibrator

Wide rangeability and flexibility with precise high pressure hydraulic control.

- Ranges to 200 MPa (30 k psi)
- One or two internal Q-RPTs with large range turndown
- High precision control over wide range
- Can use RPM4 reference pressure monitors as integrated remote pressure references for additional Q-RPT ranges

Reference pressure indicators

RPM4 Reference Pressure Monitor

Premium measurement performance in a compact and rugged instrument.

- One or two independent quartz reference pressure transducer modules (Q-RPTs) with individual self-defense systems (SDS™) to prevent over-pressure
- Infinite Ranging and AutoRange™
- Differential measurement mode (channel 1- channel 2)
- Dedicated version available for air data ranges units and features, RPM4-AD
- Can be used as integrated external reference pressure transducer for PPC pressure controller/calibrators

7050 Series Digital Pressure Indicators

Unmatched precision with long term stability.

- Pressure ranges from 0 to 10 in H₂O and 0 to 1,500 psi (0 to 25 mbar and 0 to 100 bar)
- Model 7050i provides precision of 0.005 % of reading
- Model 7050 provides 0.003 % of full scale precision
- Active matrix color screen with enhanced navigation menus
- Model 7050LP provides precision of 0.005 % reading for very low draft pressure ranges



8270A/8370A



7615



PPCH



RPM4



7050



PG7601



PG7202

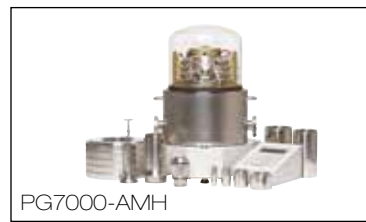

PG7000-AMH



PG7102



PG7302



2465A

Piston gauges

PG7601 Absolute Gas Piston Gauge

Gas piston gauge with vacuum reference for defining absolute pressures.

- Gas pressure from 5 kPa to 7 MPa (0.7 psi to 1,000 psi) gauge or absolute pressure
- Onboard measurement of test conditions, and real-time calculation and display of test pressure
- Compatible with PPC4 pressure controller and AMH-38 Automated Mass Handler

PG7102 Gas Piston Gauge

Gas piston gauge with 55 kg mass set for extended range measurement of gauge pressures.

- Gas pressures from 100 kPa to 11 MPa (15 to 1,600 psig)
- Onboard measurement of test conditions, and real-time calculation and display of test pressure
- Compatible with PPC4 pressure controller and AMH-100 Automated Mass Handler

PG7202 High Pressure Gas Piston Gauge

Gas piston gauge with oil-lubricated piston-cylinder for operation in high pressure gas or oil.

- Gas pressures from 100 kPa to 110 MPa (15 to 16,000 psig), oil pressures from 100 kPa to 200 MPa (15 to 30,000 psig)
- Gas operated, liquid lubricated for robust operation and low piston sink rates
- Onboard measurement of test conditions, and real-time calculation and display of test pressure
- Compatible with 8370A pressure controller and AMH-100 Automated Mass Handler

PG7302 Piston Gauge

Oil piston gauge for measurement of high gauge pressures.

- Oil pressures from 100 kPa to 500 MPa (15 psi to 75,000 psig)
- Onboard measurement of test conditions, and real-time calculation and display of test pressure
- Compatible with PPCH pressure controller and AMH-100 Automated Mass Handler

PG7000-AMH Automated Mass Handler

Automated Mass Handler for PG7000 Piston Gauges.

- Add to PG7000 Series piston gauge to fully automate pressure testing in gauge or absolute mode
- Designed and tested to provide years of reliable, maintenance free operation
- Reduce wear and possible mass value changes caused by manual mass handling

2465A Absolute Gas Piston Gauge

Gas piston gauge capable of very low pressures, for defining gauge and absolute pressures.

- Gas pressure from 1.5 kPa to 7 MPa (0.2 psi to 1000 psi) gauge or absolute pressure
- Lightweight, compact system with small masses for reduced bench space, transportability and ergonomic mass handling
- Compatible with WinPrompt and COMPASS software



PG9607/ PG9602



3990



GPC1

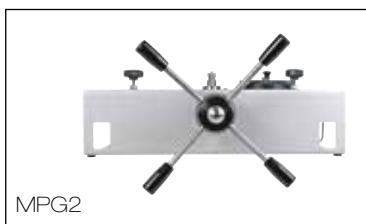

MPG2



OPG1



700HPPK

National Metrology Institute piston gauges

PG9607 Gas Piston Gauge

Fully automated primary pressure reference for absolute and gauge pressures to 500 kPa.

- Gauge and absolute pressures from 11 kPa to 500 kPa with a single piston-cylinder
- Large diameter 50 mm piston-cylinder with improved geometry allows direct traceability to dimensional measurements with very low uncertainties

PG9602 Gas Piston Gauge

Fully automated primary pressure reference for absolute and gauge pressures to 11 MPa.

- Gauge and absolute pressures from 10 kPa to 11 MPa
- Up to 100 kg mass load under vacuum bell jar for large turndown and overlap of piston-cylinder ranges

Manual pressure generation and control

3990 Gas Pressure Control Pack

Precise, manual absolute and gauge pressure control for gas piston gauges and indicators.

- Models from vacuum to 7 MPa and 20 MPa (1,000 psi and 3,000 psi)
- Self-contained for intuitive, easy use

GPC1 High Gas Pressure Controller

Precise, assisted manual control for high pressure gas piston gauges and indicators.

- Models to 70 MPa and 110 MPa (10 k psi and 16 k psi)
- Precise control to full pressure with simple, ergonomic push-button operation

MPG2 Hydraulic Pressure Generator/Controller

Precise, manual control for hydraulic piston gauges and indicators.

- Models to 100 MPa and 200 MPa (15 k psi and 30 k psi)
- Self-contained for intuitive and easy generation and precise control to full pressure

OPG1 Hydraulic Pressure Generator/Controller

Precise, assisted manual control for hydraulic piston gauges and indicators.

- Pressure to 200 MPa (30 k psi)
- Precise generation and control to full pressure with simple, ergonomic push-button

700HPPK Pneumatic Test Pump Kit

Generate 21 MPa (3,000 psi) easily in the field, without liquid contamination or the hazard of a pressurized gas cylinder

- Generate and adjust pneumatic pressures up to 21 MPa (3,000 psi)
- Rugged, portable and stable enough to go anywhere—on any surface
- Reaches pressure in 20 seconds to full scale into a 30 cm³ volume
- Detachable pressure adjustment system for adjusting pressure, connecting reference and test devices on bench and in the field, and isolating and venting pressure



P3000

Industrial deadweight testers



P3100



P3200



P3800



P5510



P5513



P5514



P5515

P3000 Pneumatic Deadweight Tester

High performance gas deadweight testers, with unique suspended piston design for vacuum calibration.

- 0.015 % of reading accuracy standard (0.008 % optional)
- 3 to 500 psi (0.2 to 35 bar) pressure
- Optional low range 0.03 to 1 bar vacuum (1 to 30 inHg)
- Integrated vacuum and pressure pump available to 2 MPa (300 psi)

P3100 Hydraulic Deadweight Tester

Highly accurate oil deadweight tester, with quick and easy-to-use single and dual piston deadweight models.

- Pressure ranges to 140 MPa (20 k psi, 1400 bar)
- 0.015 % of reading accuracy standard (0.008 % optional)
- Built-in pressure generation and adjustment
- Single or dual piston formats

P3200 Hydraulic Deadweight Tester

Hydraulic deadweight tester specially designed to use water as a test medium.

- Pressure ranges to 70 MPa (10 k psi, 700 bar)
- 0.015 % of reading accuracy standard (0.008 % optional)
- Built-in pressure generation and adjustment is standard
- Single or dual piston formats
- Water media

P3800 Hydraulic Deadweight Tester

High performance and simplicity for very high pressure hydraulic calibration.

- Pressure ranges to 400 MPa (60 k psi, 4,000 bar)
- 0.02 % of reading accuracy standard (0.015 % optional)
- Includes hand pump and intensifier for generating and adjusting high pressures

Pressure comparators

P5510 Pneumatic Pressure Comparator*

Precise, cost effective solution for checking pressure measuring instruments to 300 psi (20 bar).

- Dual pressure/vacuum capability
- Pressure to 21 MPa (300 psi, 20 bar)
- Vacuum from 0 to 80 kPa (0 to 24 inHg, 800 mbar)
- Built-in pressure and vacuum generation

P5513 Pneumatic Pressure Comparator*

Precise, cost effective solution for checking pressure measuring instruments to 3,000 psi (210 bar).

- Pressure range 0 to 21 MPa (3 k psi, 210 bar)
- High pressure pneumatic operation
- Screw press for fine pressure adjustments
- High quality needle valves for fine control

P5514 and P5515 Series Hydraulic Pressure Comparators*

Quick and easy solutions for checking pressure measuring instruments to 10,000 psi (700 bar).

- Compatible with a wide range of fluids
- P5514 Test Pump generates pressures to 70 MPa (10 k psi, 700 bar)
- P5515 Test Pump generates pressures to 140 MPa (20 k psi, 1,400 bar)
- P5515 has a built-in hand pump for system priming and large volume applications



P5514 with 2700G

* Can be used with the 2700G Reference Pressure Gauge to provide a complete calibration solution

Pressure calibrators

4322 Automated Pressure Calibrator

- Rugged, lightweight, compact components for use on the bench or in-situ
- Precise automated pressure control from vacuum to 70 MPa gauge (10,000 psi)
- Greater of 0.1 % of reading or 25 Pa (0.004 psi, 0.1 in H₂O) accuracy across the entire pressure range
- Onboard pressure/vacuum generation from 3.5 kPa (0.5 psi) absolute to 2 MPa (300 psi)

3130 Portable Pressure Calibrator

Everything you need to generate, control and measure pressure, as well as read the output of the unit under test (UUT).

- Measure and generate pressures from vacuum to 2 MPa (300 psi, 20 bar)
- Internal pump can generate vacuum to -80 kPa (-12 psi, -0.8 bar) or pressure to 2 MPa (300 psi, 20 bar)
- Supply pressure connection allowing the use of external gas supply up to 2 MPa (300 psi, 20 bar)
- Includes variable volume for fine adjustment of pressures
- Pressure measurement accuracy of 0.025 % reading \pm 0.01 % FS
- Electrical measurement and 24 volt supply for close looped calibrations
- Measure or generate 4 mA to 20 mA
- Measure 0 to 30 V dc
- Powered by internal, rechargeable, high capacity NiMH battery or universal ac mains adapter
- Compatible with Fluke 700P Pressure Modules

E-DWT-H Electronic Deadweight Tester

A digital alternative to the traditional deadweight tester.

- Set and measure pressure precisely without limitation of mass loading resolution
- Pressure measurement is insensitive to local gravity and orientation
- One year uncertainty of \pm 0.02 % of reading
- Run onboard test routines and store calibration data for review and export to a PC

2700G Series Reference Pressure Gauges

Best-in-class measurement performance in a rugged, easy-to-use, economical package.

- Precision pressure measurement from 100 kPa (15 psi) to 70 MPa (10,000 psi)
- Accuracy to 0.02 % of full scale
- Easy-to-use, rugged construction for reliable performance
- Combine with the 700PTPK or 700HTPK pump kits for a complete portable pressure testing solution for up to 4 MPa (600 psi) with the PTP-1 pneumatic pump and up to 70 MPa (10,000 psi) with the HTP-2 hydraulic pump
- Combine with the P5510, P5513, P5514, or P5515 Pressure Comparators for a complete bench top pressure calibration solution
- Test port is 1/4 NPT Male. 1/4 BSP and M20 X 1.5 adapters are included standard
- USB communications cable and universal power supply included standard



4322



3130



E-DWT-H



2700G



7750i

Air data calibration

7750i Air Data Calibrator

Air data test set with unequalled precision and long term stability and superior pressure control technology.

- High accuracy, RVSM compliant
- Accuracy to ± 2 feet, 0.02 knots
- True differential sensor for airspeed (Qc)



RPM4-AD

RPM4-AD Reference Pressure Monitor

Specialized pressure indicator for the absolute and differential pressure ranges in air data instruments.

- Fixed wing and rotary wing range versions
- True Pt, Ps, Qc operation



2468A

2468A Pitot/Static Primary Standard

Gas piston gauge specialized for air data absolute and differential pressure ranges.

- Pressure range: 0.4 inHg to 103 inHg
- Optional range: 3.4 inHg to 400 inHg
- Accuracy to ± 0.5 feet, 0.003 knots
- Extended mass set covers entire air data range without the need to change pistons
- Compatible with WinPrompt and COMPASS software



7250sys

Pressure calibration systems

7250sys Multi-Range Pressure Calibration System

Turn-key automated gas pressure calibration system.

- Gas pressure measurement and control from low absolute to 17 MPa (2500 psi)
- Fully integrated multi-range pressure test and calibration systems with a single interface and single test port
- Select either an 8 range or the 12 range system for maximum performance and coverage

Custom Pressure Calibration Systems

Engineered custom systems integrate standard Fluke Calibration products into a complete system based on the user's specific requirements. These are often multi-range systems that include pressure generation and supply accessories, data acquisition hardware and software and/or test instrument connection manifolds. Custom systems include but are not limited to turn-key pressure calibration rack systems, portable calibration carts and automated pressure calibration bench systems.



Gas flow calibration

What is gas flow calibration?

Gas flow calibration refers to the calibration of a flow sensing device such as a flow meter or flow controller by comparing its measurement against a flow measurement reference. Typically, the device, or unit under test (UUT), is pneumatically connected in series with the flow reference so they measure the same gas flow; then the indications of the two devices are compared.

molbloc™/molbox™ system components

Fluke Calibration's molbloc/molbox gas flow calibration system consists of molbloc flow elements that connect to a flow terminal (either molbox1+ or molbox RFM) so the terminal can use pressure and temperature measurements from around the flow element, combined with gas properties and prior molbloc calibration data, to determine and display the gas flow rate.

Mass flow vs. volume flow

A frequent topic of discussion and confusion surrounding gas flow measurement is that of mass flow versus volume flow. Flow meters and flow units used for flow measurements are used to measure and express either the amount of volume of gas or the amount of mass (number of moles or molecules) passing through the device. When performing a gas flow calibration, it is nearly always beneficial to use a mass flow reference measurement, because the mass flow rate stays constant throughout a flow system in steady state. Since gas is compressible, the volume flow rate varies at different locations in a flow system due to changes in density caused by changing temperature and pressure. Fluke Calibration molblobs are mass flow standards, which allow reliable comparisons to other flow devices. The molbox terminal is also able to calculate and express the flow rate in terms of volume flow at another point in the system to allow testing of volume-based devices.



molbox1+



molboc-L



molboc-S



molbox RFM

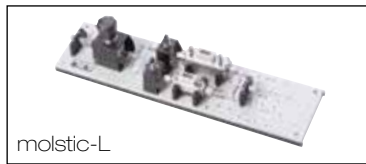

molstic-L



molstic-S



MFC-CB™



MFC Switchbox

Gas flow standards

molbox1+ Flow Terminal

0.125 % of reading—lowest uncertainty for gas flow calibration.

- Allows coverage of flow range from less than 1 sccm to over 5000 slm with a single user interface and transportable system
- Real-time flow measurements makes adjusting analog flow devices fast and easy
- Perform fully-automated flow calibrations using molbox terminal with COMPASS for Flow software
- Updated design

molboc-L Laminar Flow Element

Laminar flow elements for flow from 1 sccm to 100 slm.

- Traceable to primary gravimetric mass flow measurements
- Multiple gases supported
- Useable with existing molbox1+ and molbox RFM mass flow terminals and COMPASS software
- Integrated filter to protect against contamination
- Integral gas temperature conditioning and measurement
- No moving parts that cause pressure/flow fluctuations or threaten reliability

molboc-S Sonic Nozzle Flow Element

Sonic nozzle based molblocs for gas flow up to 5,000 slm.

- Covers ranges up to 5,000 slm in N₂ and air
- Multiple gases supported
- Useable with molbox1+, or existing molbox1 and molbox RFM mass flow terminals and COMPASS software
- Proven critical flow venturi (sonic) nozzle operating principle traceable to primary gravimetric flow measurements

molbox RFM Reference Flow Monitor

Compact terminal for making mass flow measurements using molboc-L and molboc-S flow elements.

- Economical alternative to molbox1+ terminal
- ± 0.5 % of reading uncertainty
- Covers the flow range of 1 sccm to 100 slm with molboc-L, and up to 5,000 slm with molboc-S
- 5141/5142/5144 kits feature molbox RFM, molboc-L and other hardware for a complete calibration system
- No moving parts that cause pressure/flow fluctuations or threaten reliability

molstic Mounting Systems

Used to conveniently mount and protect molboc elements, connect to units under test and provide flow and pressure control.

molstic-L used for molboc-L mass flow elements.

- Quick connector input
- 2 micron (0.5 micron for low flow) filter to protect the downstream components
- Adjustable regulator protects the molbox transducers

molstic-S used for molboc-S mass flow elements.

- Available in 1/2 inch or 1/4 inch system plumbing sizes
- Integrated flow shut-off/metering valves

Gas Flow Automation Accessories

MFC-CB™ Control Box

Stand-alone unit for setting/reading analog mass flow controllers (MFCs) and mass flow meters (MFMs).

- Set and read 0 to 5 V or 4 to 20 mA on two (2) channels
- Complete front panel local control and remote operation via RS-232 and IEEE-488 interfaces

MFC Switchbox™

Supplies power and switches between up to five MFCs or MFMs on one molbox1+ or MFC-CB channel.

- Duplicates MFC channel without switching cables



Calibration software

Calibration software automates all or part of a calibration process via computer control. Calibration software also allows users to manage their calibration and asset data.

If you've heard about the benefits of automated calibration and asset management but are puzzled about how everything fits together, call on Fluke Calibration for solutions.

Other types of calibration software from Fluke Calibration include data-logging software, software that generates calibration constants and references, and various add-on and plug-in software programs.

Why use calibration software?

Using software to automate all or part of the calibration process offers several important advantages.

Consistency—Software automation ensures that calibrations can be performed exactly the same way by multiple operators in multiple locations. This improves the quality of results, reduces errors and standardizes methods.

Efficiency—Automating the calibration process allows technicians to set up tests and then go on to perform other tasks, making more efficient use of their time. Calibrations are typically completed much more quickly, saving time and money. If the software is capable of calibrating multiple units under test simultaneously, automation increases throughput as well.

Documentation and reports—Calibration automation software typically includes features for documenting calibration procedures, storing calibration data, and producing reports, allowing users to eliminate paper records or spreadsheets.

Because Fluke Calibration software does such a good job of keeping accurate records of all parts of the calibration process, it also supports compliance with a wide variety of quality standards.

Product highlights



MET/TEAM™ Test Equipment Asset Management Software

MET/TEAM software is a powerful, flexible, and scalable calibration management software solution for managing your calibration assets. Designed by metrologists for metrology, it is ideal for calibration professionals who need to manage workflow through the calibration laboratory.

- Browser-based software enables access that is convenient, yet secure
- Fully featured for tracking and managing assets
- Fully integrated with the Run Time function of industry leading MET/CAL software
- Replaces MET/TRACK as the recommended data- base engine for MET/CAL software
- Popular Microsoft SQL server database for reliable, affordable, non-proprietary data storage
- Workflow management
- Highly customizable fields and labels
- Shortcuts (quick links) for easy navigation
- Promotes quality processes to support accreditation
- Customizable reports with Crystal Reports Professional
- Automated email alerts and recall escalation
- Mobile module for on-site calibration
- Customer web portal to allow read-only access for remote customers
- Commerce module for quoting, billing, and contract pricing
- Designed for metrology by metrologists
- Backed by Fluke Calibration, expert in calibration instrumentation and software
- Collect and store manual calibration data



MET/CAL™ Calibration Management Software

MET/CAL software automates the calibration process to help you manage your workload more efficiently and consistently. The MET/CAL suite of applications includes MET/CAL software, the industry leader for automated calibration; plus MET/TEAM software for asset management.

An updated Runtime interface offers better visibility into the calibration process. An updated Procedure Editor interface lets users view test results in a graphical user interface.

MET/CAL software provides you with the tools you need to:

- Perform automated calibration on all kinds of test and measurement tools and equipment, including dc/lf, RF and microwave instruments
- Create, edit, test, and document calibration procedures, quickly and easily
- Configure and report a wider range of measurement uncertainty parameters and include verification data to provide an audit trail and support further analysis
- Track asset information including calibration and maintenance history and status, traceability, users, customers, and location
- Analyze and report asset information; produce customized printed certificates and reports.
- Make data available to other corporate systems
- Import asset and calibration data into MET/CAL software
- Help meet the requirements of quality standards like ISO 9000, ISO/IEC 17025, NRC 10 CFR, ANSI Z540.3, and others

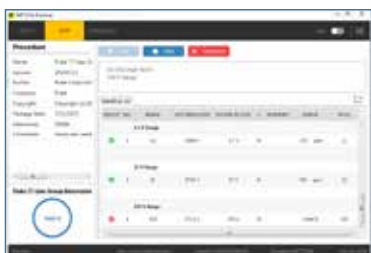

MET/CAL

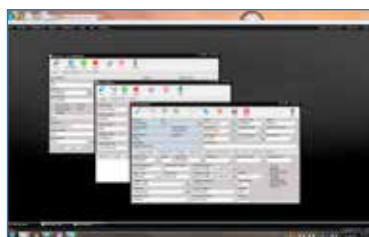

MET/TEAM



MET/SUPPORT

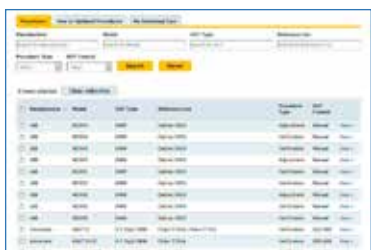

Warranted Procedures for MET/CAL

Calibration asset management software

MET/TEAM Test Equipment Asset Management Software

Manage more workload with less work with MET/TEAM software.

- Browser-based calibration asset management software
- Fully integrated with MET/CAL Software
- Microsoft SQL Server database
- Highly customizable
- Email automation
- On-site calibration
- Work flow management
- Pricing/billing/invoicing
- Customer web portal
- Installation and training services

Electrical/RF calibration software

MET/CAL™

The complete solution for automating calibration processes plus managing and reporting measurement assets.

- Perform fast, repeatable, and powerful calibration
- Full storage of calibration data
- Rich reporting capabilities
- Configure and report a wider range of measurement uncertainty parameters

Warranted Procedures for MET/CAL

Fully tested, ready-to-go procedures designed to satisfy your needs.

- Optional calibration procedures for MET/CAL Calibration Software
- Warranted by Fluke Calibration to produce valid calibrations on the intended unit under test (UUT) for the specified model and revision level
- These procedures automate the calibration process under MET/CAL control

Software support programs

MET/SUPPORTSM Gold

Annual support programs for MET/CAL and MET/TEAM software. These premier support services help you maximize your software investment.

- Premium support and services to help you maximize productivity with MET/CAL and MET/TEAM software
- Access to warranted procedure library
- Prioritized technical support
- Software updates and upgrades
- Priority web content
- Discounts on a variety of services

Software Training and Services

A range of services to help you maximize your investment in calibration software.

- MET/TEAM software installation and startup
- MET/TEAM data migration and import
- Classroom or onsite training classes:
 - MET/CAL procedure writing
 - Advanced procedure writing
 - MET/TEAM Asset Management
 - Crystal Reports Writing
- Custom MET/CAL procedures
- MET/TEAM self-validation
- Custom software services

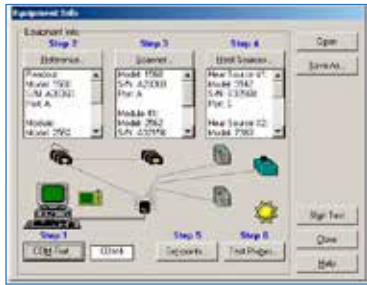

9938 MET/TEMP II Temperature Calibration Software v5

Temperature calibration software

9938 MET/TEMP II Temperature Calibration Software v5

New version of the proven solution for automated temperature calibration

- Compatible with Windows 7 and 8 operating systems
- Adds support for 9190A Field Metrology Well and 9118A Thermocouple Furnace
- Calibrate PRTs, SPRTs, thermistors, thermocouples, and even liquid-in-glass (LIGs), bi-metallic thermometers, and connected sensors that can't be attached to a readout
- Supports multiple temperature sources and reference probes in the same test for faster calibration and extended test range

TQSoft and TQAero Thermal Validation Software

For FDA 21 CFR Part 11 and AMS 2750 Compliant Data Collection

- Support for Fluke 2638A and 1586A, for enhanced data collection and reporting in regulated industries
- Easy menu system and toolbar
- Test equipment preparation and sensor calibration
- Data security, audit trail, and compliance reports

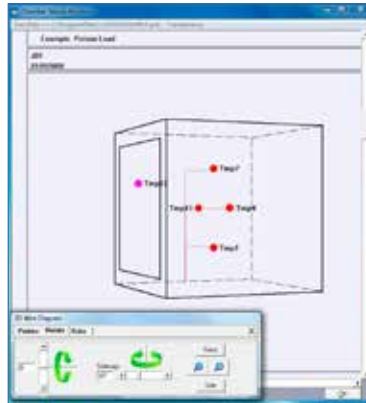

TQSoft and TQAero Thermal Validation Software

LogWare

Turn a Fluke Calibration single-channel handheld or 1502A/1504 readout into a real-time data logger.

- Collects real-time data
- Calculates statistics and displays customizable graphs
- Allows user-selected start times, stop times and sample intervals

LogWare II

Turn any Fluke Calibration multi-channel thermometer readout into a real-time data logger.

- Collects real-time data using Fluke Calibration multi-channel readouts
- Calculates statistics and displays customizable graphs
- Allows user-selected start times, stop times and sample intervals

LogWare III

Remotely monitor and log a virtually unlimited number of concurrent log sessions into a central data repository.

- Up to two temperature and two humidity inputs for each DewK
- Customize your graph trace color, alarms, and statistics as you go

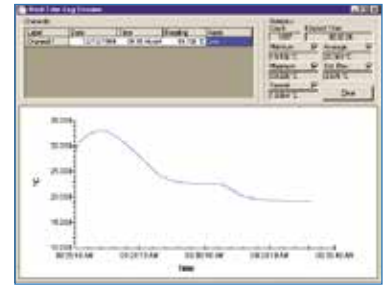

LogWare



LogWare II



LogWare III

Test No.	Test Description	Test Type	Test Value	Units	Low Limit	High Limit	Resolution	Units	Uncertainty
1	General	Blank Label							
2	General	Check / Flush are OK							
3	Span	W	1.25 and 2.47						
4	Span	W	Reading Reference						
5	Span	Blank Line							
6	Performance Test	Blank Label							
7	Spanning Accuracy		11.00	psi	10.00	12.00	0.10	0.10	0.10
8	Spanning Accuracy		6.50	psi	6.00	7.00	0.10	0.10	0.10
9	Spanning Accuracy		11.50	psi	11.00	12.00	0.10	0.10	0.10
10	Performance Test	Blank Line							
11	Spanning Accuracy	Span Test							

COMPASS for Pressure



COMPASS for Pressure

Pressure/Flow calibration software

COMPASS™ for Pressure

Universal platform for automating pressure calibration.

- Integrated piston gauge support
- Runs complete automated calibration sequences
- Supports multiple units under test
- Automates virtually any pressure standard or device under test

COMPASS for Flow

Macro-enabled mass flow calibration software package.

- Fully customizable
- Supports non Fluke Calibration flow references
- Performs complex real time flow computations, and allows you to alter test scenarios based on data collected

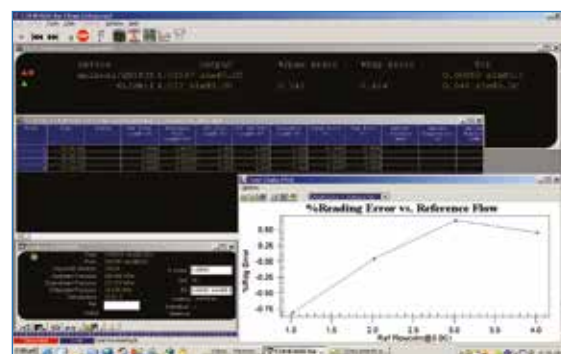

COMPASS for Flow



Data acquisition and general purpose test equipment

Data acquisition equipment

Get the data you want, where, how and when you want it. Fluke gives you a broad choice in data acquisition for process monitoring and laboratory test systems. You can choose a stationary or portable data logger. Transfer data to internal memory, to a removable memory card, or to your PC. Choose a standalone or distributed networked units. And you can expand your system from 20 to 1,000+ channels, depending on the series.

All Fluke data acquisition products feature unique, built-in universal signal conditioning and a plug-in Universal Input Module to enable you to measure virtually any type of signal without having to purchase extra equipment. Plus, powerful, easy-to-use Windows®-based software supports easy configuration, advanced trend analysis, professional-quality reporting, and enables you to quickly build human-machine-interfaces without any programming.

General purpose test equipment

Fluke Calibration designs and manufactures bench instruments in a wide variety of product categories. Besides their use on the bench, these instruments have several characteristics in common as you will find below:

- Each bench instrument is accurate and provides precise information. They reflect the professionalism of the people who buy and use them.
- Each is reliable, dependable, and rugged.
- All are easy to operate. Many owners of Fluke bench instruments say that the controls are intuitive and help them work more efficiently.
- These bench instruments are compact and easily transported, but they are also multi-functional.
- You will find that these instruments are a good value, particularly when compared against other tools for their cost/function ratio.

Product highlights



2638A Hydra Series III Data Acquisition System

A price performance breakthrough in standalone data acquisition system

The Fluke Hydra Series III continues the Hydra Series legacy in data acquisition. This new Hydra Series improves on the long standing, industry leading specification of best-in-class thermocouple accuracy. With basic dc measurement accuracy of 0.0024 %, 0.5 °C thermocouple accuracy, color trend display, easy-to-use menu system and world-class industrial safety ratings, the 2638A is a truly industrial grade, precision data acquisition system.

Expandable from 22 to 66 channels of analog differential measurement, the Hydra 2638A offers the flexibility of our Universal Input Connector, which allows quick connect and disconnect of any type of input to any channel. AC and dc voltage, resistance, thermocouple, RTD, thermistor, frequency and dc and ac current are all selectable inputs for the 2638A. If your measurement need is from under twenty channels to over sixty-six channels per unit or thousands of channels per system, we have you covered.

- DC accuracy of 0.0024 %
- Best-in-class thermocouple accuracy of 0.5 °C
- Up to 67 universal differential, isolated inputs
- On-screen color trend graphing
- Easy menu system for setup and data management
- Multi-channel real-time data display
- 6.5 digit DMM function selections
- Monitor function for real-time viewing and charting between scans
- 20 on-board separate math channels
- 45 channels/sec basic dc scan rate
- Internal 75,000 scan memory plus USB drive port
- Data security features
- CAT II 300 V input safety rated

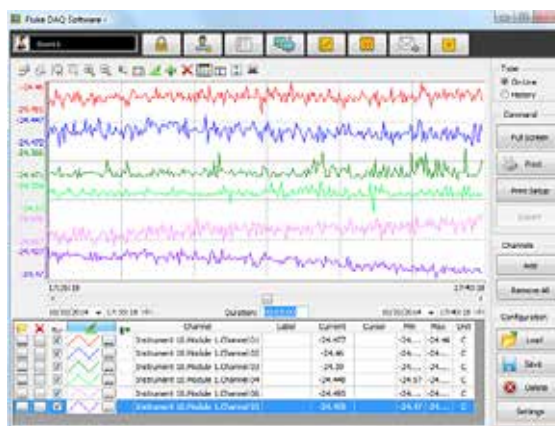

Fluke DAQ 6.0 Application Software

A powerful and versatile application for quick and easy configuration, data logging and analysis using Fluke data acquisition products

Fluke DAQ is praised by users for its versatile handling of data acquisition and logging. Improved trending, file handling, added web interface, web control, convenient print functions for charts and graphs and multiple language improvements make Fluke DAQ version 6 a feature-rich application that you can trust with your important data and analysis needs.

Fluke DAQ features easy multi-unit configuration, data logging and analysis for any of these products:

- 2638A Hydra Series III Data Acquisition System/Digital Multimeter
- 1586A Super-DAQ Precision Temperature Scanner
- 2640A and 2645A NetDAQ® Networked Data Acquisition Units
- 2680 Series Data Acquisition Systems



2638A



2686A

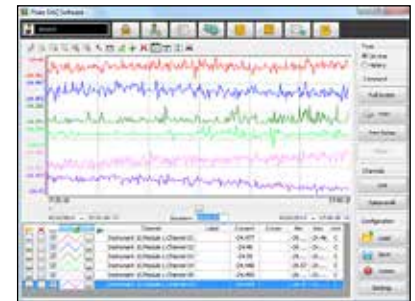

Fluke DAQ 6.0

Data acquisition equipment

2638A Hydra Series III Data Acquisition System/DMM

A price performance breakthrough in standalone data acquisition system.

- DC accuracy of 0.0024 %
- Best-in-class thermocouple accuracy of 0.5 °C
- Up to 67 universal differential, isolated inputs
- On screen color trend graphing
- Easy menu system for setup and data management
- 6.5 digit DMM function selections
- Monitor function for real-time viewing and charting between scans
- 20 on-board separate math channels
- 45 channels/sec basic dc scan rate
- Internal 75,000 scan memory plus USB drive port
- Expands to thousands of channels with application software
- Data security features
- USB flash drive support for data transfer to PC
- CAT II 300 V input safety rated

2680 Series Data Acquisition Systems

Standalone or networked precision multi-channel data acquisition

- 20 to 120 universal analog inputs per chassis; systems to +2,000 channels
- Stand-alone data logger operation with the 2686A
- Large scalable LAN systems using the 2680A with 10BaseT/100BaseT
- Two types of Universal Input Modules: high-isolation precision modules or fast scan modules, with 16- to 18-bit resolution
- Throughput of more than 3,000 channels-per-second-per-chassis with 2680A-FAI modules
- Superior thermocouple measurement accuracy (J, K, R, S, T, N, I, U, C, B)
- 20 digital I/O and 8 form C, 1 Amp relay output modules for direct control of equipment
- Up to 300 V input isolation, 1600 V transient overvoltage protection (2680A-PAI)
- Universal input conditioning for any input, on any channel, in any combination (V dc, V ac, Ohms, frequency, RTD, thermocouple, thermistor or current)
- ATA flash memory card for stand-alone operation—from 16 MB to 1 GB (2686A only)
- Multiple power sources: 100 V to 240 V and 9 V to 45 V dc
- Includes Fluke DAQ Software: Controls all 2680 Series functions, provides real-time and historical and also communicates with NetDAQ and Hydra Series III products

Fluke DAQ 6.0 Application Software

A powerful and versatile application for quick and easy configuration, data logging and analysis using Fluke data acquisition products.

- Easy multi-unit configuration for any mix of Fluke 2638A, 1586A, NetDAQ or 2680 Series
- Full screen trend charting of up to 32 channels with zoom, print and scaling functions
- Built-in OPC server software for sharing Fluke DAQ data with popular client programs
- Logon security features
- Auto start on power interrupt settings
- Master/slave configurations available
- Alarm logging with history with acknowledgement features
- Four web clients for remote viewing and control of systems using secure login
- Automated email of alarm alerts
- Up to 2000-channel capability
- Runs on a variety of operating systems including Windows 7 and 8



8845A/8846A



8808A



271



290



280

General purpose test equipment

8845A/8846A Precision Multimeters

Precision and versatility for bench or systems applications.

- 6.5 digit resolution
- Basic V dc accuracy of up to 0.0024 %
- Dual display, showing two different measurements at once

8808A Digital Multimeter

Versatile multimeter for manufacturing, development and service applications.

- 5.5 digit resolution
- Basic V dc accuracy of 0.015 %
- Dual display, showing two different measurements at once
- Ultra low-burden current measurement mode

271 DDS Function Generator with ARB

High performance function generator.

- High stability 10 MHz DDS function generator
- Arbitrary capability with storage for five user-defined waveforms
- Multiple standard and complex waveforms recalled from internal memory
- Extensive modulation capabilities include sweep, AM, Gating, Trigger/Burst, FSK and Hop
- GPIB and RS-232 interfaces

290 Series Waveform Generators

One, two, or four-channel 100 MS/s waveform generators.

- 100 MS/s 12-bit arbitrary waveform capability
- 1 M point waveform memory
- 40 MHz function generator capabilities using DDS (50 MHz for square waves)
- 10 ns pulse pattern generator
- Waveform sequencing with up to 1,024 segments
- Unlimited waveform storage using CF® memory card
- Waveform Manager Plus for Windows software
- USB interface in addition to RS-232 and GPIB

280 Series Waveform Generators

Universal waveform generators offering superior performance and value.

- Choice of 1, 2 and 4 independent or linked channels
- 40 MS/s max. sampling speed
- 16 MHz function generator
- 10 MHz pulse generator
- Pulse train pattern generator
- Arbitrary waveforms of up to 65 k points
- Powerful modulation capabilities
- Built-in trigger generators
- Waveform Manager Plus for Windows® software
- Multiple standard waveforms recalled from internal memory
- RS-232 and GPIB interfaces



Service programs



Priority Gold Instrument CarePlan

An instrument CarePlan from Fluke Calibration that guarantees your calibrator is ready to work when you are.

When your calibrator is out of your lab for scheduled calibration or unexpected repair, it isn't working for you. What's worse, you may not know exactly when to expect it back in your lab. With the Fluke Calibration Priority Gold CarePlan, you can schedule your calibrations and reduce repair downtime effectively, because you will know exactly when to expect your calibrator back in your lab. Your Priority Gold CarePlan puts you in control of your downtime and in control of your business.

Priority Gold CarePlan features:

- Annual calibration included with guaranteed in-house turnaround of three or six business days
- Free repairs with guaranteed in-house repair time of ten business days (includes calibration)
- Prepaid, priority freight on return of instrument
- Free product updates for the product covered by the Priority Gold CarePlan
- Term: one, three, and five-year plans available
- 10 % off Priority Gold CarePlans with the purchase of a new Fluke Calibration instrument
- 10 % off on product upgrades for the product covered by the Priority Gold CarePlan
- 15 % off any out-of-plan service charges for the product covered by the Priority Gold CarePlan
- 20 % off any Fluke Calibration scheduled metrology training for any of your personnel

Silver CarePlan

- Extended warranty for your Fluke Calibration instrument
- Repairs are always unexpected, and they can be costly. Control your cost of ownership with a Fluke Calibration Silver CarePlan. The Fluke Calibration Silver CarePlan is a comprehensive instrument warranty support plan that puts you in charge of your operating costs and protects your investment in your new Fluke Calibration instrument.

Silver CarePlan basic features:

- Extended warranty coverage for your instrument
- Calibration included on repairs covered by your plan
- 15 % discount on regular calibrations during your factory and Silver CarePlan term
- 15 % discount on any out-of-plan services
- Free product updates (PCNs) performed at the time of repair