

# Firepower®

## WELDING



## PLASMA



## OXYFUEL



## ACCESSORIES



*Cutting & Welding Products*

## Firepower® Products

### ***Performance, Value and Ease of Use***

Firepower, a leader in metal cutting, gas control and specialty welding solutions, is meeting the needs of people who demand professional-quality results, through a refined portfolio of Firepower branded products. These products represent the leading edge in design, performance, quality and safety, backed by 100 years of proven innovation.

The Firepower lineup offers superior performance, excellent value and ease-of-use that helps the craftsman to get the job done right the first time.

Firepower OxyFuel, incorporating the authentic Victor® torch and regulator range, is the heart of the Firepower family, with system solutions and components designed for individual needs. The OxyFuel range will perform a wide spectrum of tasks, from brazing sheet metal to cutting up to six-inch thick steel.

Firepower Plasma offers a broad range of Manual Plasma Cutters capable of slicing up to 1-1/2 inches in multiple metals. These machines are easy to use and can cut a variety of metals, including steel, aluminum, galvanized and more.

Firepower MST, with its new line up, comprises the core of the Firepower Welding range. Its technology has changed the game, setting a new standard for portable welding equipment. The 3-in-1 power supplies provide MIG, Stick and TIG capabilities in one integrated system. Firepower Velocity™ consumables allow for easy tip changes (no tip threads, no tools) while delivering longer life. Our consumables are designed for total welding flexibility and optimized welding performance with each process.

Firepower draws from the heritage and quality of Victor and Tweco equipment, with the added advantage of utilizing our excellence in product support, service and application know-how.



### **Select a Firepower Welding or Cutting Machine**

Using your Computer or Smartphone, try our new Firepower Selection Tool, which is an easy to use web device, that takes your selections and discovers what Firepower Machine could work best for you.

Part No. Index.....	2-3
<b>Section 1 – Welding Equipment</b>	
Welding Power Supply Selection Guide.....	4-5
MST 140i & MST 180i 3-in-1.....	6
MST 220i 3-in-1.....	7
3-in-1 Selection Comparison.....	8
MIG Guns.....	9, 15
MIG/Flux Cored Welders.....	10-11
MIG Spool Gun & FP-100.....	12
MIG Consumable Charts.....	13
MIG Consumables.....	14-15
TIG & Stick Welders.....	16-17
TIG Torches.....	18
TIG Consumable Charts.....	19
TIG Consumables.....	20-21
Welding Accessories.....	22-25
<b>Section 2 – Oxy-Fuel Equipment</b>	
Oxy-Fuel Solutions.....	26-27
Oxy-Fuel Outfits.....	28-29
Oxy-Fuel Regulators.....	30-31
Attachments, Handles & Torch.....	32
Accessories.....	33
Cutting Tips.....	34
Nozzles & Gauges.....	35
Adapters, Tanks & Flowmeter.....	36
Safety Eye/Face Protection.....	37
AirFuel Torches.....	38-39
<b>Section 3 – Plasma Equipment</b>	
Plasma Cutting Selection Guide.....	40-41
Plasma Cutting Machines.....	42-45
Plasma Welding/Cutting Carts.....	46
Plasma Consumables, Parts & Accessories.....	47
<b>Section 4 – Filler Metal</b>	
Stick Consumable Charts.....	48-49
Stick Electrode Reference Information.....	50-51
Electrodes.....	52-56
Welding Rods.....	57
Solder.....	58
Welding Wire.....	59
<b>Section 5 – Accessories</b>	
Safety.....	60-63
Tools.....	64-68
Brushes & Abrasives.....	69-80
<b>Gondola Merchandiser Plan-O-Gram.....</b>	<b>81</b>



PART NO.	PAGE	PART NO.	PAGE	PART NO.	PAGE	PART NO.	PAGE	PART NO.	PAGE	PART NO.	PAGE
1-1110-1	43	0323-0363	35	0781-9829	30	1423-1114	58	1423-2165	79	1423-3182	75
1-1130-1	45	0323-0364	35	0781-9830	30	1423-1209	65	1423-2166	79	1423-3184	75
1-4200	43	0323-0365	35	0781-9832	30	1423-1400	69	1423-2171	79	1423-3185	75
1-4200-7	43	0324-0112	35	0916-0028	33	1423-1402	69	1423-2172	79	1423-3186	88
1-5130-1	44	0324-0143	35	0916-0032	33	1423-1404	62	1423-2173	79	1423-3188	75
2-1020	42	0324-0146	35	0916-0033	33	1423-1405	79	1423-2178	89	1423-3189	75
7-8910	42	0324-0150	35	0916-0122	36	1423-1408	66	1423-2180	89	1423-3191	75
9-0091	47	0324-0151	35	1027-1390	12	1423-1419	81	1423-2185	73	1423-3193	75
9-0093	47	0324-0152	35	1027-1391	12	1423-1423	76	1423-2186	88	1423-3199	88
9-0094	47	0324-0153	35	1027-1392	12	1423-1425	68	1423-2187	88	1423-3201	88
9-0096	47	0324-0154	35	1412-0012	33	1423-1426	68	1423-2188	88	1423-3203	88
9-0097	47	0324-0155	35	1412-0020	33	1423-1428	76	1423-2189	88	1423-3208	75
9-0098	47	0381-0751	32	1412-0021	33	1423-1432	80	1423-2190	88	1423-3211	75
9-1260	42	0381-0759	32	1412-0022	33	1423-1435	67	1423-2191	88	1423-4100	61
9-6003	42	0381-0760	32	1412-0128	33	1423-1442	69	1423-2192	88	1423-4107	63
9-6006	42	0382-0358	32	1412-0134	33	1423-2100	70	1423-2197	89	1423-4133	62
9-6007	42	0384-0977	29	1420-0296	67	1423-2101	70	1423-2198	89	1423-4173	37
9-6099	42	0384-0978	29	1421-0062	68	1423-2102	70	1423-2202	73	1423-4175	37
9-8205	47	0384-1260	38	1421-0085	33	1423-2103	70	1423-2213	89	1423-4175	37
9-8206	47	0384-1280	38	1421-0098	23	1423-2104	70	1423-2220	78	1423-4181	37
9-8207	47	0384-2571	28	1421-0099	23	1423-2105	70	1423-2221	78	1423-4182	37
9-8208	47	0384-2572	28	1423-0016	66	1423-2106	71	1423-2224	73	1424-0013	35
9-8209	47	0384-2573	29	1423-0017	37	1423-2107	71	1423-2226	73	1424-0014	35
9-8210	47	0384-2682	28	1423-0018	37	1423-2108	71	1423-2232	88	1424-0015	35
9-8211	47	0384-2684	28	1423-0019	37	1423-2109	71	1423-2305	89	1424-0017	35
9-8212	47	0386-1226	33	1423-0020	37	1423-2110	71	1423-2310	77	1424-0019	35
9-8213	47	0387-0400	38	1423-0026	76	1423-2111	72	1423-2311	77	1424-0147	35
9-8215	47	0387-0436	36	1423-0032	76	1423-2113	72	1423-2312	77	1424-0148	35
9-8218	47	0387-0463	39	1423-0050	76	1423-2115	71	1423-2327	72	1424-0149	35
9-8225	47	0387-0464	39	1423-0051	62	1423-2116	71	1423-3142	75	1424-0150	35
9-8226	47	0387-0465	39	1423-0052	76	1423-2117	70	1423-3143	75	1424-0290	35
9-8227	47	0387-0470	38	1423-0081	69	1423-2118	70	1423-3144	75	1424-0292	35
9-8228	47	0387-0471	38	1423-0082	69	1423-2120	72	1423-3145	75	1424-0293	35
9-8231	47	0387-0487	66	1423-0083	69	1423-2121	72	1423-3146	75	1424-0294	35
9-8235	47	0387-0488	36	1423-0084	69	1423-2122	72	1423-3147	75	1424-0405	35
9-8236	47	0387-0489	36	1423-0086	64	1423-2123	72	1423-3148	75	1424-0406	35
9-8237	47	0387-0490	36	1423-0087	69	1423-2124	72	1423-3149	75	1424-0407	35
9-8241	47	0387-0491	36	1423-0093	69	1423-2125	72	1423-3150	75	1424-0408	35
9-8243	47	0387-0492	36	1423-0094	78	1423-2140	80	1423-3151	88	1424-0409	35
9-8251	47	0656-0000	33	1423-0095	78	1423-2141	80	1423-3152	88	1440-0080	56
9-8252	47	0656-0008	33	1423-0096	78	1423-2143	80	1423-3153	88	1440-0081	56
9-8253	47	0656-0016	33	1423-0097	78	1423-2151	80	1423-3155	75	1440-0083	55
9-8254	47	0781-2733	36	1423-1101	58	1423-2152	80	1423-3157	75	1440-0093	52
9-8258	47	0781-4238	31	1423-1102	58	1423-2154	80	1423-3158	71	1440-0095	52
0323-0270	35	0781-4239	31	1423-1108	58	1423-2155	80	1423-3159	71	1440-0096	52
0323-0271	35	0781-9726	31	1423-1109	58	1423-2157	80	1423-3162	78	1440-0097	52
0323-0272	35	0781-9727	31	1423-1110	58	1423-2158	80	1423-3163	78	1440-0098	52
0323-0360	35	0781-9826	31	1423-1111	58	1423-2160	80	1423-3164	78	1440-0105	52
0323-0361	35	0781-9827	30	1423-1112	58	1423-2161	80	1423-3177	73	1440-0106	52
0323-0362	35	0781-9828	31	1423-1113	58	1423-2164	79	1423-3181	89	1440-0107	52



# Part No. Index

PART NO.	PAGE	PART NO.	PAGE	PART NO.	PAGE	PART NO.	PAGE	PART NO.	PAGE	PART NO.	PAGE
1440-0108	52	1440-0220	59	1441-0004	61	1443-0490	24	1444-0890	14	6700-2596	34
1440-0115	52	1440-0221	59	1441-0015	37	1443-0491	25	1444-0891	14	6700-2618	34
1440-0116	52	1440-0222	59	1441-0023	61	1443-0494	24	1444-0892	14	6700-2619	34
1440-0117	52	1440-0230	59	1441-0038	61	1443-0495	25	1444-0893	14	6700-2620	34
1440-0118	52	1440-0231	59	1441-0042	61	1444-0025	14	1444-0894	12	6700-2621	34
1440-0124	52	1440-0235	59	1441-0047	63	1444-0026	14	1444-0900	22, 46	6700-2622	34
1440-0125	52	1440-0236	59	1441-0048	63	1444-0027	14	1444-0901	22, 46	6700-2623	34
1440-0126	52	1440-0240	59	1441-0049	63	1444-0029	14	1444-0902	23	6700-2624	34
1440-0127	52	1440-0241	59	1441-0050	63	1444-0050	14	6700-2408	34	20891010	65
1440-0134	52	1440-0245	59	1441-0085	54	1444-0051	14	6700-2409	34	20891013	65
1440-0135	52	1440-0296	58	1441-0086	54	1444-0052	14	6700-2410	34	20891017	65
1440-0136	52	1440-0374	55	1441-0087	54	1444-0075	15	6700-2411	34	20891018	65
1440-0137	52	1440-0400	53	1441-0088	54	1444-0080	15	6700-2412	34	20891020	65
1440-0145	52	1440-0401	53	1441-3408	37	1444-0082	15	6700-2413	34	20891023	65
1440-0146	52	1440-0402	53	1442-0002	21	1444-0140	14	6700-2414	34	20891024	65
1440-0147	52	1440-0404	53	1442-0003	20	1444-0141	14	6700-2415	34	20891025	65
1440-0148	52	1440-0405	53	1442-0004	20	1444-0142	14	6700-2416	34	20891026	65
1440-0150	52	1440-0406	53	1442-0005	20	1444-0165	15	6700-2438	34	W1003202	44
1440-0151	52	1440-0409	53	1442-0006	20	1444-0220	14	6700-2439	34	W1003203	44
1440-0152	52	1440-0411	53	1442-0007	20	1444-0221	14	6700-2440	34	W1003209	44
1440-0153	52	1440-0412	54	1442-0008	20	1444-0222	14	6700-2441	34	W1003210	44
1440-0155	54	1440-0413	54	1442-0009	20	1444-0224	14	6700-2442	34	W1003203	44
1440-0156	54	1440-0419	56	1442-0010	20	1444-0261	15	6700-2443	34	W1003209	44
1440-0165	45	1440-0420	56	1442-0011	20	1444-0265	15	6700-2444	34	W1003210	44
1440-0180	52	1440-0423	53, 55	1442-0020	18	1444-0322	10	6700-2445	34	W1003210	44
1440-0181	52	1440-0424	53, 55	1442-0021	18	1444-0324	10	6700-2468	34		
1440-0182	52	1440-0425	53, 55	1442-0022	18	1444-0326	11	6700-2469	34		
1440-0183	52	1440-0426	56	1442-0025	24	1444-0328	11	6700-2470	34		
1440-0185	52	1440-0427	57	1442-0030	17	1444-0346	11	6700-2471	34		
1440-0186	52	1440-0428	57	1442-0032	17	1444-0348	11	6700-2472	34		
1440-0187	52	1440-0429	58	1442-0036	16	1444-0406	15	6700-2473	34		
1440-0188	52	1440-0430	58	1442-0050	18	1444-0407	22, 46	6700-2474	34		
1440-0195	52	1440-0431	58	1442-0053	18	1444-0413	15	6700-2475	34		
1440-0196	52	1440-0433	57	1442-0054	20	1444-0417	15	6700-2476	34		
1440-0197	52	1440-0434	57	1442-0055	20	1444-0489	15	6700-2498	34		
1440-0198	52	1440-0440	53, 55	1442-0057	20	1444-0741	15	6700-2499	34		
1440-0200	52	1440-0441	53	1442-0059	21	1444-0870	6	6700-2500	34		
1440-0201	52	1440-0442	57	1442-0060	21	1444-0871	6	6700-2501	34		
1440-0202	52	1440-0443	55	1442-0061	21	1444-0872	7	6700-2502	34		
1440-0203	52	1440-0445	59	1442-0062	21	1444-0876	14	6700-2503	34		
1440-0205	52	1440-0447	59	1442-0065	21	1444-0877	14	6700-2504	34		
1440-0206	52	1440-0449	55	1442-0066	21	1444-0878	14	6700-2505	34		
1440-0207	52	1440-0456	59	1443-0003	72	1444-0879	14	6700-2588	34		
1440-0208	52	1440-0473	52	1443-0004	72	1444-0881	9	6700-2589	34		
1440-0210	59	1440-0474	52	1443-0005	72	1444-0882	9	6700-2590	34		
1440-0211	59	1440-0475	52	1443-0015	24	1444-0885	14	6700-2591	34		
1440-0212	59	1440-0476	52	1443-0016	24	1444-0886	14	6700-2592	34		
1440-0215	59	1440-0489	61	1443-0026	72	1444-0887	14	6700-2593	34		
1440-0216	59	1440-0496	54	1443-0027	72	1444-0888	14	6700-2594	34		
1440-0217	59	1440-0497	54	1443-0412	12	1444-0889	14	6700-2595	34		

WELDING



MIG

### Firepower® Welding Products

#### *Performance, Value and Ease of Use*

The latest Firepower Welding range offers superior performance, excellent value and ease-of-use that helps the craftsman get the job done right the first time.

Firepower draws on the heritage and quality of Tweco® equipment, and has the advantage of utilizing that excellence in product support, service, and application know-how.

This product range will perform a wide spectrum of welding tasks from thin gauge car panels to thick Industrial sections. Professionals from auto repair, construction, farm/ranch, skilled trades and serious do-it-yourselfers will find the superior solutions they need with Firepower.

The Firepower MST is the heart of the new line and has changed the game, setting a new standard for portable welding equipment. The 3-in-1 power supplies provide MIG, Stick, and TIG capability from one integrated portable system. They have been designed to provide users with total welding flexibility and optimized welding performance with each process. Firepower systems come complete with optimized accessories. These welding systems are ready to meet your needs right out of the box.



STICK



TIG

\* Please see page 40 for a quick explanation of duty cycle.

Product Name	MAX. Thickness	Weld Process	Input Power	Output Range	Gas Usage	Weldable Metals					
<b>STICK (SMAW)</b>											
@RATED DUTY CYCLE INPUT											
FP-100 1443-0412	THICKNESS 1/4" PLATE (6.4 mm) MULTI PASS ↑	STICK	INPUT PLUG 15 AMP 115 VAC	GENERATOR 2500 WATTS	MAX. OUTPUT 85 AMPS CURRENT AC DUTY CYCLE 15% @65 AMPS	GASLESS MATERIALS STEEL					
<b>ACDC TIG (GTAW) + STICK (SMAW)</b>											
TIG 140 ACDC 1442-0030	MAX. THICKNESS 3/16" PLATE (4.8 mm) SINGLE PASS ↑	TIG HF START LIFT TIG	STICK	INPUT PLUG 15 AMP 115 VAC	INPUT PLUG 20 AMP 115 VAC	GENERATOR 2800 WATTS	MAX. OUTPUT 140 AMPS	CURRENT AC DC	DUTY CYCLE 20% @140 AMPS 15.6 VOLTS	GAS FLEXIBLE GASES INERT ARGON	MATERIALS STEEL STAINLESS STEEL ALUMINUM
TIG 200 ACDC 1442-0032	MAX. THICKNESS 1/4" PLATE (6.4 mm) MULTI PASS ↑	TIG HF START LIFT TIG	STICK	INPUT PLUG 50 AMP 208/230 VAC	GENERATOR 9500 WATTS	MAX. OUTPUT 200 AMPS	CURRENT AC DC	DUTY CYCLE 20% @200 AMPS 18 VOLTS	GAS FLEXIBLE GASES INERT ARGON	MATERIALS STEEL STAINLESS STEEL ALUMINUM	
<b>MIG (GMAW)</b>											
FP-95 1444-0322	MAX. THICKNESS 1/8" PLATE (3.2 mm) SINGLE PASS ↑	MIG FLUX CORED	INPUT PLUG 15 AMP 115 VAC	GENERATOR 3500 WATTS	MAX. OUTPUT 90 AMPS	CURRENT DC	DUTY CYCLE 17% @85 AMPS 18.25 VOLTS	GASLESS MATERIALS MILD STEEL			
FP-125 1444-0324	MAX. THICKNESS 3/16" PLATE (4.8 mm) SINGLE PASS ↑	MIG FLUX CORED	INPUT PLUG 15 AMP 115 VAC	GENERATOR 5000 WATTS	MAX. OUTPUT 125 AMPS	CURRENT DC	DUTY CYCLE 19% @90 AMPS 18.5 VOLTS	GAS/GASLESS FLEXIBLE GASES ARGON CO <sub>2</sub>	MATERIALS STEEL STAINLESS STEEL		
FP-135 1444-0326	MAX. THICKNESS 1/4" PLATE (6.4 mm) MULTI PASS ↑	MIG FLUX CORED	INPUT PLUG 15 AMP 115 VAC	GENERATOR 6000 WATTS	MAX. OUTPUT 135 AMPS	CURRENT DC	DUTY CYCLE 28% @117 AMPS 19.85 VOLTS	GAS/GASLESS FLEXIBLE GASES ARGON CO <sub>2</sub>	MATERIALS STEEL STAINLESS STEEL		
FP-165 1444-0328	MAX. THICKNESS 5/16" PLATE (7.9 mm) MULTI PASS ↑	MIG FLUX CORED	INPUT PLUG 50 AMP 208/230 VAC	GENERATOR 7000 WATTS	MAX. OUTPUT 165 AMPS	CURRENT DC	DUTY CYCLE 18% @140 AMPS 21 VOLTS	GAS/GASLESS FLEXIBLE GASES ARGON CO <sub>2</sub>	MATERIALS STEEL STAINLESS STEEL		
<b>MST POWER SUPPLIES: 3-IN-1</b>											
MST 140i 1444-0870	MAX. THICKNESS 1/8" PLATE (3.2 mm) SINGLE PASS ↑	MIG STICK TIG LIFT TIG	INPUT PLUG 15 AMP 115 VAC	INPUT PLUG 20 AMP 115 VAC	GENERATOR 3500 WATTS	MAX. OUTPUT 140 AMPS	CURRENT DC	DUTY CYCLE 20% @90 AMPS 18.5 VOLTS	GAS/GASLESS FLEXIBLE GASES ARGON CO <sub>2</sub>	MATERIALS STEEL STAINLESS STEEL	
MST 180i 1444-0871	MAX. THICKNESS 1/4" PLATE (6.4 mm) MULTI PASS ↑	MIG STICK TIG LIFT TIG	INPUT PLUG 50 AMP 208/230 VAC	GENERATOR 9000 WATTS	MAX. OUTPUT 180 AMPS	CURRENT DC	DUTY CYCLE 30% @145 AMPS 22.5 VOLTS	GAS/GASLESS FLEXIBLE GASES ARGON CO <sub>2</sub>	MATERIALS STEEL STAINLESS STEEL ALUMINUM		
MST 220i 1444-0872	(115V)	MAX. THICKNESS 3/16" PLATE (4.8 mm) SINGLE PASS ↑	MIG STICK TIG LIFT TIG	INPUT PLUG 15 AMP 115 VAC	GENERATOR 3700 WATTS	MAX. OUTPUT 140 AMPS	CURRENT DC	DUTY CYCLE 20% @140 AMPS 18.5 VOLTS	GAS/GASLESS FLEXIBLE GASES ARGON CO <sub>2</sub>	MATERIALS STEEL STAINLESS STEEL ALUMINUM	
	(230V)	MAX. THICKNESS 3/8" PLATE (12.7 mm) MULTI PASS ↑	MIG STICK TIG LIFT TIG	INPUT PLUG 50 AMP 208/230 VAC	GENERATOR 7500 WATTS	MAX. OUTPUT 210 AMPS	DUTY CYCLE 20% @210 AMPS 23.5 VOLTS	GAS/GASLESS FLEXIBLE GASES ARGON CO <sub>2</sub>	MATERIALS STEEL STAINLESS STEEL ALUMINUM		





### MST 140i Multi-Process Welding System

#### Specifications

Part No.	Description
1444-0870	MST 140i, Multi-Process Welding System



<b>MIG</b> Icon of MIG gun	<b>STICK</b> Icon of Stick electrode	<b>TIG</b> Icon of TIG torch LIFT TIG	<b>GASLESS</b> Icon of gasless bottles	<b>MAX. OUTPUT</b> 140 AMPS	<b>MAX. THICKNESS</b> 1/8" PLATE (3.2 mm) SINGLE PASS ↑
<b>INPUT PLUG</b> 15 AMP 115 VAC	<b>INPUT PLUG</b> 20 AMP 115 VAC	<b>OUTPUT</b> DC	<b>FLEXIBLE GASES</b> ARGON CO <sub>2</sub>	<b>WARRANTY</b> 3 YEAR	<b>GENERATOR</b> 3500 WATTS

#### INCLUDES

Firepower MST 140i Power Supply, Firepower 140 Amp MIG Gun, Firepower Flow Meter Regulator / Gauge & Hose, Electrode Holder & Ground Clamp, 2 Drive Rolls and Contact Tips, 15-20 Amps Power Adapter, Shoulder Strap, and CD with Multi-Language Operating Instructions

#### APPLICATIONS

Farms/Ranches, Auto Applications, On-Site Repair - Does not work with Spool Gun

#### MACHINE SPECIFICATIONS

<b>Maximum Output</b>	140 Amp
<b>MIG (GMAW/FCAW)</b>	140A / 19V @ 15% Duty Cycle
<b>Welding Output @104°F (40°C)</b>	90A / 18.5V @ 20% Duty Cycle
<b>STICK (SMAW)</b>	90A / 23V @ 15% Duty Cycle
<b>Welding Output @104°F (40°C)</b>	80A / 23.2V @ 35% Duty Cycle
<b>TIG (GTAW)</b>	140A / 15.6V @ 15% Duty Cycle
<b>Welding Output @104°F (40°C)</b>	100A / 14V @ 20% Duty Cycle
<b>Current Range</b>	10 – 140 Amp
<b>MIG Welding Voltage Range</b>	14.5 – 19 Volt
<b>Wirefeed Speed Range</b>	90 – 390 IPM (2.3 – 9.9 m/min)
<b>Nominal OCV Volt/DC</b>	53 Volt
<b>Maximum Plate Thickness</b>	1/8" (3.2 mm)*

\* 30 Amp service required to obtain 3/16"

The Firepower MST 140i and MST 180i 3-in-1 machines come complete with all the necessary MIG & Stick components which gives even a beginner the capability to weld immediately, right out of the box. Both machines feature MIG, Stick, and TIG processes in a unit that weighs 33 pounds. The MST's both come with a Quick Start guide that walks you through the machine set-up in four simple steps. The MST 140i uses the 115 VAC, which allows you to weld virtually anywhere. The MST 180i comes with more power, using 208/230V and a maximum output of 180 Amps. The MST 180i is Spool Gun capable for Aluminum MIG welding. With the MST 140i and MST 180i you can be welding like a pro in no time.

### MST 180i Multi-Process Welding System

#### Specifications

Part No.	Description
1444-0871	MST 180i, Multi-Process Welding System

#### INCLUDES

Firepower MST 180i Power Supply, Firepower 180 MIG Gun, Firepower Flow Meter Regulator / Gauge & Hose, Electrode Holder & Ground Clamp, 2 Drive Rolls & Contact Tips, Standard 230V Plug, Shoulder Strap, and CD with Multi-Language Operating Instructions

#### APPLICATIONS

Farms/Ranches, Auto Applications, On-Site and Maintenance Repair

#### MACHINE SPECIFICATIONS

<b>Maximum Output</b>	180 Amp
<b>MIG (GMAW/FCAW)</b>	180A / 23V @ 20% Duty Cycle
<b>Welding Output @104°F (40°C)</b>	145A / 22.5V @ 30% Duty Cycle
<b>STICK (SMAW)</b>	175A / 27V @ 20% Duty Cycle
<b>Welding Output @104°F (40°C)</b>	140A / 25.6V @ 30% Duty Cycle
<b>TIG (GTAW)</b>	175A / 17V @ 25% Duty Cycle
<b>Welding Output @104°F (40°C)</b>	160A / 16.4V @ 30% Duty Cycle
<b>Current Range</b>	10 – 180 Amp
<b>MIG Welding Voltage Range</b>	14.5 – 26 Volt
<b>Wirefeed Speed Range</b>	100 – 650 IPM (2.5 – 16.5 m/min)
<b>Nominal OCV Volt/DC</b>	62 Volt
<b>Maximum Plate Thickness</b>	1/4" (6.4 mm)

<b>MIG</b> Icon of MIG gun	<b>STICK</b> Icon of Stick electrode	<b>TIG</b> Icon of TIG torch LIFT TIG	<b>GASLESS</b> Icon of gasless bottles	<b>MAX. OUTPUT</b> 180 AMPS	<b>MAX. THICKNESS</b> 1/4" PLATE (6.4 mm) SINGLE PASS ↑
<b>INPUT PLUG</b> 50 AMP 208/230 VAC	<b>OUTPUT</b> DC	<b>HERTZ</b> 50/60	<b>FLEXIBLE GASES</b> ARGON CO <sub>2</sub>	<b>WARRANTY</b> 3 YEAR	<b>GENERATOR</b> 9000 WATTS





## MST 220i Multi-Process Welding System

### Specifications

Part No.	Description
1444-0872	MST 220i, Multi-Process Welding System



The Firepower MST 220i has it all. It's the only machine in the 3-in-1 line that offers 115 and 208/230V, and provides MIG, Stick and TIG welding outputs for use anywhere. Portable enough to take to the job site, yet with 210 Amps maximum output, it has the power to meet your large job demands. This welding system is perfect for automotive repair and customization, mechanical contractors, farms/ranches, maintenance and repair, and garage and job shops. The MST 220i allows you to choose the best process for your applications. The MIG process provides maximum productivity in the shop, while the Stick process works ideally outdoors, and TIG is for those welding applications that require more precise control. The MST 220i is also Spool Gun capable for Aluminum MIG welding. There is no other machine like the MST 220i, it's a "must have" powerhouse!

### INCLUDES

Firepower MST 220i Power Supply, Firepower 220 Amp MIG Gun, Firepower Flow Meter Regulator / Gauge & Hose, Electrode Holder & Ground Clamp, 230V-115V Adapter Plug & Cable, 2 Drive Rolls & Contact Tips, Spring used for small 2 lb rolls, and CD with Multi-Language Operating Instructions

### APPLICATIONS

Farms/Ranches, Auto Applications, On-Site and Maintenance Repair

### MACHINE SPECIFICATIONS

Maximum Output	210 Amp
MIG (GMAW/FCAW)	110A / 19.5V @ 45% Duty Cycle (115V) 210A / 23.5V @ 20% Duty Cycle (230V)
Welding Output @104°F (40°C)	
STICK (SMAW)	110A / 24.8V @ 35% Duty Cycle (115V)
Welding Output @104°F (40°C)	200A / 25V @ 25% Duty Cycle (230V)
TIG (GTAW)	150A / 16V @ 35% Duty Cycle (115V)
Welding Output @104°F (40°C)	200A / 18V @ 25% Duty Cycle (230V)
Current Range	10 – 150 Amp (115V), 10 – 210 Amp (230V)
MIG Welding Voltage Range	14 – 30 Volt
Wirefeed Speed Range	100 – 600 IPM (2.5 – 15.2 m/min) @ 230V 100 – 400 IPM (2.5 – 10.2 m/min) @ 115V
Nominal OCV Volt/DC	62 Volt
Maximum Plate Thickness	3/8" (12.7 mm)



**Which MST is Best for You?**



WELDING DC	MST 140i	MST 180i	MST 220i
<b>Maximum Output</b>	<b>140 Amp</b>	<b>180 Amp</b>	<b>210 Amp</b>
<b>Order Information</b>	<b>Part No: 1444-0870</b> MST 140i System	<b>Part No: 1444-0871</b> MST 180i System	<b>Part No: 1444-0872</b> MST 220i System
<b>MIG (GMAW/FCAW)</b> Welding Output @104°F (40°C)	140A / 19V @ 15% Duty Cycle	180A / 23V @ 20% Duty Cycle	110A / 19.5V @ 45% Duty Cycle (115V)
	90A / 18.5V @ 20% Duty Cycle	145A / 22.5V @ 30% Duty Cycle	210A / 23.5V @ 20% Duty Cycle (230V)
<b>STICK (SMAW)</b> Welding Output @104°F (40°C)	90A / 23V @ 15% Duty Cycle	175A / 27V @ 20% Duty Cycle	110A / 24.8V @ 35% Duty Cycle (115V)
	80A / 23.2V @ 35% Duty Cycle	140A / 25.6V @ 30% Duty Cycle	200A / 25V @ 25% Duty Cycle (230V)
<b>TIG (GTAW)</b> Welding Output @104°F (40°C)	140A / 15.6V @ 15% Duty Cycle	175A / 17V @ 25% Duty Cycle	150A / 16V @ 35% Duty Cycle (115V)
	100A / 14V @ 20% Duty Cycle	160A / 16.4V @ 30% Duty Cycle	200A / 18V @ 25% Duty Cycle (230V)
<b>Current Range</b>	10 – 140 Amp	10 – 180 Amp	10 – 150 Amp (115V), 10 – 210 Amp (230V)
<b>MIG Welding Voltage Range</b>	14.5 – 19 Volt	14.5 – 26 Volt	14 – 30 Volt
<b>Wirefeed Speed Range</b>	90 – 390 IPM (2.3 – 9.9 m/min)	100 – 650 IPM (2.5 – 16.5 m/min)	100 – 600 IPM (2.5 – 15.2 m/min) @ 230V 100 – 400 IPM (2.5 – 10.2 m/min) @ 115V
<b>Nominal OCV Volt/DC</b>	53 Volt	62 Volt	62 Volt
<b>Maximum Plate Thickness</b>	1/8" (3.2 mm)	1/4" (6.4 mm)	3/8" (12.7 mm @ 230V), 3/16" (4.8 mm @ 115V)
<b>Wire Diameter Range</b>			
<b>Mild Steel:</b>	.023" – .030" (0.6 – 0.8 mm)	.023" – .030" (0.6 – 0.8 mm)	.023" – .030" (0.6 – 0.9 mm)
<b>Stainless Steel:</b>	.023" – .030" (0.6 – 0.8 mm)	.023" – .030" (0.6 – 0.8 mm)	.023" – .030" (0.6 – 0.9 mm)
<b>Aluminum:</b>	N/A	.030" – .035" (0.8 – 0.9 mm)*	.030" – 3/64" (0.8 – 1.2 mm)*
<b>Flux Cored:</b>	.030" – .035" (0.8 – 0.9 mm)	.030" – .035" (0.8 – 0.9 mm)	.030" – .045" (0.8 – 1.14 mm)
<b>Spool Size Capacity</b>	4" & 8" (100 & 200 mm)	4" & 8" (100 & 200 mm)	4", 8" & 12" (100, 200 & 300 mm)
<b>Power Source Dimensions (H x W x D)</b>	16.2" x 8.3" x 17.7" (410 mm x 210 mm x 450 mm)	16.2" x 8.3" x 17.7" (410 mm x 210 mm x 450 mm)	17.3" x 10.2" x 23.6" (440 mm x 260 mm x 600 mm)
<b>Power Source Weight</b>	32.2 lbs (14.6 kg)	32.2 lbs (14.6 kg)	57.3 lbs (26 kg)
<b>Warranty Period</b>	3 Years*	3 Years*	3 Years*
<b>Approvals</b>	IEC 60974-1, CSA E60974-1, UL 60974-1, ETL	IEC 60974-1, CSA E60974-1, UL 60974-1, ETL	IEC 60974-1, CSA E60974-1, UL 60974-1, ETL
<b>Protection Class</b>	IP23S	IP23S	IP23S
<b>PRIMARY POWER</b>			
<b>Primary Voltage</b>	115 VAC	208/230 VAC	115 VAC, 208/230 VAC
<b>Supply Voltage Range</b>	95 – 140 VAC	208 – 265 VAC	103 – 126 VAC, 208 – 265 VAC
<b>Number of Phases</b>	Single Phase	Single Phase	Single Phase
<b>Supply Frequency</b>	50/60 Hz	50/60 Hz	50/60 Hz
<b>Supply Plug</b>	NEMA 5-20P	NEMA 6-50P	NEMA 6-50P
<b>Rated kVA</b>	5 kVA @ 140 Amp	9 kVA @ 180 Amp	4.5 kVA (115V), 7 kVA (230V)
<b>Lead Cord Length</b>	10 ft (3 m)	10 ft (3 m)	10 ft (3 m)
<b>Maximum Input Current</b>	28.4 Amp	35.7 Amp	30.1 Amp (115V), 31.6 Amp (230V)
<b>OPTIONAL ACCESSORIES</b>			
Spool Gun - 1444-0894		✓	✓
Welding/Cutting Cart - 1444-0407	✓	✓	
Basic Utility Cart - 1444-0900	✓	✓	✓
Deluxe Welding/Cutting Cart - 1444-0901	✓	✓	✓
Roll Cage - 1444-0902			✓

### Firepower MIG Guns with Velocity™ Consumables

#### Specifications

Part No.	Description	For Use With
1444-0881	MIG Gun & Lead 180 Amps	MST 140i / MST 180i
1444-0882	MIG Gun & Lead 220 Amps	MST 220i

NOTE: MIG Guns include .023", .030" & .035" Contact Tips and 1/2" Nozzle Flush



- Ideal for light to medium gauge work in agriculture, architectural metal work, auto-body, DIY/hobbyist, HVAC, off-road vehicles, RV/campers, production welding, repair maintenance and general light fabrication.
- Operator appeal with ergonomic handle with diamond pattern for better grip and extended trigger length.
- Full range up to 220 Amps @ 40% Duty Cycle.
- Features new high performance Velocity™ Consumables.
- CE rated outputs and duty cycles.
- Rugged with steel spring strain relief.
- Built tough and designed to last.
- Best in class performance.



**FIREPOWER MIG 180**  
180 Amp @ 40% Duty Cycle

**FIREPOWER MIG 220**  
220 Amp @ 40% Duty Cycle

### Firepower Velocity™ MIG Welding Consumables

- Easy to change Velocity tips – no threads, no tools required.
- No diffuser – lower cost of ownership.
- Fewer consumable parts to replace – less complexity.
- Optimized wire feedability with centered liner.
- Solid copper conductive path with fewer connections – smooth, stable arc.
- Smooth, superior arc performance with less spatter, less clean-up.

#### STANDARD VELOCITY NOZZLE



Heavy Duty Copper

#### VELOCITY CONTACT TIP

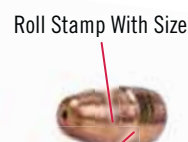

Large Copper to Copper Surface Contact for Superior Thermal and Electrical Efficiency

#### CONDUCTOR TUBE

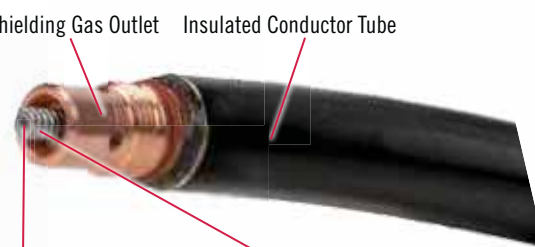

Perfectly Centered Liner

Roll Stamp With Size Shielding Gas Outlet Insulated Conductor Tube

Conduit Liner Seats Inside the Tip for Superior Feedability



Velocity Slip Fit Assembly



Velocity Flux Cored Assembly (Gasless)



### FP-95 Flux Cored Welding System

#### Specifications

Part No.	Description
1444-0322	FP-95, Flux-Cored Welding System



MIG FLUX CORED	MAX. OUTPUT <b>90</b> AMPS	INPUT PLUG <b>15</b> AMP 115 VAC	GASLESS FLUX CORED	DUTY CYCLE <b>17%</b> @85 AMPS 18.25 VOLTS	MAX. THICKNESS <b>1/8"</b> (3.2 mm) SINGLE PASS ↑
MATERIALS <b>MILD</b> STEEL	WIRE SIZE <b>UP TO</b> .035" (0.9 mm)	SAFETY <b>CSA</b> C <b>US</b>	WELD CURRENT <b>DC</b>	WARRANTY <b>5</b> YEAR	GENERATOR <b>3500</b> WATTS

#### FEATURES

- Portable FP-95 MIG/Flux-Cored Wire Welder
- Simple operation and easy to use key set up chart
- Operates from standard household outlet and delivers 90 Amps

#### INCLUDES

Tweco® Gun, return cable & clamp, 4 ft (1.2 m) power cord and NEMA 5-15P 115V plug, .035" spool of flux-cored wire and an operating manual. Gas Solenoid not included.

#### APPLICATIONS

Home DIY Hobbyist, Farm/Ranch, Maintenance & Repairs.

#### MACHINE SPECIFICATIONS

Maximum output	90 Amp
Duty cycle @ 104°F	15% @ 80 Amp at 17.5V
Current range	20-90 Amp
Number of voltage settings	2
Maximum plate thickness	1/8" (3.2 mm)
Wire diameter range	.030" - .035" (0.8 - 0.9 mm)
Dimensions (H x W x D)	11" x 7.75" x 14.5" (340 mm x 195 mm x 370 mm)
Weight	45 lbs (20.6 kg)
Maximum Input Current	28A
Approvals	CSA, ETL

### FP-125 MIG/Flux Cored Welding System

#### Specifications

Part No.	Description
1444-0324	FP-125, MIG/Flux-Cored Welding System



MIG FLUX CORED	MIG	MAX. OUTPUT <b>125</b> AMPS	INPUT PLUG <b>15</b> AMP 115 VAC	DUTY CYCLE <b>19%</b> @90 AMPS 18.5 VOLTS	MAX. THICKNESS <b>3/16"</b> (4.8 mm) SINGLE PASS ↑
MATERIALS <b>STEEL</b> STAINLESS STEEL	WIRE SIZE <b>UP TO</b> .035" (0.9 mm)	FLEXIBLE GASES <b>ARGON</b> <b>CO2</b>	SAFETY <b>CSA</b> C <b>US</b>	GAS/GASLESS	GENERATOR <b>5000</b> WATTS

#### FEATURES

- FP-125 MIG/Flux-Cored Welder offers maximum versatility. Wire Welder
- Offers quick-change internal polarity adjustment from MIG to Flux-Cored an easy switch
- Operates from standard 115V household outlet and delivers 125 Amps

#### INCLUDES

Tweco Gun, return cable & clamp, 6 ft (1.8 m) power cord and NEMA 5-15P 115V plug, .035" spool of flux-cored wire and an operating manual. Regulator must be purchased for MIG operation.

#### APPLICATIONS

Maintenance & Repairs, Farm/Ranch, Home DIY Hobbyist.

#### MACHINE SPECIFICATIONS

Maximum output	110 Amp
Duty cycle @ 104°F	20% @ 88 Amp at 18V
Current range	20-125 Amp
Number of voltage settings	4
Maximum plate thickness	3/16" (4.8 mm)
Wire diameter range	.023" - .035" (0.6 - 0.9 mm)
Dimensions (H x W x D)	12.75" x 9.75" x 17.35" (375 mm x 250 mm x 440 mm)
Weight	51 lbs (23.5 kg)
Maximum Input Current	38A
Approvals	CSA, ETL

### FP-135 MIG/Flux Cored Welding System

#### Specifications

Part No.	Description
1444-0326	FP-135, MIG/Flux-Cored Welding System
1444-0346	FP-135, Welding Kit



#### FP-135, Welding Kit (1444-0346)

##### PACKAGE INCLUDES:

- FP135 MIG Welder
- MIG Welder Cart
- Wire Brush
- Auto-Darkening Helmet
- Chipping Hammer
- Regulator

<b>MIG</b> FLUX CORED	<b>MIG</b> FLUX CORED	<b>MAX. OUTPUT</b> <b>135</b> AMPS	<b>INPUT PLUG</b> <b>15</b> AMP 115 VAC	<b>DUTY CYCLE</b> <b>28%</b> @117 AMPS 19.85 VOLTS	<b>MAX. THICKNESS</b> <b>1/4"</b> PLATE (6.4 mm) SINGLE PASS ↑
<b>MATERIALS</b> STEEL STAINLESS STEEL	<b>WIRE SIZE</b> <b>UP TO</b> <b>.035"</b> (0.9 mm)	<b>FLEXIBLE GASES</b> <b>ARGON</b> <b>CO<sub>2</sub></b>	<b>SAFETY</b> CSA US	<b>GAS/GASLESS</b>	<b>GENERATOR</b> <b>6000</b> WATTS

#### FEATURES

- FP-135 MIG/Flux-Cored Welder delivers a versatile and effective welding performance.
- Simple operation and easy to use key set up chart
- Operates from standard 115V household outlet and delivers 135 Amps

#### INCLUDES

Tweco Gun, return cable & clamp, 6 ft (1.8 m) power cord and NEMA 5-15P 115V plug, .030" spool of flux-cored wire and an operating manual.

#### APPLICATIONS

Home DIY Hobbyist, Farm/Ranch, Maintenance & Repairs, General light duty fabrication & repair.

#### MACHINE SPECIFICATIONS

Maximum output	135 Amp
Duty cycle @ 104°F	40% @ 90 Amp at 18V
Current range	20-135 Amp
Number of voltage settings	4
Maximum plate thickness	3/16" (4.8 mm)
Wire diameter range	.023" - .035" (0.6 - 0.9 mm)
Dimensions (H x W x D)	12.75" x 9.75" x 17.35" (375 mm x 250 mm x 440 mm)
Weight	56 lbs (25.5 kg)
Maximum Input Current	50A
Approvals	CSA, ETL

### FP-165 MIG/Flux Cored Welding System

#### Specifications

Part No.	Description
1444-0328	FP-165, MIG/Flux-Cored Welding System
1444-0348	FP-165, Welding Kit



#### FP-165 Welding Kit (1444-0348)

##### PACKAGE INCLUDES:

- FP165 MIG Welder
- MIG Welder Cart
- Wire Brush
- Auto-Darkening Helmet
- Chipping Hammer
- Regulator

<b>MIG</b> FLUX CORED	<b>MIG</b> FLUX CORED	<b>MAX. OUTPUT</b> <b>165</b> AMPS	<b>INPUT PLUG</b> <b>50</b> AMP 208/230 VAC	<b>DUTY CYCLE</b> <b>18%</b> @140 AMPS 21 VOLTS	<b>MAX. THICKNESS</b> <b>5/16"</b> PLATE (7.9 mm) SINGLE PASS ↑
<b>MATERIALS</b> STEEL STAINLESS STEEL	<b>WIRE SIZE</b> <b>UP TO</b> <b>.035"</b> (0.9 mm)	<b>FLEXIBLE GASES</b> <b>ARGON</b> <b>CO<sub>2</sub></b>	<b>SAFETY</b> CSA US	<b>GAS/GASLESS</b>	<b>GENERATOR</b> <b>7000</b> WATTS

#### FEATURES

- FP-165 MIG/Flux-Cored Welder delivers a very versatile and effective welding performance
- Simple operation and easy to use key set up chart
- Operates from standard 230V outlet and delivers 165 Amps

#### INCLUDES

Tweco Gun, return cable & clamp, 6 ft (1.8 m) power cord and NEMA 6-50P 230V plug, .030" spool of flux-cored wire and an operating manual.

#### APPLICATIONS

Maintenance & Repairs, Farm/Ranch, Home DIY Hobbyist, General light duty fabrication & repair.

#### MACHINE SPECIFICATIONS

Maximum output	165 Amp
Duty cycle @ 104°F	20% @ 130 Amp at 30V
Current range	20-165 Amp
Number of voltage settings	4
Maximum plate thickness	1/4" (6.4 mm)
Wire diameter range	.023" - .035" (0.6 - 0.9 mm)
Dimensions (H x W x D)	12.75" x 9.75" x 17.35" (375 mm x 250 mm x 440 mm)
Weight	60 lbs (27.3 kg)
Maximum Input Current	35A
Approvals	CSA, ETL

### MIG Spool Gun 160A Euro

#### Specifications

Part No.	Description	For Use With
1444-0894	MIG Spool Gun 160 Amps	MST 180i & MST 220i



Euro-Kwik Connector



MIG

MAX OUTPUT  
**160**  
AMPS

MATERIALS  
**ALUMINUM**

FLEXIBLE GASES  
**INERT ARGON**

#### FEATURES

- Interfaces with Firepower MST 180i and 220i 3-in-1 Welders
- Rated 20% Duty Cycle at 160 Amps
- Uses 11-Series Tips and Nozzles

#### APPLICATIONS

The MIG Spool Gun allows the use of Aluminum in welding applications.

#### CONTENTS

Firepower Spool Gun 160A, Custom Carrying Case, 12 ft (4 m) Cable with Euro-Kwik Connector, Conductor Tube, 2 - 0.023" (0.6 mm) 11-Series Contact Tips, 4 - 0.035" (0.9 mm) 11-Series Contact Tips, 2 - 1/2" (12.7 mm) 11-Series Nozzle, 2 - Gas Diffusers

\*Wire spool not included

### Tweco® Spool Guns

#### Specifications

Part No.	Description	For Use With
1027-1390	Tweco Spool Gun 160 Amp 20% Duty Cycle	Tweco Fabricators 141i, 181i, 211i
1027-1391	Tweco Spool Gun 200 Amp 60% Duty Cycle	Tweco Fabricator 252i
1027-1392	Tweco Spool Gun 200 Amp 60% Duty Cycle	Tweco Fabricators 210, 251, 281



Tweco Connector



#### FEATURES

- Excellent Service and Ease of Operation
- Comfortable Handle Design
- Quick Disconnect Conductor Tube
- Easy to Use
- Designed for Do-It-Yourself Applications

#### APPLICATIONS

These Tweco Spool Guns allow for the use of Aluminum in welding applications.

\*Wire spool not included

### FP-100 Stick/TIG Welding System

#### Specifications

Part No.	Description
1443-0412	FP-100 Stick/Arc Welding System



STICK

MAX. OUTPUT  
**85**  
AMPS

INPUT PLUG  
**15**  
AMP  
115 VAC

GASLESS

DUTY CYCLE  
**15%**  
@65 AMPS

MATERIAL  
**STEEL**

WELD CURRENT  
**AC**

WARRANTY  
**3 YEARS**  
ON TRANSFORMER

GENERATOR  
**2500**  
WATTS

#### FEATURES

- Infinite Amperage Control 5 to 85 Amps Output
- Ideal for Home, Farm and Light Maintenance Repairs
- Operates on Standard 115 Volt Household Power
- Power Cord and NEMA Plug 5-15P 115 VAC
- CSA & ETL Approved

#### APPLICATIONS

The FP-100 is ideal for home, farm and light maintenance repairs.



## MIG (GMAW) WELDING WIRE SELECTION

AWS Wire Class	Weld Material	Shield Gas Required	Wire Type	Polarity	Diameter
WIRE <b>MIG</b> ER 70S-6	Mild Steel	Yes	Solid Steel	DC Reverse (+)	.023 .030 .035 .045
WIRE <b>MIG</b> ER 308L	Stainless Steel	Yes	Solid Stainless	DC Reverse (+)	.030
WIRE <b>MIG</b> ER 4043	Aluminum	Yes	Solid Aluminum	DC Reverse (+)	.030 .035
WIRE <b>MIG</b> ER 5356					
WIRE <b>MIG</b> E71 T-GS *	Mild Steel	No	Flux Cored Gasless	DC Straight (-)	.030 .035

## MIG WIRE AMPERAGE RANGE

AWS Wire Class	Wire Diameter (in.)	Amperage Range							
		MIN.	50A	100A	150A	200A	250A	300A	MAX.
WIRE <b>MIG</b> ER 70S-6	SOLID WIRE .023			.025" - .050" †					
	MILD STEEL .030			.031" - 1/8" †					
	.035				.050" - 1/2" †				
	.045					.078" - 1/2" †			
WIRE <b>MIG</b> ER 308L	SOLID WIRE .030			.031" - 1/8" †					
	STAINLESS STEEL								
WIRE <b>MIG</b> ER 5356	SOLID WIRE .030			.031" - 1/8" †					
	ALUMINUM .035				.050" - 1/2" †				
WIRE <b>MIG</b> E71 T-GS *	FLUX CORED .030			.031" - .078" †					
	MILD STEEL .035				.037" - 3/16" †				

†Plate Thickness

†(Recommend multi pass over 3/16" plate thickness)

\*E71T-GS, Single Pass wire only.

## WELDING TIPS

- Keep the torch handle at a 45° angle with respect to the metal. Maintain the nozzle about 1/4" (0.6 mm) from the surface.
- Move the torch handle with prudence and steadiness.
- Avoid MIG welding in areas with too much draft. Too much draft blows away the shielding gas from the weld pool and may cause porosity in the weld.
- Keep the wire and its cover clean. DO NOT use rusted wire.
- Avoid sharp bends and kinks on the MIG gun cable.
- If possible, clean the wire liner with compressed air when replacing the wire spool.
- Periodically, remove the dust using low pressure air or nitrogen (2-3 Bar/30-45 psi) from the inside of the power source, to assure adequate heat dissipation from power source during operation.

### Tweco® MIG 11 & 14-Series Contact Tips

#### Specifications

Part No.	Description	Part No.	Description
1444-0025	MIG 11-Series .023" Contact Tip 10 PK	1444-0220	MIG 14-Series .023" Contact Tip 10 PK
1444-0026	MIG 11-Series .030" Contact Tip 10 PK	1444-0221	MIG 14-Series .030" Contact Tip 10 PK
1444-0027	MIG 11-Series .035" Contact Tip 10 PK	1444-0222	MIG 14-Series .035" Contact Tip 10 PK
1444-0029	MIG 11-Series .040" Contact Tip 10 PK	1444-0224	MIG 14-Series .045" Contact Tip 10 PK



#### FEATURES

- 10 Copper Tips Per Pack

#### APPLICATIONS

Used with 11 & 14-Series MIG Guns for MIG Welding.

### Tweco MIG 11 & 14-Series Nozzles

#### Specifications

Part No.	Description	Part No.	Description
1444-0050	MIG 11-Series 3/8" Flush Nozzle	1444-0140	MIG 14-Series 1/2" Flush Nozzle
1444-0051	MIG 11-Series 1/2" Flush Nozzle	1444-0141	MIG 14-Series 5/8" Flush Nozzle
1444-0052	MIG 11-Series 5/8" Flush Nozzle	1444-0142	MIG 14-Series 5/8" Flush Arc Nozzle



#### FEATURES

- Heavy Duty Copper Nozzle

#### APPLICATIONS

Used with 11 & 14-Series MIG Guns for MIG Welding.

### Tweco MIG Velocity™ Contact Tips

#### Specifications

Part No.	Description
1444-0890	MIG Velocity .023" Contact Tip 10 PK
1444-0891	MIG Velocity .030" Contact Tip 10 PK
1444-0892	MIG Velocity .035" Contact Tip 10 PK
1444-0893	MIG Velocity .045" Contact Tip 10 PK



#### FEATURES

- 10 Copper Tips Per Pack

#### APPLICATIONS

Used with Velocity® Series MIG Guns for MIG Welding.

### Tweco MIG Velocity Nozzles

#### Specifications

Part No.	Description	Part No.	Description
1444-0885	MIG Velocity 3/8" Flush Nozzle	1444-0888	MIG Velocity Flux Cored Nozzle
1444-0886	MIG Velocity 1/2" Flush Nozzle	1444-0889	MIG Velocity 3/4" Spot Nozzle
1444-0877	MIG Velocity 1/2" Recess Nozzle	1444-0876	MIG Velocity Adjustable Slip Fit Tip Holder
1444-0887	MIG Velocity 5/8" Flush Nozzle	1444-0879	MIG Velocity Adjustable Slip Fit Nozzle
1444-0878	MIG Velocity 5/8" Recess Nozzle		



#### FEATURES

- Heavy Duty Copper Nozzle

#### APPLICATIONS

Used with Velocity Series MIG Guns for MIG Welding.

### Firepower MIG Guns with Tweco® 11-Series Consumables

#### Specifications

Part No.	Description	For Use With	Part No.	Description	For Use With
1444-0413	MIG Gun 200 Amps (Requires 1444-0417 Adaptor when replacing a Tweco Style MIG Gun with a Helvi Gun)	FP-120, FP-130 & FP-160	1444-0741	MIG Gun, FP-120/130/160	FP-120, FP-130, FP-160
1444-0406	MIG Gun 300 Amps (Euro-Kwik Connector, Max Output Amps 230/270)	FP-200 & FP-260	1444-0417	Adaptor Tweco MIG Gun converted to Euro-Kwik	Tweco MIG Guns



### MIG Diffusers & Insulators

#### Specifications

Part No.	Description	Part No.	Description
1444-0080	MIG Diffuser – 51 for 180 Amp Gun 2 PK	1444-0265	MIG Diffuser – 54 for 400 Amp Gun 2 PK
1444-0082	MIG Diffuser – 35-50 Male Threads for Tweco Style Gun	1444-0489	MIG Diffuser – 35 Female Threads for Tweco Style Gun
1444-0165	MIG Diffuser – 52 for 250 Amp Gun 2 PK	1444-0075	MIG Insulator – For 250 Amp Gun 2 PK
		1444-0261	MIG Insulator – For 400 Amp Gun 2 PK



#### DIFFUSER FEATURES

- Strong Brass Construction

#### INSULATOR FEATURES

- Insulator Used by Slipping Over Nozzle

#### APPLICATIONS

Used with 11 & 14-Series MIG Guns for MIG Welding.





### TIG 140 ACDC Welding System

#### Specifications

Part No.	Description
1442-0030	TIG 140 ACDC Welding System



<b>TIG</b> HF START	<b>STICK</b>	<b>CURRENT</b> AC DC	<b>GAS</b>	<b>INPUT PLUG</b> 15 AMP 115 VAC	<b>MAX. THICKNESS</b> 3/16" PLATE (4.8 mm) SINGLE PASS
<b>TIG</b> 140 AMPS	<b>STICK</b> 90 AMPS	<b>MATERIALS</b> STEEL STAINLESS STEEL ALUMINUM	<b>FLEXIBLE GASES</b> INERT ARGON	<b>WARRANTY</b> 3 YEAR	<b>GENERATOR</b> 2800 WATTS

#### FEATURES

- HF TIG (GTAW), Lift TIG (GTAW), Stick (SMAW)
- 140 Amps of TIG Welding Output
- Smooth & Stable Arc Performance
- Includes 8-Pin Receptacle for On/Off & Amp Control at the TIG Torch
- Gas Solenoid Valve is Built-in
- Lightweight and Portable Inverter Design

#### INCLUDES

TIG 140 ACDC System, Ground Clamp & Electrode Holder, TIG Torch & Accessories, Flow Meter Regulator, 3 trigger Modules, Flow Gauge Hose 12.5 ft (3.8 m), 10 ft (3 m) Power Cord & NEMA 5-20P 115V AC Plug, Shoulder Strap and Operation Manual & CD

#### APPLICATIONS

**TIG WELDING (GTAW)** - The TIG 140 ACDC is capable of TIG welding on a wide range of materials from aluminum to mild and stainless steel. Delivering superior TIG welding performance with a smooth and stable arc down to 10 Amps.

**STICK WELDING (SMAW)** - The TIG 140 ACDC delivers up to 140 Amps of welding power and provides professional performances on a wide variety of materials. It's lightweight and portable with the ability to handle the toughest jobs.

#### MACHINE SPECIFICATIONS

Maximum output	140 Amp	
STICK (SMAW) Welding	90A @ 20%, 23.6V	
Output @104°F (40°C)	50A @ 60%, 22.0V; 40A @ 100%, 21.6V	
TIG (GTAW) Welding	140A @ 20%, 15.6V	
Output @104°F (40°C)	75A @ 60%, 13.0V; 60A @ 100%, 12.4V	
Current Range	Stick: 10 - 90A	TIG: 10 - 140A
Dimensions (H x W x D)	15.75"×9.45"×18.7" (400 mm×240 mm×475 mm)	
Weight	48.4 lbs (22 kg)	
Phase	1 PH	
Maximum Input Current	20 Amp	
Approvals	IP23S, EN 60974-1, CSA, ETL	

### TIG 200 ACDC Welding System

#### Specifications

Part No.	Description
1442-0032	TIG 200 ACDC Welding System



<b>TIG</b> HF START	<b>STICK</b>	<b>CURRENT</b> AC DC	<b>GAS</b>	<b>INPUT PLUG</b> 50 AMP 208/230 VAC	<b>MAX. THICKNESS</b> 1/4" PLATE (6.4 mm) SINGLE PASS ↑
<b>TIG</b> 200 AMPS	<b>STICK</b> 170 AMPS	<b>MATERIALS</b> STEEL STAINLESS STEEL ALUMINUM	<b>FLEXIBLE GASES</b> INERT ARGON	<b>WARRANTY</b> 3 YEAR	<b>GENERATOR</b> 9500 WATTS

#### FEATURES

- HF TIG (GTAW), Lift TIG (GTAW), Stick (SMAW)
- 200 Amps of TIG Welding Output
- Smooth & Stable Arc Performance
- Includes 8-Pin Receptacle for On/Off & Amp Control at the TIG Torch
- Gas Solenoid Valve is Built-in
- Lightweight and Portable Inverter Design

#### INCLUDES

TIG 200 ACDC System, Ground Clamp & Electrode Holder, TIG Torch & Accessories, Flow Meter Regulator, 3 trigger Modules, Flow Gauge Hose 12.5 ft (3.8 m), 10 ft (3 m) Power Cord & NEMA 6-50P 230V AC Plug, Shoulder Strap and Operation Manual & CD

#### APPLICATIONS

**TIG WELDING (GTAW)** - The TIG 200 ACDC is capable of TIG welding up to 200 Amps and a wide range of materials from aluminum to mild and stainless steel. Welding up to 1/4" plate, this machine can deliver superior TIG welding performance with a smooth and stable arc down to 10 Amps.

**STICK WELDING (SMAW)** - The TIG 200 ACDC delivers up to 170 Amps of welding power and provides professional performances on a wide variety of materials. With the 208/230V output it has more power to handle the biggest jobs.

#### MACHINE SPECIFICATIONS

Maximum output	200 Amp	
STICK (SMAW) Welding	170A / 26.6V @ 16% Duty Cycle	
Output @104°F (40°C)	150A / 26V @ 25% Duty Cycle	
	150A / 26V @ 100% Duty Cycle	
TIG (GMAW) Welding	200A / 18V @ 20% Duty Cycle	
Output @104°F (40°C)	180A / 17.2V @ 25% Duty Cycle	
	150A / 16V @ 35% Duty Cycle	
Current Range	Stick: 5-170 Amps	TIG: 10-200 AC 5-200 DC
Dimensions (H x W x D)	15.75" x 9.45" x 18.7" (400 mm x 240 mm x 475 mm)	
Weight	48.4 lbs (22 kg)	
Phase	1 PH	
Maximum Input Current	35.6 Amp	
Approvals	IP23S, EN 60974-1, CSA, ETL	



### TIG Torch

#### Specifications

Part No.	Description	For Use With
1442-0053	TIG Torch 17V	95 S & TIG 160S



#### FEATURES

- 50 mm Dinse Connector (TIG 160S) with 25 mm Dinse Adapter (95S)
- Includes Valve Knob for Shielding Gas
- 12.5' (3.8 m) Lead Length
- Gas Hose attached to Torch

#### APPLICATIONS

Designed for use with Thermal Arc® 95 S & FP TIG 160S.

*Note: TIG accessories not included.*



### TIG Torch & Accessories

#### Specifications

Part No.	Description	For Use With
1442-0020	TIG Torch 17V (with 1442-0065 Accessories)	MST 140i & MST 180i
1442-0021	TIG Torch 26V (with 1442-0066 Accessories)	MST 220i



#### FEATURES

- 50 mm Dinse Connector (25 mm Dinse Adaptor on 1442-0020 for MST 140i)
- 12' (3.6 m) Lead Length
- Valve Knob for Shielding Gas
- On/Off Switch
- Includes Set of Accessories: 2 Collets, 2 Collet Bodies, 2 Cup Aluminas, 2 Tungsten Electrodes, and a Short and Long Back Cap

#### APPLICATIONS

Designed for use with MST 140i, MST 180i, MST 220i and Fabricator 141i, 181i & 211i.



### TIG Torch SWCUR

#### Specifications

Part No.	Description	For Use With
1442-0022	TIG Torch 17 SWCUR	TIG 140 ACDC, 141 ACDC
1442-0050	TIG Torch 26 SWCUR	TIG 200 ACDC, 186 ACDC



#### FEATURES

- 50 mm Dinse Connector
- 12.5' (3.8 m) Lead Length
- No Shielding Gas Valve on Torch (Gas is controlled by power supply)
- Foot Switch Control Not Needed, but can be used
- **TIG Torch 17:** On/Off switch with current control
- **TIG Torch 26:** On/Off switch with current control and 2 additional interchangeable Amp modules

#### APPLICATIONS

Designed for use with TIG 140 ACDC, TIG 200 ACDC, and Fabricator 252i.

*Note: TIG accessories not included.*



## ALUMINUM (NON FERROUS METALS) TIG (GTAW) WELDING PARAMETERS (AC OUTPUT)

Base Metal Thickness	Tungsten Type (recommended)	Tungsten Electrode Dia.	Filler Rod Dia. (if required)	AC Amps Aluminum	Argon Gas Flow Rate	Weld Joint Type
.040" (1.0 mm)	Ceriated	.040" (1.0 mm) 1442-0059	1/16" (1.6 mm)	30-45 40-60	10 CFM (5 LPM) 13 CFM (6 LPM)	Butt/Corner
.045" (1.2 mm)				35-50 45-70	13 CFM (6 LPM)	Lap/Fillet
1/16" (1.6 mm)	Ceriated	1/16" (1.6 mm) 1442-0060	1/16" (1.6 mm)	60-85	15 CFM (7 LPM)	Butt/Corner
1/8" (3.2 mm)				70-95		Lap/Fillet
1/8" (3.2 mm)	Ceriated	3/32" (2.4 mm) 1442-0061	3/32" (2.4 mm)	125-150	21 CFM (10 LPM)	Butt/Corner
						Lap/Fillet
3/16" (4.8 mm)	Ceriated	1/8" (3.2 mm) 1442-0062	1/8" (3.2 mm)	130-160	21 CFM (10 LPM)	Butt/Corner
				180-225		Lap/Fillet

(Requirements may vary slightly by power supply)

## STEEL & STAINLESS STEEL (FERROUS METALS) TIG (GTAW) WELDING PARAMETERS (DC OUTPUT)

Base Metal Thickness	Tungsten Type (recommended)	Tungsten Electrode Dia.	Filler Rod Diameter	DC Amps Mild Steel	DC Amps Stainless Steel	Argon Gas Flow Rate	Weld Joint Type
.040" (1.0 mm)	Ceriated	.040" (1.0 mm) 1442-0059	1/16" (1.6 mm)	35-45	20-30 30-45	10 CFM (5 LPM) 13 CFM (6 LPM)	Butt/Corner
.045" (1.2 mm)				40-50	25-35 35-50	13 CFM (6 LPM)	Lap/Fillet
1/16" (1.6 mm)	Ceriated	1/16" (1.6 mm) 1442-0060	1/16" (1.6 mm)	60-70 80-100	40-60 65-85	15 CFM (7 LPM)	Butt/Corner
1/8" (3.2 mm)			3/32" (2.4 mm)	70-90 90-115	50-70 90-110		Lap/Fillet
3/16" (4.8 mm)	Ceriated	3/32" (2.4 mm) 1442-0061	1/8" (3.2 mm)	115-135	100-125	21 CFM (10 LPM)	Butt/Corner
				140-165	125-150		Lap/Fillet
1/4" (6.4 mm)	Ceriated	1/8" (3.2 mm) 1442-0062	5/32" (4.0 mm)	160-175	135-160	21 CFM (10 LPM)	Butt/Corner
				170-200	160-180		Lap/Fillet

(Requirements may vary slightly by power supply)



### TIG Collets

#### Specifications

Part No.	Description
1442-0003	TIG Collet .040" 5 PK
1442-0004	TIG Collet 1/16" 5 PK
1442-0005	TIG Collet 3/32" 5 PK
1442-0054	TIG Collet 1/8" 5 PK



#### FEATURES

- Standard Grade Brass Collets

#### APPLICATIONS

Holds Tungsten electrode in place and creates electrical contact for current transfer in TIG Welding. Used with Collet Body.

### TIG Collet Bodies

#### Specifications

Part No.	Description
1442-0006	TIG Collet Body .040" 5 PK
1442-0007	TIG Collet Body 1/16" 5 PK
1442-0008	TIG Collet Body 3/32" 5 PK
1442-0055	TIG Collet Body 1/8" 5 PK



#### FEATURES

- Standard Grade Brass Collet Bodies

#### APPLICATIONS

Fits its' respective size Collet and Tungsten electrode. Used with Collet.

### TIG Cup Aluminas

#### Specifications

Part No.	Description
1442-0009	TIG Cup Alumina #4 10 PK
1442-0010	TIG Cup Alumina #5 10 PK
1442-0011	TIG Cup Alumina #6 10 PK
1442-0057	TIG Cup Alumina #7 10 PK



#### FEATURES

- Ceramic Quality Cup Aluminas

#### APPLICATIONS

Protects the Collet Body and directs gas flow when TIG Welding.

### Tungsten 2% Ceriated

#### Specifications

Part No.	Description	Output Amps
1442-0059	Tungsten 2% .040" X 7" Ceriated, 10 PK	20-70†
1442-0060	Tungsten 2% 1/16" X 7" Ceriated, 10 PK	40-115†
1442-0061	Tungsten 2% 3/32" X 7" Ceriated, 10 PK	100-150†
1442-0062	Tungsten 2% 1/8" X 7" Ceriated, 10 PK	130-225†



#### FEATURES

- Best for DC Welding with Low Amperage

#### APPLICATIONS

Used when TIG Welding. Can be used for AC or DC Welding.



### TIG Accessory Kits

#### Specifications

Part No.	Description	Output Amps
1442-0065	TIG Accessory Kit .040" & 1/16"	20-115†
1442-0066	TIG Accessory Kit 3/32" & 1/8"	100-225†



#### APPLICATIONS

The TIG Accessory Kit Comes with All Consumables Necessary for TIG Torch operation.

#### CONTENTS: 1442-0065 - .040" & 1/16"

- Collets .040" & 1/16"
- Collet Bodies .040" & 1/16"
- Cup Aluminas # 4 & 5
- Tungsten Ceriated .040" & 1/16"

#### CONTENTS: 1442-0066 - 3/32" & 1/8"

- Collets 3/32" & 1/8"
- Collet Bodies 3/32" & 1/8"
- Cup Aluminas # 6 & 7
- Tungsten Ceriated 3/32" & 1/8"



### TIG Short Back Cap

#### Specifications

Part No.	Description
1442-0002	TIG Short Back Cap 2 PK



#### FEATURES

- Short Back Cap for TIG Welding in Smaller More Restricted Areas.

#### APPLICATIONS

Used to tighten the Collet which keeps the Tungsten electrode from moving while welding.



†Output Amps required depends on material type and thickness being welded.  
SEE CHART ON PAGE 13

### Welding/Cutting Cart

#### Specifications

Part No.	Description
1444-0407	Welding/Cutting Cart



#### FEATURES

- Fits Many Firepower Welders/Cutters (not MST 220i)
- Accommodates up to 9" (229 mm) diameter Cylinder with Included Chain
- Holds Welders/Cutters on Top Tray
- Sturdy and Durable Construction

#### FOR USE WITH

- MST 140i & 180i, FP-95, 125, 135, 165  
Thermal Arc 95 S, TIG 160S, TIG 140 ACDC & 200 ACDC  
Cutmaster 42, AirCut 15C, Fabricator 141i & 181i

### Basic Utility Cart

#### Specifications

Part No.	Description
1444-0900	Basic Utility Cart

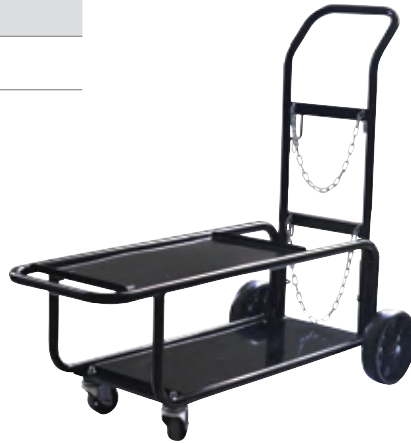

#### FEATURES

- Sturdy handle makes transporting welders/cutters easy
- Designed for most portable Welding/Cutting systems
- Rugged Solid Steel Construction
- Easy-rolling 8" (203 mm) diameter wheels
- 3" (76 mm) front-mounted casters
- Accommodates up to 9" (229 mm) diameter Cylinder with Included Chains

#### FOR USE WITH

- MST 140i, 180i, 220i, FP-95, 125, 135, 165  
Thermal Arc 95 S, TIG 160S, TIG 140 ACDC & 200 ACDC  
Cutmaster 42, 52, 82, CutSkill C-20A, C-35A, C-70A  
AirCut 15C, Fabricator 141i, 181i, & 211i, Fabricator 186 ACDC

### Deluxe Welding/Cutting Cart

#### Specifications

Part No.	Description
1444-0901	Deluxe Welding/Cutting Cart



#### FEATURES

- Single Cylinder Rack Accommodates up to 9" (229 mm) diameter Cylinder
- Large Accessory Drawer and Consumable Compartment
- Includes MIG/TIG Parts Storage Box
- Rugged Solid Steel Construction
- Designed for Most Firepower Welders/Cutters
- Includes Chain for Holding Tank

#### FOR USE WITH

- MST 140i, 180i, 220i, FP-95, 125, 135, 165  
Thermal Arc 95 S, TIG 160S, TIG 140 ACDC & 200 ACDC  
Cutmaster 42, 52, 82, CutSkill C-20A, C-35A, C-70A  
AirCut 15C, Fabricator 141i, 181i, & 211i, 252i, Fabricator 186 ACDC

### Roll Cage

#### Specifications

Part No.	Description	For Use With
1444-0902	Roll Cage (MST 220i Only)	MST 220i



#### FEATURES

- Rugged Steel Construction

#### APPLICATIONS

Roll Cage for MST 220i system, which protects and makes carrying the unit easier.

### Welder Carry Bag

#### Specifications

Part No.	Description	For Use With
1421-0099	Welder Carry Bag	MST 140i, MST 180i & MST 220i



#### FEATURES

- High Quality Made Bag
- Clear See-Through Documentation Pouch
- Reinforced Comfortable Handle
- Large Rugged Zipper

#### APPLICATIONS

Fits all Firepower MST 3-in-1 Systems.

### MIG/TIG Parts Storage Box

#### Specifications

Part No.	Description	For Use With
1421-0098	MIG/TIG Parts Storage Box	MIG/TIG Consumables



#### FEATURES

- Rugged Construction
- Easy-To-Use Snap Locking Closure System

#### APPLICATIONS

Customizable layout featuring removable storage dividers.



### Electrode Holder

#### Specifications

Part No.	Description	Use
1443-0015	Electrode Holder 200 Amps	Stick Welding
1443-0016	Electrode Holder 300 Amps	



#### FEATURES

- Reliable Tong Design
- Fiberglass Reinforced Insulators
- Copper Alloy Body
- Multi-Position Jaw Pattern
- Fully Insulated Spring

#### APPLICATIONS

The industry standard for your stick electrode welding applications with 200 or 300 Amp capacity.



### Electrode Holder & Lead

#### Specifications

Part No.	Description	For Use With
1443-0490	Electrode Holder & Lead 200 Amps	MST 140i & TIG 95S
1443-0494	Electrode Holder & Lead 200 Amps	MST 180i, MST 220i, TIG 160S, TIG 140 ACDC, TIG 200 ACDC



Electrode Holder 200 Amps	Electrode Holder 250 Amps
<b>FEATURES 1443-0490</b> <ul style="list-style-type: none"> <li>■ 25 mm Dinse Connector</li> <li>■ Reliable Tong Design</li> <li>■ Fully Insulated Spring</li> <li>■ Attached to a 9' (2.7 m) lead</li> <li>■ 200 Amp</li> </ul>	<b>FEATURES 1443-0494</b> <ul style="list-style-type: none"> <li>■ 50 mm Dinse Connector</li> <li>■ Reliable Tong Design</li> <li>■ Fully Insulated Spring</li> <li>■ Attached to a 9' (2.7 m) lead</li> <li>■ 250 Amp</li> </ul>
<b>APPLICATIONS</b> <p>The industry standard for your stick electrode welding applications</p>	



### TIG Foot Control

#### Specifications

Part No.	Description	For Use With
1442-0025	TIG Foot Control 15' 8-Pin	MST 140i, MST 180i, MST 220i, TIG 140 ACDC, TIG 200 ACDC, Fabricators 141i, 181i, 211i, 252i, & Thermal Arc 186 ACDC



#### FEATURES

- Comes with 15' Cable and 8-Pin Amphenol Plug

#### APPLICATIONS

Provides On/Off contactor and amperage control for your Firepower MST 140i, 180i, and 220i systems, and TIG 140 ACDC & TIG 200 ACDC.



### Premium Firepower Auto-Darkening Welding Helmets

#### Specifications

Part No.	Description
1441-0085	Firepower Pinstripes Auto-Darkening Welding Helmet
1441-0086	Firepower Piston & Plug Auto-Darkening Welding Helmet
1441-0087	Firepower Stars & Stripes Auto-Darkening Welding Helmet
1441-0088	Firepower Skull & Fire Auto-Darkening Welding Helmet



#### FEATURES

- Four Arc Sensors for High Response
- Automatically Turns from Light to Dark and Dark to Light
- Adjustable Welding Shade Levels from 9 to 13
- Light Shade DIN Level
- "Sensitivity" Control Range
- Selection for Process Mode
- Solar-Powered
- "Delay" Adjustable Controls



SMAW – 60 Amps or less PAW – 20 Amps or less PAC – 300 Amps or less	SHADE #9
SMAW – 60-160 Amps or less GMAW / FCAW – 60 Amps or less GTAW – 60 Amps or less PAW – 20-100 Amps or less	SHADE #10
GMAW / FCAW – 60-160 Amps or less	SHADE #11
SMAW – 160-250 GMAW / FCAW – 160-250 Amps or less GTAW – 50-150 Amps CAC-A – 500 Amps or less PAW – 100-400 Amps PAC – 300-400 Amps	SHADE #12
SMAW – 250-550 Amps GMAW / FCAW – 250-550 Amps GTAW – 150-500 Amps CAC-A – 500-1000 Amps PAW – 400-800 PAC – 400-800	SHADE #13

### Ground Clamp & Lead

#### Specifications

Part No.	Description	For Use With
1443-0491	Ground Clamp & Lead 200 A 25 mm Dinse	MST 140i & TIG 95S
1443-0495	Ground Clamp & Lead 200 A 50 mm Dinse	MST 180i, MST 220i, TIG 160S, TIG 140 ACDC, TIG 200 ACDC



#### Steel Ground Clamp

##### FEATURES 1443-0491

- Steel Levers
- Heavy Duty Spring
- Attached to a 6' (1.8 m) Lead
- 25 mm Dinse Connector

#### Copper Ground Clamp

##### FEATURES 1443-0495

- Rugged and Reliable Design
- Copper Cast Jaws
- Attached to a 10' (3 m) Lead
- 50 mm Dinse Connector

#### APPLICATIONS

The industry standard for your stick electrode welding applications with 200 Amp capacity

### Firepower® Oxy-Fuel

#### Performance, Value and Ease of Use

The latest Firepower Oxy-Fuel range offers superior performance, excellent value and ease-of-use that helps the craftsman get the job done right the first time. The authentic Victor® torch and regulator range is the heart of this new family, with system solutions and components designed for individual needs.

This product range will perform a wide spectrum of tasks, from brazing sheet metal to cutting up to six inch thick steel. Professionals from auto repair, construction, farm/ranch, skilled trades and serious do-it-yourselfers will find the superior solutions they need.

Firepower draws on the heritage and quality of Victor gas equipment, and has the advantage of utilizing that excellence in product support, service, and application know-how.

OXY-FUEL



**CUTTING**

#### ACETYLENE CUTTING TIPS



OxyFuel 350  
SERIES 1  
or  
OxyFuel 250  
SERIES 3

#### NATURAL GAS CUTTING TIPS



OxyFuel 350  
SERIES 1  
or  
OxyFuel 250  
SERIES 3

\*NOTE: For use with fuel gas other than Acetylene, proper tips, regulators or T-grade hoses may be required.



**HEATING**



#4 - 0323-0270

#6 - 0323-0271

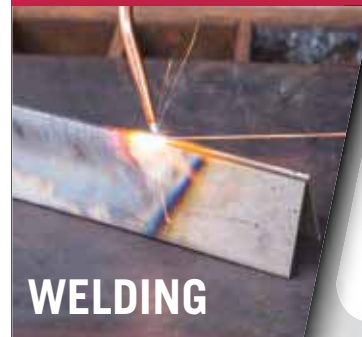

**WELDING**

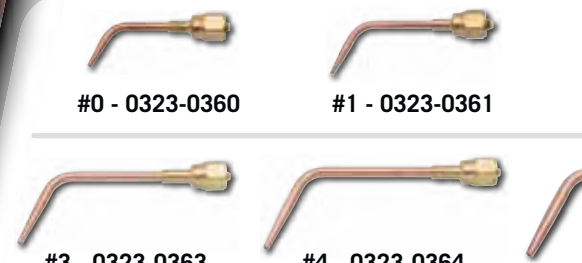

#0 - 0323-0360

#1 - 0323-0361

#3 - 0323-0363

#4 - 0323-0364

### Oxy-Fuel Regulators

#### OXYGEN

0781-9829  
350

0781-9826  
250



#### ACETYLENE

0781-9830  
350

0781-9827  
250





Full range of Cutting, Heating and Welding products for multiple gas types.

A flexible and versatile platform catered to applications from brazing thin sheet metal to cutting six inch thick steel we have the solution...

**PROPYLENE CUTTING TIPS**

OxyFuel 350 SERIES 1  
or  
OxyFuel 250 SERIES 3

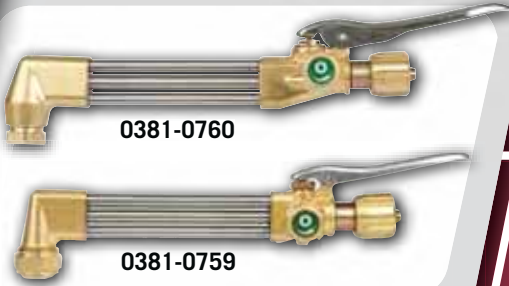

0381-0760

0381-0759



#8 - 0323-0272



Note:

1. "W" Nozzles Fits 7/8" Thread OxyFuel 250-350 Handles
2. "W-1" 5/8" Thread OxyFuel 150 Nozzles Also Available
3. Heating Nozzles Are Not Recommended For Use With Tote Outfits, and 0916-0032 and 0916-0033 Tanks.



#2 - 0323-0362

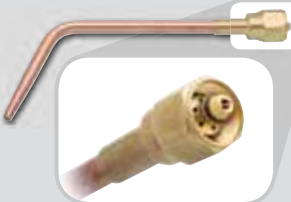

Note:

1. "W" Nozzles Fits 7/8" Thread OxyFuel 250-350 Handles
2. "W-1" 5/8" Thread OxyFuel 150 Nozzles Also Available

#5 - 0323-0365



0382-0358  
OXYFUEL 250/350 HANDLE

0656-0008  
FLASHBACK ARRESTORS

OXY-FUEL

**Oxy-Fuel Outfits**

**250 MEDIUM DUTY**



0384-2571 BOX  
0384-2572 CLAMSHELL

**350 HEAVY DUTY**



0384-2682 BOX  
0384-2684 CLAMSHELL



### OxyFuel 350 Heavy Duty Outfit

#### Specifications

Part No.	Description	Fuel Gas Type
0384-2682	OxyFuel 350 Heavy Duty Outfit (Box)	Acetylene
0384-2684	OxyFuel 350 Heavy Duty Outfit (Clamshell)	Acetylene



#### FEATURES

- High performance, complete system that meets or exceeds industry standards
- Superior 350 Series high flow color coded regulators
- Complete handle and cutting attachment optimized for multiple gases
- Up to 6" cutting capacity and 1/2" welding
- Flexible versatile platform
- Includes flashback arrestors
- Two year warranty

#### APPLICATIONS

The OxyFuel 350 Heavy Duty Outfit contains premium performance components for professional grade use. Optimized for 1" cut and 1/8" weld out of the box. Suitable for medium to heavy duty fusion welding, braze welding, brazing, heating and hand cutting applications.

#### CONTENTS

Oxygen/Acetylene 350 Series Regulators, 350 Series Cutting Attachment and Handle, Flashback Arrestors, Dual R-Grade Hose 3/16" x 12.5 ft., #1 Cutting Tip, #2 Welding Nozzle, Striker, Protective eyewear and Manual.



OXY-FUEL

### OxyFuel 250 Medium Duty Outfit

#### Specifications

Part No.	Description	Fuel Gas Type
0384-2571	OxyFuel 250 Medium Duty Outfit (Box)	Acetylene
0384-2572	OxyFuel 250 Medium Duty Outfit (Clamshell)	Acetylene



#### FEATURES

- High performance, complete system that meets or exceeds industry standards
- High performance 250 Series color coded regulators
- Complete handle and cutting attachment optimized for multiple gases
- Up to 5" cutting capacity and 1/2" welding
- Flexible versatile platform
- Two year warranty

#### APPLICATIONS

The OxyFuel 250 Medium Duty Outfit contains premium performance components for the value driven consumer. Optimized for 1/2" cut and 5/64" weld out of the box. Suitable for light to medium duty fusion welding, braze welding, brazing, heating and hand cutting applications.

#### CONTENTS

Oxygen/Acetylene 250 Series Regulators, 250 Series Cutting Attachment and Handle, Dual R-Grade Hose 3/16" x 12.5 ft., #0 Cutting Tip, #0 Welding Nozzle, Striker, Protective eyewear and Manual.



### OxyFuel 250 Tote

#### Specifications

Part No.	Description	Fuel Gas Type
0384-0977	OxyFuel 250 Outfit, complete with carry tote and empty tanks*	Acetylene
0384-0978	OxyFuel 250 Outfit, complete with carry tote, no tanks*	Acetylene



#### FEATURES

- Complete portable system
- Cutting torch and handle are ready for multiple gas options; Oxy-Acetylene, Propane, Butane, Natural & LP Gases, & Propylene
- Simple to use rear-mount regulator with high contrast gauges
- Meets or exceeds industry safety standards
- Cut 1/8" (3.2 mm) to 3" (76.2 mm) steel
- Weld up to 1/4" (6.4 mm) Steel
- Constructed with high strength alloys, heavy duty stainless steel and durable brass
- Two year warranty

NOTE: TANKS ARE FOR EXCHANGE ONLY AND ARE EMPTY

#### APPLICATIONS

This OxyFuel 250 outfit complete with carry tote and empty tanks is the ideal entry level starter package. Optimized for 1/2" cut and 1/8" weld out of the box. Suitable for light duty fusion welding, braze welding, brazing and hand cutting applications.\*

#### CONTENTS

Oxygen/Acetylene 150 Series Regulators, 250 Series Cutting Attachment and Handle, cylinder wrench with chain, Dual R-Grade Hose 3/16" x 12.5 ft., #0 Cutting Tip, #2 Welding Nozzle, Striker, Protective eyewear, Tote Carry Pak with storage and Manual. (with or without OX-20 cu. ft. Type "R" and AC-MC10 cu. ft. tanks depending on part no.)

\*Not Recommended For Use With Heating Nozzles Due To Tank Size.

OXY-FUEL

### OxyFuel 250 Replacement Torch Kit

#### Specifications

Part No.	Description	Fuel Gas Type
0384-2573	OxyFuel 250 Torch Replacement Kit	All



\*NOTE: For use with fuel gas other than Acetylene, proper tips, regulators or T-grade hoses may be required.

#### FEATURES

- Cutting torch and handle are ready for multiple gas options; Oxy-Acetylene, Propane, Butane, Natural & LP Gases, & Propylene
- Ergonomic color coded knobs (Acetylene & Oxygen)
- Meets or exceeds industry safety standards
- Cut 1/8" (3.2 mm) to 5" (127 mm) steel
- Heat using multiple heat nozzles
- Weld up to 1/2" (12.7 mm) steel
- Constructed with high strength alloys and heavy duty stainless steel and durable brass
- Two year warranty

#### APPLICATIONS

This OxyFuel 250 replacement torch kit delivers the latest generation of Victor® professional torch and handle design and operating platform.

#### CONTENTS

250 Series Cutting Attachment and Handle, #0 Cutting Tip, #0 Welding Nozzle, and Manual.

### Oxy-Fuel Acetylene Regulator

#### Specifications

Part No.	Description	Gas Type
0781-9827	OxyFuel 250 Acetylene Regulator, 510 CGA, 2-15 PSIG	Acetylene
0781-9830	OxyFuel 350 Acetylene Regulator, 510 CGA, 2-15 PSIG	Acetylene



#### FEATURES

- High performance single stage regulator with precise pressure and flow control
- Large clear gauges enable both inlet and delivery pressures to be read at a glance
- Clear color coding for the correct gas usage
- Forged brass body and high strength alloy bonnet
- Meets or exceeds industry standards
- 9/16" -18 outlet connection (LH)
- Two year warranty

#### APPLICATIONS

The OxyFuel 250 and 350 Acetylene regulators are suitable for a wide range of cutting, heating and welding applications using Acetylene fuel gas only.\*

### Oxy-Fuel Oxygen Regulator

#### Specifications

Part No.	Description	Gas Type
0781-9826	OxyFuel 250 Oxygen Regulator, 540 CGA, 10-150 PSIG	Oxygen
0781-9829	OxyFuel 350 Oxygen Regulator, 540 CGA, 10-150 PSIG	Oxygen



#### FEATURES

- High performance single stage regulator with precise pressure and flow control
- Large clear gauges enable both inlet and delivery pressures to be read at a glance
- Clear color coding for the correct gas usage
- Forged brass body and high strength alloy bonnet
- Meets or exceeds industry standards
- 9/16" -18 outlet connection (RH)
- Two year warranty

#### APPLICATIONS

The OxyFuel 250 and 350 Oxygen regulators are suitable for a wide range of cutting, heating and welding applications using Oxygen gas only.

### Argon/CO<sub>2</sub> Mixes Flowgauged Regulator

#### Specifications

Part No.	Description	Gas Type
0781-9832	Argon/CO <sub>2</sub> Flowgauged Regulator, 580 CGA, 10-150 PSIG	Argon/CO <sub>2</sub>



#### FEATURES

- High performance single stage regulator with precise pressure and flow control
- Large clear gauges enable both inlet and delivery pressures to be read at a glance
- Clear color coding for the correct gas usage
- Forged brass body and high strength alloy bonnet
- Meets or exceeds industry standards
- 9/16" -18 outlet connection (RH)
- Two year warranty

#### APPLICATIONS

The Argon/CO<sub>2</sub> Flowgauged Regulator is suitable for MIG and TIG welding applications using Argon and CO<sub>2</sub> gas mixtures.



### OxyFuel G150 Tote Regulators

#### Specifications

Part No.	Description	Gas Type
0781-4238	OxyFuel G150 Tote Acetylene Regulator, 200 CGA, 2-15 PSIG	Acetylene
0781-4239	OxyFuel G150 Tote Oxygen Regulator, 540 CGA, 4-60 PSIG	Oxygen



#### FEATURES

- High performance single stage regulator with precise pressure and flow control
- Large clear gauges enable both inlet and delivery pressures to be read at a glance
- Forged brass body and high strength alloy bonnet
- Meets or exceeds industry standards
- 9/16" -18 outlet connection (LH)
- Standard CGA, rear mount gas connections for Oxygen tote kits
- Two year warranty

#### APPLICATIONS

The OxyFuel G150 Tote Regulators are suitable for a wide range of cutting, heating, and welding applications.

OXY-FUEL

### High Pressure Regulators

#### Specifications

Part No.	Description	Gas Type
0781-9726	1500 High Pressure Regulator, 580 CGA, 100-1500 PSIG	Helium, Argon, Nitrogen
0781-9727	3000 High Pressure Regulator, 680 CGA, 200-3000 PSIG	Helium, Argon, Nitrogen



#### FEATURES

- 0-4000 PSI cylinder gauge
- Max Inlet 3000
- 2-1/2" diameter gauges
- Brass construction, single stage regulator
- Two year warranty

#### APPLICATIONS

Heavy Duty, high pressure piston regulator.

### Inert Regulator

#### Specifications

Part No.	Description	Gas Type
0781-9828	250 Inert Flow Regulator, 580 CGA, 5-200 PSIG	Inert



#### FEATURES

- High performance single stage regulator with precise pressure and flow control
- Large clear gauges enable both inlet and delivery pressures to be read at a glance
- Clear color coding for the correct gas usage
- Forged brass body and high strength alloy bonnet
- Meets or exceeds industry standards
- 9/16" -18 outlet connection (RH)
- Two year warranty

#### APPLICATIONS

The Inert Flowgauge Regulator is designed specifically for use with Nitrogen and Helium gases.



### Oxy-Fuel Cutting Attachments

#### Specifications

Part No.	Description	Fuel Gas Type
0381-0418	OxyFuel 150 Cutting Attachment, "W-1" Series, 5/8" Handle Thread	All
0381-0759	OxyFuel 250 Cutting Attachment, "W" Series, 7/8" Handle Thread	All
0381-0760	OxyFuel 350 Cutting Attachment, "W" Series, 7/8" Handle Thread	All

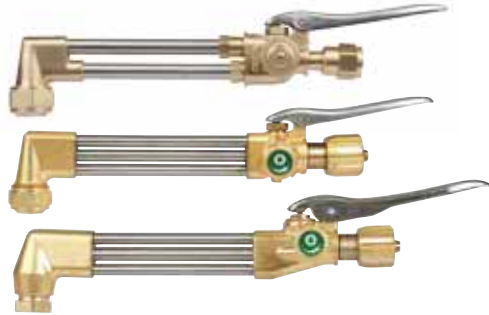

#### FEATURES

- Meets or exceeds Industry Standards
- Attaches quickly and easily to Oxy-Fuel handle (no tools required), 7/8" thread
- Cutting oxygen lever securely fitted to the body for ease of operation
- High strength triple stainless steel tube construction with good cutting visibility
- Multi gas operation: Oxy-Acetylene, Propane, Butane, Natural & LP Gases, & Propylene
- Cutting capacity up to 6" (350), up to 5" (250)
- Two year warranty

#### APPLICATIONS

Suitable for the following processes: hand cutting.

### Oxy-Fuel Cutting/Welding Handles

#### Specifications

Part No.	Description	Hose Connection	Fuel Gas Type
0382-0032	OxyFuel 150 Torch Handle, "W-1" Series, 5/8" Handle Thread	"B" 9/16"-18	All
0382-0358	OxyFuel 250-350 Torch Handle, "W" Series, 7/8" Handle Thread	"B" 9/16"-18	All



#### FEATURES

- Meets or exceeds Industry Standards
- High strength durable brass and alloy handle, "W" nozzle connection 7/8" thread
- High precision valves for sensitive control for delicate welding jobs
- Easy light up for high flow heating applications
- Multi gas operation: Oxy-Acetylene, Propane, Butane, Natural & LP Gases, & Propylene
- Left and right hand threads prevent incorrect hose connection, 1/4" thread
- Color coded control knobs for maximum safety and ease of use, even when wearing gloves
- Two year warranty

#### APPLICATIONS

The Oxy-Fuel Cutting and Welding Handle connects to Oxy-Fuel Cutting attachments and a complete line of Heating and Welding nozzles. Suitable for the following processes: Fusion welding, braze welding, brazing, soldering, heating, hand cutting.

NOTE: For use with Fuel Gas other than Acetylene. Proper Tips, Regulators or T-Grade Hoses may be required.

### Oxy-Fuel Straight Cutting Torch

#### Specifications

Part No.	Description	Hose Connection	Fuel Gas Type
0381-0751	350 OxyFuel ST900 Straight Cutting Torch	"B" 9/16"-18	All



#### FEATURES

- Cutting torch and handle are ready for multiple gas options; Oxy-Acetylene, Propane, Butane, Natural & LP Gases, & Propylene
- Labeled knobs (Acetylene & Oxygen)
- Meets or exceeds industry safety standards
- Cut 1/8" (3.2 mm) to 6" (152.4 mm) steel
- Constructed with high strength alloys, heavy duty stainless steel and durable brass
- Includes built-in patented flash back arrestors
- Two year warranty

#### APPLICATIONS

Suitable for the following processes: hand cutting.

### Oxy-Fuel Hoses

#### Specifications

Part No.	Description	Fitting	Fuel Gas Type
1412-0012	3/16" x 12.5 ft. Dual R-Grade	"A" 3/8"-24	Acetylene
1412-0020	3/16" x 25 ft. Dual R-Grade	"A" 3/8"-24	Acetylene
1412-0021	1/4" x 25 ft. Dual R-Grade	"B" 9/16"-18	Acetylene
1412-0022	1/4" x 50 ft. Dual R-Grade	"B" 9/16"-18	Acetylene
1412-0134	3/16" x 12.5 ft. Dual T-Grade	"A" 3/8"-24	All
1412-0128	1/4" x 25 ft. Dual T-Grade	"B" 9/16"-18	All



#### FEATURES

- Premium quality hose that meets or exceeds the requirements of RMA and CGA
- Secure, specifically designed hose fittings ensure operator safety
- Color coded for easy identification
- Precut to length with fitted connections
- 12.5 ft., 25 ft. and 50 ft. lengths in 3/16" and 1/4" thread connector
- R-Grade hose recommended for use with Acetylene

#### KEY INFORMATION

It is important to use the correct type of hose for the required gas(es) to be used. Any non-standard application should always be checked and approved before being put into operation. Pressure drops will occur through hoses and hose fittings, therefore allowances must be made to compensate for this when setting up equipment and adjusting regulators. Color coding of hoses and different threads for fuel and Oxygen prevents incorrect connections of hoses to the wrong gas type. Dual hoses help to keep the work area tidy, which reduces the risk of hose damage.



Oxy-Fuel hoses are Grade "R" recommended for Oxygen and Acetylene, available in pre fitted lengths from 12.5 ft. to 50 ft. Compatible with all the Oxy-Fuel range and suitable for light to heavy duty fusion welding, braze welding, brazing, heating and hand cutting applications.

### Oxy-Fuel Flashback Arrestors

#### Specifications

Part No.	Description	Fuel Gas Type
0656-0008	OxyFuel 250-350 FBT-2 Torch Flashback arrestors set with check valves	All
0656-0000	KC-1 Kwik Connect™ Pair Pak (Oxygen and Fuel)	All
0656-0016	OxyFuel 250-350 FPRA Regulator Flashback arrestor set with check valves	All



#### FEATURES

- Provide ultimate protection against "Flashback" and premature failure of system components
- High flow capacity
- Non-return valve
- Large cylindrical stainless steel flame arrestor

#### APPLICATIONS

Designed for connection to the inlet of the torch handle and used for all cutting, heating and welding applications.



### Oxy-Fuel Tanks & Totes

#### Specifications

Part No.	Description	Fuel Gas Type
0916-0033	<b>OX-20</b> Type "R" Oxygen Cylinder, 20 cu. ft. Capacity*	Oxygen
0916-0032	<b>AC-MC</b> Type "MC" Acetylene Cylinder, 10 cu. ft. Capacity* ISO/DOT/TC	Acetylene
1421-0085	Cylinder Tote Only	All
0916-0028	<b>NT-40</b> Nitrogen Cylinder, 40 cu. ft. (For Nitrogen Purging) ISO/DOT/TC	Nitrogen
0386-1226	TK Tank Key	-



#### FEATURES AC-MC\*

- Type "MC" Acetylene Cylinder, 10 cu. ft. Capacity
- CGA 200 Connection
- DOT, TC Certified

#### FEATURES NT-40

- 40 cu. ft. Nitrogen Cylinder
- CGA 580 Connection
- DOT, TC Certified

#### FEATURES OX-20\*

- Type "R" Oxygen Cylinder, 20 cu. ft. Capacity
- CGA 540 Connection
- DOT, TC Certified

#### APPLICATIONS

Tote and small tanks designed for smaller cutting and welding jobs allowing easy transport with this highly portable system.



\*Not Recommended To Use Heating Nozzles With The 0916-0033 and 0916-0032 Tanks.

### Oxy-Fuel Cutting Tips

Refer to Table Below



#### ACETYLENE

#### NATURAL GAS

#### PROPYLENE

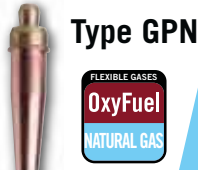

#### FEATURES

- Longer Nozzle life – high grade copper and advanced manufacturing techniques give the Firepower Oxy-Fuel superior cutting life.
- Better quality cutting – the mirror smooth finish of the gas ports assures stable gas flow and superior cutting oxygen stream. Cuts are clean and smooth with the narrowest kerf.
- Less slag adhesion – copper content conducts heat away from the nozzle face. The nozzle keeps cooler and slag adherence to the nozzle face is reduced.
- Consistent manufacture batch testing ensures Oxy-Fuel nozzles will consistently deliver the highest quality performance

#### APPLICATIONS

Used for cutting steel 1/8" to 6" thick.

\*NOTE: For use with fuel gas other than Acetylene, proper tips, regulators or T-grade hoses may be required.

OXY-FUEL



### - ACETYLENE TYPE CUTTING TIPS (TYPE 101)



TIP SIZE	PLATE THICKNESS	OXYFUEL 250 SERIES 3 - PART NO.	OXYFUEL 350 SERIES 1 - PART NO.	FUEL GAS FLOW (SCFH)	FUEL GAS PRESSURE (PSIG)	OXYGEN FLOW (TOTAL SCFH)	CUTTING OXYGEN PRESSURE (PSIG)
000	1/8" - 3 mm	6700-2438	6700-2408	3/5	3/5	20/25	20/25
00	1/4" - 6 mm	6700-2439	6700-2409	4/6	3/5	30/35	20/25
0	1/2" - 13 mm	6700-2440	6700-2410	6/10	3/5	60/65	30/35
1	3/4" - 19 mm	6700-2441	6700-2411	8/13	3/5	80/85	30/35
2	1" - 25 mm	6700-2442	6700-2412	10/16	3/6	140/150	35/40
3	2" - 51 mm	6700-2443	6700-2413	14/22	4/9	210/225	40/45
4	3" - 76 mm	6700-2444	6700-2414	18/30	5/10	270/320	40/50
5	5" - 127 mm	6700-2445	6700-2415	26/38	5/13	425/450	50/55
6	6" - 152 mm	-	6700-2416	30/44	7/13	500/600	45/40



### - NATURAL GAS TYPE CUTTING TIPS (TYPE GPN)



\*NOTE: To use these GPN tips, a T-grade hose and GPN regulators are required.

TIP SIZE	PLATE THICKNESS	OXYFUEL 250 SERIES 3 - PART NO.	OXYFUEL 350 SERIES 1 - PART NO.	FUEL GAS FLOW (SCFH)	FUEL GAS PRESSURE (PSIG)	OXYGEN FLOW (TOTAL SCFH)	CUTTING OXYGEN PRESSURE (PSIG)
000	1/8" - 3 mm	6700-2498	6700-2468	5/6	3/5	12/14	20/25
00	1/4" - 6 mm	6700-2499	6700-2469	5/7	3/5	22/26	20/25
0	1/2" - 13 mm	6700-2500	6700-2470	8/10	3/5	50/55	30/35
1	3/4" - 19 mm	6700-2501	6700-2471	10/12	4/6	70/80	30/35
2	1" - 25 mm	6700-2502	6700-2472	12/15	4/8	115/125	35/40
3	2" - 51 mm	6700-2503	6700-2473	14/18	5/9	150/175	40/45
4	3" - 76 mm	6700-2504	6700-2474	16/20	8/12	210/250	45/50
5	5" - 127 mm	6700-2505	6700-2475	20/30	8/12	330-360	50/55
6	6" - 152 mm	-	6700-2476	25/35	10/15	400/500	45/55



### - PROPYLENE GAS TYPE CUTTING TIPS (TYPE GPP)



\*NOTE: To use these GPP tips, a T-grade hose and GPP regulators are required.

TIP SIZE	PLATE THICKNESS	OXYFUEL 250 SERIES 3 - PART NO.	OXYFUEL 350 SERIES 1 - PART NO.	FUEL GAS FLOW (SCFH)	FUEL GAS PRESSURE (PSIG)	OXYGEN FLOW (TOTAL SCFH)	CUTTING OXYGEN PRESSURE (PSIG)
000	1/8" - 3 mm	6700-2618	6700-2588	5/6	3/5	12/14	20/25
00	1/4" - 6 mm	6700-2619	6700-2589	5/7	3/5	22/26	20/25
0	1/2" - 13 mm	6700-2620	6700-2590	8/10	3/5	50/55	30/35
1	3/4" - 19 mm	6700-2621	6700-2591	10/12	4/6	70/80	30/35
2	1" - 25 mm	6700-2622	6700-2592	12/15	4/8	115/125	35/40
3	2" - 51 mm	6700-2623	6700-2593	14/18	5/9	150/175	40/50
4	3" - 76 mm	6700-2624	6700-2594	16/20	8/12	210/250	45/50
5	5" - 127 mm	-	6700-2595	20/30	8/12	330/360	50/55
6	6" - 152 mm	-	6700-2596	25/35	10/15	400/500	45/55

### Oxy-Fuel Heating Nozzles

#### Specifications

Part No.	Description	Fuel Gas Type	Size	Oxygen Pressure (PSIG)	Acetylene Pressure (PSIG)	Oxygen Consumption (SCFH)	Acetylene Consumption (SCFH)
0323-0270	250-350 Series Multi-flame Nozzle (Clamshell)	Acetylene	4	8/12	6/10	7/22	6/20
0324-0143	150 Series Multi-flame Nozzle (Clamshell)	Acetylene	4	8/12	6/10	7/22	6/20
0323-0271	250-350 Series Multi-flame Nozzle (Clamshell)	Acetylene	6	10/15	8/12	15/44	14/40
0324-0146	150 Series Multi-flame Nozzle (Clamshell)	Acetylene	6	10/15	8/12	15/44	14/40
0323-0272	250-350 Series Multi-flame Nozzle (Clamshell)	Acetylene	8	20/30	10/15	33/88	30/80
0324-0112	150 Series Multi-flame Nozzle (Clamshell)	Acetylene	8	20/30	10/15	33/88	30/80



#### FEATURES

- Concentrated high temperature flame
- Wide range for different applications
- Connects directly to the Oxy-Fuel torch handle platform\*

#### APPLICATIONS

Used for concentrated heating of steel and other materials.

\*Heating Nozzles Are Not Recommended For Use With Tote Outfits, and 0916-0032 and 0916-0033 Tanks.



### Oxy-Fuel Welding Nozzles

#### Specifications

Part No.	Description	Fuel Gas Type	Metal Inches	Thickness Mm	Drill Size	Oxygen (PSIG)	Acetylene (PSIG)	Acetylene (SCFH)
0323-0360	#0 Acetylene Welding Nozzle	Acetylene	5/64"	1.9	65 (0.035)	3/5	3/5	2/4
0324-0150	#0 Acetylene 150 Welding Nozzle	Acetylene	5/64"	1.9	65 (0.035)	3/5	3/5	2/4
0323-0361	#1 Acetylene Welding Nozzle	Acetylene	3/32"	2.4	60 (0.040)	3/5	3/5	3/6
0324-0151	#1 Acetylene 150 Welding Nozzle	Acetylene	3/32"	2.4	60 (0.040)	3/5	3/5	3/6
0323-0362	#2 Acetylene Welding Nozzle	Acetylene	1/8"	3.2	56 (0.046)	3/5	3/5	5/10
0324-0152	#2 Acetylene 150 Welding Nozzle	Acetylene	1/8"	3.2	56 (0.046)	3/5	3/5	5/10
0323-0363	#3 Acetylene Welding Nozzle	Acetylene	1/16"	4.8	53 (0.060)	4/7	3/6	8/18
0324-0153	#3 Acetylene 150 Welding Nozzle	Acetylene	1/16"	4.8	53 (0.060)	4/7	3/6	8/18
0323-0364	#4 Acetylene Welding Nozzle	Acetylene	1/4"	6.4	49 (0.073)	5/10	4/7	10/25
0324-0154	#4 Acetylene 150 Welding Nozzle	Acetylene	1/4"	6.4	49 (0.073)	5/10	4/7	10/25
0323-0365	#5 Acetylene Welding Nozzle	Acetylene	1/2"	12.7	43 (0.089)	6/12	5/8	15/35
0324-0155	#5 Acetylene 150 Welding Nozzle	Acetylene	1/2"	12.7	43 (0.089)	6/12	5/8	15/35



#### FEATURES

- Concentrated high temperature flame
- Wide range for different applications
- Connects directly to the Oxy-Fuel torch handle platform

#### APPLICATIONS

Used for fusion welding, braze welding, brazing, and soldering of thin steel and other weldable materials.



### Replacement Gauges

#### Specifications

Part No.	G-150 Series 1.5" Gauges	Max PSI	Thread Size	Part No.	250 Series 2" Gauges	Max PSI	Thread Size	Part No.	350 Series 2.5" Gauges	Max PSI	Thread Size
1435-0090RP	Acetylene Only	15	1/8" NPT	1424-0013	Acetylene Only	30	1/4" NPT	1424-0290	Acetylene Only	30	1/4" NPT
1435-0091RP	All Gases	87	1/8" NPT	1424-0014	All Gases	60	1/4" NPT	1424-0292	All Gases	200	1/4" NPT
1435-0092RP	All Gases	580	1/8" NPT	1424-0015	All Gases	100	1/4" NPT	1424-0293	All Gases	400	1/4" NPT
1435-0093RP	All Gases	4568	1/8" NPT	1424-0017	All Gases	400	1/4" NPT	1424-0294	All Gases	4000	1/4" NPT
				1424-0019	All Gases	4000	1/4" NPT				





### Adapters

#### Specifications

Part No.	Description	Fuel Gas Type
0387-0490	FP Adapter CGA 300Tank/510Reg.	ALL
0387-0492	FP Adapter CGA 510Tank/300Reg.	ALL
0387-0488	FP Adapter CGA 510Tank/520Reg.	ALL
0387-0491	FP Adapter CGA 520Tank/200Reg.	ALL
0387-0489	FP Adapter CGA 520Tank/510Reg.	ALL



#### FEATURES

- Adapts different sized cylinders to the regulator
- Forged brass body

#### APPLICATIONS

0387-0490 - Allows the connection between a CGA 300 Tank to a 510 Regulator.  
 0387-0492 - Allows the connection between a CGA 510 Tank to a 300 Regulator.  
 0387-0488 - Allows the connection between a CGA 510 Tank to a 520 Regulator.  
 0387-0491 - Allows the connection between a CGA 520 Tank to a 200 Regulator.  
 0387-0489 - Allows the connection between a CGA 520 Tank to a 510 Regulator.



### AirFuel Tanks

#### Specifications

Part No.	Description	Fuel Gas Type
0387-0436	Firepower FP 1 lb. Propane Tank	Propane
0916-0122	MAP//Pro™, 600 CGA	MAP//Pro



#### FEATURES

- Contains 14.1 oz. propane

#### APPLICATIONS

Replacement tank for use with all Firepower hand torches.



### Welding Flowmeter Regulator

#### Specifications

Part No.	Description	Fuel Gas Type
0781-2733	Weld Gas Flowmeter, HRF 1480-580 FPH, 580 CGA	Argon/CO <sub>2</sub>



#### FEATURES

- Maximum inlet pressure 3,000 PSIG, outlet pressure is present for 80 PSIG
- Flow range is 10-50/Argon gas, 580 CGA male threaded connection
- Model includes 10" gas hose
- Easy to read flow tube for accurate adjustments
- Specifically designed for MIG, TIG and other inert gas welding applications
- Two year warranty

#### APPLICATIONS

The Flowmeter Regulator is used with most MIG or TIG welding applications.



### Welder's Goggles

#### Specifications

Part No.	Description		FEATURES	
1423-4181	Shade 5 Protective Eyewear		Rubber arm tips assure comfort and non-slip use, ultra-light frames allow comfortable protection and eliminates 99.9% Ultraviolet light. Hard-coated polycarbonate lens with tilting arms and a contoured frame.	  
1423-0017	Fixed Front, Welder's Goggle Soft Frame		Filter Lens Shade 5 with soft vinyl frame to fit over corrective glasses and adjustable elastic headband.	   
1423-0018	Lift Front, Welder's Goggle Soft Frame		Filter Lens Shade 5 raises easily for on-the-job versatility. Made soft vinyl frame to fit over corrective glasses and adjustable elastic headband.	  
1423-0019	Cup-Type Goggle, 50 mm		Hard Plastic with Shade 5 polycarbonate lens and adjustable elastic headband and nose piece.	   
1423-4175	Grinding Shield with Clear Visor, 8" x 12" x .040"		Ratchet quickly adjusts headband to various sizes.	 
1441-0015	Clear visor for face shield, 8" x 12" x .040"		High grade PETG for excellent protection against paints and mild chemicals. Wide flare for maximum protection and universal hole pattern fits most brand name headgear.	 

OXY-FUEL

### AirFuel Pencil Tip Torch & Kit

#### Specifications

Part No.	Description	Fuel Gas Type
0387-0470	Firepower P-10 Pencil Tip Propane Torch	Propane
0387-0471	Firepower FP PK-10 Pencil Tip Propane	Propane



#### FEATURES

- For use with 14.1 oz. or 16 oz.
- Solid Brass burn tube construction.
- Two year warranty

#### APPLICATIONS

The Manual Light Propane Pencil Tip Torch is suitable for Brazing, Heating and Soldering.

### AirFuel Hand Torch Kit

#### Specifications

Part No.	Description	Fuel Gas Type
0387-0400	Firepower AirFuel Manual Light Hand Torch	Propane, MAP//PRO™



#### FEATURES

- Silver solder copper tubing or Bronze braze steel pipe
- Swirl combustion tip maximizes heat and reduces brazing time by 30%
- For 14.1 oz. or 16 oz. disposable Propane or MAP//Pro
- Two year warranty

#### APPLICATIONS

The Manual Light Hand Torch is suitable for Brazing, Heating and Soldering.

### AirFuel Vers-A-Flame Torch Kits

#### Specifications

Part No.	Description	Fuel Gas Type
0384-1280	Firepower Vers-A-Flame 350K BTU 1 Ea	Propane
0384-1260	Firepower Vers-A-Flame 500K BTU 1 Ea	Propane



#### FEATURES

- Durable Brass Control Knob
- Tough 10' Hose
- Meets or exceeds Industry Safety Standards
- For use with LP Tanks 20 lbs. or Larger
- Two year warranty

#### APPLICATIONS

The Vers-A-Flame is suitable for a wide range of uses.  
 Auto/Farm & Home use: Burns weeds, removes paint and melts ice.  
 Construction uses: Preheat asphalt & tar, remove road markings and reheat large castings for welding.

### AirFuel Hand Torch

#### Specifications

Part No.	Description	Fuel Gas Type
0387-0463	Firepower AirFuel SMP-31 Hand Torch	Propane, MAP//Pro™

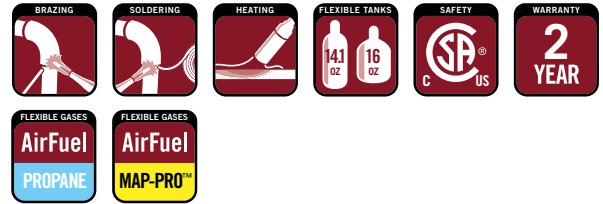

#### FEATURES

- Auto Igniter for Instant Flame
- Trigger lock on button
- For 14.1 oz. or 16 oz. disposable Propane or MAP//Pro
- Two year warranty

#### APPLICATIONS

The Auto Igniting Hand Torch is suitable for Brazing, Heating and Soldering.

### AirFuel Torch Kit

#### Specifications

Part No.	Description	Fuel Gas Type
0387-0464	Firepower AirFuel SMPK-31 Torch Kit	Propane, MAP//Pro

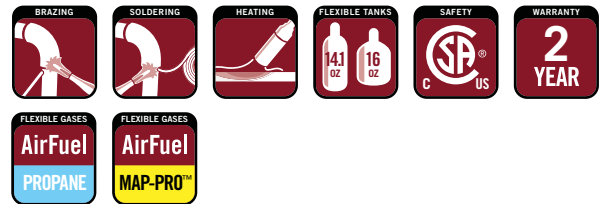

#### FEATURES

- Auto Igniter for Instant Flame
- Trigger lock on button
- For 14.1 oz. or 16 oz. disposable Propane or MAP//Pro
- Two year warranty

#### APPLICATIONS

The Auto Igniting Hand Torch is suitable for Brazing, Heating and Soldering.

### AirFuel Hand Torch

#### Specifications

Part No.	Description	Fuel Gas Type
0387-0465	Firepower AirFuel SMP-41 Hand Torch	Propane, MAP//Pro

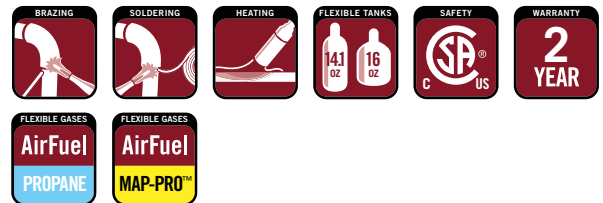

#### FEATURES

- Auto Igniter for Instant Flame
- Trigger lock on button
- For 14.1 oz. or 16 oz. disposable Propane or MAP//Pro
- Two year warranty

#### APPLICATIONS

The Auto Igniting Hand Torch is suitable for Brazing, Heating and Soldering.





**AIR CUT**

## Firepower® Plasma Products

### *Performance, Value and Ease of Use*

The Firepower Plasma range utilizes equipment from a proven leader in plasma cutting technology, Thermal Dynamics®.

Thermal Dynamics' innovative and performance proven manual plasma cutting systems are also easy to use. These plasma arc cutting systems can be used to cut virtually any material, from light gauge to 1-1/2" thick, and are highly portable units.



**CUTMASTER**

The Cutmaster® TRUE™ Series has been designed with the idea that recommended cut capacity should also be the TRUE cut capacity. The TRUE Cut Series eliminates the concept of having to “buy up”, purchasing a machine larger than you actually need. With the introduction of the Cutmaster TRUE Series, a one-half inch recommended capacity machine will cut one-half inch material ALL DAY, EVERY DAY. NO EXCEPTIONS.

### **Duty Cycle Information**

The duty rating defines how long the machine can be used before work must be stopped, in order to let the machine cool down. Duty cycle ratings are expressed as a percentage of a ten-minute period. It represents the maximum welding and cutting time allowed at the specified amperage setting. The remaining balance of the ten-minute period is required for cooling down the machine. For example, if the machine has a 40% duty cycle at 150 amps, it can weld up to 4 minutes and then needs to cool off for the remaining 6 minutes. If a machine is operated below its rated output, the duty cycle typically increases.



**PLASMA**

Product Name	Clean Cut Thickness	Max. Thickness	Input Power		Output Range			Material	Gas Usage			
<b>AirCut™ 15C</b> 1-1110-1	CC THICKNESS 1/8" (3 mm)	MAX THICKNESS 3/16" (5 mm) WITH OPTIONAL TIPS	INPUT POWER 15 AMP 115 VAC	GENERATOR 2000 WATTS	OUTPUT 15 AMPS	PHASE 1 PH	CURRENT DC	DUTY CYCLE 35% @15 AMPS	MATERIALS STEEL STAINLESS STEEL BRASS ALUMINUM	GAS COMPRESSOR INCLUDED		
<b>Cutmaster® 42</b> 1-4200	CC THICKNESS 1/4" (6 mm)	MAX THICKNESS 5/8" (15 mm) WITH OPTIONAL TIPS	INPUT POWER 15 AMP 115 VAC	INPUT POWER 20 AMP 115 VAC	GENERATOR 3500 WATTS	OUTPUT 27 AMPS	PHASE 1 PH	CURRENT DC	DUTY CYCLE 30% @27 AMPS	MATERIALS STEEL STAINLESS STEEL BRASS ALUMINUM	GAS 75 PSI (5.2 bar) 3.2 CFM (91 l/m)	
	CC THICKNESS 3/8" (10 mm)	MAX THICKNESS 7/8" (22.2 mm) WITH OPTIONAL TIPS	INPUT POWER 50 AMP 208/230 VAC	GENERATOR 4000 WATTS	OUTPUT 40 AMPS	DUTY CYCLE 40% @40 AMPS						
<b>Cutmaster® 52</b> 1-5130-1	CC THICKNESS 1/2" (12.7 mm)	MAX THICKNESS 1 1/8" (30 mm) WITH OPTIONAL TIPS	INPUT POWER 50 AMP 208/230 VAC	GENERATOR 10,000 WATTS	OUTPUT 45 AMPS (230V, 1PH) 24 AMPS (230V, 3PH) 16 AMPS (460V, 3PH)			PHASE 3 PH	CURRENT DC	DUTY CYCLE 40% @60 AMPS	MATERIALS STEEL STAINLESS STEEL BRASS ALUMINUM	GAS 75 PSI (5.2 bar) 6.7 CFM (190 l/m)
			INPUT POWER CUSTOM INSTALL 460 VAC	GENERATOR 11,000 WATTS	OUTPUT 45 AMPS (230V, 1PH) 24 AMPS (230V, 3PH) 16 AMPS (460V, 3PH)							
<b>Cutmaster® 82</b> 1-1130-1	CC THICKNESS 3/4" (20 mm)	MAX THICKNESS 1 1/2" (40 mm) WITH OPTIONAL TIPS	INPUT POWER CUSTOM INSTALL 208/230 VAC	GENERATOR 17,000 WATTS	OUTPUT 72 AMPS (230V, 1PH) 39 AMPS (230V, 3PH) 21 AMPS (460V, 3PH)			PHASE 3 PH	CURRENT DC	DUTY CYCLE 40% @80 AMPS	MATERIALS STEEL STAINLESS STEEL BRASS ALUMINUM	GAS 70 PSI (4.8 bar) 6.7 CFM (190 l/m)
			INPUT POWER CUSTOM INSTALL 460 VAC	GENERATOR 18,000 WATTS	OUTPUT 72 AMPS (230V, 1PH) 39 AMPS (230V, 3PH) 21 AMPS (460V, 3PH)							



### Victor Thermal Dynamics® AirCut™ 15C

#### Specifications

Part No.	Description
1-1110-1	Victor Thermal Dynamics AirCut 15C <i>*Available in USA only</i>

#### FEATURES

- Comes standard with a built-in air compressor.
- Weighs only 29 lbs (13.2 kg), almost 50% lighter than the competition.
- 1/8" (3 mm) Recommended Cut, 3/16" (5 mm) maximum capability.
- 120V, 15 Amp plug standard. Plug it in anywhere!
- 25% more cutting power provides 25% faster cut speeds than the competition.

<b>CC THICKNESS</b>  <b>1/8"</b> (3 mm)	<b>MAX THICKNESS</b>  <b>3/16"</b> (5 mm) <small>WITH OPTIONAL TIPS</small>	<b>OUTPUT</b> <b>15 AMPS</b>	<b>INPUT POWER</b> <b>15 AMP</b> <b>115 VAC</b>
<b>PHASE</b> <b>1 PH</b>	<b>DUTY CYCLE</b> <b>35%</b> <small>@15 AMPS</small>	<b>MATERIALS</b> <b>STEEL</b> <b>STAINLESS STEEL</b> <b>BRASS</b> <b>ALUMINUM</b>	<b>GENERATOR</b> <b>2,000 WATTS</b>

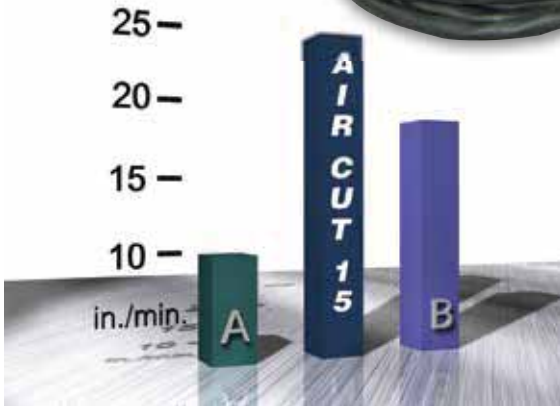

Cut Speed Comparison 1/8" (3 mm)

MACHINE SPECIFICATIONS	
<b>Cut Capacity</b>	1/8" (3 mm) Recommended Cut
<b>Output Current</b>	15 Amps Fixed
<b>Input Power</b>	120V (± 10%), Single Phase, 60 Hz, 12 Amps
<b>Duty Cycle</b>	35% @ 15A
<b>Dimensions</b>	Length 18" (457 mm) Width 6.5" (165 mm) Height 9.5" (241 mm)
<b>Weight</b>	29 lbs (13.2 kg)
<b>Ship Weight</b>	38 lbs (17.2 kg) (includes Unit, Power Cable, Torch and Leads)
<b>Work Cable</b>	19.5 ft (5.9 m)
<b>Input Cable</b>	8.5 ft. (2.6 m)
<b>Gas Type</b>	Air from Built-In Air Compressor
<b>Pilot</b>	CD Start
<b>Control</b>	Hand Torch Switch
<b>Torch</b>	PCH-10
<b>Torch Configuration</b>	Hand 70°, 20' (6.1 m) Leads

### AirCut 15C Parts and Accessories

#### Specifications

Part No.	Accessories
2-1020	PCH-10 70° Torch / 20' (6.1 m) Leads
7-8910	Cutting Guide Kit
9-1260	20 ft (6.1 m) Leather Leads Cover
9-6003	Shield Cup
9-6099	Tip
9-6007	Gas Distributor
9-6006	Electrode





### Thermal Dynamics® Cutmaster® 42

#### Specifications

Part No.	Description
1-4200	Thermal Dynamics Cutmaster 42
1-4200-7	Thermal Dynamics Cutmaster 42 (Canadian CSA Approved)

**APPLICATIONS**

Auto Body/Marine Repair, Plumbing & HVAC, Home Shop, Metal Building & Roofing Construction, Rental Fleets

**FEATURES**

- Weighs only 26 lbs (11.8 kg)
- 1/4" (6 mm) Recommended Cut, 7/8" (12 mm) Max Cut
- 230V Plug with two adapters: 120V 15Amp and 120V 20Amp

<b>CC THICKNESS</b> 3/8" (10 mm)	<b>INPUT POWER</b> 20 AMP 115 VAC	<b>OUTPUT</b> 27 AMPS	<b>DUTY CYCLE</b> 30% @27 AMPS	<b>GENERATOR</b> 3,500 WATTS	<b>GAS</b> 75Psi (5.2 bar) 3.2 CFM (91 l/m)
<b>MAX THICKNESS</b> 7/8" (22.2 mm) WITH OPTIONAL TIPS	<b>INPUT POWER</b> 50 AMP 208/230 VAC	<b>OUTPUT</b> 40 AMPS	<b>DUTY CYCLE</b> 40% @40 AMPS	<b>GENERATOR</b> 4,000 WATTS	<b>MATERIALS</b> STEEL STAINLESS STEEL BRASS ALUMINUM



The TRUE™ Series Cutmaster 42 is one of the most affordable, highest quality 1/4" (6 mm) plasma systems on the market. As part of the TRUE Series, you can rely on the Cutmaster 42 to cut all day at its recommended cutting capacity and to pack more punch when you need it.

The Cutmaster 42 incorporates Vent2Shield™ technology allowing the use of a considerably smaller compressor (less weight to carry, can be used with 120V) compared to similar 40A units.

**FOUR YEAR** **4** **WARRANTY**

**VENT2SHIELD**  
TECHNOLOGY

PLASMA

MACHINE SPECIFICATIONS	
<b>Max Amperage Output</b>	27A @ 120V 40A @ 230V
<b>Output Power</b>	3.8 kW
<b>Recommended Cut</b>	1/4" (6 mm)
<b>Max Cut</b>	7/8" (12 mm)
<b>Pierce Rating</b>	1/4" (6 mm)
<b>Input Voltage (Volts, Phase, Hz)</b>	120-230V, 1 Phase, 50/60 Hz
<b>Duty Cycle (@40°C)</b>	40% @ 40A @ 230V
<b>Amperage Draw</b>	29A @ 120V 15A @ 230V
<b>Dimensions (H x W x L)</b>	9" x 7" x 18.5" (228 mm x 117 mm x 470 mm)
<b>Weight</b>	26 lbs (11.8 kg)
<b>Torch Model</b>	SL40™
<b>Air Pressure</b>	75 psi (5.2 bar)
<b>Flow</b>	3.2 cfm (91 l/m)
<b>Warranty (Unit/Torch) Parts and Labor</b>	4/1
<b>Approvals</b>	CSA, ETL

#### Graph Key

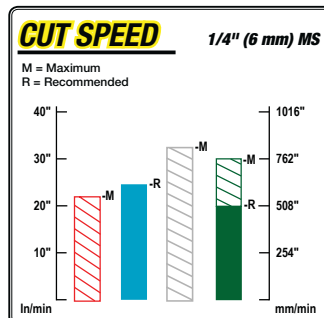
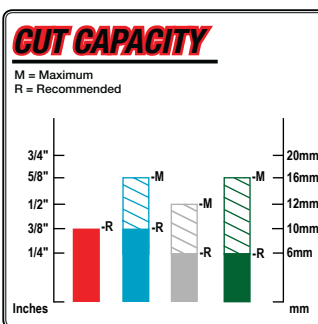

CUTMASTER TRUE SERIES

# 42

RECOMMENDED CUT

## 1/4"

MAXIMUM CUT

# 7/8"

150% MORE PUNCH

WHEN YOU NEED IT.



### Thermal Dynamics® Cutmaster® 52

#### Specifications

Part No.	Description
1-5130-1	Thermal Dynamics Cutmaster 52

**APPLICATIONS**

Construction, Maintenance/Repair & Fabrication

**FOUR YEAR 4 WARRANTY**

<b>CC THICKNESS</b> 1/2" (12.7mm)	<b>MAX THICKNESS</b> 1 1/8" (30 mm) WITH OPTIONAL TYP	<b>OUTPUT</b> 45AMPS (230V,1PH) 24AMPS (230V,3PH) 16AMPS (460V,3PH)	<b>INPUT POWER</b> 50 AMP 208/230 VAC
<b>INPUT POWER</b> CUSTOM INSTALL 460 VAC	<b>DUTY CYCLE</b> 40% @60 AMPS	<b>MATERIALS</b> STEEL STAINLESS STEEL BRASS ALUMINUM	<b>GENERATOR</b> 11,000 WATTS

The Cutmaster 52 is the most powerful and lightest weight 1/2" (12 mm) machine on the market today.

The Cutmaster TRUE™ Series are the only systems that offer the precision of the TRUE Cut Drag Tip Series. The 60 Amp tip allows the system to drag cut up to 1/4" (6 mm) with ease. Giving the absolute best cut quality possible.

This unit cuts through mild, stainless, or aluminum up to 1.125" (30 mm) thick. The Cutmaster 52 combines power with the well known performance and features of the industry-leading 1Torch®.



PLASMA

MACHINE SPECIFICATIONS	
Max Amperage Output	60A
Output Power	6.2 kW
Recommended Cut	1/2" (12 mm)
Max Cut	1 1/8" (30 mm)
Pierce Rating	1/2" (12 mm)
Input Voltage (Volts, Phase, Hz)	<ul style="list-style-type: none"> <li>208/230V - 460V 1/3 ph 50/60 Hz</li> <li>400V 3 ph 50 Hz</li> <li>600V 3 ph 50/60 Hz</li> </ul>
Duty Cycle (@40°C)	40% @ 60A, 60% @ 55A, 100% @ 50A
Amperage Draw	45 (230V, 1 ph) 24 (230V, 3 ph) 16 (460V, 3 ph)
Dimensions (H x W x L)	15" x 12" x 24" (381 mm x 305 mm x 610 mm)
Weight	43 lbs (19.5 kg)
Torch Model	SL60 Hand SL100 Mechanized
Air Pressure	75 psi (5.2 bar)
Flow	6.7 cfm (190 l/m)
Warranty (Unit/Torch) Parts and Labor	4/1
Approvals	CSA, ETL

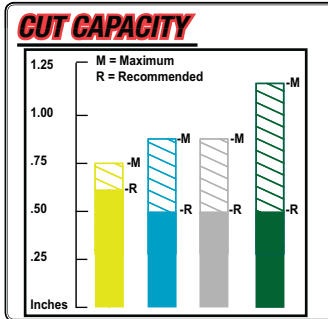

Graph Key

- Competitor A
- Competitor B
- Competitor C
- TD

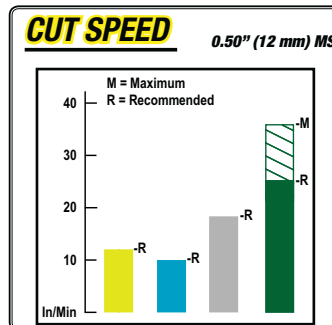

CUTMASTER TRUE SERIES

# 52

RECOMMENDED CUT  
**1/2"**

MAXIMUM CUT  
**1 1/8"**

**125%**  
MORE PUNCH  
WHEN YOU NEED IT.

### Thermal Dynamics® Cutmaster® 82

#### Specifications

Part No.	Description
1-1130-1	Thermal Dynamics Cutmaster 82
<b>APPLICATIONS</b>	
Heavy Fabrication, Manufacturing & Contractors	

**FOUR YEAR 4 WARRANTY**

<b>CC THICKNESS</b> 3/4" (20 mm)	<b>MAX THICKNESS</b> 1 1/2" (40 mm) WITH OPTIONAL TIPS	<b>OUTPUT</b> 72AMPS (230V, 1PH) 39AMPS (230V, 3PH) 21AMPS (460V, 3PH)	<b>INPUT POWER</b> CUSTOM INSTALL 208/230 VAC
<b>INPUT POWER</b> CUSTOM INSTALL 460 VAC	<b>DUTY CYCLE</b> 40% @ 80 AMPS	<b>MATERIALS</b> STEEL STAINLESS STEEL BRASS ALUMINUM	<b>GENERATOR</b> 18,000 WATTS

The Cutmaster 82 weighs in at a mere 43 lbs (19.5 kg) almost 50% less than its leading competitor, while still offering superior cutting power.

Don't let the size of this unit fool you, it's more than capable of cutting 3/4" (20 mm) with a maximum capability of 1 1/2" (40 mm).

This unit, like all other TRUE™ Cutmasters, is equipped with the 1Torch®.



MACHINE SPECIFICATIONS	
<b>Max Amperage Output</b>	80A
<b>Output Power</b>	9 kW
<b>Recommended Cut</b>	3/4" (20 mm)
<b>Max Cut</b>	1 1/2" (40 mm)
<b>Pierce Rating</b>	5/8" (15 mm)
<b>Input Voltage - (Volts, Phase, Hz)</b>	<ul style="list-style-type: none"> <li>208/230V - 460V 1/3 ph 50/60 Hz</li> <li>400V 3 ph 50 Hz</li> <li>600V 3 ph 50/60 Hz</li> </ul>
<b>Duty Cycle (@40°C)</b>	40% @ 80A, 60% @ 65A 100% @ 55A
<b>Amperage Draw</b>	72 (230V, 1 ph) 39 (230V, 3 ph) 21 (460V, 3 ph)
<b>Dimensions (H x W x L)</b>	15" x 12" x 24" (381 mm x 305 mm x 610 mm)
<b>Weight</b>	43 lbs (19.5 kg)
<b>Torch Model</b>	SL60 Hand SL100 Mech & Auto
<b>Air Pressure</b>	70 psi (4.8 bar)
<b>Flow</b>	6.7 cfm (190 bar)
<b>Warranty (Unit/Torch) Parts and Labor</b>	4/1
<b>Approvals</b>	CSA, ETL

#### Graph Key

- Competitor A
- Competitor B
- Competitor C
- Competitor D
- TD

#### CUT CAPACITY

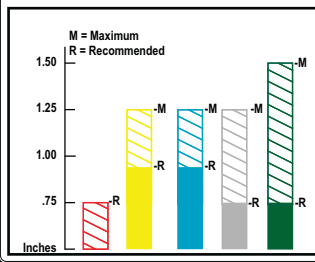

#### CUT SPEED

0.750" (20 mm) MS

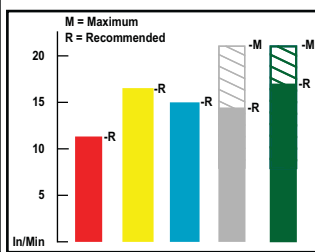

CUTMASTER TRUE SERIES

# 82

RECOMMENDED CUT

## 3/4"

MAXIMUM CUT

# 1 1/2"

100% MORE PUNCH WHEN YOU NEED IT.

### Welding/Cutting Cart

#### Specifications

Part No.	Description
1444-0407	Welding/Cutting Cart



#### FEATURES

- Fits Many Firepower Welders/Cutters (not MST 220i)
- Accommodates up to 9" (229 mm) diameter Cylinder with Included Chain
- Holds Welders/Cutters on Top Tray
- Sturdy and Durable Construction

#### FOR USE WITH

MST 140i & 180i, FP-95, 125, 135, 165  
 Thermal Arc 95 S, TIG 160S, TIG 140 ACDC & 200 ACDC  
 Cutmaster 42, AirCut 15C, Fabricator 141i & 181i

### Basic Utility Cart

#### Specifications

Part No.	Description
1444-0900	Basic Utility Cart



#### FEATURES

- Sturdy handle makes transporting welders/cutters easy
- Designed for most portable Welding/Cutting systems
- Rugged Solid Steel Construction
- Easy-rolling 8" (203 mm) diameter wheels
- 3" (76 mm) front-mounted casters
- Accommodates up to 9" (229 mm) diameter Cylinder with Included Chains

#### FOR USE WITH

MST 140i, 180i, 220i, FP-95, 125, 135, 165  
 Thermal Arc 95 S, TIG 160S, TIG 140 ACDC & 200 ACDC  
 Cutmaster 42, 52, 82, CutSkill C-20A, C-35A, C-70A  
 AirCut 15C, Fabricator 141i, 181i, & 211i, Fabricator 186 ACDC

### Deluxe Welding/Cutting Cart

#### Specifications

Part No.	Description
1444-0901	Deluxe Welding/Cutting Cart



#### FEATURES

- Single Cylinder Rack Accommodates up to 9" (229 mm) diameter Cylinder
- Large Accessory Drawer and Consumable Compartment
- Includes MIG/TIG Parts Storage Box
- Rugged Solid Steel Construction
- Designed for Most Firepower Welders/Cutters
- Includes Chain for Holding Tank

#### FOR USE WITH

MST 140i, 180i, 220i, FP-95, 125, 135, 165  
 Thermal Arc 95 S, TIG 160S, TIG 140 ACDC & 200 ACDC  
 Cutmaster 42, 52, 82, CutSkill C-20A, C-35A, C-70A  
 AirCut 15C, Fabricator 141i, 181i, & 211i, 252i, Fabricator 186 ACDC

### Cutmaster® 42 / 52 / 82 Parts and Accessories

#### Specifications



Current Range	Mode Of Operation	Amps	Electrode	Start Cartridge	Tip	Shield Cup	Shield Cup Body	Drag Shield Cap	Deflector	Gouging Shield Cap	
<b>SL40™ Consumables (for use with Cutmaster® 42)</b>											
<b>10-40 Amps</b>	Standoff Cutting	40A	9-0096	9-0097	9-0094	9-0098					
	Drag Tip / Cutting	20A			9-0091						
	Drag Tip / Cutting	40A			9-0093						
<b>SL60® and SL100® Consumables</b>											
<b>20-40 Amps</b>	Drag Tip / Cutting	20A	9-8215	9-8213	9-8205	9-8218					
		30A			9-8206	9-8218					
		40A			9-8207	9-8218					
		20A			9-8205	9-8237					9-8243
	Standoff Cutting	30A			9-8206	9-8237	9-8243				
		40A			9-8207	9-8237	9-8243				
		40A			9-8208	9-8218	9-8237	9-8243	9-8241		
Gouging	Tip A	9-8208	9-8237	9-8243							
<b>50-60 Amps</b>	Drag Tip / Cutting	60A	9-8215	9-8213	9-8252	9-8218					
		50-55A			9-8209	9-8218					
	Standoff Cutting	60A			9-8210	9-8218	9-8237	9-8243			
		50-55A			9-8209	9-8237					
		60A			9-8210	9-8237					
	Drag Shield Cutting	50-55A			9-8209	9-8237	9-8235	9-8243			
		60A			9-8210	9-8237	9-8235				
Gouging	Tip B	9-8226	9-8237		9-8241						
	Tip C	9-8227	9-8237		9-8241						
	Tip D	9-8228	9-8237		9-8241						
<b>70-100 Amps</b>	Standoff Cutting	70A	9-8215	9-8213	9-8231	9-8218					
		80A			9-8211	9-8218					
		90-100A			9-8212	9-8218					
		70A			9-8231	9-8237					9-8243
		80A			9-8211	9-8237					9-8243
	Drag Shield Cutting	90-100A			9-8212	9-8237	9-8243				
		70A			9-8231	9-8237	9-8236				
		80A			9-8211	9-8237	9-8236				
	Gouging	90-100A			9-8212	9-8237	9-8236				
		Tip B			9-8226	9-8237		9-8241			
Tip C		9-8227	9-8237		9-8241						
Tip D		9-8228	9-8237		9-8241						
<b>120 Amps</b>	Standoff Cutting	120A	9-8215	9-8213	9-8253	9-8237	9-8237	9-8258	9-8243		
	Drag Shield Cutting	120A			9-8253	9-8237			9-8243		
	Gouging	Tip E			9-8254	9-8237			9-8243		9-8241



### Filler Metal



### Firepower® Products

#### Performance, Value and Ease of Use

Firepower welding and safety products cover a full range of metalworking equipment needs. When you choose Firepower, you can be sure you're getting premium, quality tools and equipment with a proven record of performance and dependability. With Firepower's full line of accessories, you've got everything you need in welding, cutting and safety.

### Safety



### Accessories



## STICK WELDING (SMAW)

AWS CLASS	POSITION	POLARITY	USAGE
	All	AC, DCEP	All-purpose stick electrode; used for carbon and galvanized steel; deep penetration and ideal for welding light to medium amounts of dirty, rusty or painted materials; 60,000 PSI tensile strength.
	All	AC, DCEN, DCEP	Light to medium penetrating all-purpose stick electrode; for use on carbon steel; good for general all-purpose applications and joints with poor fit-up; 60,000 PSI tensile strength.
	All	AC, DCEN, DCEP	For higher-deposition requirements; ideal for applications requiring light penetration and faster travel speeds; 70,000 PSI tensile strength.
	All	DCEP	Low-hydrogen electrode; for low, medium and high-carbon steels; ideal for out-of-position welding and tacking; not recommended for low-voltage AC Welders; 70,000 PSI tensile strength.

## ELECTRODE AMPERAGE CHART

AWS CLASS	DIA. (IN.)	AMPERAGE RANGE					MAX.
		MIN.	50A	100A	150A	200A	
	3/32		1/16" - 1/4" *				
	1/8			1/8" - 1/2" *			
	5/32				1/4" - Up *		
	5/64	Min. - 1/8" *					
	3/32		1/16" - 1/4" *				
	1/8			1/8" - 1/2" *			
	5/32				1/4" - Up *		
	3/32			1/16" - 1/4" *			
	1/8				1/8" - 1/2" *		
	5/32					1/4" - Up *	
	3/32			1/16" - 1/4" *			
	1/8				1/8" - 1/2" *		

\*Plate Thickness

### Carbon Steel

Carbon steel, or plain-carbon steel, is mostly iron and carbon with other elements in quantities too small to affect their properties. A low carbon content means it is similar to iron, soft, and easily formed. The more carbon content, the harder and stronger the metal becomes, but it is also less moldable and harder to weld. At a higher carbon content, the metal's melting point is lower and it has less resistance to higher temperatures. Such steel should not be used in an environment where sparks would pose a potential safety problem.

### Stainless Steel

Stainless steel contains a high chromium and low carbon content, and upon contact with oxygen creates a chromium oxide layer that gives passive protection against corrosion from moisture. When certain high-strength alloys such as aluminum come into contact with carbon steel, such as being brushed by carbon steel wire, a deposit of carbon steel is left behind that can cause rust. That same carbon steel transfer can happen in the other direction, which is why once a stainless steel brush is used on carbon steel it should never be used on stainless steel again. Also, stainless steel brushes should be stored away from any area that might contain carbon steel particles, such as a steel workbench. Stainless steel wire brushes should be degreased before operation, and if they are stored after use they should be degreased and wrapped in plastic. If they are stored without protection, their magnetic properties could allow particles to be collected that lead to after-rust.

## ELECTRODE PART NUMBER CHART

Rod Size	1 lb Box	5 lb Box	10 lb Box	50 lb Box
<b>TYPE 6011 STICK ELECTRODE</b>				
3/32"	1440-0115	1440-0116	1440-0117	1440-0118
1/8"	1440-0105	1440-0106	1440-0107	1440-0108
5/32"	1440-0095	1440-0096	1440-0097	1440-0098
<b>TYPE 6013 STICK ELECTRODE</b>				
3/32"	1440-0145	1440-0146	1440-0147	1440-0148
1/8"	1440-0134	1440-0135	1440-0136	1440-0137
5/32"	1440-0124	1440-0125	1440-0126	1440-0127
<b>TYPE 7014 STICK ELECTRODE</b>				
3/32"	1440-0205	1440-0206	1440-0207	1440-0208
1/8"	1440-0200	1440-0201	1440-0202	1440-0203
5/32"	1440-0150	1440-0151	1440-0152	1440-0153
<b>TYPE 7018 STICK ELECTRODE</b>				
3/32"	1440-0195	1440-0196	1440-0197	1440-0198
1/8"	1440-0185	1440-0186	1440-0187	1440-0188
5/32"	1440-0180	1440-0181	1440-0182	1440-0183
Rod Size	1 lb Box	5 lb Box	10 lb Box	Job Pack <sup>†</sup>
<b>E6024 QUICK START ELECTRODE</b>				
1/16"	1440-0412	1440-0413		
<b>308 STAINLESS STEEL ELECTRODE</b>				
3/32"	1440-0165			
1/8"	1440-0155	1440-0156		
<b>E-309L STAINLESS STEEL ELECTRODE</b>				
3/32"			1440-0497	
1/8"			1440-0496	
<b>NICKEL 55 CAST IRON</b>				
3/32"				1440-0440
1/8"	1440-0083			
<b>NICKEL 99 CAST IRON</b>				
3/32"				1440-0423
1/8"	1440-0425	1440-0374		1440-0424
<b>E4043 ALUMINUM ARC ELECTRODE</b>				
1/8"	1440-0419	1440-0420		

<sup>†</sup> See Page 59 for Job Packs Available  
<sup>‡</sup> For 230V Operation Only

## ELECTRODE DESCRIPTIONS

### TYPE 6011 Mild Steel Current: AC/DC

All position electrode. Use when you are unable to prepare a welding surface. Its deep penetration allows welds through rust, scale, oil and dirt.



### TYPE 6013 Mild Steel Current: AC/DC

All position electrode. Best used with clean or prepared welding surface. Excellent for low heat applications designed for general purpose.



### TYPE 7014 Iron Powder Current: AC/DC

All position electrode. Best used with clean or prepared welding surface with Medium to Low penetration. Designed for high deposition and high electrode travel speed.



### TYPE 7018 Low Hydrogen Current: AC/DC

All position electrode. Best used with clean or prepared welding surface with Medium penetration. Designed to produce X-ray quality welds.



### E6024 Quick Start Mild Steel Current: AC/DC

Best used with clean or prepared welding surface and excellent for low heat applications. Flat & horizontal fillet only.



### 308 Stainless Steel Current: AC/DC

Used for all 200 and 300 series stainless up to and including 308. Provides equal or better corrosion resistance than base metal and can also be used to fabricate and repair austenitic manganese steel.



### E-309L Current: AC/DC

Used for welding/joining of 300 series stainless to mild steel. Provides equal or better corrosion resistance than base metal.



### Nickel 55 Cast Iron Current: AC/DC\*

Best used for repairing cast iron/ heavy cast iron selections. Repairs cylinder blocks, exhaust manifold, and machines bases. Smooth arc characteristics produce strong welds at low amps.



### Nickel 99 Cast Iron Current: AC/DC\*

All position electrode. Best used on cast iron parts that are subject to heating and cooling, such as engine blocks, cylinder heads, exhaust manifolds.



### E4043 Aluminum Arc Current: DC

Best used for weld with strength ductility and corrosion resistance equal to parent metal. Applications include aluminum, sheet metal, plates, castings, tanks and piping.



\*DC Recommended

ELECTRODES	MST 140i	MST 180i	MST 220i	TIG 140 ACDC	TIG 200 ACDC	TIG 160S
	Up to 3/32"	Up to 5/32"	Up to 5/32"	Up to 3/32"	Up to 5/32"	Up to 5/32"
Type 6011 Mild Steel	NO	EXPERT	EXPERT	NO	EXPERT	EXPERT
Type 6013 Mild Steel	NOVICE	NOVICE	NOVICE	NOVICE	NOVICE	NOVICE
Type 7014 Iron Powder	NOVICE	NOVICE	NOVICE	NOVICE	NOVICE	NOVICE
Type 7018 Low Hydrogen	SKILLED	SKILLED	SKILLED	SKILLED	SKILLED	SKILLED
E6024 Quick Start	NOVICE	NOVICE	NOVICE	NOVICE	NOVICE	NOVICE
308 Stainless Steel	NOVICE	NOVICE	NOVICE	NOVICE	NOVICE	NOVICE
E-309L Stainless Steel	NOVICE	NOVICE	NOVICE	NOVICE	NOVICE	NOVICE
Nickel 55 Cast Iron	NOVICE	NOVICE	NOVICE	NOVICE	NOVICE	NOVICE
Nickel 99 Cast Iron	NOVICE	NOVICE	NOVICE	NOVICE	NOVICE	NOVICE
E4043 Aluminum Arc	EXPERT	EXPERT	EXPERT	EXPERT	EXPERT	EXPERT

Each electrode is unique and when working with different materials (Steel, Stainless Steel, Cast Iron, etc.) they require different preparations. We recommended researching the proper welding preparation guidelines for the materials before welding.



These easy-to-use electrodes are multi-position electrodes and are simple to use when welding. Little preparation time, forgivable arc lengths, and wide range of techniques are possible with these electrodes.



Using the intermediate electrodes will require some skill. The electrodes and metals you're working with will require more preparation before welding and require you to maintain the Arc Length.



Professional welding skills are needed to use these electrodes. These electrodes require precision while welding, as there is minimal leeway for operator error, and unique techniques may be required.



### Arc Welding Electrodes



Type 6010	1 lb Box	5 lb Box	10 lb Box	50 lb Box
ROD SIZE	PART NO.	PART NO.	PART NO.	PART NO.
3/32"	N/A	1440-0474	N/A	N/A
1/8"	N/A	1440-0473	1440-0476	1440-0093
5/32"	N/A	1440-0475	N/A	N/A

Type 6011	1 lb Box	5 lb Box	10 lb Box	50 lb Box
ROD SIZE	PART NO.	PART NO.	PART NO.	PART NO.
3/32"	1440-0115	1440-0116	1440-0117	1440-0118
1/8"	1440-0105	1440-0106	1440-0107	1440-0108
5/32"	1440-0095	1440-0096	1440-0097	1440-0098

Type 6013	1 lb Box	5 lb Box	10 lb Box	50 lb Box
ROD SIZE	PART NO.	PART NO.	PART NO.	PART NO.
3/32"	1440-0145	1440-0146	1440-0147	1440-0148
1/8"	1440-0134	1440-0135	1440-0136	1440-0137
5/32"	1440-0124	1440-0125	1440-0126	1440-0127

Type 7014	1 lb Box	5 lb Box	10 lb Box	50 lb Box
ROD SIZE	PART NO.	PART NO.	PART NO.	PART NO.
3/32"	1440-0205	1440-0206	1440-0207	1440-0208
1/8"	1440-0200	1440-0201	1440-0202	1440-0203
5/32"	1440-0150	1440-0151	1440-0152	1440-0153

Type 7018	1 lb Box	5 lb Box	10 lb Box	50 lb Box
ROD SIZE	PART NO.	PART NO.	PART NO.	PART NO.
3/32"	1440-0195	1440-0196	1440-0197	1440-0198
1/8"	1440-0185	1440-0186	1440-0187	1440-0188
5/32"	1440-0180	1440-0181	1440-0182	1440-0183

#### 6010 FEATURES

- Premium AWS Class E-6010
- Mild steel type
- Deep penetration, welds through rust, scale, oil and dirt
- Excellent for pipe welding, root
- DC, reverse polarity
- 60,000 PSI tensile strength
- All position electrode

#### 6011 FEATURES

- Premium AWS Class E-6011
- Mild steel type
- Deep penetration, welds through rust, scale, oil and dirt
- Use when you are unable to prepare the welding surface
- AC or DC, reverse polarity
- 60,000 PSI tensile strength
- All position electrode

#### 6013 FEATURES

- Premium AWS Class E-6013
- Mild steel type
- Designed for General Purpose
- Excellent for low heat applications
- Best used with clean or prepared welding surface
- AC or DC, reverse polarity
- 60,000 PSI tensile strength
- All position electrode

#### 7014 FEATURES

- Premium AWS Class E-7014
- Iron powder type
- Designed for high deposition and high electrode travel speed
- Medium to low penetration
- Best used with clean or prepared welding surface
- AC or DC, reverse polarity
- 70,000 PSI tensile strength
- All position electrode

#### 7018 FEATURES

- Premium AWS Class E-7018
- Low Hydrogen Type
- Designed to produce X-Ray quality welds
- Medium penetration
- Best used with clean or prepared welding surface
- AC or DC, either polarity
- 70,000 PSI tensile strength
- All position electrode

### Job Packs

#### Specifications

Part No.	Description	No. Rods
1440-0400	Bronze Flux Coated Brazing Rods, 3/32" diameter x 14" long; No brazing flux needed	4
1440-0401	Bronze Bare Brazing Rods, 3/32" diameter x 14" long; Requires brazing flux	4
1440-0402	E4043 Aluminum Welding Electrodes, 1/8" diameter x 14" long; Use with ANY Aluminum Application	3
1440-0404	Steel Welding Electrodes, 3/32" diameter x 14" long; Excellent problem solver type electrode	4
1440-0405	<b>6013</b> General Purpose Electrodes, 1/16" x 10" long	4
1440-0406	<b>6013</b> General Purpose Electrodes, 3/32" diameter x 14" long; Excellent for use with all types of Arc Welders	4
1440-0409	<b>6011</b> Welding Electrodes, 1/8" diameter x 14" long; Excellent for Maintenance & Repair Applications	3
1440-0411	Nickel 55 Welding Electrodes, 1/8" diameter x 14" long	4
1440-0423	ENiCl Pure Nickel Electrode 3/32" diameter x 14" long	5
1440-0424	ENiCl Pure Nickel Electrode 1/8" diameter x 14" long	3
1440-0440	Cast Iron (55% Nickel) 3/32" diameter x 14" long	3
1440-0441	<b>6011</b> Mild Steel 3/32" diameter x 14" long	4



## Mild Steel / E6024 Quick Start Electrodes

### Specifications

Part No.	Description
1440-0412	1/16" 1 lb
1440-0413	1/16" 5 lbs

### APPLICATIONS

Mild steel type electrode has a special quick start tip. Stable arc and automatic action that makes it easy to use on thin metals requiring low amperage. Features self-cleaning action that works well in all positions. Tensile Strength 60,000 PSI.

CURRENT	AC/DC	
AMPERAGE RECOMMENDATIONS	AMPS	DIAMETER
	25-90	1/16"



## Stainless Steel / 308 Stainless Steel Electrodes

### Specifications

Part No.	Description
1440-0165	3/32" x 14" 1 lb box
1440-0155	1/8" x 14" 1 lb box
1440-0156	1/8" x 14" 5 lbs box

### FEATURES

- For welding all 200 and 300 series stainless up to and including 308
- Provides equal or better corrosion resistance than the base metal
- Can be used for fabricating and repairing austenitic manganese steel



## Stainless Steel / E-309L

### Specifications

Part No.	Description
1440-0497	3/32" x 14" 10 lb box
1440-0496	1/8" x 14" 10 lb box

### FEATURES

- For welding/joining of 300 series stainless to mild steel.
- Provides equal or better corrosion resistance than the base metal



## Nickel Base / Est Cast Iron Electrodes (Non-Machinable, Steel Core)

### Specifications

Part No.	Description
1440-0449	1/8" 1 lb
1440-0443	1/8" 5 lbs

### APPLICATIONS

This cast iron electrode is specifically developed for dirty and oil soaked cast iron applications. It is also ideal for heat affected cast iron repairs. This electrode offers the least expensive method of repairing cast iron. Great for repairing castings, transmission housings, etc. Non-Machinable. Tensile strength 62,000 PSI. Elongation 20%

<b>CURRENT</b>	AC/DC - DC+ recommended
<b>AMPERAGE RECOMMENDATIONS</b>	70-125 AMPS



## Nickel Base / ENiFeCl Nickel 55 Cast Iron Electrodes (Machinable)

### Specifications

Part No.	Description
1440-0440	3/32" Job pack (3 rods)
1440-0083	1/8" 1 lb

### APPLICATIONS

The most versatile cast iron electrode. The best solution for repairing cast iron, heavy cast iron sections. The smooth arc characteristics produce strong, sound welds at low amps. Repairs cylinder blocks, exhaust manifold, and machine bases. Tensile strength 70,000 PSI. Elongation 12%

<b>CURRENT</b>	AC/DC - DC+ recommended	
<b>AMPERAGE RECOMMENDATIONS</b>	<b>AMPS</b>	<b>DIAMETER</b>
	70-90	3/32"
	80-120	1/8"



## Nickel Base / ENiCl Pure Nickel 99% Cast Iron Electrodes (Machinable)

### Specifications

Part No.	Description
1440-0423	3/32" Job pack (5 rods)
1440-0424	1/8" Job pack (3 rods)
1440-0425	1/8" 1 lb
1440-0374	1/8" 5 lbs

### APPLICATIONS

The highest quality nickel electrode available. Welds well in all positions. The high (99%) nickel content has a natural attraction to cast iron giving it superior performance when welding cast iron material. Nickel 99 can be used on cast iron parts that are subject to heating and cooling, such as engine blocks, cylinder heads, exhaust manifolds, etc. Excellent machinability. Tensile strength 55,000 PSI. Elongation 10%

<b>CURRENT</b>	AC/DC - DC+ recommended	
<b>AMPERAGE RECOMMENDATIONS</b>	<b>AMPS</b>	<b>DIAMETER</b>
	70-90	3/32"
	70-110	1/8"





## Aluminum / E4043 Aluminum Arc Electrodes

### Specifications

Part No.	Description
1440-0419	1/8" 1 lb
1440-0420	1/8" 5 lbs

### APPLICATIONS

This flux coated aluminum electrode is designed to give a weld with strength ductility and corrosion resistance equal to parent metal. Applications include aluminum, sheet metal, plates, castings, tanks and piping. Tensile strength 34,000 PSI. Elongation 18%.

<b>CURRENT</b>	DC+	
<b>AMPERAGE RECOMMENDATIONS</b>	<b>AMPS</b>	<b>DIAMETER</b>
	70-120	1/8"



## Hardfacing Electrodes

### Specifications

Part No.	Description
1440-0080	1/8" 1 lb tube, #35 High Abrasion/Hardfacing
1440-0081	1/8" 5 lbs box, #35 High Abrasion/Hardfacing

### APPLICATIONS

This high quality, all purpose electrode produces outstanding impact and abrasion resistance. The high deposition rate prolongs surface life of new and worn parts. Ideal for repairing all types of agriculture, construction equipment, auger, buckets, concrete mixers, etc.

<b>AMPERAGE RECOMMENDATIONS</b>	<b>AMPS</b>	<b>DIAMETER</b>
	110-140	1/8"



## Cutting Electrodes

### Specifications

Part No.	Description
1440-0426	1/8" 1 lb

### APPLICATIONS

A special heavy duty coating produces 7000° heat at high-arc velocity. Use this electrode for a fast, low-cost means of cutting cast iron and stainless steel without special equipment.

<b>CURRENT</b>	AC
----------------	----



### Oxygen / Acetylene Mild Steel (Copper Coated)

#### Specifications

Part No.	Description
1440-0442	1/16" x 18" 5 lbs
1440-0433	3/32" x 36" 10 lbs

#### APPLICATIONS

Low carbon steel rod manufactured to the highest quality standards. Copper coating prevents rusting and improves corrosion resistance. A great rod for shop, home, commercial and maintenance repairs. 65,000 PSI tensile strength.



### Manganese Bronze Flux Coated Gas Rods

#### Specifications

Part No.	Description
1440-0431	3/32" x 36" 1 lb
1440-0429	3/32" x 36" 5 lbs
1440-0430	1/8" x 36" 5 lbs

#### APPLICATIONS

Flux coated, low fuming brazing rod. Provides all properties for best tensile strength and ductility. Rod fuses well with cast iron, malleable iron, galvanized iron, steel, brass and copper. 65,000 PSI tensile strength.

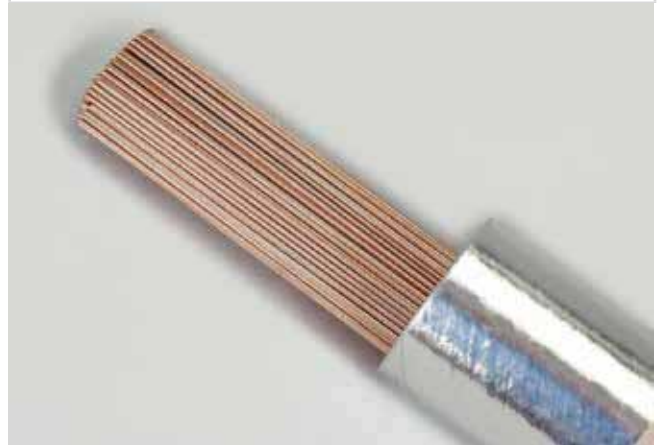

### Manganese Bronze Bare Gas Rods

#### Specifications

Part No.	Description
1440-0427	3/32" x 36" 5 lbs
1440-0428	1/8" x 36" 5 lbs

#### APPLICATIONS

Bare brazing rod low fuming highest quality. Balanced zinc and copper alloy. Excellent for brazing fenders, radiators, water tanks and sheet metal. 63,000 PSI tensile strength.



### Easy-Flo Aluminum Brazing Rods

#### Specifications

Part No.	Description
1440-0434	1/8" x 18" 1 lb

#### APPLICATIONS

Aluminum rod is excellent for all types of sheet or cast aluminum. This product greatly simplifies the process and requires no flux. Applications include aluminum boats, lawn equipment, outboard motors and castings.



### Solders and Fluxes / Acid Flux Core Solder

#### Specifications

Part No.	Description
1423-1102	Acid Flux Core, Comm.; 1/8" x 1 lb
1423-1109	Acid Flux Core, 30/70; 1/8" x .5 lb
1423-1108	Acid Flux Core, 40/60; 1/8" x .25 lb

#### APPLICATIONS

Is used for non-electrical applications. Applications include, Sheet Metal joint and fitting connections, works well on many types of metals (Copper, Brass, Nickel and Galvanized Steel).



### Solders and Fluxes / Rosin Flux Core Solder

#### Specifications

Part No.	Description
1423-1114	Rosin Flux Core, 40/60; 1/8" x 1 lb
1423-1113	Rosin Flux Core, 30/70; 3/32" x .5 lb
1423-1110	Rosin Flux Core, 40/60; 1/16" x .25 lb
1423-1112	Rosin Flux Core, 40/60; 3/32" x .25 lb

#### APPLICATIONS

Used for electrical applications. Completely non-corrosive and electrically non-conductive.



### Soldering Flux and Paste

#### Specifications

Part No.	Description
1423-1111	2 oz. Soldering Flux
1423-1101	2 oz. Soldering Paste

#### APPLICATIONS

Soft Soldering/Tinning Flux that is active between 200°F and 600°F. Very effective on copper and repairing automotive radiators.



### Arcair® Protex Plus Anti-Spatter Nozzle Shield

#### Specifications

Part No.	Description
1440-0296	Arcair Protex Plus Anti-Spatter Spray, 16 oz

#### FEATURES

- Prevents spatter adhesion on surface - reduces clean-up time
- Non-flammable - contains no silicones



### Mild Steel Solid Wire / ER70S-6 MIG Wire Solid

#### Specifications

Part No.	Spool Size	Wire Size
1440-0210	2 lbs	.023"
1440-0211	11 lbs	.023"
1440-0212	33 lbs	.023"
1440-0215	2 lbs	.030"
1440-0216	11 lbs	.030"
1440-0217	33 lbs	.030"
1440-0220	2 lbs	.035"
1440-0221	11 lbs	.035"
1440-0222	33 lbs	.035"
1440-0447	33 lbs	.045"

#### FEATURES

- Premium AWS CLASS ER70S-6
- For general purpose MIG welding
- Designed to be used on mild steel
- Best used with clean or prepared welding surface
- Requires a shielding gas
- DC reverse polarity



### Flux Cored Wire / E71T-GS Fluxed Cored

#### Specifications

Part No.	Spool Size	Wire Size
1440-0230	2 lbs	.030"
1440-0231	10 lbs	.030"
1440-0235	2 lbs	.035"
1440-0236	10 lbs	.035"

#### FEATURES

- Premium AWS CLASS E 71T-GS
- Also called "Self-Shielding" or "Gasless"
- For general purpose MIG welders
- Designed to be used on mild steel
- Best used with clean or prepared welding surface
- Requires no shielding gas
- DC straight polarity



### Stainless Steel Solid Wire / ER 308L MIG Wire

#### Specifications

Part No.	Spool Size	Wire Size
1440-0245	2 lbs	.030"
1440-0489	10 lbs	.030"

#### FEATURES

- Premium AWS CLASS ER308L
- For stainless steel MIG welding
- Best when used with a clean or prepared welding surface
- Requires a shielding gas
- DC reverse polarity



### Aluminum Solid Wire / ER5356 MIG Wire

#### Specifications

Part No.	Spool Size	Wire Size	AWS Class
1440-0240	1 lb	.030"	ER 5356
1440-0241	1 lb	.035"	ER 5356
1440-0445	3 lbs	.035"	ER 5356
1440-0456	1 lb	.030"	ER 4043

#### FEATURES

- For aluminum MIG welding
- Best when used with a clean or prepared welding surface
- Requires a shielding gas
- DC reverse polarity





### Premium Firepower Auto-Darkening Welding Helmets

#### Specifications

Part No.	Description
1441-0085	Firepower Pinstripes Auto-Darkening Welding Helmet
1441-0086	Firepower Piston & Plug Auto-Darkening Welding Helmet
1441-0087	Firepower Stars & Stripes Auto-Darkening Welding Helmet
1441-0088	Firepower Skull & Fire Auto-Darkening Welding Helmet



#### FEATURES

- Four Arc Sensors for High Response
- Automatically Turns from Light to Dark and Dark to Light
- Adjustable Welding Shade Levels from 9 to 13
- Light Shade DIN Level
- "Sensitivity" Control Range
- Selection for Process Mode
- Solar-Powered
- HELMET meets standards EN175, ANSI Z87.1-2010 and CSA Z94.3
- "Delay" Adjustable Controls



**HELMET ANGLE ADJUSTMENT**  
3 positions to select helmet angle for optimum comfort

**AUTO-DARKENING VARIABLE SHADE KNOB**  
on the left for "on the fly" adjustment

**"SENSITIVITY" KNOB**  
on the right (not visible in photo)



SMAW – 60 Amps or less PAW – 20 Amps or less PAC – 300 Amps or less	SHADE #9
SMAW – 60-160 Amps or less GMAW / FCAW – 60 Amps or less GTAW – 60 Amps or less PAW – 20-100 Amps or less	SHADE #10
GMAW / FCAW – 60-160 Amps or less	SHADE #11
SMAW – 160-250 GMAW / FCAW – 160-250 Amps or less GTAW – 50-150 Amps CAC-A – 500 Amps or less PAW – 100-400 Amps PAC – 300-400 Amps	SHADE #12
SMAW – 250-550 Amps GMAW / FCAW – 250-550 Amps GTAW – 150-500 Amps CAC-A – 500-1000 Amps PAW – 400-800 PAC – 400-800	SHADE #13

### Replacement Parts

#### Specifications

#	Part No.	Description
1	20891010	Front Cover Lens, WH41001-FL
2	20891026	Inside Cover Lens, WH41001-IL4
3	20891013	Shade/Sensitivity Knob, WH41001-KB
4	20891017	Headgear Knob, WH41001-BN
5	20891018	Filter Frame w/Screws, WH41001-FF
6	20891020	Headband, WH41001-HB
7	20891023	Headgear Assembly, WH41001-HG
Not Shown	20891024	Hard Hat Fixtures, WH41001-HH
Not Shown	20891025	Magnifying Lens Kit (2X Magnification), WH41001-ML

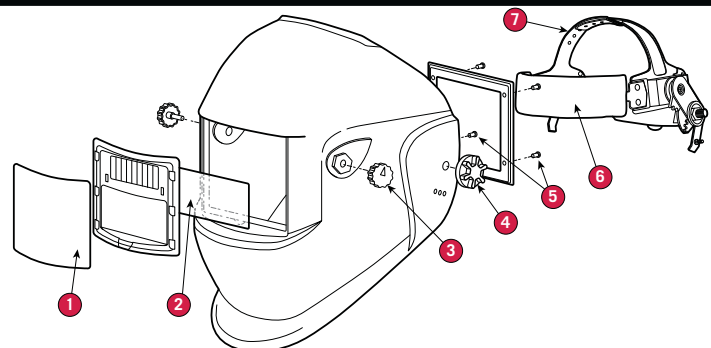

### Protective Eyewear

#### Specifications

Part No.	Description		FEATURES
1441-0042	Adjustable Ratchet Headgear		<ul style="list-style-type: none"> <li>Streamlined, compact design allows welders to get into tight places</li> <li>Meets or Exceeds: ANSI Z87-1, CE and various International Standards</li> </ul>
1441-0023	Fixed Front Helmet, 2" x 4.25" Economy, Black		<ul style="list-style-type: none"> <li>Streamlined, compact design allows welders to get into tight places</li> <li>Meets or Exceeds: ANSI Z87-1, CE and various International Standards</li> </ul>
1441-0038	Fixed Front Helmet, 4.5" x 5.25" Economy, Black		<ul style="list-style-type: none"> <li>Streamlined, compact design allows welders to get into tight places</li> <li>Meets or Exceeds: ANSI Z87-1, CE and various International Standards</li> </ul>
1441-0004	Lift/Fixed Front Combo Helmet, 4.5" x 5.25", Black		<ul style="list-style-type: none"> <li>Streamlined, compact design allows welders to get into tight places</li> <li>Meets or Exceeds: ANSI Z87-1, CE and various International Standards</li> </ul>
1423-4100	Hand Welding Shield, 2" x 4.25"		<ul style="list-style-type: none"> <li>Streamlined, compact design allows welders to get into tight places</li> <li>Meets or Exceeds: ANSI Z87-1, CE and various International Standards</li> </ul>

### Welding Protective Blanket and Equipment Cover

#### Specifications

Part No.	Description
1423-1404	Welding Blanket (38" x 24")

#### FEATURES

- Use our exclusive fiberglass fabric to protect equipment during welding, cutting, grinding and other potentially hazardous operations
- Service range up to 1000° F / 538° C, 20% higher than conventional welding fabrics
- Resistant to abrasion
- Fiberglass fabric can be draped over equipment or used as a curtain to isolate hazardous operations
- Grommets (36"-Centers) for versatility



### Welder's Gloves

#### Specifications

Part No.	Description
1423-0051	Durable Suede Leather Welder's Gloves

#### FEATURES

- Wing Thumb
- Partially Weltd Seams
- Full Sock Lining
- 14" Flared Gauntlet Cuff
- Self Hem
- Size: L



### Premium Welder's Gloves

#### Specifications

Part No.	Description
1423-4133	Sturdy Suede Leather Welder's Gloves

#### FEATURES

- Wing Thumb
- Fully Weltd Seams
- 100% Cotton Lining
- 14" Flared Gauntlet Cuff
- Self Hem
- Size: L



### Glass Filter Plates

#### Specifications

Part No.	Description	Size
1441-0047	Filter Plate, Shade #10	2" x 4.25"
1441-0049	Filter Plate, Shade #10	4.5" x 5.25"

#### FEATURES

- Hardened glass is heat-treated for strength.
- Meets or Exceeds: ANSI Z87-1, all current applicable Federal Specs., CSA Z94.3, CE and various International Standards.

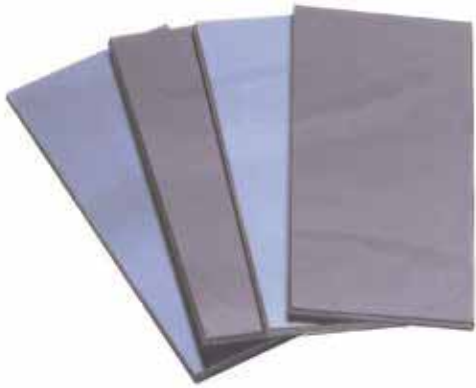

2" x 4-1/4"



4-1/2" x 5-1/4"

### Polycarbonate Cover / Safety Plates

#### Specifications

Part No.	Description	Size
1441-0048	Polycarbonate Cover/Safety Plate	2" x 4.25"
1423-4107	Polycarbonate Cover/Safety Plate, 3 pc./pk.	2" x 4.25"
1441-0050	Polycarbonate Cover/Safety Plate	4.5" x 5.25"

#### FEATURES

- Polycarbonate clear safety or cover plates, as components of welding goggles or helmets exceed the high velocity.
- Functions as either cover or safety plate
- Eliminates the accidental use of a cover plate in instances where a safety plate is necessary.



1441-0050



1441-0048



### Locking Pliers / Clamps

#### Specifications

Part No.	Description
1423-1432	Locking Pliers, 11"



### Steel Ground Clamps

#### Specifications

Part No.	Amperage Capacity	Jaw Opening	Cable Capacity	Length
1443-0026	300	Up to 2"	2-1	8"
1443-0027	500	Up to 2"	1/0-4/0	10"

#### FEATURES

- Large contact area assures positive grounding
- Zinc plated
- Large hex screw cable connection assures safe cable connection every time
- Pure copper braided shunts on 1443-0027 allows both jaws to carry welding current

1443-0026



1443-0027

### Cable Lugs

#### Specifications

Part No.	Cable Capacity	Amperage	Stud Hole	ID of Socket	Pack
1443-0003	4-6	100	21/64"	11/32"	2 pc./pk.
1443-0004	6-2	150	17/32"	1/2"	2 pc./pk.
1443-0005	1-2/0	200	17/32"	35/64"	2 pc./pk.

#### FEATURES

- Copper Alloy Lugs



1443-0003



1443-0004



1443-0005

### Chipping Hammer

#### Specifications

Part No.	Description
1423-0086	Cone and Chisel, 12", 14 oz.

#### FEATURES

- Hammer heads are hardened to precisely controlled temperatures for durability and strength
- Wide-blade design removes slag faster and adds to life of the tool



### Crimper™ Heavy Duty Lug/Splicer Crimping Tool

#### Specifications

Part No.	Jaw Opening	Cable Capacity
1423-1209	Up to 1"	6-4/0

#### FEATURES

- Durable spring loaded mechanism holds Terminal/Lug in place
- Delivers 1400-1800 lbs pull-out resistance (Terminal To Cable)



### Welper® MIG Pliers (8 tools in one!)

#### Specifications

Part No.	Description
1423-1428	Welper, MIG Pliers

#### FEATURES

- Designed for hammering, wire cutting, insulator bushing removal and installation and drawing out wire
- Perfect for removal and installation of contact tips and nozzles

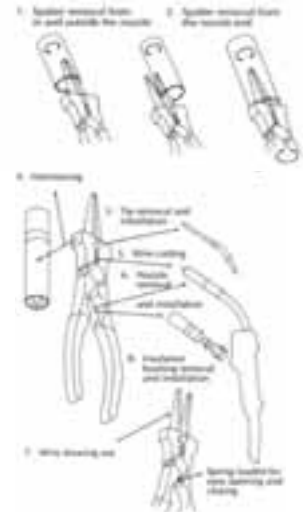

### Lightnin' Bug® Torch Lighter

#### Specifications

Part No.	Description
1423-1423	Lightnin' Bug, Torch Lighter

#### FEATURES

- Tested to 300,000 Strikes!
- Easy and accurate ignition insured by multi-spark discharge
- Zinc Plated body resists rust and corrosion



### Single Flint, Triple Flint and Flint Replacements

#### Specifications

Part No.	Description
1423-0026	Single Flint Spark Lighter
1423-0032	Flints for Single Flint Spark Lighter, 1 Holder/pk. (5 pcs.)
1423-0050	Triple Flint Spark Lighter
1423-0052	Flints for Triple Flint Spark Lighter, 2 per Pack



1423-0032



1423-0050

1423-0052

### Tip Cleaners

#### Specifications

Part No.	Description
1423-0016	Standard Tip Cleaner
0387-0487	King Size Tip Cleaner

#### APPLICATIONS

##### Standard

Set of 13 cleaners with file.  
Sizes #6 through #26 for cleaning Drill Size 77-49.

##### King Size

Set of 13 cleaners Extra Long with file.  
Sizes #6 through #26 for cleaning Drill Size 77-49.

#### Clean Hole

Gauge	Wire Dia.	Ridge Dia.	Diameter Inch	Drill Size
6	0.014	0.016	.018-.020	77-76
7	0.018	0.020	.021-.022	75-74
8	0.021	0.023	.024-.026	73-71
10	0.024	0.026	.028-.031	70-68
12	0.028	0.030	.032-.035	67-65
14	0.032	0.034	.036-.038	64-62
15	0.035	0.038	.039-.040	61-60
16	0.037	0.040	.041-.042	59-58
17	0.039	0.042	.043-.046	57
18	0.042	0.044	.046-.051	56
22	0.048	0.050	.052-.055	55-54
24	0.055	0.057	.060-.064	53-52
26	0.062	0.065	.067-.073	51-49



King Size



Standard

### Tip Drill Cleaner Kit (12 piece)

#### Specifications

Part No.	Description
1423-1408	Tip Drill Kit, 12 pc., Drill sizes: #52-74

#### FEATURES

- Cleans and Trues most Standard Orifices
- Contains most commonly used 12 drills (#57-74) in assorted sizes
- Complete with Built-in Chuck and Pocket Clip
- Drills are stored inside



Tip Drill Cleaner

### Soapstones & Soapstone Holders

#### Specifications

Part No.	Description
1423-0095	Flat Soapstone, 6 pcs./pk.
1423-0094	Round Soapstone, 5 pcs./pk.
1423-0097	Flat Soapstone Holder
1423-0096	Round Soapstone Holder



Flat Soapstone



Round Soapstone

### Oxy-Fuel Gas Hose Repair Kit

#### Specifications

Part No.	Description
1420-0296	DK-FP; Complete Dealer Kit*

#### FEATURES

- Streamlined, compact design allows welders to get into tight places
- Meets or Exceeds: ANSI Z87-1, CE and various International Standards



\*Includes: "A" and "B" size hose fittings with KI2B vise-grip type crimping tool. Contains nuts, nipples, couplers, splicers and ferrules for 1/4" and 3/16" I.D. hose.

### 4-Way Pick Set

#### Specifications

Part No.	Description
1423-1435	4-Way Pick Set

#### FEATURES

- Knurled 5" aluminum handle
- Four tempered steel picks 3" long – screw into handle





### Mag Tool™ Multi-Purpose Magnetic Holders

#### Specifications

Part No.	Size	Dimensions
1423-1425	Medium	4.7" x 3.4" x 0.56"
1423-1426	Large	6.3" x 4" x 0.63"

#### FEATURES

- Mag Tool will hold both sheet and tube at angles of 45°, 90° and 135° Clip

Magnet: Anisotropic Ferrite

\*\* In contact with ferrous objects of adequate thickness and smooth surface finish.

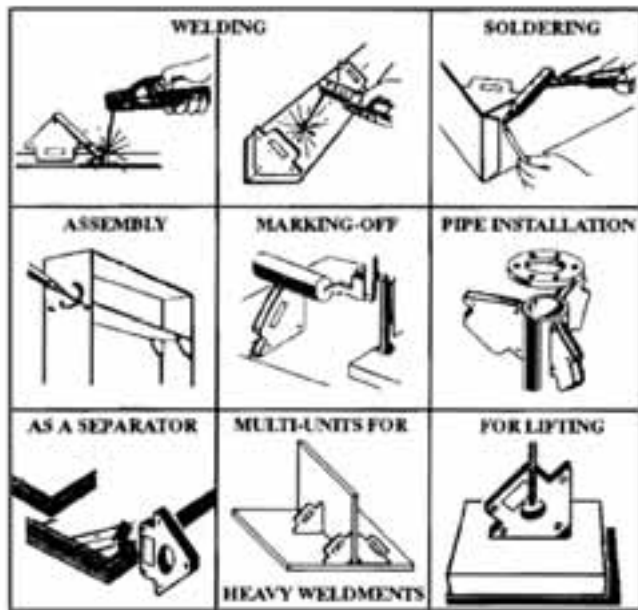

1423-1425

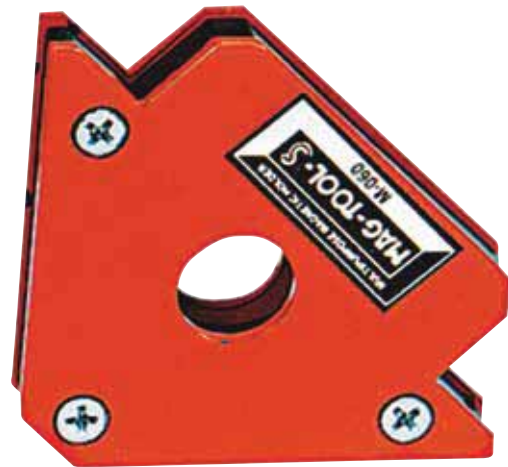

1423-1426

### Handyguard™, Welding Rod Storage Tube

#### Specifications

Part No.	Description
1421-0062	Handy Guard, Weld Rod Storage Tube

#### APPLICATIONS

Weld rod storage tubes provide great storage for all your welding electrodes, rods and filler metals. Chloride-free and features a threaded cap with long lasting neoprene seal to keep electrodes airtight-preventing them from being contaminated with atmospheric moisture.

- Holds up to 10 lbs of 12" or 14" Electrodes



### Scratch Brushes / Curved Long Handle Brushes

#### Specifications

Part No.	Wire	No. of Rows
1423-0087	Carbon Steel	3 x 19
1423-0082	Stainless Steel	3 x 19

Carbon Steel Hand Brushes can be used to prepare and clean weldments on mild steel and ferrous metals.  
Stainless Steel Hand Brushes can be used to prepare and clean weldments on stainless steel and aluminum.

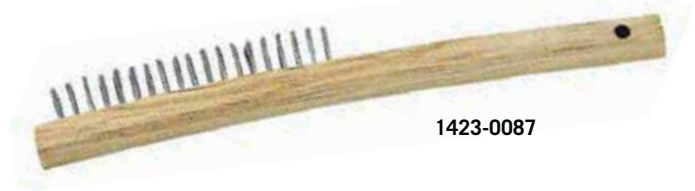

1423-0087

### Scratch Brushes / Shoe Handle Brushes

#### Specifications

Part No.	Wire	No. of Rows
1423-0083	Carbon Steel	4 x 16
1423-1442	Stainless Steel	4 x 16

Carbon Steel Hand Brushes can be used to prepare and clean weldments on mild steel and ferrous metals.  
Stainless Steel Hand Brushes can be used to prepare and clean weldments on stainless steel and aluminum.



1423-0083

### Scratch Brushes / Welders Toothbrush Style

#### Specifications

Part No.	Wire	No. of Rows
1423-0081	Stainless Steel Tinning	3 x 7
1423-0084	Brass	3 x 7
1423-1400	Brass	2 x 9

Stainless Steel Hand Brushes can be used to prepare and clean weldments on stainless steel and aluminum.  
Brass Hand Brushes can be used to prepare and clean solder joints on copper and brass.



1423-0081



1423-0084

### Flux Brushes

#### Specifications

Part No.	Trim Width	Trim Length	Total Length	Pack
1423-0093	1/2"	3/4"	5.75"	3 pc./pk.

Flux Brush can be used to apply liquid or paste fluxes.  
Do not use a single brush with multiple fluxes.  
Brass Hand Brushes can be used to prepare and clean solder joints on copper and brass.



### Parts Cleaning Brush

#### Specifications

Part No.	Handle	Length
1423-1402	Plastic	10.5"

Parts Cleaning Brush can be used in nearly any solvent.  
See page 49 for more brush information.



### End Brushes

#### Specifications

Part No.	Wheel Diameter	Type	Wire Size	Max. RPM
<b>CIRCULAR TYPE: 1/4" SHANK, CARBON STEEL WIRE</b>				
1423-2100	1.5"	Coarse	.014"	4,500
1423-2101	2"	Coarse	.014"	4,500
1423-2102	3"	Coarse	.014"	4,500
1423-2103	3"	Fine	.008"	4,500
<b>CRIMP TYPE: 1/4" SHANK, CARBON STEEL WIRE</b>				
1423-2104	3/4"	Coarse	.014"	4,500
1423-2117	1"	Coarse	.014"	4,500
<b>KNOT TYPE: 1/4" SHANK, CARBON STEEL WIRE</b>				
1423-2105	3/4"	-	.020"	20,000
1423-2118	1.5"	-	.020"	20,000



1423-2100



1423-2104



1423-2105

Firepower® small diameter wire brushes are designed for use in restricted or hard-to-reach areas. They are excellent for deburring, blending and cleaning of surfaces. Small diameter brushes are especially designed for use on portable air and electric tools. Applications include deburring, blending, removal of rust, cleaning. End brushes are great for cylinder heads, pistons and valve ports, rubber and plastic flash removal, removal of rust, paint scale, tool polishing, and weld cleaning.

### Safety First - Always Grind Safely!

#### Warning! Failure to Observe Safety Procedures May Result in Serious Injury:

Complies with Safety Standards of the Industrial Division of the American Brush Manufacturers Association and the American National Standards Institute ANSI B165.1-1985 "Safety Requirements for the Design, Care and Use of Power Driven Brushing Tools".

#### Always Wear Protective Equipment:

Impact resistant Safety Glasses or Goggles, Full Face Shield, Safety shoes, Arm Guards, Leather Gloves, Apron and other appropriate protective clothing must be worn by all operators and other employees working in the area of power brush operations. Always wear a respirator to avoid inhalation of dust particles.

#### Machine Guards Must Be Used:

Power brushes should be used only on machines that are equipped with Safety Guards, and they must be in place at all times.

#### Check Specifications On Mounting Brushes:

Check appropriate RPM before mounting any brush on a power tool. Arbor hole and spindle diameter should be a free fit. Spindle length should be sufficient to accept a full-nut mounting. Direction of spindle nut thread should be opposite to the direction of the spindle rotation so that the nut will tighten as the spindle revolves.

#### Always Inspect Before Use:

Carefully check all brushes in the original carton. Do Not Use if they are rusty or damaged. Brushes should be stored in the original cartons and should not be exposed to high humidity or other detrimental environmental conditions.

#### Always Observe Speed Limitations:

Observe all speed restrictions indicated on the brushes, containers, labels, or printed in pertinent literature. For reasons of safety, the "Max. RPM" Must Not be exceeded under any circumstances.

### Wire Cup Type

#### Specifications

Part No.	Cup Diameter	Wire Size	Max. RPM
<b>CRIMP TYPE: 1/4" SHANK, CARBON STEEL WIRE</b>			
1423-2106	1.5"	.014"	4,500
1423-2107	2.5"	.014"	4,500
1423-2108	2.5"	.008" (Fine)	4,500

<b>CRIMP TYPE: 5/8" - 11 NC THREADED ARBOR, CARBON STEEL WIRE</b>			
1423-2109	3"	.014"	12,500
1423-3158	4"	.014"	8,500

<b>KNOT TYPE: 3/8" - 24 NF THREADED ARBOR, CARBON STEEL WIRE</b>			
1423-3159	3"	.020"	12,500

<b>KNOT TYPE: 5/8" - 11 NC THREADED ARBOR, CARBON STEEL WIRE</b>			
1423-2110	3"	.020"	12,500
1423-2115	4"	.020"	8,500
1423-2116	6"	.020"	6,500

Firepower® wire cup brushes are designed for use on portable power tools. Made with high quality tempered wire, Firepower brushes provide fast cutting action for removal of light encrustation of scale, rust, paint or weld splatter. The relative high flexibility of Firepower wire cup brushes allows cleaning on irregular surfaces as well as flat surfaces.

**Cup Brushes with 1/4" Stem:** Small diameter cup brushes are designed for use in restricted or hard to reach areas. They are excellent for carbon cleaning, polishing, removal of scale, slag, rust and paint.

**Cup Brushes Crimped Wire:** Heavy-duty cup brushes with arbor adapters and threads to fit most grinders.

**Cup Brushes Stainless Steel Knotted Wire:** Heavy-duty cup brushes with arbor adapters and threads for most grinders. Stainless steel wire brushes are used to reduce discoloration and corrosion on stainless and aluminum alloys. Stainless steel wire brushes are highly corrosion resistant and should be used where contamination or after rust is a problem.



1423-2106



1423-2109



1423-3159



1423-2110



### Crimped and Knot Style

#### Specifications

Part No.	Wheel Diameter/Width	Wire Size	Arbor Hole	Max. RPM
<b>CIRCULAR TYPE: 1/4" SHANK, CARBON STEEL WIRE</b>				
1423-2327	4" dia. x 1/2" wide	.014"	5/8"-11 NC	8,000
1423-2121	6" dia. x 1/2" wide	.014"	5/8"-1/2"	6,000
1423-2122	6" dia. x 1" wide	.014"	5/8"-1/2"	6,000
1423-2123	8" dia. x 1.25" wide	.014"	5/8"-1/2"	4,500

#### CRIMP TYPE: 1/4" SHANK, CARBON STEEL WIRE

1423-2111	4" dia.	.020"	5/8"-11 NC	12,500
-----------	---------	-------	------------	--------

#### KNOT TYPE: 1/4" SHANK, CARBON STEEL WIRE

1423-2113	4" dia.	.020"	5/8"-11 NC	12,500
1423-2120	6" dia.	.020"	5/8"-1/2"	9,000

Firepower® knot-style wire wheel brushes are designed for tough jobs. Each individual knot contains an equal number of top quality high carbon tempered wires, which gives the wheel an exact balance and long-life. Firepower brushes can be furnished in either standard twist in carbon and stainless steel. Firepower brushes are well-suited for use in the welding and fabricating industries. They are used for surface preparation prior to welding and brazing and for removing weld scale and spatter after the welding operation.



1423-2121



1423-2113



1423-2111

### Arbor Reducing Adaptors

#### Specifications

Part No.	Description
1423-2124	Arbor Reducing Adaptor, 5/8"-11 to M10 x 1.25
1423-2125	Arbor Reducing Adaptor, 5/8"-11 to M10 x 1.5

#### APPLICATIONS

For both cup and wheel brushes - the fixed 5/8"-11 arbor hole of each brush can be adapted to M10 x 1.25, M10 x 1.50 and 3/8-24 NF by using arbor reducing adapter.



1423-2124

### Steel Rotary Files

#### Specifications

Part No.	Size	Shape
1423-2224	1/2" x 7/8"	Cylindrical
1423-2226	1/2" x 1/2"	Ball

#### FEATURES

- Rotary files offer perfect solutions for the welding jobs: Trimming welds, grinding smooth fillets & preparation for welds
- Repairs can be easily done because of a variety of shapes and sizes available
- All rotary files have a standard shank of 1/4" (6 mm)
- Note: use lower speeds when cutting harder ferrous materials and higher speeds for softer non-ferrous materials



1423-2224



1423-2226

### Mandrel Set

#### Specifications

Part No.	Size
1423-2185	1/4" Diameter Shank

#### FEATURES

- Made of high strength alloy steel
- Ideal for small diameter cut-off wheels with a thickness of 1/32" to 1/4"
- For cut-off wheels with an inner diameter of 1/4" or 3/8"

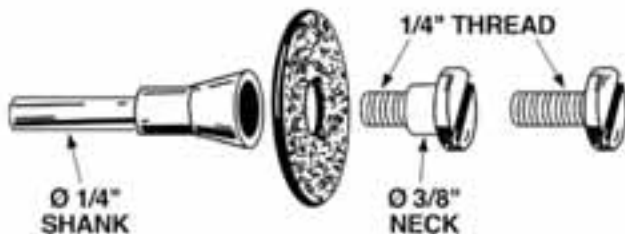

**CAUTION!** Rotary files are for use on electrical power drills only. They are not recommended for use on pneumatic or hydraulic tools.

### Steel Rotary Rasps

#### Specifications

Part No.	Size	Shape
1423-3177	1/2" x 7/8"	Cylindrical



### Mounting Points

#### Specifications

Part No.	Type & Shape	Size (Dia. x Length x Shank)	Max. RPM
1423-2202	A11	7/8" x 2.75" x 1/4"	19,000

#### FEATURES

- Offer maximum performance for grinding of ferrous and non-ferrous metals. For use with horizontal or straight shaft, die and pencil grinders on jobs where larger cones and plugs won't fit
- Excellent for medium to heavy duty applications in metal fabrication, foundries, steel mills. Used for grinding ferrous and non-ferrous metals
- Ideal for rapid stock removal on high alloy steel, castings and special steel



**CAUTION**  
Abrasive users and others in area must wear goggles or face shields over safety glasses

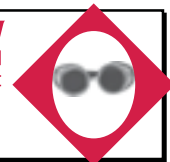

## Abrasive

Specification Example: A-36-S-B-2 FG

ABRASIVE	GRIT	GRADE	BOND TYPE	REINFORCEMENT
<b>A</b>	<b>36</b>	<b>S</b>	<b>B</b>	<b>2 FG</b>

Legend: Select one from each column.

ABRASIVE	GRIT	GRADE	BOND TYPE	REINFORCEMENT
A = Aluminum Oxide	Coarse: #16-24	Soft: H, I, J, K	B = Resinoid	1 FG = Inter-woven
	Medium: #30-60	Medium: L, M, N, O, P		
C = Silicon Carbide	Fine: #80-220	Hard: Q, R, S, T	V = Vitrified	2 FG = Double Reinforced

## Safety First - Always Grind Safely!

### Safety: Always DO the following:

1. **Always** handle and store abrasives in a careful manner.
2. **Always** visually inspect all abrasives before mounting for possible damage in transit, storage, or prior use.
3. **Always** "Ring Test" the wheel by tapping gently with a light metallic implement such as the handle of a screwdriver for light wheels, or Wooden or Plastic Mallet for heavier wheels. An undamaged wheel will give a clear tone.
4. **Always** make sure the operating speed established for the equipment does not exceed the wheel speed.
5. **Always** check mounting flanges for equal and correct diameter.
6. **Always** use mounting blotters when supplied with abrasives.
7. **Always** keep work rest properly adjusted within 1/8" (3 mm) of wheel face.
8. **Always** direct grinding sparks downward and away from the face and body.
9. **Always** wear protective equipment such as, impact resistant safety glasses or goggles, full face shield, safety shoes, arm guards, leather gloves and apron must be used for operator protection for all grinding operations. Always wear a respirator to avoid inhalation of dust particles.
10. **Always** use a safety guard covering at least one-half of the wheel diameter.
11. **Always** allow newly mounted wheels to run at operating speed, with the guard in place, for at least one minute before starting to grind.
12. **Always** observe all safety recommendations supplied by the Equipment Manufacturer.

### DO NOT attempt the following:

1. **Do Not** use a wheel that has been dropped.
2. **Do Not** use wheels that have been soaked in water
3. **Do Not** use wheels without guards for grinding or cutoff work.
4. **Do Not** force a wheel onto the spindle or alter the hole of size the wheel.
5. **Do Not** use a wheel that fits the arbor too loosely.
6. **Do Not** exceed maximum operation speed established for the wheel.
7. **Do Not** use dirty, nicked, warped or sprung mounting flanges.
8. **Do Not** tighten the mounting nut excessively.
9. **Do Not** grind on the side of the wheel unless the wheel is specifically designed for that purpose.
10. **Do Not** start machine unless the machine guard is in place.
11. **Do Not** jam work into the wheel. Let the wheel do the work.
12. **Do Not** apply excessive pressure.
13. **Do Not** stand directly in front of a grinding wheel whenever a grinder is started.
14. **Do Not** grind near flammable material.
15. **Do Not** grind or cut material for which the wheel is not designed.
16. **Do Not** flat grind. Minimum grinding angle is 15°.
17. **Do Not** use relieved or recessed flanges with threaded hole cup wheels, cone or plugs.
18. **Never** use a wheel or a disc that has been dropped, chipped, mishandled or appears defective.

### Cut-Off & Chop-Saw Abrasive Wheels, Type 1 (For Metal)

#### Specifications

Part No.	Size	Max. RPM	Grade
<b>TYPE 1, ABRASIVE CUT-OFF WHEELS</b>			
1423-3149	3" x 1/32" x 3/8"	25,000	A60T2FG
1423-3181	3" x 1/32" x 3/8" (5 pc./pk.)	25,000	A60T2FG
1423-3142	3" x 1/16" x 1/4"	25,000	A46T2FG
1423-3143	3" x 1/16" x 3/8"	25,000	A46T2FG
1423-3155	3" x 1/16" x 3/8" (5 pc./pk.)	25,000	A46T2FG
1423-2178	3" x 1/16" x 3/8" (10 pc./pk.)	25,000	A46T2FG
1423-3208	3" x 1/8" x 1/4"	25,000	A46T2FG
1423-3144	3" x 1/8" x 3/8"	25,000	A46T2FG
1423-2180	3" x 1/8" x 3/8" (5 pc./pk.)	25,000	A46T2FG
1423-3150	4" x 1/32" x 3/8"	18,000	A60T2FG
1423-3182	4" x 1/32" x 3/8" (5 pc./pk.)	18,000	A60T2FG
1423-3145	4" x 1/16" x 3/8"	18,000	A46T2FG
1423-3147	4" x 1/16" x 5/8"	18,000	A46T2FG
1423-3157	4" x 1/16" x 5/8" (5 pc./pk.)	18,000	A46T2FG
1423-3146	4" x 1/8" x 3/8"	18,000	A46T2FG
1423-3148	4.5" x 1/16" x 7/8"	13,300	A46T2FG
1423-3184	4.5" x 1/16" x 7/8" (5 pc./pk.)	13,300	A46T2FG
1423-3185	4.5" x 1/8" x 7/8"	13,300	A46T2FG
1423-3188	6" x .045" x 7/8"	10,200	A60T2FG
1423-3211	6" x 1/16" x 5/8"	10,200	A60T2FG
1423-2213	7" x 1/8" x 5/8" Diamond Hole	8,500	A36S 2FG

#### FOR STATIONARY CHOP-SAWS ONLY

1423-2305	10" x 1/8" x 5/8"	6,100	A36S 2FG
1423-3189	10" x 3/32" x 1"	6,100	A46S 1FG
1423-2197	12" x 3/32" x 1"	5,100	A46S 1FG
1423-2198	14" x 3/32" x 1"	4,400	A46S 1FG

#### FOR PORTABLE HIGH SPEED CHOP-SAWS

1423-3191	12" x 5/32" x 1"	6,300	A36S 2.5FG
1423-3193	14" x 5/32" x 1"	5,400	A36S 2.5FG



Firepower® Double Reinforced Cut-Off Wheels are designed for heavy duty cut-off jobs using circular saws, chop-saws and straight grinding machines. They ensure optimum effectiveness for dry applications on a broad

range of ferrous and non-ferrous metals, soft ceramics, masonry materials, reinforced plastic and fiber glass. Most Firepower cut-off wheels are double reinforced with two layers of fiber glass.

#### Use Tips for Firepower Cut-Off Wheels:

1. When using cut-off wheels, a soft pressure should be used for initial contact with the workpiece - cutting should be done with even constant pressure.
2. For stationary cut-off machinery, it is important to have good stability and steadiness to prevent vibration. Also, the motor should be powerful enough to keep the cutting time as short as possible to prevent burning or discoloring the material
3. Material being cut or ground should always be clamped or securely positioned, especially in cutting-off operations.
4. Proper machine speed is essential for maximum efficiency. Low speed causes "Jumping" of the disc, and can cause the circumference to wear unevenly.
5. Flat cut-off wheels can be brushed, if required.

#### Firepower® Cut-Off Wheel Safety and Cutting Procedures:

1. Cut-off wheels should never be stored on edges. They should be laid on a solid flat surface and away from excessive heat to prevent warpage.
2. Machines must have adequate power transmission and capacity, spindle speeds and proper guarding of the wheel. It is best to have extra power to insure good cutting efficiency. Check the speed of the machine spindle against the maximum speed specified for the wheel by the manufacturer. The maximum specified speed for the wheel should never be exceeded.
3. Flanges should be clean, straight and of the same diameter, so the wheel can turn true. For wheel diameters above 10" (250 mm) it is highly recommended that the flange be a least 1/3 the diameter of the wheel.
4. The bore size of the wheel is so constructed that the wheel should fit freely on the machine spindle without any slack. Never attempt to force a wheel on the spindle! Always use blotters, when supplied with the wheel. Be sure the flanges are tightened securely but not too tightly to avoid springing the flanges and change the pressure area.
5. Be sure work-piece is securely held down, including both sides of the cut, if practical. Cut-off wheels withstand a great deal of radial stress but not any side stress. Even reinforced wheels are not completely unbreakable. Side pressure must be avoided to insure straight cuts and avoid possible wheel breakage. The wheel must be brought into contact with the work without "Bumping" or impact. The wheel should cut freely without forcing and the speed of the wheel should not be reduced by the cutting operation.
6. Abrasive cutting generates a great deal of localized heat, which causes rapid expansion of the piece being cut. Wheels operated at speeds significantly below efficient speed or if fed through the cut to slowly will generate excessive heat. Result: rapid wheel wear, fraying around the edge of reinforced wheels and wheel breakage. Always use at the "efficient speed" as specified for the wheel by the manufacturer.



### Depressed Center Grinding Wheels, Type 27

#### Specifications

Part No.	Size	Max. RPM	Grade
<b>WITHOUT HUBS</b>			
1423-3151	4" x 1/8" x 5/8"	13,700	A36S
1423-2186	4" x 1/8" x 5/8" (5 pc./pk.)	13,700	A36S
1423-3152	4" x 1/4" x 5/8"	13,700	A24R
1423-2187	4" x 1/4" x 5/8" (5 pc./pk.)	13,700	A24R
1423-3186	4.5" x .045" x 7/8"	13,300	A36S
1423-3199	4.5" x 1/8" x 7/8"	13,300	A36S
1423-3153	4.5" x 1/4" x 7/8"	13,300	A36S
1423-2188	4.5" x 1/4" x 7/8" (5 pc./pk.)	13,300	A24R
1423-2189	5" x 1/4" x 7/8"	12,000	A24R
1423-2191	7" x 1/4" x 7/8"	8,500	A24R
<b>WITH HUBS</b>			
1423-3201	4.5" x 1/8" x 5/8"-11 NC	13,300	A24R
1423-2232	4.5" x 1/4" x 5/8"-11 NC	13,300	A24R
1423-3203	7" x 1/8" x 5/8"-11 NC	8,500	A24S
1423-2190	7" x 1/4" x 5/8"-11 NC	8,500	A24S
1423-2192	9" x 1/4" x 5/8"-11 NC	6,500	A24S



Firepower® depressed center wheels are fully reinforced with resin bonded aluminum oxide to ensure safety at high speed and to increase bonding and impact strength. Designed for use on air or electric powered right angle or vertical shaft grinders. Available with or without hubs.



#### Techniques/Tips for proper Firepower Grinding Wheels:

1. Use this method to achieve the desired aggressiveness of stock removal and quality finish - for fast material removal increase the grinding angle between the wheel and the workpiece. For blending and finishing decrease the grinding angle and apply light pressure in a fluid motion.
2. For maximum efficiency, Type 27 Depressed Center Wheels should be used with an approach angle of 30°-35° to the workpiece.
3. Material being cut or ground should always be clamped or securely positioned, especially in cutting-off operations.
4. Proper machine speed is essential for maximum efficiency. Low speed causes "Jumping" of the disc, and can cause the circumference to wear unevenly.
5. Only flat cut-off wheels can be brushed, not depressed center wheels. Only 7/8" arbors can be made to 5/8"-11.

### Bench Grinding Wheels, Type 1

#### Specifications

Part No.	Size	Grit
1423-2311	6" x 3/4"	36
1423-2310	6" x 3/4"	60
1423-2312	6" x 3/4"	80

#### FEATURES

- Wheels are individually precision balanced, trued and faced for smooth operation
- Each wheel is individually boxed so they stay clean and undamaged until use
- Designed for versatile off-hand grinding in deburring barstock after cutting and touching up, reconditioning and sharpening tools where precision grinding is not required
- Grinding is done on the wheel periphery only
- Aluminum oxide wheel grinds metal of high tensile strength, like steel and steel alloy



### Safety First - Always Grind Safely!

Always ensure grinding wheels and machines are in good working condition. Damaged or improperly used grinding wheels are dangerous. Machine guards are for protection - use them. Wear adequate personal protection. All Firepower® abrasives are manufactured under rigid quality conditions to ensure product strength and safety. However, approved guards and protective equipment,

such as, impact resistant safety glasses, full face shield, safety shoes, arm guards, leather gloves and apron must be used for operator protection for all grinding operations. Always wear a respirator to avoid inhalation of dust particles. For information on product safety, please ask us for ANSI B7.1 "Safety Requirements for the use, Care and Protection of Abrasive Wheels".

#### Techniques/Tips for proper Firepower Grinding Wheels:

1. Use this method to achieve the desired aggressiveness of stock removal and quality finish - for fast material removal increase the grinding angle between the wheel and the workpiece. For blending and finishing decrease the grinding angle and apply light pressure in a fluid motion.
2. For maximum efficiency, Type 27 Depressed Center Wheels should be used with an approach angle of 30°-35° to the workpiece.
3. Material being cut or ground should always be clamped or securely positioned, especially in cutting-off operations.
4. Proper machine speed is essential for maximum efficiency. Low speed causes "Jumping" of the disc, and can cause the circumference to wear unevenly.
5. Only flat cut-off wheels can be brushed, not depressed center wheels. Only 7/8" arbors can be made to 5/8"-11.

### Flap Discs Zirconia, Type 29

#### Specifications

Part No.	Grit
<b>4.5" X 7/8" (WITHOUT HUB) MAX RPM: 13,300</b>	
1423-3162	ZA 36
1423-3163	ZA 60
1423-3164	ZA 80
<b>4.5" X 5/8"-11 NC (WITH HUB) MAX RPM: 13,300</b>	
1423-2220	ZA 36
1423-2221	ZA 60

Firepower® flap discs durability over the conventional fibre disc results in reduction of both labor and material costs. They are designed to wear away evenly and present a constantly fresh working surface.

- Cut and finish at the same time with consistent finish - for coarse and intermediate grinding and machining of welds, deburring, rust removal, snagging, removal of paint, etc. This means fewer change-overs
- Suitable for almost all materials: ferrous and non-ferrous metals, wood, leather, glass, marble and plastics
- No loading-up, as new sharp abrasive particles are constantly exposed
- No backing pad required - comes with fiberglass backing plate with higher RPM rating than resin fiber discs
- Firepower flap discs have the ideal operating angle of 10°. This allows for maximum use of the laminates and guarantees optimum stock removal produced by a continuously free cutting abrasive
- Excessive pressure leads to a higher wheel-wear, without increasing performance



1423-3162

#### Recommendation:

- We recommend using the following grit sizes to attain a maximum stock removal rate
  - Grit 36\*: For all alloyed and low-alloyed steels
  - Grits 60 & 80\*: For high alloyed steel, stainless steel, high-temperature and heat treatable steel and high tensile, non-ferrous metals
- \* **A coarser grit offers the advantage of a higher stock removal rate and service life**

#### Safety First - Always Grind Safely!

To avoid injury always wear complete body protection at all times: Impact-resistant protective glasses, full face shield, safety shield, safety shoes, arm guards, leather gloves and apron for all grinding operations. Always wear

a respirator to avoid inhalation of dust particles. Persons entering an area where grinding is taking place, must always wear adequate and approved face and body protection.

#### For Abrasive Disc Grinding:

1. Never use larger diameter disc than specified by the manufacturer
2. Never exceed maximum RPM
3. Always check the pad for concentricity.
4. Always check for snug fit and full-thread contact.
5. Always use the grinders safety pad.
6. Always check the spindle for wobble.
7. Always check the disc retainer nut for thread wear.

### Resin Fiber Sanding Discs and Hand Pads

#### Specifications

Part No.	Grit
<b>5" X 7/8" (3 PC./PACK) MAX RPM: 11,000</b>	
1423-2164	A.C 24
1423-2165	A.C 36
1423-2166	A.C 50

<b>7" X 7/8" (3 PC./PACK) MAX RPM: 7,600</b>	
1423-2171	A.C 24
1423-2172	A.C 36
1423-2173	A.C 50

Firepower® resin fibre discs have the best combination of the highest quality aluminum oxide grains and heavy-duty vulcanized fibre-cloth backing bonded with strong, heat resistant resin.

- Excellent for removing rust, oxides and surface imperfections
- Maximum performance on portable right angle grinders
- Firepower resin fibre discs should be mounted on a rubber backing pad, for optimum performance



### Safety First - Always Grind Safely!

To avoid injury always wear complete body protection at all times: Impact-resistant protective glasses, full face shield, safety shield, safety shoes, arm guards, leather gloves and apron for all grinding operations. Always wear

a respirator to avoid inhalation of dust particles. Persons entering an area where grinding is taking place, must always wear adequate and approved face and body protection.

#### For Abrasive Disc Grinding:

1. Never grind without a proper back-up pad
2. Never exceed maximum RPM
3. Never use larger diameter disc than specified by the manufacturer
4. Never use back pad without first inspecting it for signs of irregularities such as fractures, excessive wear, nicks, cuts at the edges or the center hole.
5. Always check the pad for concentricity. Always check the grinder spindle for wobble. Always check the disc retainer nut for thread wear. Install the pad on the tool securely. Check for snug fit and full-thread contact.
6. Direct grinding sparks downward and away from the face and body. Do Not Grind near any flammable material.
7. Never use another grinding disc as a back-up pad.
8. Never exceed maximum RPM.
9. Always use the grinders safety pad.
10. Operate grinder with disc and pad inclined approximately 5°-15° from the work surface. Grind depressions, moulding, lips and heavy welds with the grinder moving away from the work area and not into it. Avoid grinding near the edge, corner or projections that can snag the edge of the pad or disc.
11. Always observe all safety recommendations supplied by the equipment manufacturer.



### Quick Change and Surface Conditioning Discs, Type III

#### Specifications

Part No.	Grit/Color	Type	Pcs./pk.
1423-2140	Brown	Coarse	10
1423-2141	Maroon	Medium	10

#### SURFACE CONDITION DISCS, 3"

1423-2143		Ø 3" x 1/4" Shank	
-----------	--	-------------------	--

- Provide low vibration, less tool down time, and longer disc life
- Designed for quick disc and grit changes
- These time saving discs are quickly and firmly mounted on a special reusable 1/4" mandrel
- Surface conditioning discs provide superior performance for: Scratch removal, Removing flash, rust and oxidation, light deburring, blending welds, blending and conditioning metal surfaces and removing heat discoloration
- Maximum RPM: 5,000

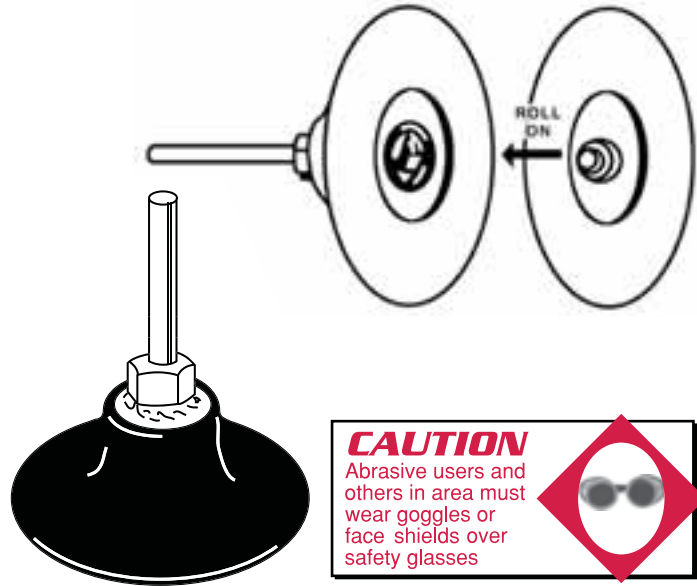

### Mounted Flap Wheels

#### Specifications

Part No.	Wheel Dimensions	Grit	Max. RPM
1423-2160	1" x 1" x 1/4"	60	25,000
1423-2161	1" x 1" x 1/4"	80	25,000
1423-2157	1.5" x 1/2" x 1/4"	60	25,000
1423-2158	1.5" x 1/2" x 1/4"	80	25,000
1423-2154	2" x 1" x 1/4"	60	20,000
1423-2155	2" x 1" x 1/4"	80	20,000
1423-2151	3" x 1" x 1/4"	60	18,000
1423-2152	3" x 1" x 1/4"	80	18,000

Firepower® flap wheels are constructed of hundreds of resin bonded cloth abrasive sheets firmly attached to a balanced core. During use, each flexible sheet adapts quickly to the contours of the workpiece - continuously exposing fresh, sharp grit for extended product life. The controllable aggressiveness, working speed, and low cost of the wheels make them superior to wire brush, grit-impregnated plastic, fibrous and setup wheels in a wide range of applications.



#### Tips for Firepower Abrasive Flap Wheels:

1. Make sure flap wheel is run in correct direction of rotation. For automatic in-feeding of workpiece, the direction of flap wheel rotation should be contrary to the feed direction.
2. For a given finish, choose a grit one or two sizes coarser compared to abrasive belts.
3. Coarse grit sizes used at high speeds work finer. Fine grit sizes used at lower speeds work coarser.
4. Grinding oil or grease may be used for improved finish and the flap wheel life.
5. Use light pressure at low speeds, added pressure at high speeds. Do Not use excessive pressure or allow the flaps to bend back too far. If more stock removal is necessary, choose a coarser grit.
6. Abrasive flap wheels can be shaped to fit contours and other configurations by using a file, abrasive stone, or other cutting tool to cut the mop face. Always use proper safety equipment.
7. Make sure that mounting plates are of the proper size and are correctly fitted when used. Never over tighten fastening nuts or hub damage may result. Always use proper machine guards.



# Gondola Merchandiser Plan-O-Gram for Welding, Cutting, Brazing and Safety Products

## Firepower Innovative Plan-O-Gram Easy Select 4 ft Accessories Header

Welding & Cutting Info Center

MIG CONSUMABLE CHARTS				MIG WIRE AMPERAGE RANGE				ALUMINUM TIG WELDING PARAMETERS				STEEL & STAINLESS STEEL TIG WELDING PARAMETERS				STICK CONSUMABLE CHARTS				ELECTRODE AMPERAGE CHART				
MIG WELDING WIRE SELECTION				MIG WIRE AMPERAGE RANGE				ALUMINUM TIG WELDING PARAMETERS				STEEL & STAINLESS STEEL TIG WELDING PARAMETERS				STICK WELDING WIRE SELECTION				ELECTRODE AMPERAGE CHART				
Wire	Shielding Gas	Process	Application	Wire	Current	Speed	Electrode	Current	Speed	Electrode	Current	Speed	Electrode	Wire	Shielding Gas	Process	Application	Wire	Current	Speed	Electrode	Current	Speed	Electrode

## Firepower Innovative Plan-O-Gram Easy Select 4 ft Equipment Header

Welding & Cutting Info Center

STICK		STICK + DC TIG		AC/DC TIG + STICK		MIG				MIG + STICK + DC TIG				MST 3-IN-1		PLASMA CUTTING		OXYFUEL	
Wire	Shielding Gas	Wire	Shielding Gas	Wire	Shielding Gas	Wire	Shielding Gas	Wire	Shielding Gas	Wire	Shielding Gas	Wire	Shielding Gas	Wire	Shielding Gas	Wire	Shielding Gas	Wire	Shielding Gas

Eight foot (96")  
Accessory Mix:

DISPLAYS  
**177**  
ITEMS



Four foot (48")  
Accessory  
Mix:

DISPLAYS  
**102**  
ITEMS



Suggested  
Equipment:

5-PIECE  
EQUIPMENT



Check out the collection of abrasives, grinding and sanding we offer.