

FILL-RITE®

PORTABLE
SERIES

RD



THE PERFECT PUMP FOR PLAY (OR WORK IF YOU MUST)

THE ONLY PORTABLE
DC PUMP UL LISTED FOR
USE WITH GASOLINE
AND OTHER FLAMMABLE LIQUIDS

PROUDLY
 Made in
USA

EC-FRIENDLY

THIS PUMP DOES THE
HEAVY LIFTING
NO SPILLS!



DITCH THE CAN

Gasoline, Diesel, Handheld, Mounted... It goes where you go.



Configurable flanges

Position the inlet and outlet hoses to fit your needs. Remove two bolts, rotate the flange and you're done. Isn't versatility fun?



Aluminum construction

Pump weighs only 7 lbs.

Multiple mounting options

Bung mount, foot mount or handheld; versatile enough to fit your application.

Quick connect power cord

Simple, quick and safe connection to your power source, no electrician required!

Available Models

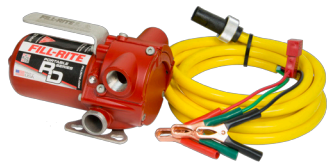

RD812NN

Pump Only
Includes

- 10' Quick connect power cord with alligator clips



RD812NH

Pump with Hose and Nozzle
Includes

- Manual nozzle
- 8' Discharge hose
- 6' Suction hose
- 10' Quick connect power cord with alligator clips



RD812NP - Bung Mount Option

Pump with Hose and Nozzle
Includes

- Manual nozzle
- 8' Discharge hose
- 23"-41" Telescoping suction tube
- Nozzle boot
- Bung tank mount adapter
- 10' Quick connect power cord with alligator clips

Features

- Up to 8 GPM (30 LPM)
- Gasoline, diesel, biodiesel (up to B20), kerosene and E15
- Aluminum construction
- 3/4" inlet/outlet
- Low profile
- Thermally protected
- Self-priming
- 30-Minute duty cycle
- Smooth in-line switch

FILL-RITE®

The Most Trusted Name in Pumps and Meters

RD8 Series Technical Specifications

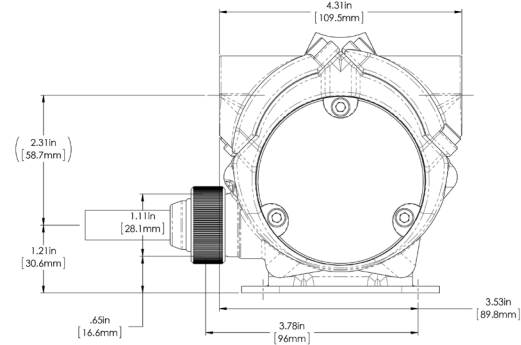
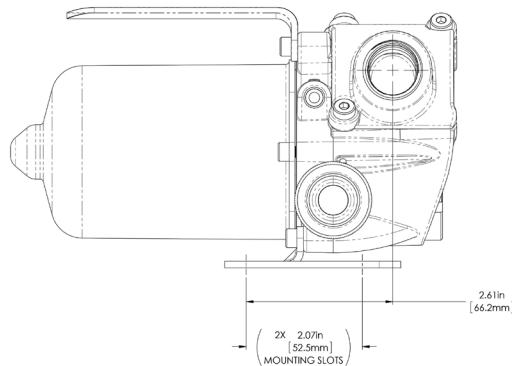
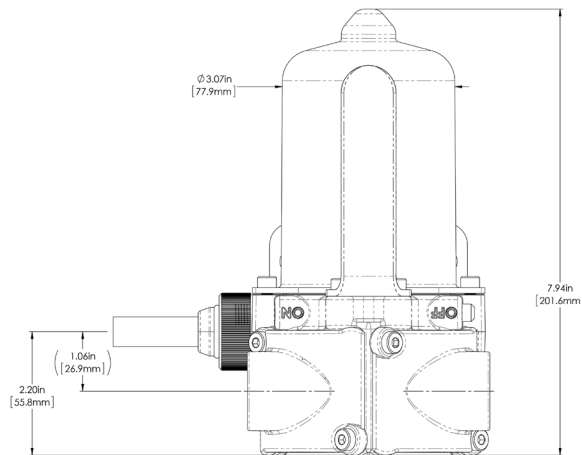

Pump		Motor	
Type - Rotary, Diaphragm, Gear, Vane	Rotary Hinged Vane	Power - AC 115,230, 115/230 VAC	N/A
Flow Rate in supplied configuration	Up to 8 GPM / 30 LPM	HZ 50,60,50/60	N/A
Flow Rate open flow - no hose or nozzle-	Up to 10 GPM / 38 LPM	Power - DC 12, 24, 12/24	12 VDC
By-Pass Pressure Rating (PSI) - Max	16 PSI	HP (Horsepower) Rating	1/6 HP
Dry Vac (in Hg)	5	Power Cord Length (feet)	10'
Head - Max (Ft.)	37	Power Cord Gauge (AWG)	12 AWG
Anti-Siphon Valve	None	DC Power Cord Connectors	NONE
Inlet - Size / Thread	3/4" NPT / 3/4" BSPP	Amps (FLA)	14
Outlet - Size / Thread	3/4" NPT / 3/4" BSPP	RPM	3600
Mount	2" Bung NPT / BSPP	Duty Cycle	30 min. on / 30 min. off
Material - Pump Housing	Aluminum	Thermal Protection Switch	Yes
Material - Wetted Material	BUNA-N + HNBR	Circuit Protection Fuse	None
Rotor Material	Nylon	Certification	UL, cUL Motor, ATEX, CE, ANZEx
Rotor Vane Material	Acetal		
Compatible Fluids	Diesel, Gasoline, BioDiesel up to B20, E15, Kerosene, Methanol (to 15%)		
Strainer Mesh Size	20 X 20		



Excellence at work. Excellence in life.

1200 SERIES PERFORMANCE CURVE

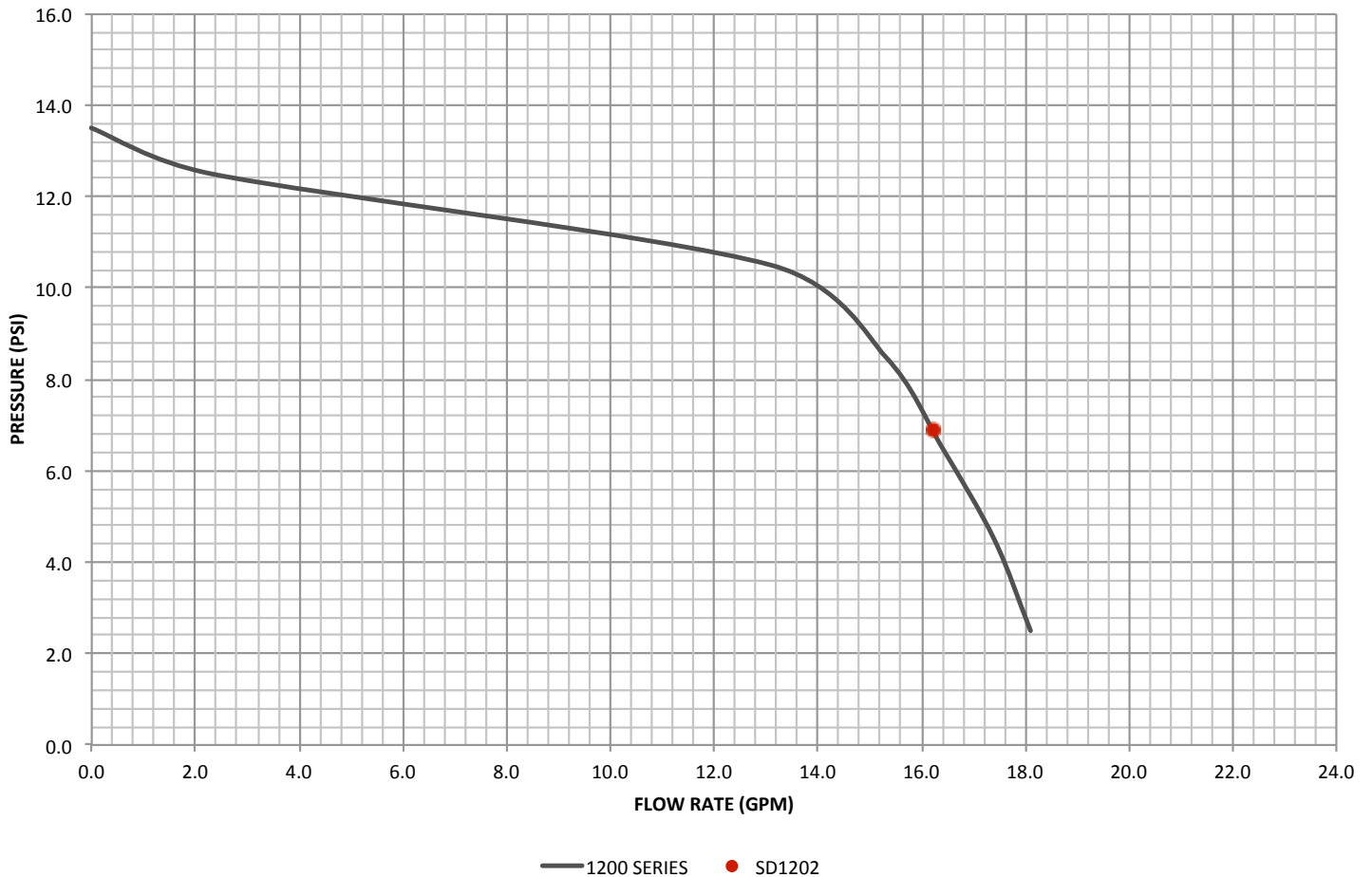

SERVICE KIT INFORMATION

Kit	Description	Parts
KIT812PC	Power Cable Kit	Quick Connect Power Cable Assembly
KIT812RG	Rotor & Vane Kit	Rotor & Vanes, Rotor Cover, Inlet Screen, Flange O-rings, Rotor Cover O-Ring, Flange Fasteners
KIT812FL	Single Flange Kit	Flange, Inlet Screen, Flange O-Ring, Flange Fasteners
KIT812SL	Seal Kit	Inlet Screen, Flange O-rings, Rotor Cover O-Ring, Flange Fasteners, Rotor Cover Fasteners
KIT812NH	Hose Kit	3/4" x 6' Suction Hose, 3/4" x 8' Discharge Hose, PTFE Tape
KIT812NP	Bung Mount Kit	Suction Tube, Bung Adapter, Nipple, Nozzle Boot, Nozzle Boot Fasteners, PTFE Tape

Accessories

Suction pipe material	N/A
Suction pipe length - extended/notextended	None
Nozzle - size	N/A***
Nozzle - Manual / Automatic	N/A***
Hose liquid materials compatibility	Oil, Gasoline, Diesel***
Hose diameter	3/4"***
Hose length	N/A***
Hose static wire (Y/N)	N/A***

Logistics

UPC	0-89404-17578-1***
Length	15.5"
Width	10"
Height	6.5"