

FILL-RITE®

Owner's Operation and Safety Manual
Portable DC Powered Fuel Transfer Pump

**PORTABLE
SERIES**
RD



 **Tuthill**

PROUDLY
 **Made in
USA**

Original Instructions

Table of Contents

Safety Information	3
Installation	3
Bung Mount Configuration.....	4
Mounting Foot and Nozzle Boot Installation.....	4
Suction Hose Configuration.....	5
Fueling Safety.....	6
Flange Configuration	5
DC Power Connection	6
Power Switch	7
Operational Safety.....	7
Troubleshooting.....	8
Cleaning the Inlet Screen.....	9
Accessories	9
Technical Information	10
Motor Tag Information.....	10
Kits and Parts	11
Safety Testing Certifications	11

Thank You!

Thank you for your purchase of the RD series portable pump! Your Fill-Rite® product comes with over 80 years of pump manufacturing experience behind it, providing you the value that comes with superior performance, user friendly design, outstanding durability, and solid, simple engineering. Experience that gives you peace of mind.

Tuthill. Pump Your Heart Into It!

About This Manual

From initial concept and design through its final production, your Fill-Rite® pump is built to give you years of trouble-free use. To ensure it provides that service, and to avoid injury or death, it is critical that you read this entire manual prior to attempting to install or operate your new pump. Become familiar with the terms and diagrams, and pay close attention to the highlighted areas with the following labels:



DANGER! Emphasizes an area in which personal injury or even death **will** result from failure to follow instructions properly. Mechanical damage may also occur.



WARNING! Emphasizes an area in which personal injury or even death **may** result from failure to follow instructions properly. Mechanical damage may also occur.



CAUTION! Failure to observe a “Caution” may cause damage to the equipment.



IMPORTANT! These boxes contain information that illustrates a point that may save time, or be key to proper operation, or clarifies a step.

Safety Information



DANGER! Electrical wiring should be performed with extreme caution and in compliance with local, state, and national electrical code NEC/ANSI/NFPA 70, NFPA 30, and NFPA 30A, as appropriate for the intended use of the pump. Threaded rigid conduit, sealed fittings, and conductor seal should be used where applicable. The pump must be properly grounded. If installing in deviation of this manual, a licensed electrician must perform the installation. Improper installation or use of this product will result in serious bodily injury, or death!



DANGER! To ensure safe and proper operation of your equipment, it is critical to read and adhere to all of the following safety warnings and precautions. Failure to follow instructions below, improper installation, or use of this product, will cause serious bodily injury or death!

- **NEVER** smoke near the pump, or use the pump near open flames when pumping a flammable liquid! Fire can result!
- This product shall not be used to transfer fluids into any type of aircraft due to spark / static discharge possibility. Spark / static discharge will cause explosions.



DANGER! To minimize static electricity build up and possible explosion, use only static wire conductive hose when pumping flammable fluids, and keep the fill nozzle in contact with the container being filled during the filling process. Spark / static discharge will cause explosions.



WARNING! Threaded pipe joints and connections should be sealed with the appropriate sealant or sealant tape to minimize the possibility of leaks. Leaking fuel may cause the potential for fire and explosion.



CAUTION! The pump motor is equipped with thermal overload protection; if overheated, the motor will shut off to prevent damage to the windings. If this happens, you must turn off the pump power to reset this safety feature, and turn the pump back on when it has cooled to continue use. The pump will not restart until properly cooled.



CAUTION! This product is not suited for use with fluids intended for human consumption or fluids containing water. Materials of construction are not food grade. The pump is water tolerant, however, extended use with water will shorten the life of the vanes, and can cause swelling of the rotor. Flush / drain the pump after pumping water to be certain water does not stand in the pump body to prevent premature wear. Flush with a petroleum product (gasoline, diesel, light oil, etc) to eradicate residual water.



IMPORTANT! A Fill-Rite Filter should be used on the pump outlet to ensure no foreign material is transferred to the fuel tank. Foreign material can damage the equipment being fueled.

Installation

The Fill-Rite RD Series pump is designed to be portable for your convenience and safety. It features a unique hinged vane design that eliminates the need for a bypass valve. Because of its unique nature, the RD series pumps can be installed / used in several configurations. Read each configuration prior to beginning installation.



WARNING! The RD Series pump is designed primarily for portable applications, using skid tanks, drums, barrels, and other portable fuel containers to supply fuel. It is paramount to anchor the supply tank or drum to which the pump is connected to ensure no movement occurs in transit or while fueling. Failure to secure the tank or drum can cause unexpected and uncontrolled movement, resulting in damage, injury, death, and potential fire or explosion.



IMPORTANT! Do not use check valves or foot valves; valves reduce rate of flow and performance of the pump.

Bung Mount Configuration



WARNING! Threaded pipe joints and connections should be sealed with the appropriate sealant or sealant tape to minimize the possibility of leaks. Leaks create the potential for fire or explosion.

The RD series pump mounts to the bung by way of the bung adapter suction tube. The suction tube threads into the bung adapter, and must be adjusted to a length that positions it within 3" from the bottom of the tank. The tank or drum must be vented. Be certain power is disconnected before proceeding.

1. Change outlet configuration (A) for horizontal discharge (optional). See Page 6 for instructions.
2. Screw nipple (B) into pump inlet and tighten liquid tight.
3. Screw other end of nipple into bung adapter (C) and tighten liquid tight.
4. Screw threaded end (D) of the adjustable suction tube into the bottom of the bung adapter.
5. Extend suction pipe into tank or barrel opening to within 3" of bottom of tank or barrel. **Do not** rest suction pipe on bottom.
6. Thread bung adapter into bung and tighten.
7. Install discharge hose with a nozzle or valve at the end that can be shut off tightly to prevent siphoning when the pump is not in use.
8. Attach nozzle boot (E) to pump foot (optional).

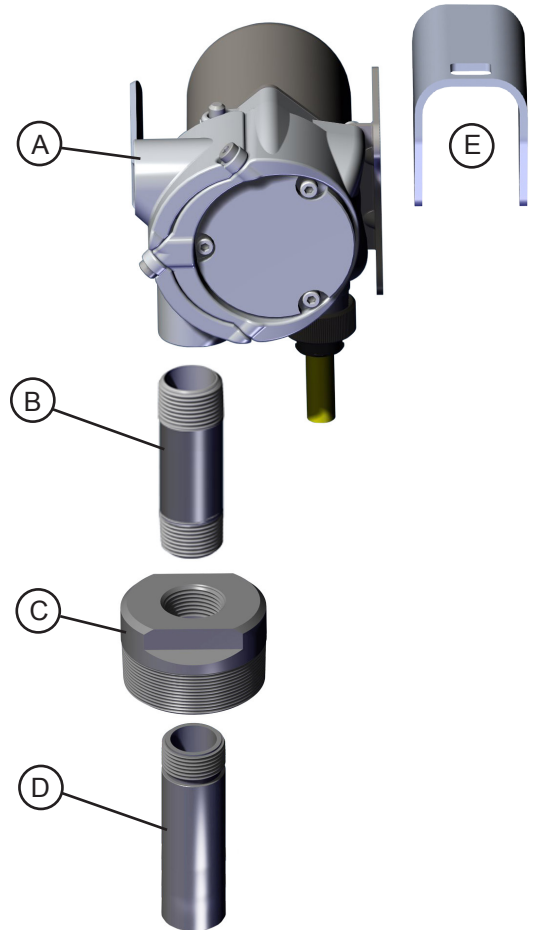

Mounting Foot and Nozzle Boot Installation

The mounting foot is bolted to the bottom of the pump using the two supplied socket head cap screws. Mount the foot with the longest side facing the front of the pump as illustrated. Torque to 50 in/lbs. with 4 mm hex key.

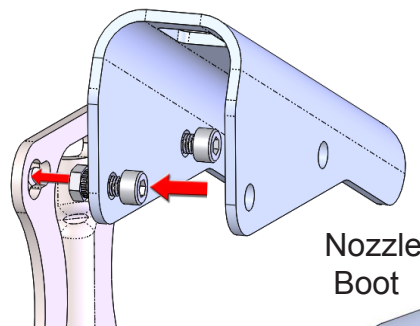
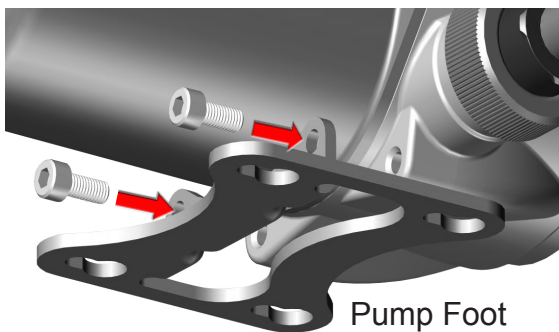

In bung mount applications a nozzle boot can be attached to the pump mounting foot for nozzle storage.

- Insert the two - 5 mm socket head cap screws through the nozzle boot.
- Thread the clinch nuts partially onto the 4mm socket head cap screws.
- Insert the nut / screw assembly through slotted openings in the pump foot.
- Slide the assembly into the narrow end of the slots.
- Use a 4mm hex head key to tighten the nozzle boot into place.

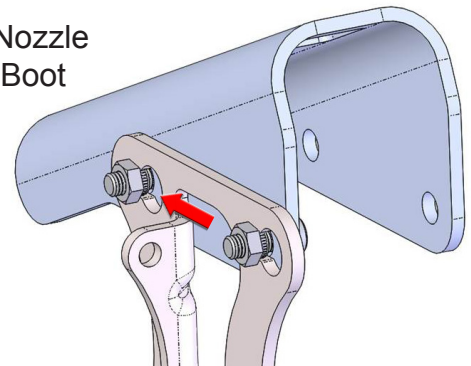

Suction Hose Configuration



WARNING! Threaded pipe joints and connections should be sealed with the appropriate sealant or sealant tape to minimize the possibility of leaks. Leaks create the potential for fire or explosion.

1. Select chemically compatible inlet and outlet hoses that contain a static discharge wire, are for use with flammable liquids, and are rated to at least 50 psi.
2. Reconfigure inlet and outlet flanges if necessary (optional). Instructions below.
3. Use a conductive nozzle or valve at the end of the discharge hose that can be shut off tightly to prevent accidental siphoning when the pump is not in use.
4. **NOTE:** If pumping from a metal container, the metal end of suction hose **MUST** be in contact with the metal container for electrical continuity.

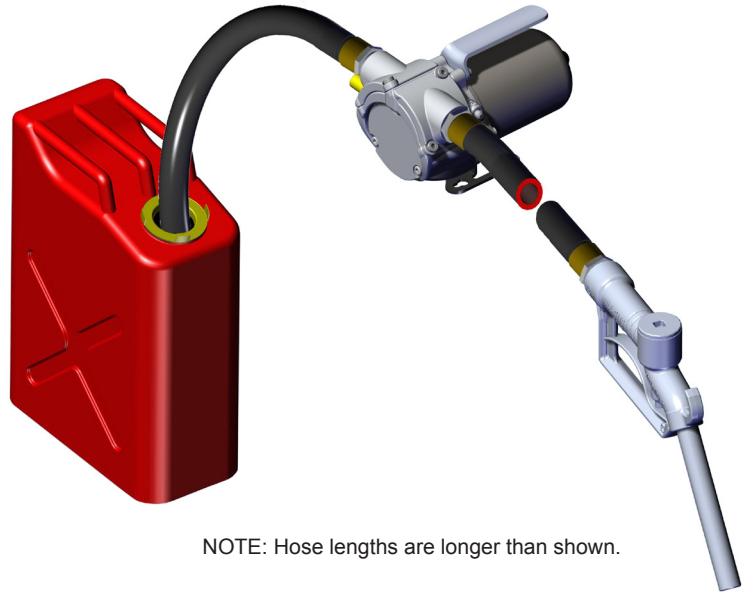

NOTE: Hose lengths are longer than shown.

Fueling Safety



DANGER! Fumes accumulated while fueling create an Explosive Atmosphere. It is **CRITICAL** that all possible sources of ignition be removed to a safe distance or extinguished. Sources of ignition would include (but not be limited to) open flames, cigarettes, static discharge, or electrical connections that can create a spark. Explosion, fire, and severe injury or death will occur if the explosive vapors are ignited.

Fumes accumulated while fueling create an Explosive Atmosphere around the tank that is being filled. To avoid possible explosion of accumulated vapors, it is critical to keep possible sources of spark / ignition at safe distances from the fuel vapors.

The accompanying diagram shows minimum safe distances for safe fueling. 10' is the minimum safe distance between:

- Power source and fuel supply.
- Power source and tank being filled.
- Power source and pump.

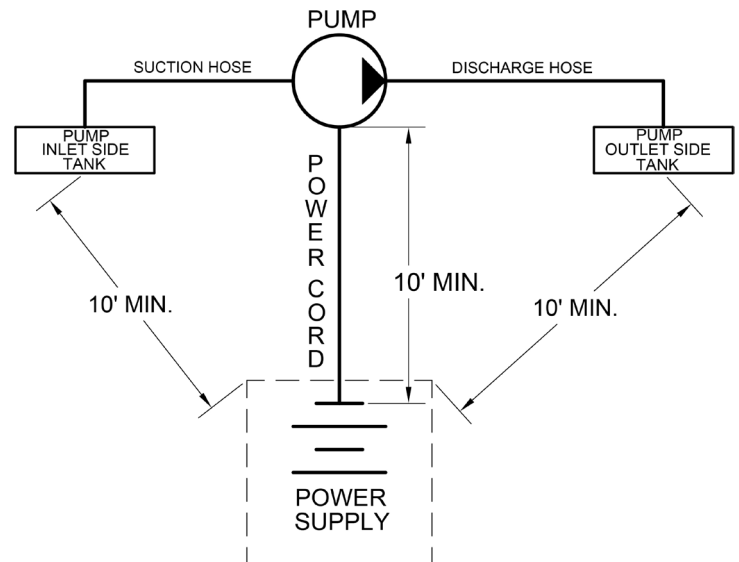

<p>WARNING</p> <ul style="list-style-type: none"> • STATIC ELECTRIC SPARK EXPLOSION HAZARD • NEVER fill portable containers that are in or on vehicles 		<ul style="list-style-type: none"> • ALWAYS PLACE CONTAINERS ON GROUND • Keep nozzle in contact with container while filling. 	<p>A static electric spark can occur when filling portable containers sitting on truck bed liners, or on any vehicle's carpeting or floor matting.</p> <p>This spark will explosively ignite a gasoline vapor fire and cause SERIOUS INJURY or DEATH</p>
---	--	---	--

Flange Configuration

WARNING! Be certain seals and screen are properly positioned and clean any time the flanges are reconfigured. Improperly installed or dirty seals or screens could cause leaks and the potential for fire or explosion

CAUTION! Always be certain the power switch is accessible after reconfiguring the inlet and outlet ports.

The inlet and outlet flanges of your RD series pump can be configured vertically, horizontally, or a combination of both. To change the position of a flange:

1. Remove the two socket head cap bolts holding the flange in position.
2. Remove the flange; examine the sealing surfaces to be certain they are clean and will seal properly.
3. Position the seal and screen, and place the flange in the desired position.
4. Use the two socket head cap bolts to reattach the flange firmly to the pump housing. Torque to 50 inch lbs. with a 4 mm hex key.

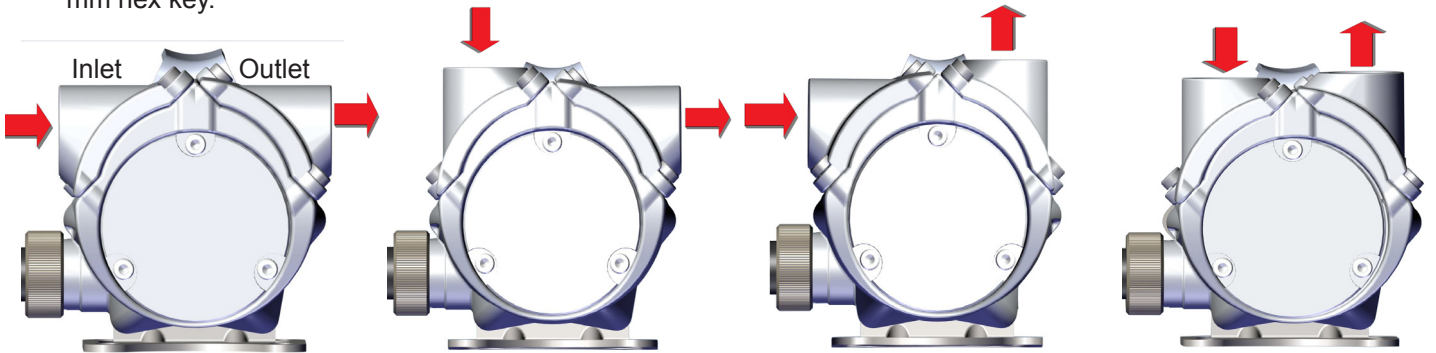

DC Power Connection

DANGER! Be certain the power switch is “OFF” prior to connecting the battery clamps / power cables to the power source or installing the cable into the pump to prevent unexpected starting of the motor. Unexpected motor start can cause unintended discharge of fuel, creating an explosion and fire hazard.

Inspect power cable before each use! Damage to the outer jacket of the cable that exposes wiring requires replacement of the power cable.

Install power cable by aligning flat on plug with front of pump. Insert the plug into the pump housing as shown. Lock into place using the threaded collar (A). **HAND TIGHTEN ONLY!** The power cable terminates in green, black, and red clamps. All three clamps must be used.

1. The green (ground) clamp should be connected first. Connect the green clamp to the vehicle chassis or earth ground. **DO NOT** connect the green clamp to the negative power source post.
2. Next, connect the black (negative) clamp to the negative post of the DC power source.
3. Connect the red (positive) clamp to the positive post last.

Clamps should be disconnected in reverse order.

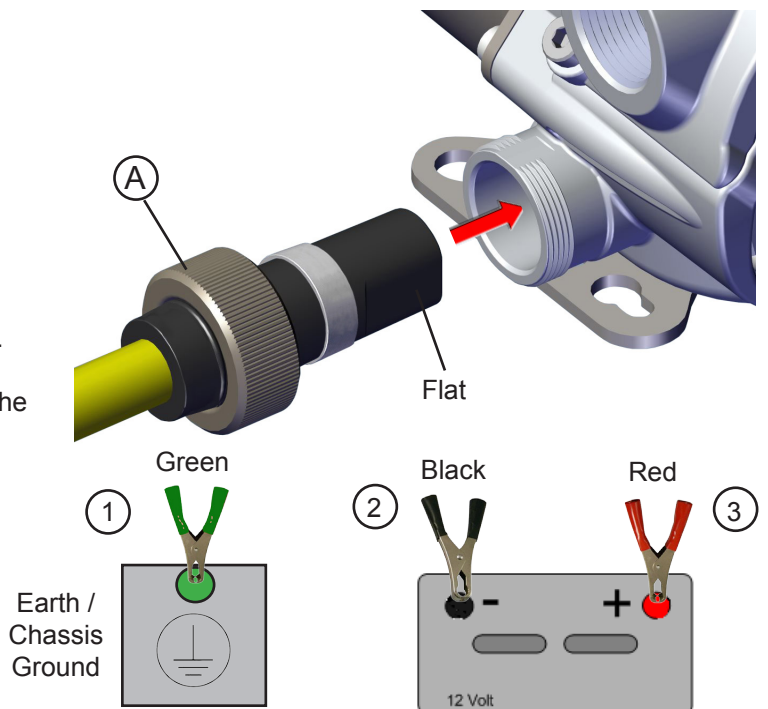

Power Switch



DANGER! Be certain the power switch is “OFF” prior to connecting the battery clamps / power cables to the power source or installing the cable into the pump to prevent unexpected starting of the motor. Unexpected motor start can cause unintended discharge of fuel, creating an explosion and / or fire hazard.



WARNING! The RD series pump body can become hot with extended use. Always use the handle to lift and carry the pump when moving it. Use caution when gripping the handle as exposed skin may be burned if it contacts a hot pump.



IMPORTANT! The RD series pump uses thermal overload protection to prevent overheating. If the pump shuts off due to thermal overload, turn the power switch “OFF”. Once the pump cools the switch can be set to “ON” again to reset the thermal protection.

The RD series pump features a sliding ON / OFF power switch. The switch is located on top of the pump at the back of the pump housing. To operate the pump, push the switch to the desired position. Push “ON” to operate the pump, and push “OFF” to turn the pump off.

NOTE: The side where the switch button is depressed is the function the switch is performing.

Pump off



Pump on



Operational Safety



DANGER! DO NOT use pump in enclosed areas when pumping hazardous or explosive fluids. Pumping area should be well ventilated. Concentrated vapors in an enclosed area are noxious and highly explosive!



WARNING! NEVER disconnect the power cable from the pump while pump is switched on or connected to a power source. **ALWAYS** switch the pump off and disconnect all the clamps from the power source **PRIOR** to disconnecting the power cable from the pump. Electrical shorts, sparks, or unexpected start up can occur.



WARNING! Use caution when operating or carrying the pump. The hoses and electrical power cable can be a trip hazard; caution should be exercised any time the pump is moved with the hoses and power cable connected to avoid tripping or entanglement.



WARNING! Pump assembly can become hot with extended use. Use caution when handling the pump after use; always use the handle to move or hold the pump. Pump has 30 minute on / 30 minute off duty cycle.



CAUTION! DO NOT operate the pump if any part of the explosion proof motor construction is missing or compromised. Disassembly of the motor will compromise the explosion proof design and void any warranty.



CAUTION! DO NOT operate the pump dry for more than 30 seconds. **DO NOT** operate the pump in bypass more than 5 minutes. Damage to the pump will occur.

Troubleshooting

This Troubleshooting guide provides basic diagnostic assistance.



DANGER! DO NOT open or attempt to repair the motor on your Tuthill pump. Return it to the place of purchase for service. Opening the motor case will compromise the integrity of the Explosion Proof construction and void any existing warranty, approvals, and certifications (i.e.: ATEX, UL listing, CE, etc.).



DANGER! Disconnect all power prior to performing any service or maintenance. Failure to disconnect the power may cause electrical shock, or unexpected starting of the motor, resulting in injury or death.

Symptom	Cause	Cure
Pump won't prime.	Suction line problem.	Check suction line for leaks or restrictions; it may be too small in diameter, too long, not air tight, or too low vertically.
	Vanes sticking.	Check vanes for nicks, damage, obstructions, or excess wear. Replace as necessary.
	Excessive rotor, vane, rotor cover, or housing wear.	Inspect rotor, vanes, rotor cover, and housing for excess wear; replace as necessary.
	Inlet / Outlet blocked.	Check pump, hose, nozzle, and filter / strainer for blockage.
	Vapor lock.	Reduce vertical or horizontal distance from pump to liquid.
	Power connections reversed.	Correct power connections.
Low capacity.	Excessive dirt in screen.	Remove and clean screen.
	Suction line problem.	Check suction line for leaks or restrictions; it may be too small in diameter, too long, not air tight, or too low vertically.
	Excessive rotor, vane, rotor cover, or housing wear.	Inspect rotor, vanes, rotor cover, and housing for excess wear; replace as necessary.
	Hose or nozzle damage.	Replace hose or nozzle.
	Low fluid level.	Refill tank.
	Incorrect voltage.	Check incoming line voltage while pump is running.
	Vanes sticking.	Check vanes for nicks, damage, obstructions, or excess wear. Replace as necessary.
	Wiring problem.	Check for loose connections.
	Motor problem.	Return to place of purchase.
Motor stalls / fuse blows.	Short in wiring.	Inspect electrical cable for shorts and replace as necessary.
	Excess rotor or vane wear.	Check vanes for nicks, damage, obstructions, or excess wear. Replace as necessary.
	Pump rotor lock-up.	Clean and inspect rotor and vanes.
	Debris in pump cavity.	Clean debris from pump cavity.
	Components swell from pumping water.	Let pump dry completely.

Bold text indicates repairs that are not serviceable by the owner; pump must be returned to the point of purchase for repairs.

Troubleshooting (cont'd)

Symptom	Cause	Cure
Fluid leakage.	Bad o-ring gasket.	Check all o-rings.
	Bad shaft seal.	Return to place of purchase.
	Incompatible fluid.	Refer to wetted parts list (page 10).
	Loose fasteners.	Tighten fasteners.
	Inadequate plumbing seals.	Reseal plumbing connections.
Pump hums but will not operate.	Motor failure.	Return to place of purchase.
Motor overheats.	Pumping high viscosity fluids.	These fluids can only be pumped for short periods of time (less than the 30 minute duty cycle).
	Clogged screen.	Remove and clean screen.
	Restricted suction pipe.	Remove and clean pipe.
	Motor failure.	Return to place of purchase.
	Pump rotor lock-up.	Clean and inspect rotor and vanes.
	No power.	Check incoming power.
	Switch failure.	Return to place of purchase.
Motor inoperative.	Incorrect or loose wiring.	Check wiring / connections.
	No power.	Check incoming power.
	Switch failure.	Return to place of purchase.
	Motor failure.	Return to place of purchase.
	Motor overheated.	Switch off and allow to cool.
	Incorrect or loose wiring.	Check wiring / connections.
Fuse has blown.	Replace 30A fuse.	

Bold text indicates repairs that are not serviceable by the owner; pump must be returned to the point of purchase for repairs.

Cleaning the Inlet Screen

Regular inspection and cleaning of the inlet screen on your RD series pump helps maintain performance and flow. Access the screen by removing the inlet flange as described on page 5. Clean, rinse, and dry the screen thoroughly before re-installing.

Inspect the screen, seals, and flange area for debris and damage. If screen or O-rings are damaged, replace with kit KIT812SL.

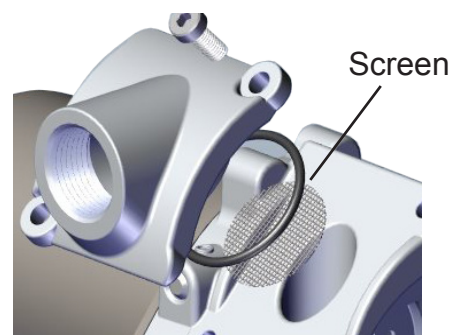

Accessories

Accessory	Description
1200KTF7018	10 Micron Particulate Filter Kit (Bung mount installations only)
F1810PM0	10 Micron Replacement Spin-on Filter (Particulate) (Bung mount installations only)
1210KTF7019	Hydrosorb Filter Kit (Bung mount installations only)
F1810HM0	Hydrosorb Replacement Spin-on filter. (Bung mount installations only)
FRHMN075S	3/4" Manual Nozzle

Technical Information

Motor	RD8	RD12
Power - DC 12, 24, 12/24	12 VDC	12 VDC
HP (horsepower) rating	1/6 HP	1/6 HP
Power cable length	10'	10'
Power cable gauge	14 AWG	14 AWG
Power cable DC battery connectors	Yes	Yes
Amps (FLA)	14 A	14 A
RPM	3600	3600
Duty cycle	30 min. ON / 30 min. OFF	30 min. ON / 30 min. OFF
Thermal Protection	Yes	Yes
Circuit protection fuse	Yes (30 Amp Fuse)	Yes (30 Amp Fuse)
Certification	UL/cUL Motor/CE/ATEX/IECEX Pump	UL/cUL Motor/CE/ATEX/IECEX Pump
Pump		
Type- rotary, diaphragm, gear, vane	Rotary Hinged Vane	Rotary Hinged Vane
Flow Rate (with supplied hose / nozzle)	Up to 8 GPM / 30 LPM	Up to 12 GPM / 45 LPM
Flow Rate open flow - no hose or nozzle	Up to 10 GPM / 38 LPM	Up to 13 GPM / 50 LPM
Max discharge pressure	16 PSI	16 PSI
Dry vac (in Hg)	5 in vacuum	5 in vacuum
Head- Max (ft)	37'	37'
Anti-siphon valve	None	None
Inlet - Size / Thread	3/4" NPT / BSPP	3/4" NPT / BSPP
Outlet - Size / Thread	3/4" NPT / BSPP	3/4" NPT / BSPP
Mount	2" Bung (NPT) / BSPT	2" Bung (NPT) / BSPT
Materials of construction -pump housing	Aluminum	Aluminum
Materials of construction- wetted material	BUNA-N + HNBR	BUNA-N + HNBR
Rotor materials of construction	Nylon	Nylon
Rotor vane material of construction	Acetal	Acetal
Compatible fluids	Diesel, Gasoline, BioDiesel up to B20, E15, Kerosene, Mineral Spirits, Methanol (up to 15%)	Diesel, Gasoline, BioDiesel up to B20, E15, Kerosene, Mineral Spirits, Methanol (up to 15%)
Strainer Mesh Size	20 x 20	20 x 20
Warranty (yr)	2 Year	2 Year
Maximum Sound Level	65 dB (A)	65 dB (A)

Motor Tag Information

The carrying handle on your RD series pump contains important technical, performance, and certification information. For your specific model certification, reference the regulatory marks on your pumps handle. Be certain this handle remains affixed to the pump at all times.



Kits and Parts

Kit Number	Description	Parts
KIT812PC	Power Cable Kit	Quick Connect Power Cable Assembly ⑨ and Instructions*
KIT812PCE	Power Cable Kit (Europe)	Quick Connect Power Cable Assembly ⑨ and Instructions*
KIT812RG KIT1212RG**	Rebuild Kit	Rotor & Vanes ④, Rotor Cover ①, Inlet Screen ⑧, Flange O-rings ⑦, Rotor Cover O-Ring ③, Flange Fasteners ⑥, Rotor Cover Fasteners ②, and Instructions*
KIT812FL	Single Flange Kit (NPT)	Flange ⑤, Inlet Screen ⑧, Flange O-Ring ⑦, Flange Fasteners ⑥, and Instructions*
KIT812FLB	Single Flange Kit (BSPP)	Flange ⑤, Inlet Screen ⑧, Flange O-Ring ⑦, Flange Fasteners ⑥, and Instructions*
KIT812SL	Seal Kit	Inlet Screen ⑧, Flange O-rings ⑦, Rotor Cover O-Ring ③, Flange Fasteners ⑥, Rotor Cover Fasteners ②, and Instructions*
KIT812NH	Hose Kit	3/4" x 6' Suction Hose [◊] , 5/8" x 8' Discharge Hose [◊] , PTFE Tape*, and Instructions*
KIT1212NH**	Hose Kit	3/4" x 6' Suction Hose [◊] , 3/4" x 8' Discharge Hose [◊] , PTFE Tape*, and Instructions*
KIT812NP	Bung Mount Kit	Suction Tube [◊] , Bung Adapter [◊] , Nipple [◊] , Nozzle Boot [◊] , Nozzle Boot Fasteners [◊] , PTFE Tape*, Instructions*

*Item not shown.

**Kit for RD12 Application

◊Item shown on page 4 and 5.

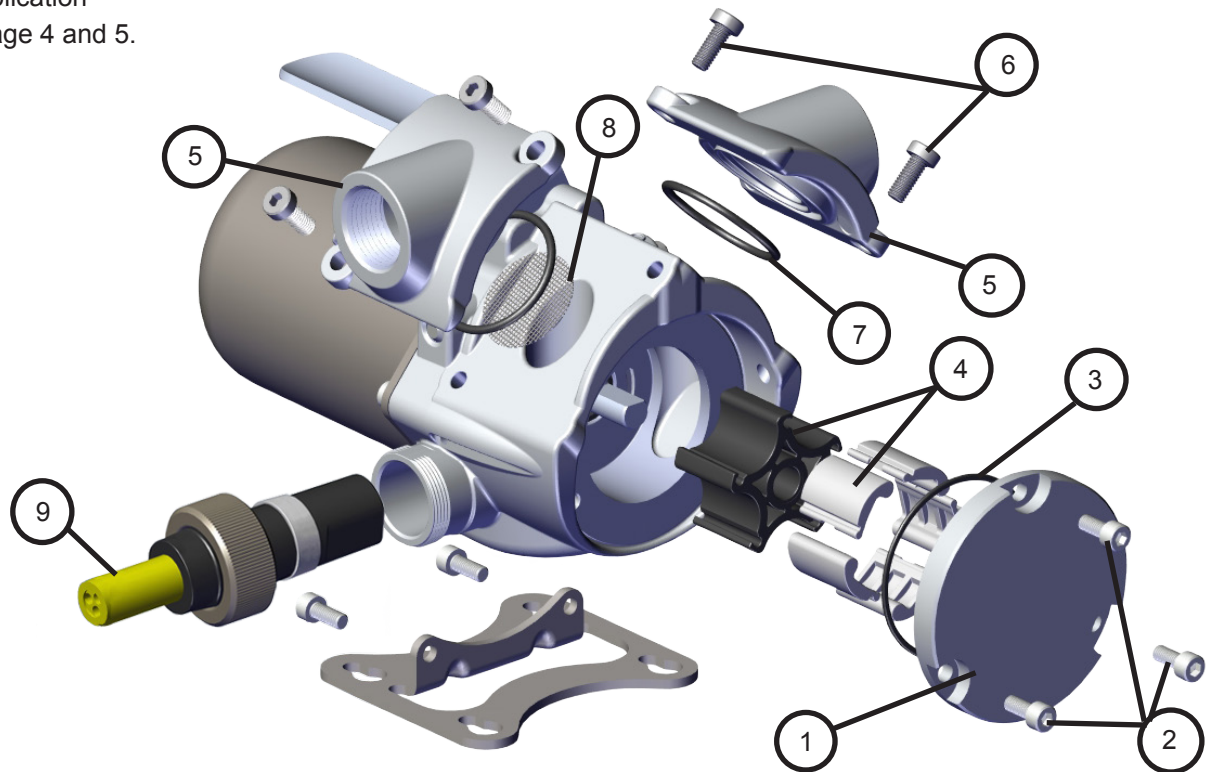

Safety Testing Certifications

This Fill-Rite line of pumps have been safety tested for compliance to strict regulatory standards. Check the information on the handle of your pump to determine the certifications that are applicable to your particular model.

Certification testing information is located on the back cover of this manual.

Safety Testing Information

The following standards were used to show compliance in North America:

UL 674 – Electric Motors and Generators for Use in Division 1 Hazardous (Classified) Locations, 5th Edition. The following standards were used to show compliance in the European Union:

Directive 2014/34/EU – Equipment and protective systems intended for use in potentially explosive atmospheres.

EN 60079-0:2012 Explosive atmospheres – Part 0: Equipment – General requirement.

EN 60079-1:2014 Explosive atmospheres – Part 1: Equipment protection by flameproof enclosures “d”.*

IEC 60079-0 Explosive atmospheres – Part 0: Equipment – General requirements, 6th Edition.

IEC 60079-1 Explosive atmospheres – Part 1: Equipment protection by flameproof enclosures “d”, 7th Edition. Directive 2006/42/EC – Directive on machinery.

EN 809:1998 +A:2009 – Pumps and pump units for liquids – Common safety requirements.

EN ISO 12100:2010 – Safety of Machinery – Basic concepts, general principles for design.

Directive 2004/108/EC – Electromagnetic compatibility.

Directive 2011/65/EU – Restrictions of the use of certain hazardous substances in electrical and electronic equipment.

*The minimum and maximum values of the flameproof joints differ from what is specified in Table 2 of EN60079-1:2014. Manufacturer is to be contacted for information on the dimensions of the flameproof joints.

*The fasteners used to secure the steel can to the aluminum housing have a yield strength of 1100MPa.

FILL-RITE[®]
The Most Trusted Name in Pumps and Meters