

# SOTERA<sup>®</sup>

SYSTEMS

Owner's Operation and Safety Manual

## 400B Series Electric Diaphragm Pumps



PROUDLY  
Made in  
USA

 **Tuthill**

# SOTERA™ SYSTEMS

## SERIES 400B DIAPHRAGM PUMP

For Chemical & Lubricant Transfer

### Owner's Operation & Safety Manual All 400B, FR205B, and FR210B Models

**WARNING!** This pump shall not be used to fuel any vehicles or aircraft!

**WARNING!** This pump is not suited for use with fluids for human consumption.

**WARNING!** Electrical wiring should be performed ONLY by a licensed electrician in compliance with local, state, and national electrical code NEC/ANSI/NFPA 70, NFPA 30, and NFPA 30A, as appropriate to the intended use of the pump. Threaded rigid conduit, sealed fittings, and conductor seal should be used where applicable. The pump must be properly grounded. Improper installation or use of this pump can result in serious bodily injury, or death!

**WARNING!** To ensure safe and proper operation of your equipment, it is critical to read and adhere to all of the following safety warnings and precautions. Improper installation or use of this product can cause serious bodily injury or death!

**WARNING!** The pump motor is equipped with thermal overload protection. If overheated, it will shut itself off without any damage to the windings. Be sure to turn off the pump power if this occurs. As the motor cools, it will start without warning if power is on.

#### SAFETY INSTRUCTIONS

1. Threaded pipe joints and connections must be sealed with the appropriate sealant or sealant tape to minimize the possibility of leaks. Leaking of caustic and/or hazardous fluids could result in severe injuries.
2. Never disassemble YOKE ASSEMBLY (see item 23 page 5). This is under extreme pressure and injury could result.
3. Tank or barrel should be anchored to prevent tipping in both the full and empty conditions.

#### GENERAL DESCRIPTION

The Sotera Systems 400B is a self priming, positive displacement double action diaphragm pump. It features flow rates up to 13 GPM, and has polypropylene and stainless steel wetted parts, and chemical compatible seals. It is designed for low pressure transfer of non-flammable fluids.

#### TECHNICAL INFORMATION

##### Design Features

- 1" suction & discharge ports
- 15 PSI (1 Bar) maximum outlet pressure
- Positive displacement/self priming design
- 8" Hg "dry" lift (9 feet of water)
- 2600 RPM, 1/4 HP (185 Watts) motor options:
  - 12 VDC rated at 20 amps
  - 12 VDC rated at 20 amps Explosion Proof UL Listed
  - 12 VDC rated at 20 amps CE Certified
  - 24 VDC rated at 10 amps Explosion Proof UL Listed
  - 115 VAC / 60Hz rated at 2.5 amps
  - 115 VAC rated at 2.5 amps Explosion Proof UL Listed
- Thermal overload protection of the motor
- Power Cables:
  - 12 VDC: 20' (6m) power cable with battery clips w/30 amp fuse
  - 24 VDC: 15' (4.6m) power cable (no clips or fuse)
  - 115 VAC: 6.6' (2m) power cable with 3-prong grounded plug- in connector (std. motor, non-UL)
  - 115 VAC: 12' (3.7m) power cable with 3-prong grounded plug- in connector (Explosion Proof UL Listed Motor)
- Maximum particle size up to 0.100" diameter
- Pump can run dry without damage
- Handles viscosities up to 3700 CPS (see page 4)
- Can pump shear sensitive fluids
- Operating Temperature Range: -10°F (-23°C) to 130°F (54°C)
- Maximum 30 minute duty cycle, **NOT** for continuous operation
- Maximum sound level: 76.6 dBA

##### Fluid Compatibility

The 400B Series pump is compatible with most agricultural and industrial chemicals, and lubricants. Model numbers reference the diaphragm material. Always refer to the Sotera Chemical Resistance Guide at [sotera.com](http://sotera.com) to determine proper materials of construction for the fluids you pump.

- Models that begin with "SS" (example SS415B) contain Santoprene® diaphragms designed for use with chemicals.\*
- Models that begin with "FR" (example FR410B) contain Hytrel® diaphragms designed for use with oils and lubricating fluids.

##### The 400 Series pump is NOT compatible with:

- Strong acids (pH of 3.5 or below)
- Strong bases (pH above 12)
- Flammable fluids (flash point below 100°F / 38° C)
- Bleach (Sodium Hypochlorite)

##### Wetted Materials

Always refer to Chemical Resistance Guide at [sotera.com](http://sotera.com) for specific compaibility information.

- Polypropylene body and valves
- Stainless Steel fasteners
- Hastelloy check valve springs
- Hytrel, Buna-N, EPDM, and Flouorocarbon seals
- Santoprene and Hytrel Diaphragms

## OPTIONS

- 825 or 850 digital meters, w/optional pulse output
- 2" NPT metallic or non-metallic inlet bung
- Wrap around tubular mounting frame
- UL listed Explosion Proof Motors
- CE Certified Motors
- Santoprene® or Hytrel® diaphragm

## MECHANICAL INSTALLATION

**WARNING!** Threaded pipe joints and connections must be sealed with appropriate sealeant or sealant tape to prevent possible leaks.

**WARNING!** In mobile tank applications, be sure the tank is properly secured so it cannot shift or move whether the tank is empty or full.

**CAUTION!** Do not use additional check valves or foot valves unless they have a proper pressure relief valve built into them. Note that additional check valves will reduce rate of flow.

- IMPORTANT!** To maximize performance and longevity of your new 400B series pump:
- Do not over tighten non-metallic fittings.
  - Tanks and containers must be vented to prevent collapses.
  - Do not use the pump for the structural support of the piping system. Be certain the system components are properly supported to prevent stress on the pump parts. Suction and discharge connections should be flexible connections (such as hose), not rigid piped, and should be compatible with the substance being pumped.
  - **Suction Installation Best Practices**
    - Use a 10 mesh screen (or higher mesh) on the suction inlet if there are solids or debris in the fluid to be pumped.
    - Suction lift should not exceed 9 feet (2.7m) for water.
    - Suction pipe should be 1" diameter or larger. It should terminate 2" from the bottom of the tank unless the fluid is known to have no contaminants
    - **Suction hose should be reinforced to prevent collapse.**
  - **Discharge Installation Best Practices**
    - Use at least 1" discharge hose
    - Use compatible hose:
      - EPDM for chemicals
      - Nitrile (Buna-N) for oils and lubricants
  - Long hoses will reduce flow. For best performance, use downstream components and / or accessories that minimize restriction of flow. See Viscosity Correction Chart on page 4 to estimate flow rate based on fluid viscosity and hose length.

## ELECTRICAL INSTALLATION

**DANGER!** Be certain the power switch is "OFF" prior to connecting the battery clamps / power cables to the power source to prevent unexpected starting of the motor. Unexpected motor start can cause unintended discharge of fluid, creating explosion / fire / chemical spill hazards.

**WARNING! NEVER** disconnect the power cable while pump is switched on. **ALWAYS switch the pump off PRIOR to disconnecting all the battery clamps or plug from the power source.** Electrical shorts, sparks, or unexpected start up can occur.

### DC Power

**CAUTION!** DC powered pumps are designed to operate on either 12 or 24 VDC (depending on model). Where applicable, use the supplied battery cable to supply power to the pump from a 12 or 24 VDC battery. A 30 amp fuse (20 amp fuse on 24 VDC motors) should be installed on the battery cable (see wiring diagram below) to protect the wire in case of electrical short.

Inspect power cable before each use! Damage to the outer jacket of the cable that exposes wiring requires replacement of the power cable. The power cable terminates in black and red clamps. Pumps with Explosion Proof motors also come with a ground wire.

1. **If so equipped**, the ground wire should be connected first. Connect the ground wire to the vehicle chassis or earth ground. **DO NOT** connect the ground wire to the negative power source post.
2. Next, connect the black (negative) clamp to the negative post of the DC power source.
3. Connect the red (positive) clamp to the positive post last.

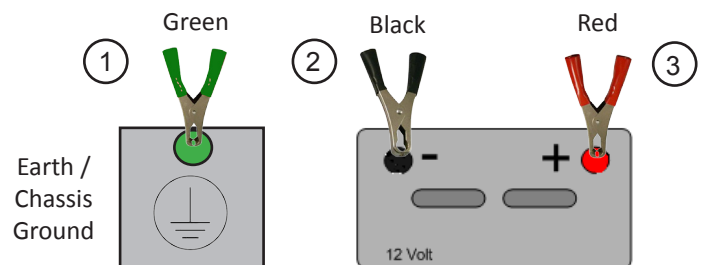

### AC Power

**WARNING!** Electrical wiring should be performed **ONLY** by a licensed electrician in compliance with local, state, and national electrical code NEC/ANSI/NFPA 70, NFPA30, and NFPA 30A, as appropriate to the intended use of the pump. **The pump must be properly grounded.** Improper installation or use of this pump can result in serious bodily injury, or death!

**WARNING!** Do NOT disable ground prong. Removing or bypassing the ground prong on a plug eliminates the ground connection. Always plug the pump into an approved grounded electrical outlet for safe operation.



**CAUTION!** All pumps should operate at the rated nameplate voltage. AC power should be supplied to the pump from a dedicated circuit with 15 amp circuit protection. No other equipment should be powered by this circuit. Wiring must be of sufficient size to carry the correct current for the pump (minimum 12 gauge). Voltage drop will vary with distance to pump and size of wire; refer to the National Electrical Code (NEC), or local codes, for voltage drop compensation to be sure you are using the correct size wire for your application.

### AC Only

- 115VAC, 60Hz, 2.5 Amps, 1/4 Hp (185 watts) motor, std.
  - 115VAC, 60Hz, 2.5 Amps, 1/4 Hp (185 watts) motor, Explosion Proof UL Listed
- A. All wiring must be done by a licensed electrician in accordance with approved electrical codes.
  - B. Power must be supplied by a licensed electrician in accordance with approved electrical codes.
  - C. Circuit must be grounded.
  - D. Power cable must be protected from sharp edges.

### Best Practices

Regular maintenance is critical to maintaining performance and extending the life of your 400 series pump.

**WARNING!** Always switch pump off and disconnect from power source prior to servicing!

**WARNING!** Always flush pump completely prior to any service or disassembly. Use water, or an appropriate flushing fluid for the fluids being pumped. **DO NOT USE PRESSURIZED WATER OR PRESSURIZED AIR** to flush your Sotera Systems pumps. Damage to the equipment will occur if flush water pressure exceeds 15 psi (1 bar). Instead, submerge the suction tube or inlet adapter in clean water and dispense water by operating the pump. Dispose of the flush water properly. After flushing, pump air to remove as much water as possible.

**WARNING!** DO NOT disassemble the yoke assembly. It is under extreme pressure, and serious injury or death may result!

**IMPORTANT!** Do not allow chemicals to remain in the pump for any extended period of time, whereby the chemicals area allowed to “dry out.” Thoroughly rinse pump and meter by flushing the pump with water or appropriate flushing fluid.

**IMPORTANT!** The pump body is filled with oil at the factory to lubricate the internal gear drive mechanism for the diaphragms. Certain repair and maintenance procedures require draining of the oil, while others do not. If you need to drain the oil, remove one fluid sight cap (item 30) from the pump body. Stand the pump on its end and drain the oil via the sight cap port into a container approved for standard 30W motor oil. Always use new oil after draining

### Routine Annual Maintenance or as needed.

(Reference page 5 for item numbers.)

1. Tighten all external torx head screws to 75 in. lbs. (items 9 & 17).
2. Drain oil through sight caps and replace oil with approximately 16 ounces of automotive grade SAE 30W through one of the sight cap holes. The oil level should be level with the bottom edge of the sight caps (item 3) located on the front of the pump body.

**NOTE:** Always check oil level when the pump is level

**NOTE:** If external torx head screws (items 9 & 17) are removed, hand start and tighten to 75 in. lbs. Tighten motor flange hex head screws to 50 in lbs.

### Diaphragm Assembly/Check Valve Replacement

**IMPORTANT!** Diaphragms and check valve assemblies can be serviced without removing oil from pump body by servicing one side at a time with diaphragm facing up. It is important during this procedure to make sure no debris or contaminants fall into the oil.

1. Remove 8 diaphragm cover screws (Torx T30) and diaphragm cover (item 9).
2. Remove retainer screws (item 26) and o-rings (item 25) (Phillips Head #2)

**CAUTION! USE CARE** in removing the diaphragm and check valve assemblies from the pump body to avoid damage to the pump body. **DO NOT** pry the diaphragm / check valve assembly away from the pump body with sharp or metal tools. Scratching or otherwise damaging the pump body may cause leaks.

3. Remove diaphragm assembly by pulling check valves out of pump body; **be careful not to damage surface of body.**
4. Install new diaphragm assembly in the same orientation as the one that was removed.
5. Insert four screws (item 26) and o-rings (item 25) into diaphragm as shown and tighten to 35 in. lbs. of torque.
6. Install diaphragm cover (item 28). **Hand start** and tighten torx head screws to 75 in. lbs.

## Diaphragm Assembly/Check Valve Replacement (cont'd)

To further disassemble pump, after #3 above:

7. Remove motor and drain oil, if complete disassembly is required (motor removal instructions below).
8. Remove 4 screws (item 9) holding bearing plate (item 8). (Torx T30)
9. Remove bearing plate (item 8) and thrust plate (item 7).
10. Remove drive shaft (item 6), bearing (item 5), bearing ring (item 4) and yoke assembly (item 23).

**WARNING!** DO NOT disassemble the **yoke assembly (item 23)**. It is under extreme pressure, and serious injury or death may result!

Assembly in reverse order. Hand start and tighten torx head screws to 75 in. lbs.

**Motor/Gear Assembly Removal** (Refer to exploded view of pump on page 5.)

1. If possible, position pump with sight caps down.
2. Remove four screws (item 17) and lift out motor/gear assembly (items 11 - 16).
3. Drain oil from pump if additional maintenance to pump is required.

## Gear Assembly Replacement

1. Remove six screws (item 11) and pull gear assembly from motor (item 12).
2. Pull drive gear (item 13) and key (item 14) from motor shaft.

**WARNING!** DO NOT DISASSEMBLE GEAR ASSEMBLY. Planet gears and ring gear are marked for proper assembly and must not be altered. **DO NOT ATTEMPT TO REPLACE INDIVIDUAL PARTS. REPLACE ENTIRE ASSEMBLY WHEN REQUIRED** (Kit 400F6557).

## Viscosity Correction Chart

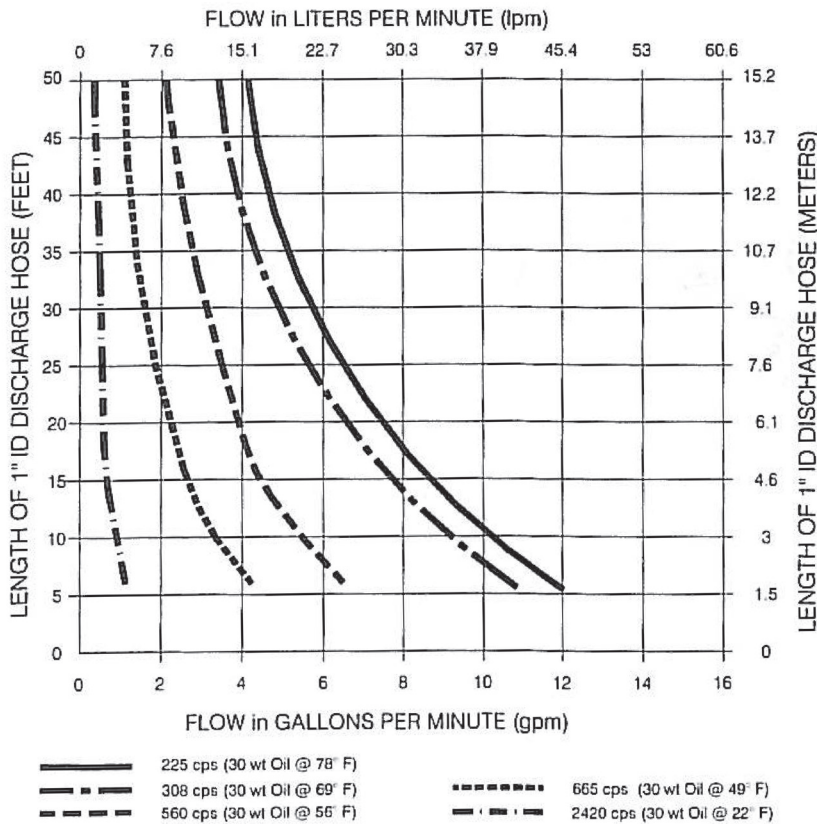

### NOTES:

#### 1. SUCTION LOSSES

Test pump was mounted on a 55 gallon drum of oil, 1/2 full. A SOTERA 1" suction pipe was used. A longer or smaller diameter inlet pipe will lower the flow rate.

#### 2. VERTICAL HEAD LOSSES

Test hose was horizontal with pump. Add 3 feet of hose for each 1 foot of vertical rise.

#### 3. OTHER LOSSES

Elbows, quick-disconnects, swivels, and check valves in outlet or inlet hoses will restrict the flow. Add the estimated length of hose for each component used.

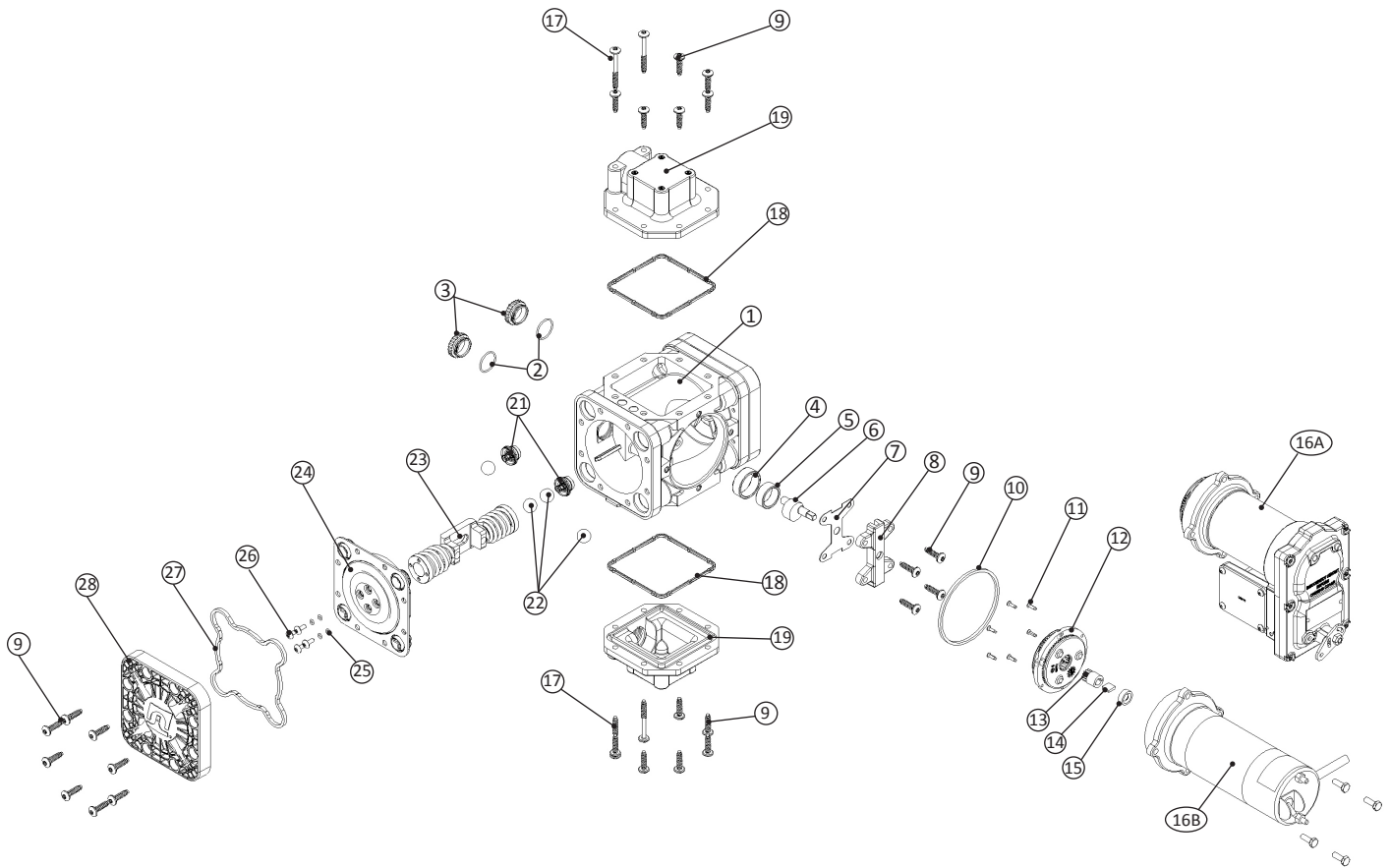

## Parts List

Item	Description	Qty
1	Pump Body	1
2	O-Ring Nitrile, -022	2
3	Sight Cap	2
4	Bearing Ring	1
5	Bushing, 1.250 OD. x 1.00 ID.	1
6	Drive Shaft	1
7	Thrust Plate	1
8	Bearing Plate	1
9	Screw, 1/4 - 10 x 1.00 PTS-SS	32
10	O-Ring, Lathe Cut Nitrile	1
11	Screw, 6-32 Flat Head Trilobular	6
12	Gear Pack Assembly	1
13	Drive Gear	1
14	Key, Rotor	1

Item	UL Listed / CE Certified Motors	Qty
16A	12V DC CE Compliant Explosion Proof	1
16A	12V DC UL Listed Explosion Proof	1
16A	24V DC UL Listed Explosion Proof	1
16A	115V AC UL Listed Explosion Proof	1

Item	Description	Qty
15	Shaft Lip Seal, 400 Motor Shaft	1
16A 16B	Motor Assembly (see charts below for motor specifics)	1
17	Screw, 1/4 - 10 x 2.25 PTS-SS	4
18	Flange Gasket - EPDM	2
19	90 Degree Flange with Inserts	2
20	Screw, 1/4 - 20 x .750 LG	4
21	Outlet Check Valve	4
22	Ball	8
23	Yoke Assembly	1
24	Diaphragm Assembly	2
25	O-Ring, EPDM, -007	8
26	PHM Screw, 10 - 24 x .5 LG	8
27	Diaphragm Cover Gasket - EPDM	2
28	Diaphragm Covers	2

Item	Standard Duty Motors	Qty
16B	12V DC	1
16B	115V AC	1

When ordering kits or parts, be sure to give the replacement part number, date of manufacture, and pump serial number. This will ensure the correct part is ordered.

# Model 445 Mix & Go

Item	Description	Qty
1	Screw 1/4 -10 x 2.25	2
2	Screw 1/4 -10 x 1.00	12
3	Outlet flange	1
4A	Flange gasket - EPDM	2
4B	Flange gasket - Nitrile	2
5	Pump cap	1
6A	O-Ring - EPDM	1
6B	O-Ring - Fluorocarbon	1
7	Vent	1
8	O-Ring - EPDM	1
9	Inlet flange	1
10	Butterfly valve - recirculation	1
11	Valve shaft	1
12A	O-Ring - EPDM	1
12B	O-Ring - Fluorocarbon	1
13	Bushing	1
14	Screw 0.138	2
15	Handle - recirculation flange	1
16A	Recirculation spout - EPDM	1
16B	Recirculation spout - Fluorocarbon	1
17	Gasket - EPDM (foam adhesive)	1
18	O-Ring - EPDM	8
19	Screw 1/4 -10 x 1.25	2

**NOTE:** Kits for the 445 Series Pumps are on page 9.

**2011 EPA 165.45 No Back-Fill One Way Outlet Valve**



Model 445 Mix & Go pump with one-way valve on outlet (2011 EPA 165.45 no-backfilling mandate). Valve is compliant with tamper proof wire routed through:

- Eyelet in valve (A)
- Eyelet in pump base (B)
- Eyelet on tank (C)
- Tamper-proof wire: .....

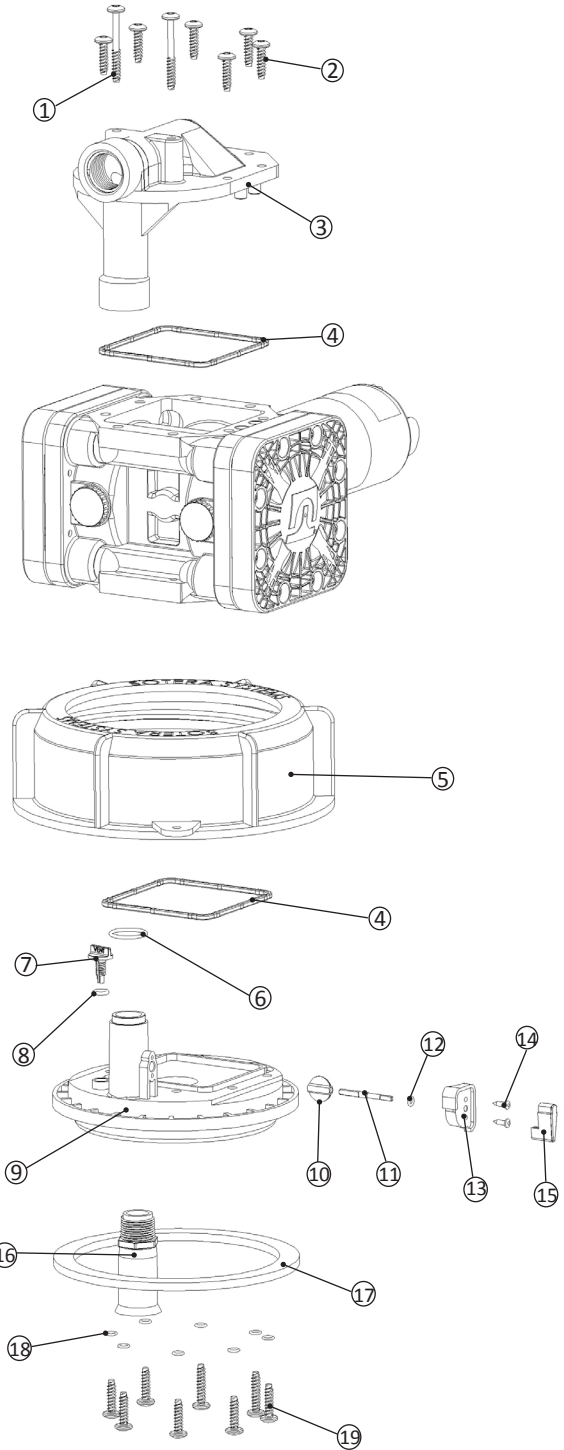

### Mixing

Move handle (item 15) so it is pointing downward. Shut off downstream fluid valve. Turn on pump motor, and allow the system to mix per the chemical manufacturers instructions.

**!** **IMPORTANT!** Open vent (item 7) 3 full turns counter-clockwise before dispensing fluid. Close vent when finished dispensing by turning clockwise until tight.

# SS 435 Chemtraveller®

# SS 465 Chemtraveller®

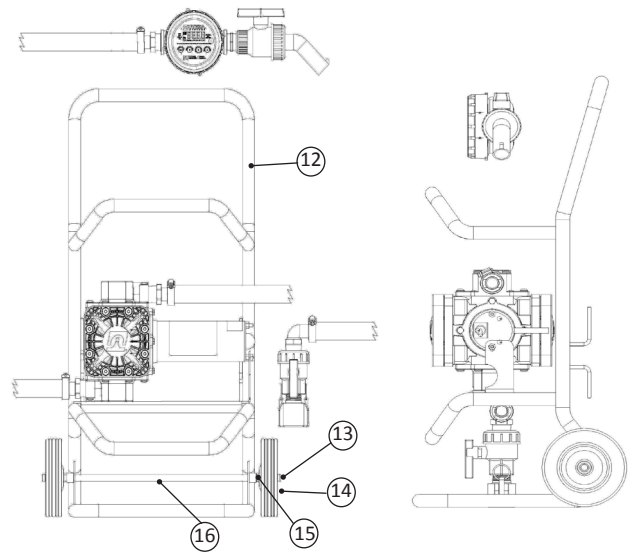
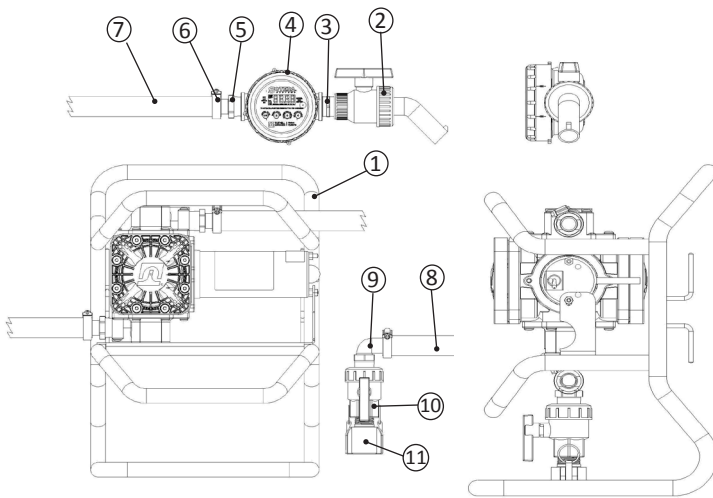

Bill of Materials	
Item	Description
1	Short Frame
2	1" Valve/Nozzle
3	1" Poly Short Nipple
4	825 Meter
5	1" Hose Barb
6	Hose Clamp
7	1" x 12' EPDM Discharge Hose
8	1" x 9' EPDM Suction Hose
9	1" Poly Street Elbow
10	1" Ball Valve
11	1" Female Coupler
12	Tall Frame
13	Push Nut
14	Wheel, 6" x 1.5"
15	Spacer
16	Shaft, 1/2" Diameter x 19.5" Long
17	1" Male Adaptor
18	Double Tap Bushing
19	Suction Tube
20	2" Female Coupler
21	2" Male Coupler
22	2" x 1" Reducer Bushing

Kit Number	Includes
400KTG8830	2, 3, 4, 5, (2) 6, 7
400KTG9342	17, 11, 10, 18, 9, 445F1863 Suction Tube
400KTG9341	20, 21, 22, 3, 10
400KTF6867	(2) 13, (2) 14, (2) 15, 16
400KTF6853	12, 400F6679 Flange & Hardware

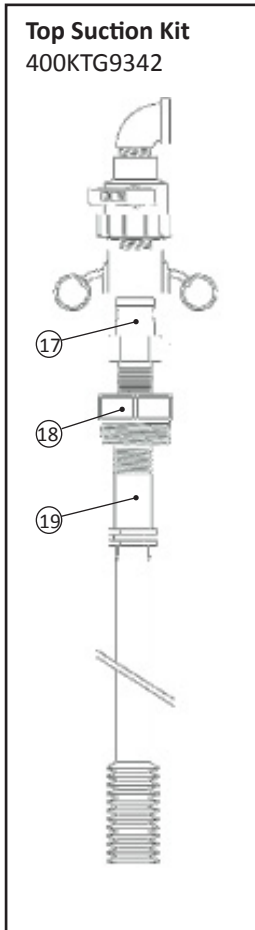
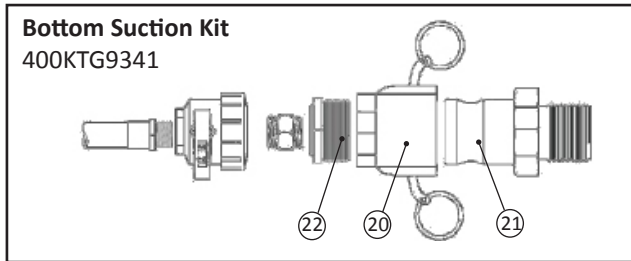

**KIT 400KTG9341 Instructions**

1. Use PTFE tape or thread sealant on all joints.
2. Thread 2" cam adapter (item 21) into tank discharge valve and tighten.
3. Assemble remaining fittings as shown.
4. Close valve on pump outlet hose.
5. Connect cam Adapter (item 21) on suction hose to tank.
6. Open tank valve, then open suction hose valve.
7. Close tank valve when dispensing is complete.

**KIT 400KTG9342 Instructions**

1. Use PTFE tape or thread sealant on all joints.
2. Install suction tube (item 19) and adapter (item 17) into bushing (item 18) and tighten.
3. Extend suction tube (item 19) to required length, then install bushing (item 18) on drum.
4. Install other components as shown.
5. Engage coupler adapter and open ball valve.
6. Close ball valve and disconnect coupler to remove. Allow fluid to drain into tank.

## Inlet Configuration Options

Item	Inlet Configuration AA		Inlet Thread	Mounting Thread
A	400F6569	FLANGE STRAIGHT PLASTIC WITH INSERTS	1" NPT	N/A
B	400G9140	BUNG ADAPTER 400 MACHINED PAINTED BLK	N/A	2" NPT
C	400F6792	SCREW 0.250 20 0.750 HHCS SS	N/A	N/A
<b>Inlet Configuration BB</b>				
D	400G9493	FLANGE METAL SAE THREADS ANODIZED	1 5/16" - 12 SAE	N/A
<b>Inlet Configuration CC</b>				
E	400G8071	FLANGE 2" NPT PUMP	1" NPT	2" NPT
<b>Inlet Configuration DD</b>				
F	N/A	CAP ADAPTOR	N/A	N/A
G	N/A	FLANGE STRAIGHT PLASTIC WITH INSERTS	1" NPT	N/A
H	N/A	COLLAR THREADED	N/A	N/A
J	N/A	FLANGE PUMP	N/A	N/A
K	N/A	SCREW 0.250 20 0.750 FHMS SS	N/A <td N/A	
L	N/A	PUMP PROBE	N/A	N/A
M	N/A	O-RING 218 VITON 75	N/A	N/A
N	N/A	ADAPTER 2" BUTTRESS	1" NPT	2" Buttress
O	N/A	ADAPTER 2" NPT TANK	1" NPT	2" NPT
<b>Inlet Configuration EE</b>				
P1	400F6679	90 ° Inlet, NPT Threads	1" NPT	N/A
<b>Inlet Configuration FF</b>				
P2	KITS400FLGBSP	90 ° Inlet, BSPP Threads	1" BSPP	N/A

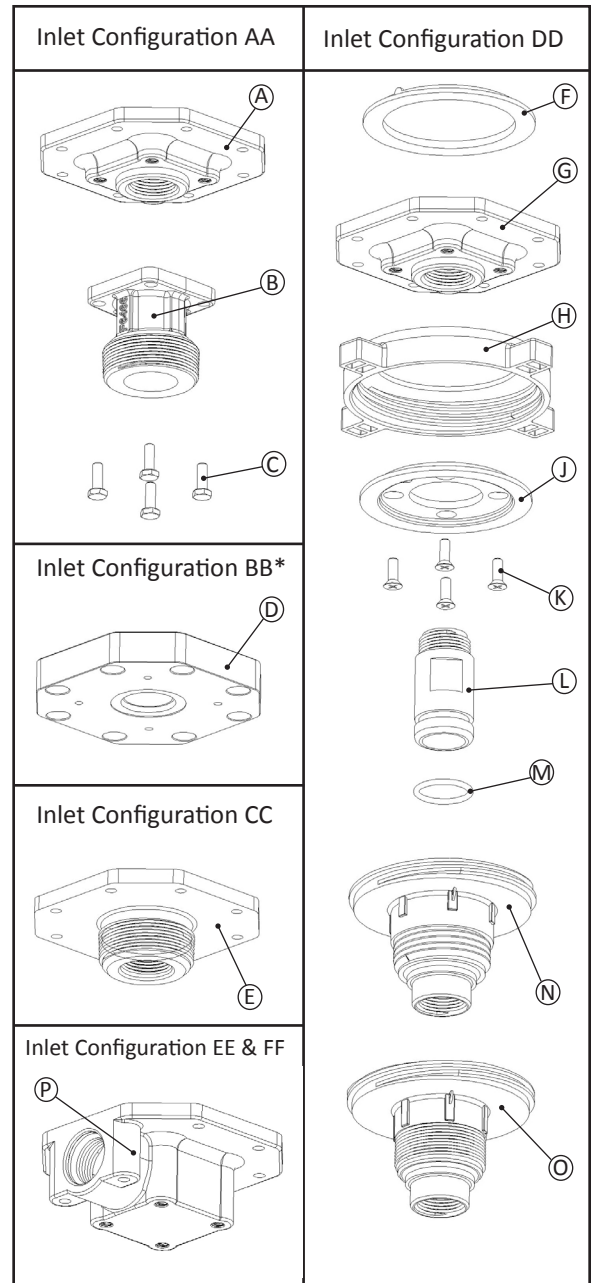

\*Outlet is also this flange

## Inlet Kits

Kit Number	Description	Includes
400KTG8106	Quick Attach Kit, 2" NPT, and Buttress	F-O & R
400KTG8583	Quick Attach Cap	F & H
400KTG9028	Quick Attach 2" NPT Adapter	O, F, H, R
400KTG9029	Quick Attach 2" Buttress Adapter	N, F, H, R

## Suction Tube Options

Item	Part Number	Description	Qty
Q	1200KTG9099	Steel Extendable Suction Tube	1
R	400F1855	Poly Extendable Suction Tube	1
S	445F1863	Poly Extendable Suction Tube with Bellows End	1

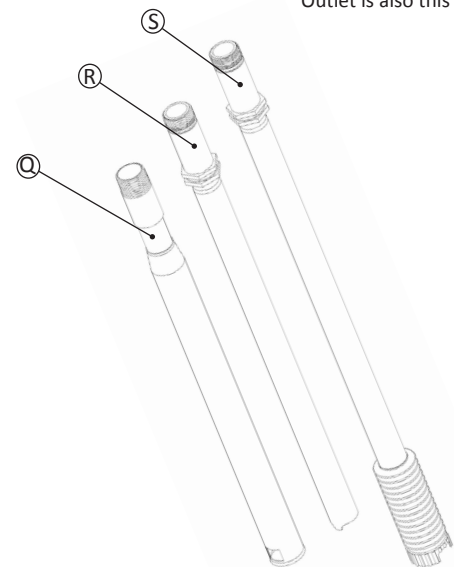

## Kits

Kit	Description	*Kit Contains / (Qty)
400KTF6862	400 (Pre B) Hytrel Rebuild	Similar to 400KTH1456 but for A Series Pumps
400KTF6863	400 (Pre B) Santoprene Rebuild	Similar to 400KTH1457 but for A Series Pumps
400KTG9137	400 (Pre B) Santoprene Diaphragms	Similar to (2) 400KTH1178 but for A Series Pumps
400KTG9168	Retrofit for Pump and Meter	400KTG9137, 445KTG9128, 825KTG9123
400KTH1178	400B Santoprene Diaphragm	24, 18, 27, 28, (2) 21, (4) 25, (4) 26, (4) 22
400KTH1179	400B Hytrel Diaphragm	24, 18, 27, 28, (2) 21, (4) 25, (4) 26, (4) 22
400KTH1456	400B Hytrel Rebuild	(2) 400KTH1179, 10, (6) 11, 12, 13, 14
400KTH1457	400B Santoprene Rebuild	(2) 400KTH1178, 10, (6) 11, 12, 13, 15
400F6557	Gear Pack	12
400F6781	Yoke Assembly	23
400H1401	Site Cap Assembly	3, 2
400EXPF6846	Motor Assy, 12V DC UL Listed Exp. Proof	16A, 15, 14, 13, 12, (6) 11
400EXPF7351	Motor Assy, 115V AC UL Listed Exp. Proof	16A, 15, 14, 13, 12, (6) 11
400G9734	Motor Assy, 12V DC	16B, 15, 14, 13, 12, (6) 11
400G9735	Motor Assy, 115V AC	16B, 15, 14, 13, 12, (6) 11
KITS400MS24VUL	Motor Assy, 24V DC UL Listed Exp. Proof	16A, 15, 14, 13, 12, (6) 11
KITS400MS12VCE	Motor Assy, 12V DC CE Compliant Exp. Proof	16A, 15, 14, 13, 12, (6) 11
445KTG9128	445 EPDM Seal**	16,8,6,4
445KTH1492	445 Recirculation Valve Rebuild**	1, 11, 12, 13, (2) 14, 15

\*Reference Master Parts Matrix on (page 5)

\*\*Kit for SS445 Models ONLY (page 6)

## Accessory Options

Item	Part Number	Description	Qty
<b>Meters</b>			
a1	825	Digital Meter	1
a2	825X700	Digital Meter, EPDM	1
a3	825P	Digital Meter, Pulse Output	1
b1	850	Digital Meter w / Air Sensor	1
b2	850P	Digital Meter w / Air Sensor, Pulse Output	1
<b>Nozzles</b>			
c	FRHMN100S	1" Aluminum Manual Nozzle	1
d	400G7006	Valve Nozzle Polypropylene	1
e1	400KTF0237	Anti-Drip SpoutKit Viton	1
e2	435G9126	Anti-Drip Spout Kit EPDM	4
<b>Hoses</b>			
f1	700F3123	Hose, 1" X 12', EPDM, Discharge	1
f2	435F3455	Hose, 1" X 9', EPDM, Suction	1
f3	400H0547	Hose, 1" x 39", EPDM, Suction	1
f4	FRH10012	Hose, Nitrile, Discharge	1

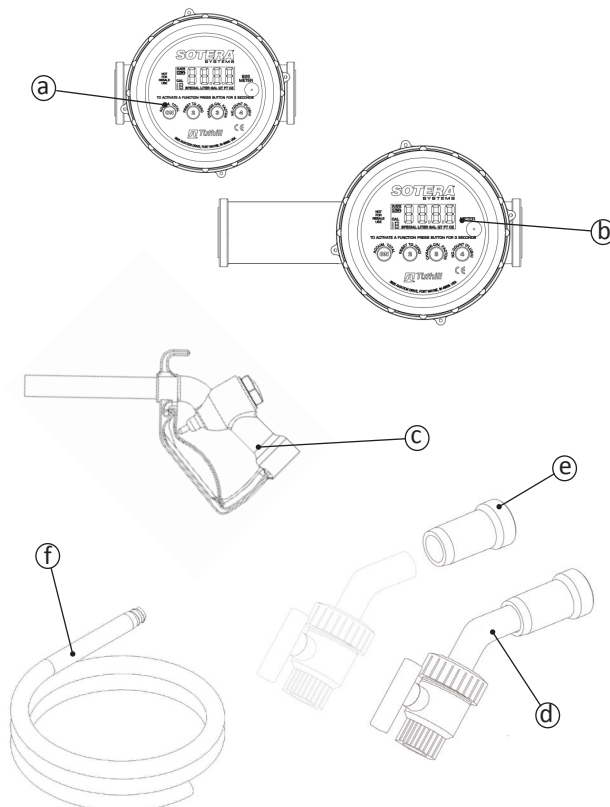

## Anti-Drip Nozzle Spout Kit 400KTF0237

For use with Norwesco and other nozzles with a 1 - 3/16" outside diameter.

### Installation

1. If there is a raised plastic notch on the nozzle, carefully remove it with a file before installing the Anti-Drip Spout.
2. Apply soapy water to the end to aid in the installation. Place the Anti-Drip Spout on the nozzle as shown. Tap the spout with a rubber mallet until it is fully engaged. The space between the end of the spout and the bend in the nozzle should be slightly more than 1-3/4" when pressed fully into place.

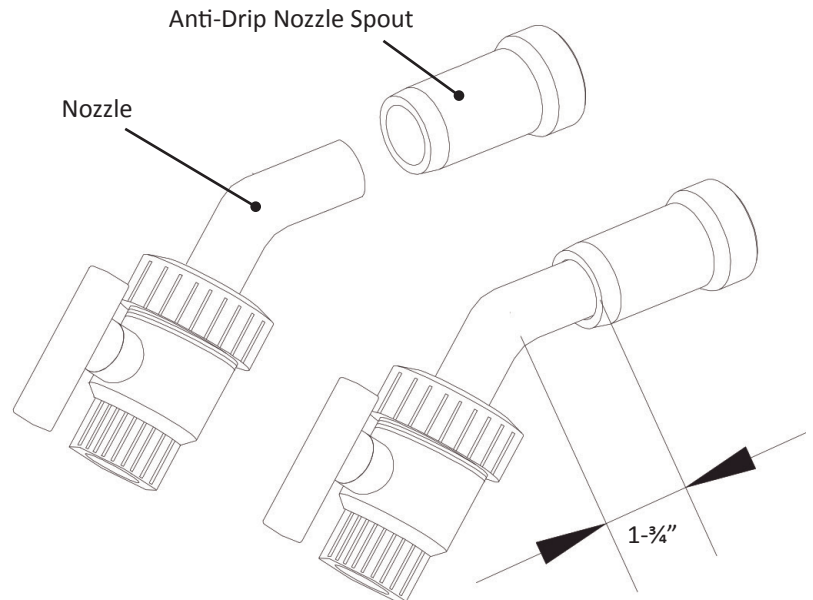

### Proper Use

1. Place the nozzle into the container to be filled **BEFORE** turning the pump on.
2. After pumping, shut off the valve handle, then gently shake the nozzle **BEFORE** removing it from the container. The spout will open when it senses pressure greater than one (1) pound per square inch (psi). **Flow restriction will be minimal.**

## Diaphragm and Check Valve Orientation Detail

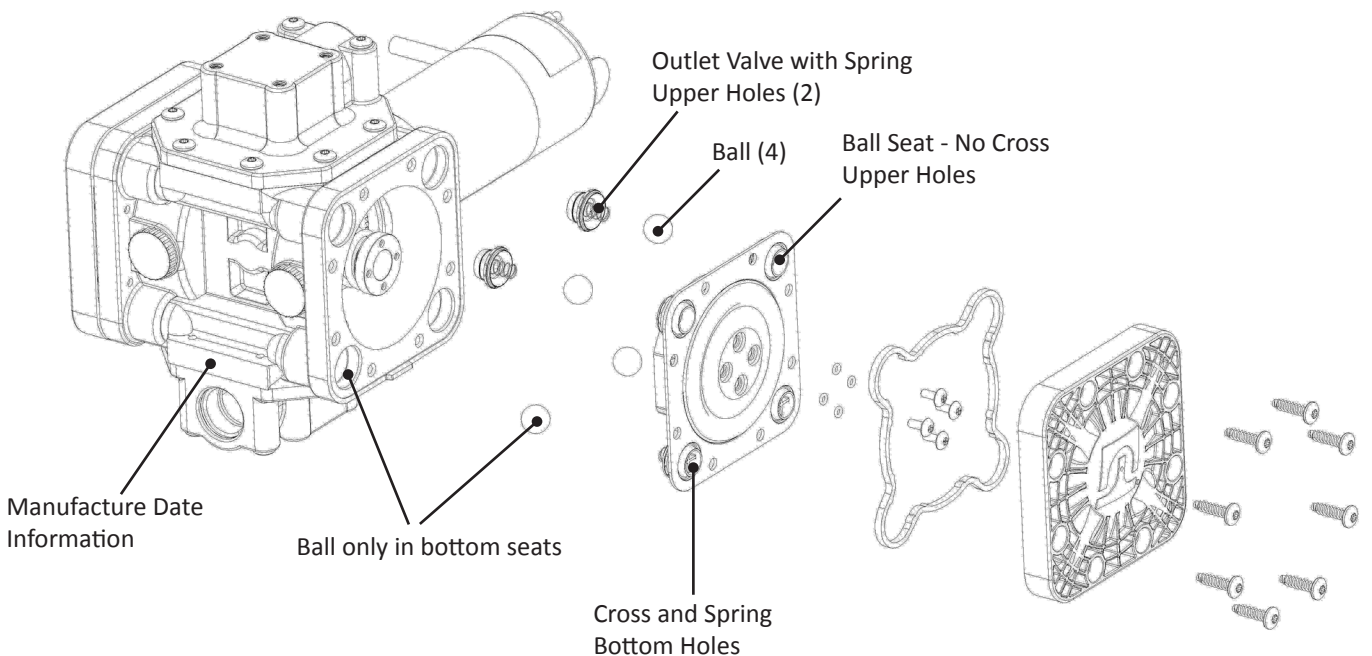

# Model / Accessories / Configuration Information

## Sotera Systems Pumps

Model	Motor	Diaphragms Seals	Inlet	Accessories
SS411BCEXP	12V DC CE Compliant Explosion Proof	Santoprene EPDM	Page 8: Configuration FF	No Accessories
SS413BCEXP	12V DC CE Compliant Explosion Proof	Santoprene EPDM	Page 8: Configuration EE	Pump-N-Go; 2" Female Camlock Coupler w/ 2" Female NPT Threads; 2" x 1" Poly Reducer Bushing; 1" x 39" EPDM Hose; 1" x 12' EPDM Hose; 1" Ball Valve Nozzle; (4) Hose Barbs and Clamps.
SS415B	12V DC	Santoprene EPDM	Page 8: Configuration AA	No Accessories
SS415BX670	12V DC	Santoprene EPDM	Page 8: Configuration AA	No Accessories
SS415BEXP670	12V DC UL Listed Explosion Proof Motor	Santoprene EPDM	Page 8: Configuration EE	No Accessories
SS415BX731	12V DC w/ Bracket	Santoprene EPDM	Page 8: Configuration AA	No Accessories
SS415BX731PG	12V DC w/ Bracket	Santoprene EPDM	Page 8: Configuration AA	Pump-N-Go; 2" Female Camlock Coupler w/ 2" Female NPT Threads; 2" x 1" Poly Reducer Bushing; 1" x 39" EPDM Hose; 1" x 12' EPDM Hose; 1" Ball Valve Nozzle; Poly Telescoping Suction Tube (23" - 40"); (4) Hose Barbs and Clamps.
SS417B	12V DC	Santoprene EPDM	Page 8: Configuration DD	1" x 12' EPDM Hose; 1" Ball Valve Nozzle; Poly Telescoping Suction Tube (23" - 40"); (1) Hose Barbs and Clamps; Cap and Spin On Collar for Bung when Pump has Been Removed.
SS419BX665	12V DC	Hytrell NBR	Page 8: Configuration CC	2" NPT Poly Street Elbow; Monsanto Coupler; 1" x 12' EPDM Hose; 1" Ball Valve Nozzle; Poly Telescoping Suction Tube (23" - 40"); (1) Straight and 1 90° Hose Barb and 2 Clamps; Pump Support Bracket. For Use with Monsanto Tanks.
SS420B	12V DC	Santoprene EPDM	Page 8: Configuration AA	1" x 12' EPDM Hose; 1" Ball Valve Nozzle; Nozzle Hanger on Pump; Poly Telescoping Suction Tube (23" x 40"); (2) 1" Straight Hose Barbs and (1) 90° Hose Barb; (2) Hose Clamps.
SS435B	12V DC	Santoprene EPDM	Pages 7 & 8: Configuration EE	Chemtraveller (Short Frame); 825 Digital Meter; 1" x 9' EPDM Hose; 1" x 12' EPDM Hose; 1" Ball Valve Nozzle; Anti-Drip Tip; 1" Ball Valve; 1" Female Camlock Coupler w/ 1" NPT Male Threads; 1" Poly Short Nipple; (3) 1" Straight Hose Barbs and (1) 90° Hose Barb; 4 Hose Clamps.
SS435BCEXP	12V DC CE Compliant Explosion Proof	Santoprene EPDM	Pages 7 & 8: Configuration EE	Chemtraveller (Short Frame); 825 Digital Meter; 1" x 9' EPDM Hose; 1" x 12' EPDM Hose; 1" Ball Valve Nozzle; Anti-Drip Tip; 1" Ball Valve; 1" Female Camlock Coupler w/ 1" NPT Male Threads; 1" Poly Short Nipple; (3) 1" Straight Hose Barbs and (1) 90° Hose Barb; (4) Hose Clamps.
SS435BX675	12V DC	Santoprene EPDM	Pages 7 & 8: Configuration EE	Chemtraveller (Short Frame); 850 Digital Meter; 1" x 9' EPDM Hose; 1" x 12' EPDM Hose; 1" Ball Valve Nozzle; Anti-Drip Tip; 1" Ball Valve; 2" Female Camlock Coupler w/ 2" NPT Female Threads; 2" x 1" Poly Reducer Bushing; (2) 1" Poly Short Nipples; (4) 1" Hose Barbs; (4) Hose Clamps.
SS435BX700	12V DC	Santoprene EPDM	Pages 7 & 8: Configuration EE	Chemtraveller (Short Frame); 825 Digital Meter; 1" x 9' EPDM Hose; 1" x 12' EPDM Hose; 1" Ball Valve w/ Nozzle and Anti-Drip Tip; 1" Female Camlock w/ 1" NPT Male Threads; 1" Poly Short Nipple; (3) 1" Straight Hose Barbs and (1) 90° Hose Barb; (4) Hose Clamps. Same as SS435B Except All Gaskets and Seals are EPDM.
SS435BX713	12V DC	Santoprene EPDM	Pages 7 & 8: Configuration EE	Chemtraveller (Short Frame); 1" x 9' EPDM Hose; 1" x 12' EPDM Hose; 1" Ball Valve Nozzle; Anti-Drip Tip. Includes all fittings to pump from the top or bottom of a tank or tote.
SS435BEXPX703	12V DC UL Listed Explosion Proof Motor	Santoprene EPDM	Pages 7 & 8: Configuration EE	Chemtraveller (Short Frame); 1" Ball Valve Nozzle; Anti-Drip Tip; (1) 1" Straight Hose Barb; (1) 1" 90° Hose Barb.
SS445B	12V DC	Santoprene EPDM	Page 7: 9" GemCap	Mix-N-Go System; 825 Meter; 1" x 12' EPDM Hose; 1" Ball Valve Nozzle; Poly Telescoping Suction Tube w/ Bellows (28½" x 45½"); Check Valve; (2) 1" Straight Hose Barbs and (1) 90° Hose Barb; (2) Hose Clamps. Recirculation Valve Built In.

## Model / Accessories / Configuration Information (cont'd)

### Sotera Systems Pumps (cont'd)

Model	Motor	Diaphragms Seals	Inlet	Accessories
SS445BX700	12V DC	Santoprene EPDM	Page 7: 9" GemCap	Mix-N-Go System; 825 Meter; 1" x 12' EPDM Hose; 1" Ball Valve Nozzle; Poly Telescoping Suction Tube w/ Bellows (28½" x 45½"); Check Valve; (2) 1" Straight Hose Barbs and (1) 90° Hose Barb; (2) Hose Clamps. Recirculation Valve Built In. Same as SS445B Except All Gaskets and Seals are EPDM.
SS445BX727	12V DC	Santoprene EPDM	Page 7: 9" GemCap	Mix-N-Go System; 825 Meter; 1" x 12' EPDM Hose; 1" Ball Valve Nozzle; Poly Telescoping Suction Tube w/ Bellows (28½" x 45½"); Check Valve; (2) 1" Straight Hose Barbs and (1) 90° Hose Barb; (2) Hose Clamps. Recirculation Valve Built In.
SS460B	115V AC	Santoprene EPDM	Page 8: Configuration AA	1" x 12' EPDM Hose; 1" Ball Valve Nozzle; Nozzle Hanger on Pump; Poly Telescoping Suction Tube (23" x 40"); (2) 1" Straight Hose Barbs and (1) 90° Hose Barb; (2) Hose Clamps.
SS460BX674	115V AC	Santoprene EPDM	Page 8: Configuration EE	1" x 12' EPDM Hose; 1" Ball Valve Nozzle; Nozzle Hanger on Pump; Poly Telescoping Suction Tube (23" x 40"); (2) 1" Straight Hose Barbs and (1) 90° Hose Barb; (2) Hose Clamps.
SS460BX731	115V AC w/ bracket	Santoprene EPDM	Page 8: Configuration CC	1" x 12' EPDM Hose; 1" Ball Valve Nozzle; Nozzle Hanger on Pump; Poly Telescoping Suction Tube (23" x 40"); (2) 1" Straight Hose Barbs and (1) 90° Hose Barb; (2) Hose Clamps.
SS460BX731PG	115V AC w/ bracket	Santoprene EPDM	Page 8: Configuration CC	Pump-N-Go; 2" Female Camlock Coupler w/ 2" Female NPT Threads; 2" x 1" Poly Reducer Bushing; 1" x 39" EPDM Hose; 1" x 12' EPDM Hose; 1" Ball Valve Nozzle; Poly Telescoping Suction Tube (23" - 40"); (4) Hose Barbs and Clamps.
SS465BEXP	115V AC UL Listed Explosion Proof	Santoprene EPDM	Pages 7 & 8: Configuration EE	Chemtraveller (Tall Frame); 825 Digital Meter; 1" x 9' EPDM Hose; 1" x 12' EPDM Hose; 1" Ball Valve Nozzle; Anti-Drip Tip; 1" Ball Valve; 1" Female Camlock Coupler w/ 1" NPT Male Threads; 1" Poly Short Nipple; (3) 1" Straight Hose Barbs and (1) 90° Hose Barb; (4) Hose Clamps.
SS465BX713	115V AC	Santoprene EPDM	Pages 7 & 8: Configuration EE	Chemtraveller (Tall Frame); 1" Ball Valve Nozzle; Anti-Drip Tip; (1) 1" Straight Hose Barb; (1) 1" 90° Hose Barb.

### Fill-Rite Pumps

Model	Motor	Diaphragms Seals	Inlet	Accessories
FR205B	24V DC UL Listed Explosion Proof Motor	Hytrel NBR	Page 8: Configuration AA	No Accessories
FR205BX054	24V DC UL Listed Explosion Proof Motor	Hytrel NBR	Page 8: Configuration BB	No Accessories
FR210B	24V DC UL Listed Explosion Proof Motor	Hytrel NBR	Page 8: Configuration AA	1" x 12' Hose, 1" Manual Nozzle, Telescoping Steel Suction Pipe (23" to 40½").
FR405BEXPX054	12V DC UL Listed Explosion Proof Motor	Hytrel NBR	Page 8: Configuration BB	No Accessories
FR410B	12V DC	Hytrel NBR	Page 8: Configuration AA	1" x 12' Hose, 1" Manual Nozzle, Telescoping Steel Suction Pipe (23" to 40½").
FR410BEXP	12V DC UL Listed Explosion Proof Motor	Hytrel NBR	Page 8: Configuration AA	1" x 12' Hose, 1" Manual Nozzle, Telescoping Steel Suction Pipe (23" to 40½").
FR450B	115V AC	Hytrel NBR	Page 8: Configuration AA	1" x 12' Hose, 1" Manual Nozzle, Telescoping Steel Suction Pipe (23" to 40½").

TROUBLESHOOTING GUIDE		
PROBLEM	POSSIBLE CAUSE	SOLUTION
Pump won't prime	<ul style="list-style-type: none"> <li>• Suction line problem</li> <li>• Leaky check valves</li> <li>• Check valves improperly installed</li> <li>• Outlet plugged</li> <li>• Motor not operating</li> <li>• Stripped or damaged gears</li> </ul>	<ul style="list-style-type: none"> <li>• Check for leaks in suction line.</li> <li>• Check for dirt or damaged check valves and replace.</li> <li>• Check for proper installation. See below.</li> <li>• Check for blockage and clear.</li> <li>• Check power source.</li> <li>• Repair or replace motor.</li> <li>• Check gear assembly and drive gear for damage. Replace complete assembly if necessary.</li> </ul>
Pump hums but will not rotate	<ul style="list-style-type: none"> <li>• Motor faulty</li> <li>• Gear mechanism jammed</li> </ul>	<ul style="list-style-type: none"> <li>• Replace motor.</li> <li>• Check for free rotation of the gears.</li> </ul>
Low pump capacity	<ul style="list-style-type: none"> <li>• Low voltage</li> <li>• Leaky suction line</li> <li>• Dirt in check valve</li> <li>• Faulty check valves</li> <li>• Debris ingested</li> </ul>	<ul style="list-style-type: none"> <li>• Check power source.</li> <li>• Repair leaks.</li> <li>• Dismantle and clean.</li> <li>• Install repair kit.</li> <li>• Add inlet screen.</li> </ul>
Motor overheats	<ul style="list-style-type: none"> <li>• Pumping hot fluids</li> <li>• Motor faulty</li> </ul>	<ul style="list-style-type: none"> <li>• Shorten duty cycle.</li> <li>• Replace motor.</li> </ul>
Fluid Leakage	<ul style="list-style-type: none"> <li>• Faulty or missing gaskets</li> <li>• Loose bolts</li> <li>• Cracked component</li> </ul>	<ul style="list-style-type: none"> <li>• Install all gaskets specified in parts list.</li> <li>• Torque all 1/4" torx head bolts to 75 in lbs.</li> <li>• Torque hex head 1/4-20 motor bolts to 50 in. lbs.</li> <li>• Replace defective component.</li> </ul>

## Regulatory Compliance Information



The "400B CE" series pumps comply with the European Directive 2006/42/EC Machinery Directive. The following standards were used to verify conformance.

EN 809:1998 +A:2009 – Pumps and pump units for liquids – Common safety requirements.

EN ISO 12100:2010 – Safety of Machinery – Basic concepts, general principles for design.

Directive 2014/30/EU – Electromagnetic compatibility.

EN 61000-6-4:2007 / +A1:2011 - General Standard for Industrial Environments

Directive 2011/65/EU – Restrictions of the use of certain hazardous substances in electrical and electronic equipment.



Specific models of the 400 series pumps feature UL / cUL listed electric motors. Check your model versus the **Model / Accessories / Configuration Information** table (pages 11 -12) to determine how your particular pump is equipped.

# **SOTERA**<sup>®</sup> SYSTEMS