

## FR1612 ♦ FR1614 ♦ FR1616

12 VDC Diesel Fuel Transfer Pumps



**FR1612** Figure 1



**FR1614** Figure 2



**FR1616** Figure 3



### DANGER!

- Electrical shock hazard!
- Improper use or installation of this product can cause serious bodily injury or death!
- Electrical wiring should be done by a licensed electrician in compliance with the local, state, and national electrical code, ANSI/NFPA 70, 30, 30A as appropriate.

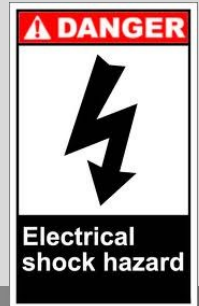

### WARNING!

- NOT FOR USE WITH GASOLINE OR ALCOHOL!
- Not for use in hazardous locations
- Improper use or installation of this product can cause serious bodily injury or death!
- Do NOT smoke near pump or use pump near open flame.
- Do not use this product for fluid transfer into aircraft.
- This product is not suited for use with fluids for human consumption or fluids containing water.
- Do not dispense fluid that is thicker than diesel fuel. Motor may overheat!
- Disconnect power connections PRIOR to replacing fuse!
- Noise emission during bypass mode generates up to 81 dB(A) within one meter distance of the pump.

### SAFETY INSTRUCTIONS!

To ensure safe operation safe and efficient operation, it is essential to read and follow each of these warnings and precautions.

- Disconnect power to pump before servicing.
- A diesel compatible filter should be used on pump outlet to ensure that no foreign material is transferred to the fuel tank.
- The pump power cable is equipped with an electrical fuse. If the fuse burns out switch the pump off, disconnect from power, and look for the cause of the failure. Once the cause of failure has been remedied, replace with a 30 amp fuse.
- Tank or barrel should be anchored to prevent tipping in both the full and empty conditions.
- The pump should never be left unattended while running. Once the nozzle lever is closed, the pump should be shut off immediately.

### General Description

The Tuthill FR1612 is a positive displacement, rotary vane pump. The pump is designed to run on 12VDC power and supply a flow rate of up to 10 GPM (40 LPM) with diesel fuel. The FR1614 &, FR1616 systems consist of the FR1612 pump with accessories.

## MECHANICAL INSTALLATION INSTRUCTIONS

- **DO NOT** install additional foot valves or check valves unless they have a pressure relief valve set at 50 psi or less.
- Use oil resistant pipe sealant or PTFE tape on all pipe threads.

### Model FR1612

1. Select inlet and outlet hoses or pipes compatible with diesel that can withstand at least 50psi. Ports are 3/4" NPT. Tighten fittings securely to a liquid tight seal.
2. Install the strainer provided at the inlet to the suction hose to prevent debris from being drawn into the pump.
3. Use a nozzle or valve at the end of the discharge hose that can be shut off tightly to prevent accidental siphoning when the pump is not in use.

### Model FR1614

1. Install components as shown in Figure 2. Note the direction of flow cast into the front of the pump to determine inlet and outlet.
2. If it is difficult to press the hoses over the barbs, soften the hose by soaking it in hot water for 20 seconds, then slip it over the barbs.
3. Tighten hose clamps securely to provide a liquid tight seal.

### Model FR1616

1. Install components as shown in Figure 3. Note the direction of flow cast into the front of the pump to determine inlet and outlet.
2. If it is difficult to press the hoses over the barbs, soften the hose by soaking it in hot water for 20 seconds, then slip it over the barbs.
3. Tighten hose clamps securely to provide a liquid tight seal. Tighten the suction tube into the pump (use PTFE sealant tape).
4. Extend the poly suction tube to a length that will place it a minimum of 3" from the bottom of the tank or barrel.
5. Thread the poly bung into the opening and tighten securely.

## ELECTRICAL INSTALLATION FOR ALL MODELS

- Connect the battery clips provided to a suitable 12 Volt DC supply capable of delivering the necessary current and voltage.
- The red clip is attached to the positive (+) battery terminal.
- Black clip is attached to the negative (-) battery terminal or the vehicle frame.
- **DO NOT** employ a patch cord to extend the cables. If the cable provided is not long enough, have it replaced by an authorized electrician.
- The pump may be powered by a battery charger of suitable voltage. To prevent possible fire from sparks, never connect the terminals from the battery charger to the pump directly. Always connect the battery clips from the pump to the terminals on the charger.

## OPERATING INSTRUCTIONS

1. Insert nozzle into container to be filled.
2. Switch pump on.
3. Operate nozzle lever to dispense fluid.
4. When the desired amount of fluid has been dispensed, release nozzle lever, remove nozzle from container, and switch pump off.
5. Nozzle should be kept clean and dry, and securely stored when not in use.

## PUMP CHARACTERISTICS

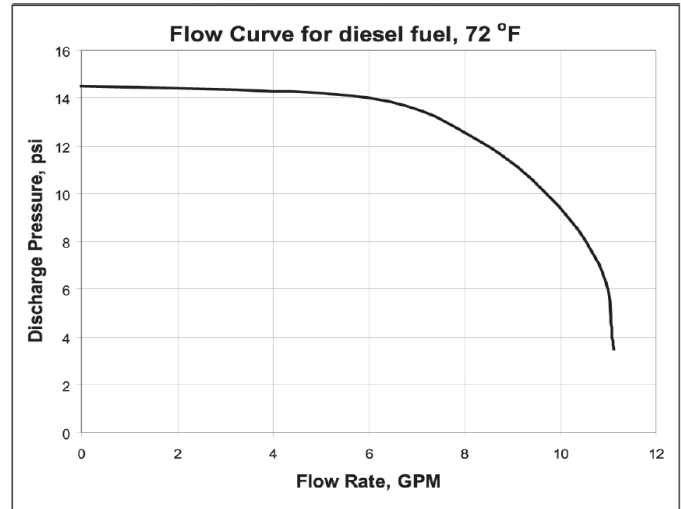

The above flow curve is a guide for pump performance only. Attachment of accessories, changes in fluid pumped, and temperature will affect flow rate delivered.

## TROUBLESHOOTING

### IF PUMP FAILS TO PRIME:

- Check suction line for leaks or obstructions.
- Check bypass valve for dirt. The valve should slide freely.
- Check electrical connections; the pump will run backwards if the red and black wires are reversed.
- Open nozzle to allow air to be removed from the system.

### PUMP IS BOUND:

If the motor hums but the pump does not start, the possible cause is a stuck rotor. Remove rotor cover and check rotor and vanes for dirt.

### LOW PUMPING CAPACITY:

- Strainer screen clogged (strainer screen is in top of poly suction tube).
- Bypass valve not seating properly (1).
- Obstruction in suction line.
- Make sure all five vanes slide easily in their slots (2).

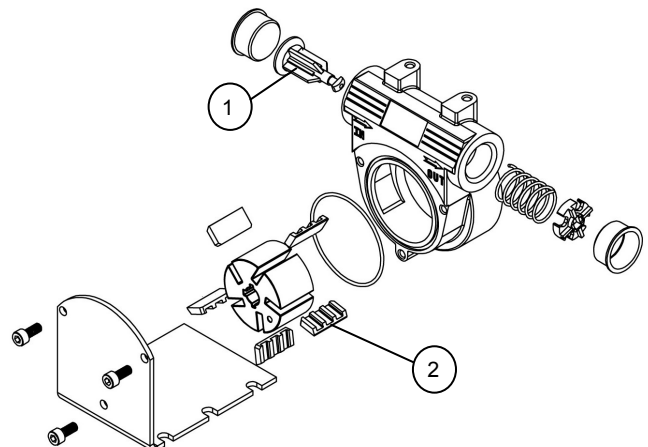

## PARTS LIST

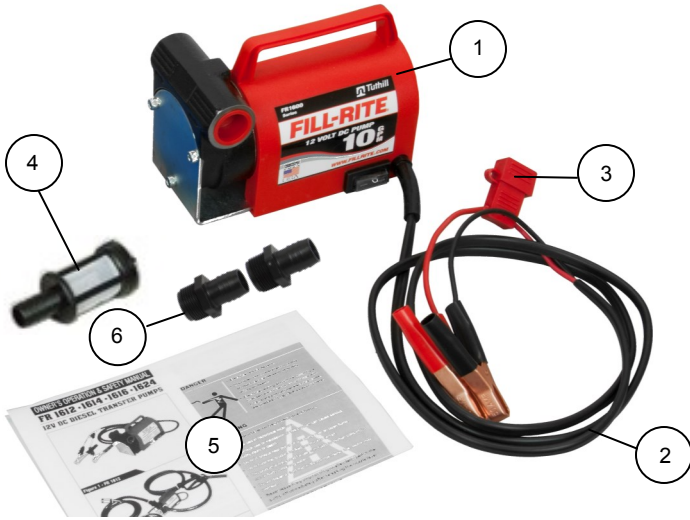

### FR1612

#	Description	Qty.
1	FR1612 Pump	1
2	6.5' Electrical Cable with Battery Clips	1
3	30 Amp Fuse	1
4	End of Hose strainer (3/4")	1
5	Owners Manual	1
6	3/4 NPT x 3/4" Barb Fitting	2

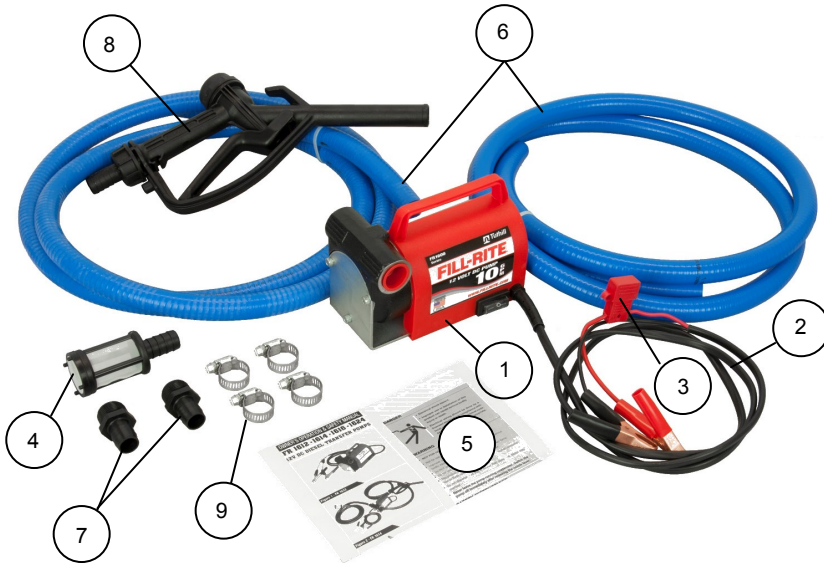

### FR1614

#	Description	Qty.
1	FR1612 Pump	1
2	6.5' Electrical Cable with Battery Clips	1
3	30 Amp Fuse	1
4	End of Hose strainer (3/4")	1
5	Owners Manual	1
6	8' x 3/4" PVC Hose	2
7	3/4 NPT x 3/4" Barb Fitting	2
8	Polypropylene Nozzle w/Integral Swivel	1
9	Hose Clamp	4

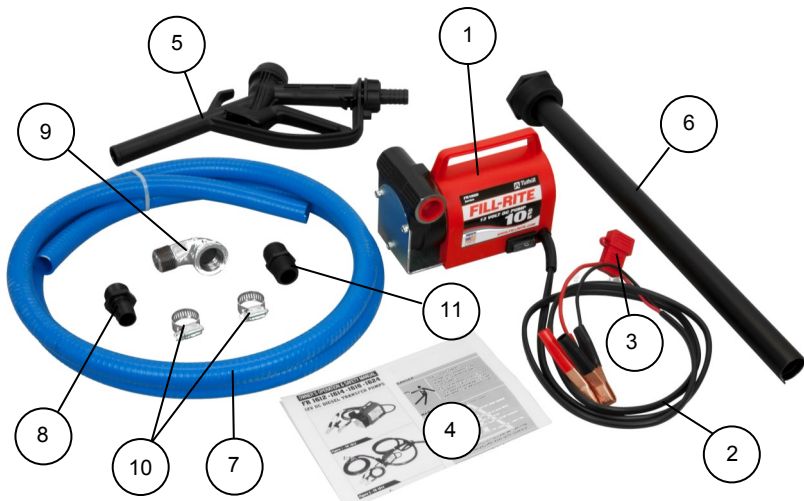

### FR1616

#	Description	Qty.
1	FR1612 Pump	1
2	6.5' Electrical Cable with Battery Clips	1
3	30 Amp Fuse	1
4	Owners Manual	1
5	Polypropylene Nozzle w/Integral Swivel	1
6	Extendable Polypropylene Suction Pipe	1
7	8' x 3/4" PVC Hose	1
8	3/4 NPT x 3/4" Barb Fitting	1
9	3/4 NPT x 3/4" Elbow	1
10	Hose Clamp	2
11	3/4" NPT Pump to Suction Pipe Fitting	1

## PRODUCT SPECIFICATIONS

Model Number	FR1612	FR1614	FR1616
Description	12 VDC rotary vane pump only and strainer	12VDC rotary vane pump with hoses, nozzle, strainer, clamps, barbed inlet and outlet adapters.	12VDC rotary vane pump with hose, nozzle, adjustable poly suction pipe, strainer, clamps, barbed outlet adapter.
Warranty	1 Year	1 Year	1 Year
Construction—Pump Housing	Cast Iron	Cast Iron	Cast Iron
Maximum flow rate (with factory supplied hose & nozzle)	Up to 10 GPM	Up to 10 GPM	Up to 10 GPM
Rotor Composition	Iron	Iron	Iron
Motor Horsepower	1/5 HP	1/5 HP	1/5 HP
Amp Draw	17Amp	17 Amp	17 Amp
RPM	3800	3800	3800
Voltage	12 VDC	12 VDC	12 VDC
Fuse in power cable	30 Amp	30 Amp	30 Amp
Inlet	3/4" NPT	3/4" NPT	3/4" NPT
Outlet	3/4" NPT	3/4" NPT	3/4" NPT
Vane Material	Acetal	Acetal	Acetal
Duty Cycle	30 Minutes	30 Minutes	30 Minutes
Internal Bypass valve	Yes	Yes	Yes
Seal Material (Rotor Cover Seal / Shaft Seal)	NBR / HNBR	NBR / HNBR	NBR / HNBR
<b>Box Contents</b>			
Nozzle	No	Yes	Yes
Hoses	No	Yes	Yes
Poly Suction Tube	No	No	Yes (3/4" NPT)
Strainer for Inlet	Yes	Yes	Yes
Power Cable	6.5' cable with fuse and battery clips.	6.5' cable with fuse and battery clips.	6.5' cable with fuse and battery clips.



The FR1600 series pump has been tested and complies with the European Community Directive 2006/42/EC, Directive on Machinery. The following standards were used to verify conformance.

EN 809 "Pumps and pump units for liquids – Common safety requirements"

EN ISO 12100 "Safety of Machinery – Basic concepts, general principles for design"

2014/30/EU "Electromagnetic compatibility"

2011/65/EU "Restrictions of the use of certain hazardous substances in electrical and electronic equipment"