

# FILL-RITE®

## SERIES 5200 PISTON HAND PUMP

### Owner's Operation & Safety Manual

Models FR150, FR151, FR152, FR156

#### SAFETY INSTRUCTIONS

To ensure safe and efficient operation, it is essential to read and follow each of these warnings and precautions.

1. **Improper use or installation of this product can cause serious bodily injury or death.**
2. Do NOT smoke near pump or use pump near an open flame when pumping flammable fluids. Fire could result.
3. A Fill-Rite filter should be used on pump outlet to ensure that no foreign material is transferred to fuel tank.
4. Use gasoline and oil resistant thread sealant or sealant tape on all threaded joints to protect against leakage.
5. Storage tank or barrel should be anchored to prevent tipping in both the full and empty conditions.
6. To minimize static electricity build-up, keep nozzle in contact with container being filled.

#### WARNING

This product should not be used for fluid transfer into aircraft. This product is not suited for use with fluids for human consumption or fluids containing water.

#### Fluid Compatibility

If in doubt about compatibility of a specific fluid, contact supplier of fluid to check for any adverse reactions to the wetted materials.

The 5200 is compatible with the following fluids:

- Gasoline, Diesel, Heptane, Kerosene, Stoddard Solvent, Light Oils, Mineral Spirits

Do NOT use the 5200 with the following fluids:

- Water, Sulfuric Acid, Naptha, Methanol, Methyl Ethyl Ketone (MEK), Acetone, Ammonia, Benzene, Bleach, Chlorine

#### SAFETY APPROVAL



#### INSTALLATION

**NOTE:** All pipe threads must have a sealant to protect against leaks. Use sealant tape provided with the pump, or use a gasoline and oil resistant thread sealant.

1. Screw suction pipe into pump inlet flange and tighten.
2. Extend suction pipe into tank or barrel opening to within 3" of bottom of tank or barrel. Do not rest suction pipe on bottom.
3. Screw inlet flange of pump completely and securely into undamaged tank or barrel bung.

#### PUMPS WITH HOSE AND NOZZLE

4. Screw one end of hose into pump discharge opening and the nozzle to other end of hose.

#### PUMPS WITH DISCHARGE SPOUTS

4. Screw discharge spout assembly into top of pump.

#### PUMPS WITH METER, HOSE AND NOZZLE

4. Screw street elbow into top of pump, nipple into street elbow, meter onto nipple. Note: Position the meter to the right of the handle facing operator for ease of operator viewing. Screw one end of hose into meter outlet and the nozzle to the other end of hose.

#### PUMP FLOW REVERSAL INSTRUCTIONS

Rotating the piston 180° inside the pump will reverse the flow of the pump.

**NOTE:** Removing the piston is not required to complete this process.

1. Remove the linkage pin (item 14) that retains the links (item 13) on the piston (item 3).
2. Using a wrench, rotate the piston 180°. Take care to avoid scratching the piston shaft.
3. Reattach the links (item 13) using the removed linkage pin (item 14).
4. Remove the Anti-Siphon Valve (item 25) and replace with 3/4" NPT pipe plug.

#### OPERATING INSTRUCTIONS

1. Reset meter to 0 (if applicable).
2. Insert nozzle into tank (if applicable).
3. Operate handle to begin fluid flow.
4. When finished pumping, allow hose to drain and return nozzle to nozzle boot.

#### TROUBLESHOOTING

**IF PUMP FAILS TO PRIME:** Check suction line for leaks or obstructions. Check valves and piston for nicks, burrs or wear. Check gasket for leakage.

**LOW PUMPING CAPACITY:** Remove and clean screen. Check for leaks in suction line.

**PUMP FLUID LEAKAGE:** Tighten bearing nut 1/4 to 1/2 turn. Replace packing. Replace anti-siphon valve. Tighten covers and joints.

## 5200 SERIES PUMP PARTS LIST

ITEM NO.	PART NUMBER	DESCRIPTION	QTY.
1	5200F1332	BODY, PISTON HAND PUMP, MACH.	1
2	5200f1230	PISTON, PISTON HAND PUMP, MACH.	1
3	5200F1260	PISTON RING, PISTON HAND PUMP	2
4	100F0801	GASKET, LATHE CUT NITRILE	1
5	5200F1420	LINER, PISTON HAND PUMP	1
6	5200F1300	COVER, PISTON HAND PUMP	1
7	304F7904	1/4-20 HWHTFS	8
8	5200F1869	VACUUM BREAKER	1
9	5200F1310	PACKING RING, PISTON HAND PUMP	1
10	5200F1331	BEARING NUT, PISTON HAND PUMP	1
11	5200G9351	INLET SCREEN, PISTON HAND PUMP	1
12	5200F1340	CLEVIS LINK, PISTON HAND PUMP	2
13	5200f1460	LOCKING LINK, PISTON HAND PUMP	1
14	5200F1350	CLEVIS PIN, PISTON HAND PUMP	3
15	702F3579	HITCH PIN CLIP, #13	3
16	5200F1410	RIVET, 1/4X5/8"	1
17	5200G8869	O-RING, NITRILE-045	2
18	5200F1440	SPRING WASHER	1
19	5200F1790	NOZZLE, MACHINED	1
20	5200F1839	SUCTION TUBE ASSEMBLY	1
21	SA001030-001	HOSE ASSEMBLY, 5/8" X 8' UL LISTED: TTS	1
22	100F0652	LABEL, LOGO	1
23	5200F1262	VALVE ASSEMBLY, PISTON HAND PUMP	4
24	5200F1376	Assembly Template	1
25	5200F1619	Assembly Template	1

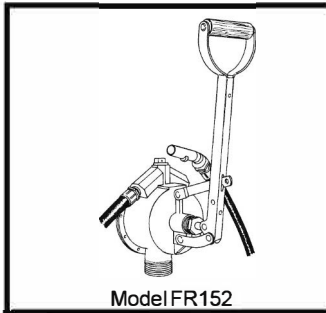
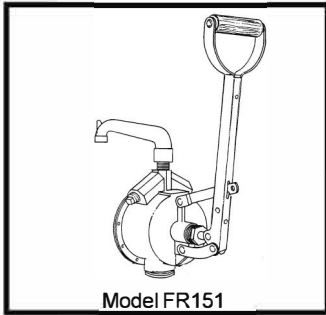

5200KTF1828	Repair Kit (Includes items 3, 4, 8, 9, 10, 11, 17, 23)
-------------	--

807CMK	Gallon Meter Kit
807CLMK	Liter Meter Kit

F1810PM0	Particulate Filter Kit
F1810HM0	Hydrosorb (Water) Filter Kit
1200KTG9075	Filter Head

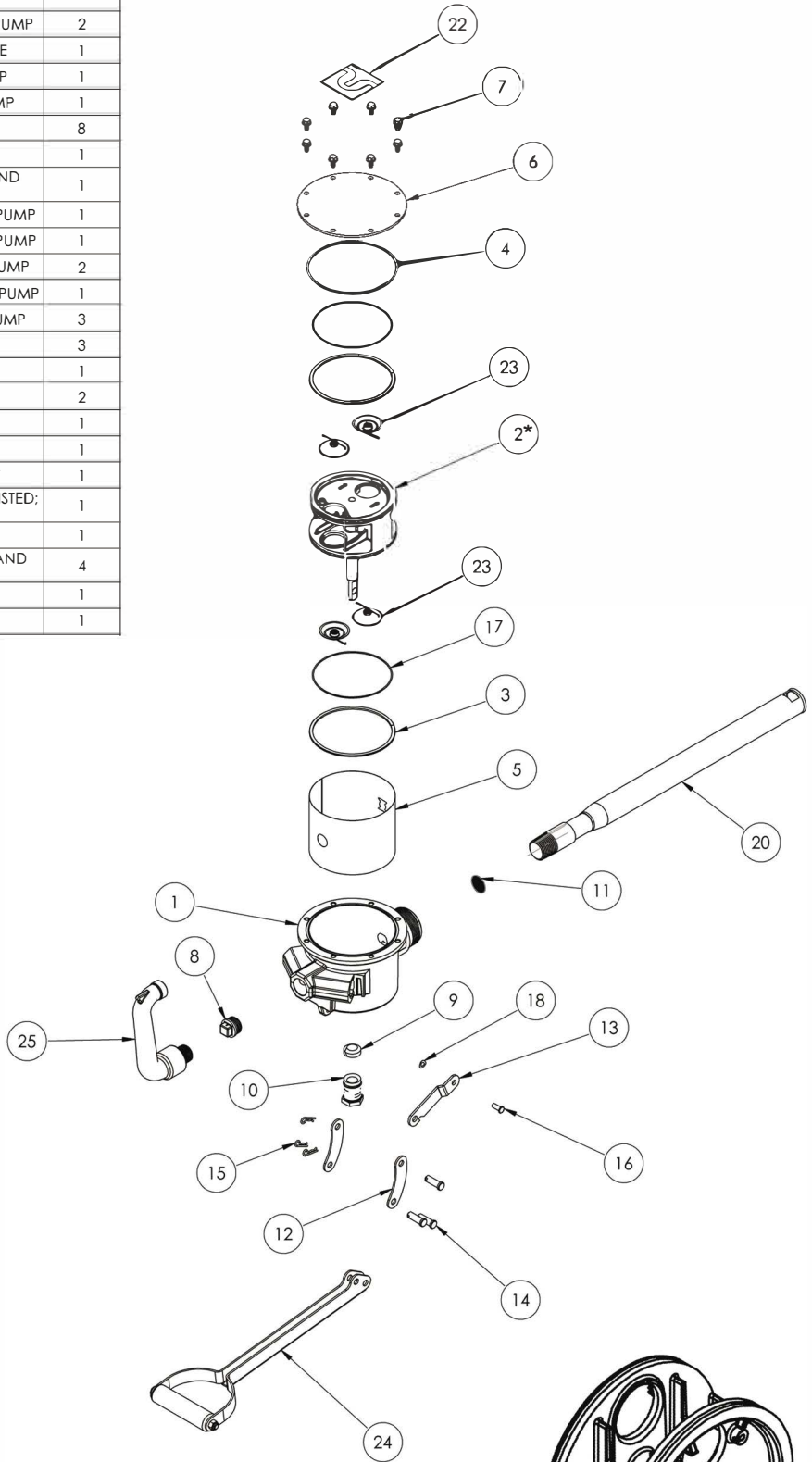

**\*NOTE:** Arrows on piston must point to inlet (down) when installed. Pump will not function correctly if not installed properly.



Excellence at work. Excellence in life.