

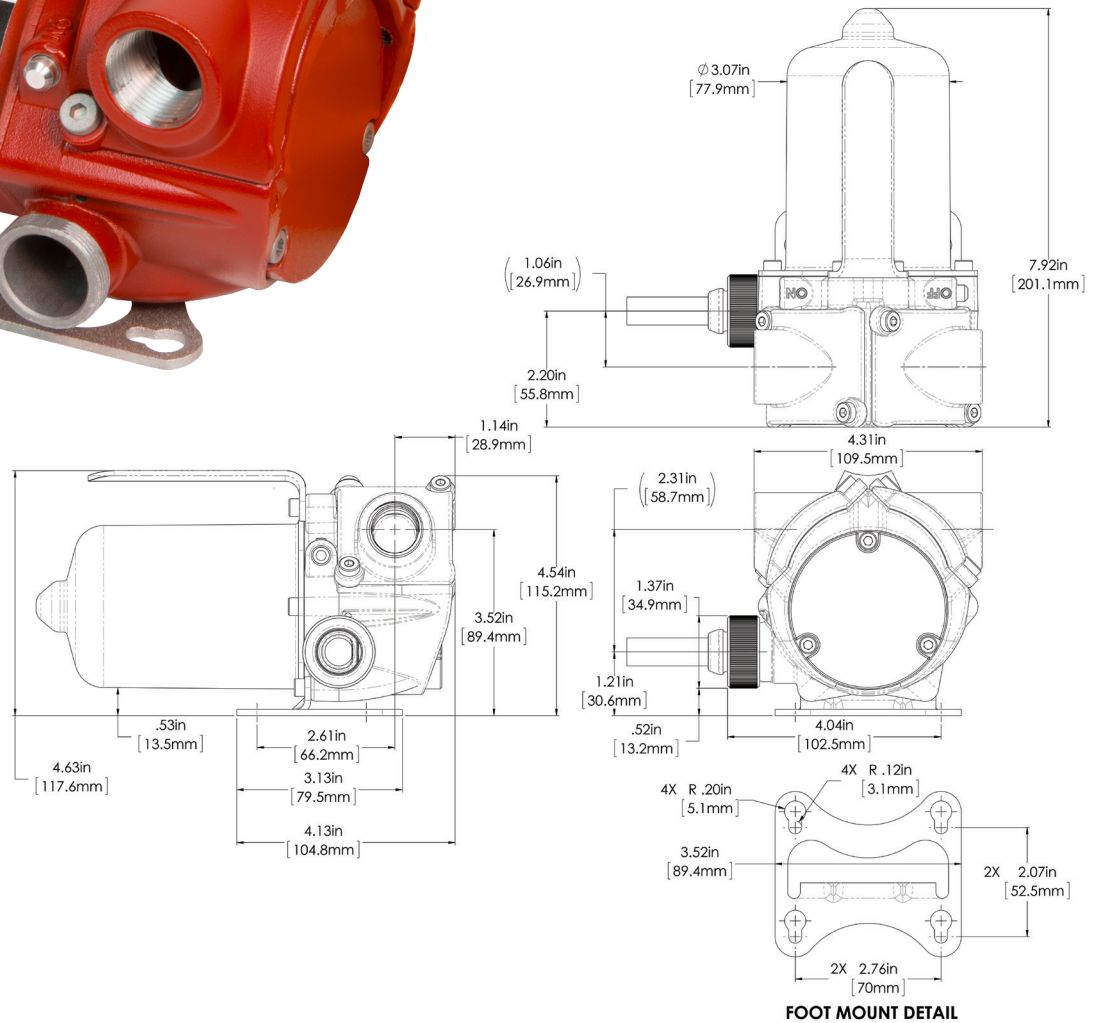

RD Series Technical Specifications



Pump

Type - Rotary, Diaphragm, Gear, Vane	Rotary Hinged Vane
Flow Rate in Supplied Configuration	Up to 8 GPM / 30 LPM
Flow Rate Open Flow - no Hose or Nozzle	Up to 10.2
Max Discharge Pressure (PSI)	16 PSI
Dry Vac (in Hg)	5 in Hg
Head - Max (Ft.)	37'
Anti-Siphon Valve	None
Inlet - Size / Thread	3/4" NPT
Outlet - Size / Thread	3/4" NPT
Material - Pump Housing	Aluminum
Material - Wetted Material	BUNA - N + HNBR
Rotor Material of Construction	Nylon
Rotor Vane Material of Construction	Acetal
Compatible Fluids	Diesel, Gasoline, BioDiesel up to B20, E15, Kerosene, Mineral Spirits, Methanol (up to 15%)
Strainer Mesh Size	20 X 20
Warranty	2 Years

Motor

Power - DC 12, 24, 12/24	12 VDC
HP (Horsepower) Rating	1/6 HP
Power Cord Length (feet)	10'
Power Cord Gauge (AWG)	14 AWG
DC Power Cord Connectors	Yes
Amps (FLA)	14 A
RPM	3600
Duty Cycle	30 min. ON / 30 min. OFF
Thermal Protection Switch	Yes
Circuit Protection Fuse	Yes (30 Amp Fuse)
Certification	UL/cUL Motor

RD8 SERIES PERFORMANCE CURVE

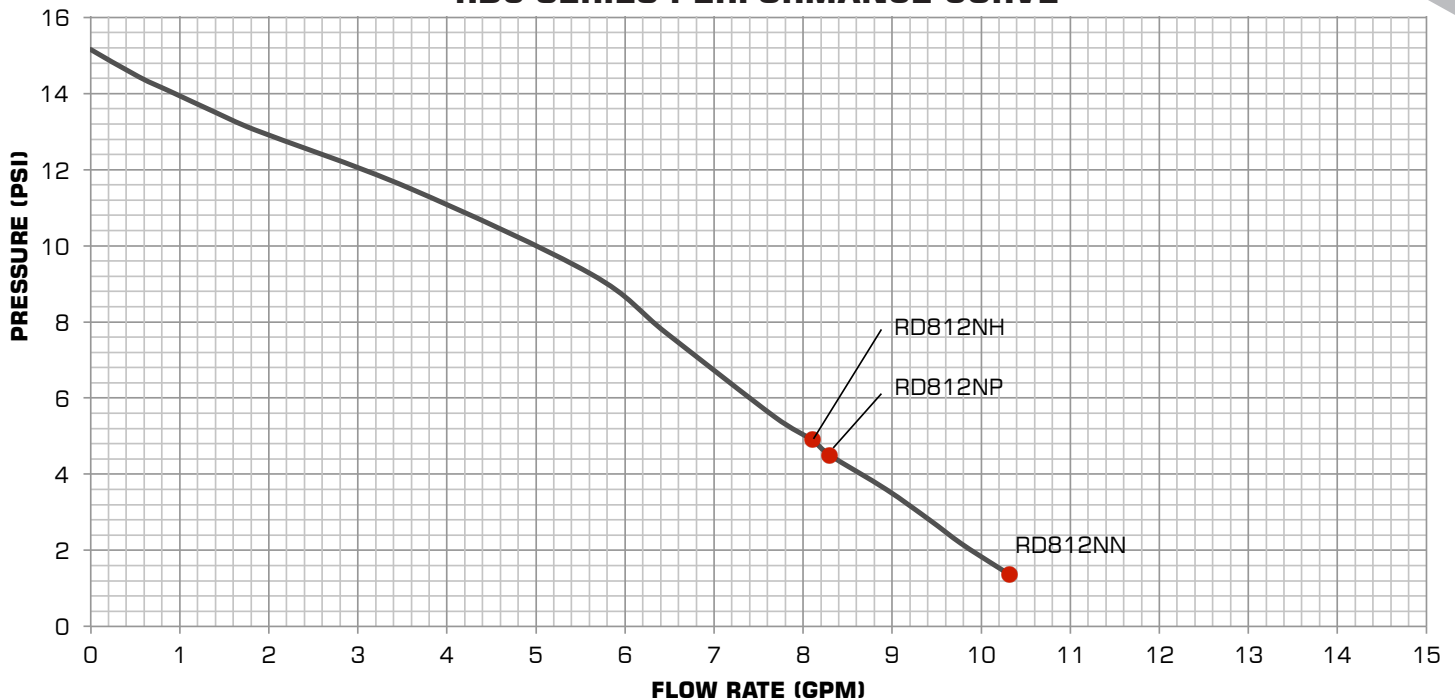

AVAILABLE MODELS

Model #	Includes
RD812NN	10' Quick connect power cord with battery clips
RD812NH	Manual nozzle, 8' Discharge hose, 6' Suction hose, and a 10' Quick connect power cord with battery clips
RD812NP	Manual nozzle, 8' Discharge hose, 23"-41" Telescoping suction tube, Nozzle boot, Bung tank mount adapter, 10' Quick connect power cord with battery clips

Accessories

Suction pipe material	Composite
Suction pipe length - not extended/extended	23" / 41"
Nozzle - size and type	3/4" Manual
Hose liquid materials compatibility	Gasoline, Diesel, E15, BioDiesel up to B20, Kerosene, Methanol (up to 15%), Mineral Spirits
Suction hose and discharge hose diameter	3/4" - 5/8"
Hose length	8' Discharge Hose 6' Suction Hose

SERVICE KIT INFORMATION

Kit	Description	Parts
KIT812NP	Bung Mount Kit	Nozzle Boot, 2 Screws, 2 Hex Nuts, Bung Adapter, 23-41" Suction Tube, Pipe Nipple, Teflon Tape
KIT812RG	Rebuild Kit	Rotor Cover, Rotor O-Ring, 3 Rotor Screws, 5 Vanes, Hinged Vane Rotor, Inlet Screen, 2 Flange O-Rings, 4 Flange Screws
KIT812SL	Seal Kit	1 Rotor O-Ring, 3 Rotor Screws, Inlet Screen, 2 Flange O-Rings, 4 Flange Screws
KIT812FL	Flange Kit	Flange, Flange O-Ring, Inlet Screen, 2 Flange Fasteners
KIT812NH	Hose Kit	8' Discharge Hose, and 6' Suction Hose
KIT812PC	Power Cable Kit	10' Quick Connect Power Cord with Battery Clips

Logistics

RD812NN	UPC	89404224687
	Shipping Weight	9.4 lbs.
	Length	9"
	Width	9"
	Height	7.25"
RD812NH	UPC	89404224694
	Shipping Weight	14.23 lbs.
	Length	18"
	Width	18"
	Height	7.25"
RD812NP	UPC	89404224700
	Shipping Weight	15.59 lbs.
	Length	18"
	Width	18"
	Height	7.25"