



## Model EHC.230/3

Portable Metal Cutting Circular Saw

# OPERATOR'S MANUAL

 **WARNING!**

TO REDUCE THE RISK OF INJURY, USER MUST READ AND UNDERSTAND INSTRUCTION MANUAL.



EYE PROTECTION  
REQUIRED



HEARING PROTECTION  
REQUIRED



NEVER PLACE  
FINGERS NEAR  
CUTTING AREA.  
BEWARE OF  
ROTATING  
MACHINE PARTS



LINE VOLTAGE  
PRESENT

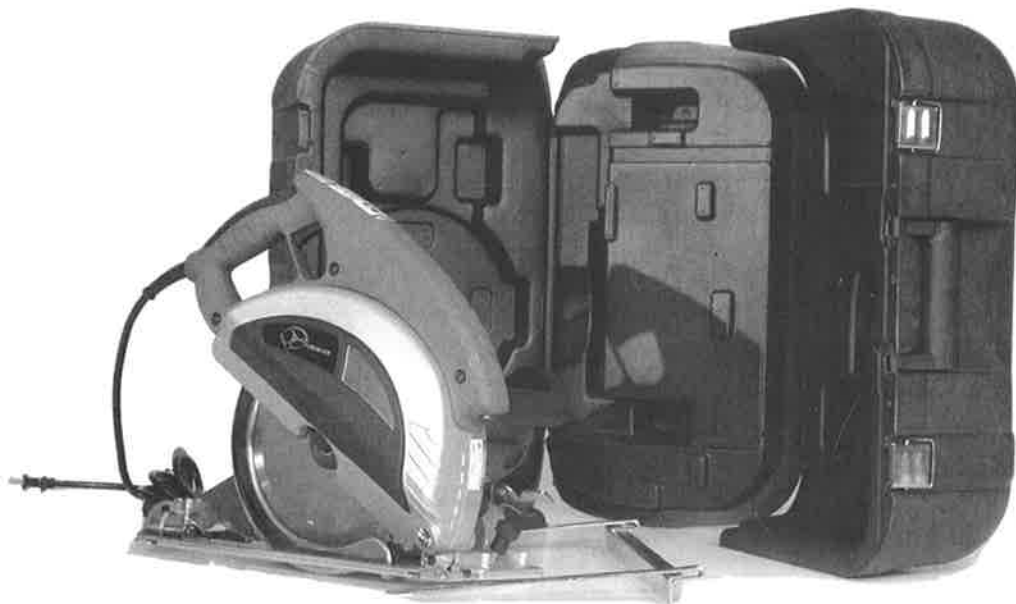

MODEL EHC.230/3 (220V-240V/50Hz)

Serial # \_\_\_\_\_

Date of Purchase \_\_\_\_\_

## GENERAL SAFETY RULES

### **WARNING! Read and Understand all Instructions.**

Failure to follow all instructions listed below, may result in electric shock, fire and/or serious personal injury.

#### **SAVE THESE INSTRUCTIONS**

#### **Work Area**

- *Keep Your Work Area Clean and Well Lit.*
- **Cluttered benches and dark areas invite accidents.**
  
- *Do not operate power tools in explosive atmospheres, such as in the presence of flammable liquids, gases, or dust. Power tools create sparks which may ignite the dust or fumes.*
  
- *Keep bystanders, children, and visitors away while operating a power tool. Distractions can cause you to lose control.*

#### **Electrical Safety**

- *Grounded tools must be plugged into an outlet properly installed and grounded in accordance with all codes and ordinances. Never remove the grounding prong or modify the plug in any way. Do not use any adapter plugs. Check with a qualified electrician if you are in doubt as to whether the outlet is properly grounded. If the tools should electrically malfunction or break down, grounding provides a low resistance path to carry electricity away from the user.*
  
- *Avoid body contact with grounded surfaces such as pipes, radiators, ranges and refrigerators. There is an increased risk of electric shock if your body is grounded.*
  
- *Don't expose power tools to rain or wet conditions. Water entering a power tool will increase the risk of electric shock.*
  
- *Do not abuse the cord. Never use the cord to carry the tools or pull the plug from an outlet. Keep cord away from heat, oil, sharp edges or moving parts. Replace damaged cords immediately. Damaged cords increase the risk of electric shock.*
  
- *When operating a power tool outside, use an outdoor extension cord marked "W-A" or "W." These cords are rated for outdoor use and reduce the risk of electric shock.*

(Note) When using an extension cord, be sure to use one heavy enough to carry the current your product will draw. An undersized cord will cause a drop in line voltage resulting in loss of power and overheating. The recommended minimum is a 12 gauge extension cord not exceeding 50 feet.

# SPECIFIC SAFETY RULES AND SYMBOLS

## WARNING!

DO NOT OPERATE MACHINE IF WARNING AND/OR INSTRUCTION LABELS ARE MISSING OR DAMAGED.  
CONTACT ROCKIES GLOBAL MARKETING FOR REPLACEMENT LABELS.



Symbol	Description
V .....	volts
A .....	amperes
Hz .....	hertz
min .....	minutes
~ .....	alternating current
$n_0$ .....	no load speed
 .....	Double Insulated

1. Only use EUROBOOR BV approved saw blades. Unauthorized blades may be dangerous!
2. Keep saw blades securely fastened. Check blade flanges for debris before installing any new blade.
3. Do not use dull or broken blades. Check blades often for condition and wear.
4. Check chip collector cover for proper fit to minimize the risk of flying debris.
5. Beware of ejecting chips. They become HOT both during and after cutting.
6. Always make provisions for safe handling of excess material.
7. Keep bottom of base plate free from dirt and other debris.

## SPECIFIC SAFETY RULES (continued)

### LASER ALIGNMENT GUIDE PRECAUTIONS



#### **DANGER!**

**LASER RADIATION. AVOID DIRECT EYE EXPOSURE. DO NOT STARE INTO THE LASER LIGHT SOURCE.**  
Never aim light at another person or object other than the workpiece. Laser light can damage your eyes.



Avoid Exposure - Laser Radiation is emitted from this aperture.



#### **WARNING!**

**DO NOT USE TINTED GLASSES TO ENHANCE THE LASER LIGHT.** Tinted glasses will reduce overall vision for the application and interfere with the normal operation of the tool.



#### **WARNING!**

**NEVER AIM THE BEAM AT A WORKPIECE WITH A REFLECTIVE SURFACE.** Highly polished or similar reflective surfaces are not recommended for laser use where eye exposure is possible due to reflection. These surfaces could reflect the beam back toward the operator or bystanders.

**ALWAYS CONSIDER THE PATH OF POSSIBLE BEAM DEFLECTION.**

# FUNCTIONAL DRAWINGS

 **Caution!** Always unplug saw before changing blades, servicing or adjusting saw.

## RIGHT SIDE VIEW

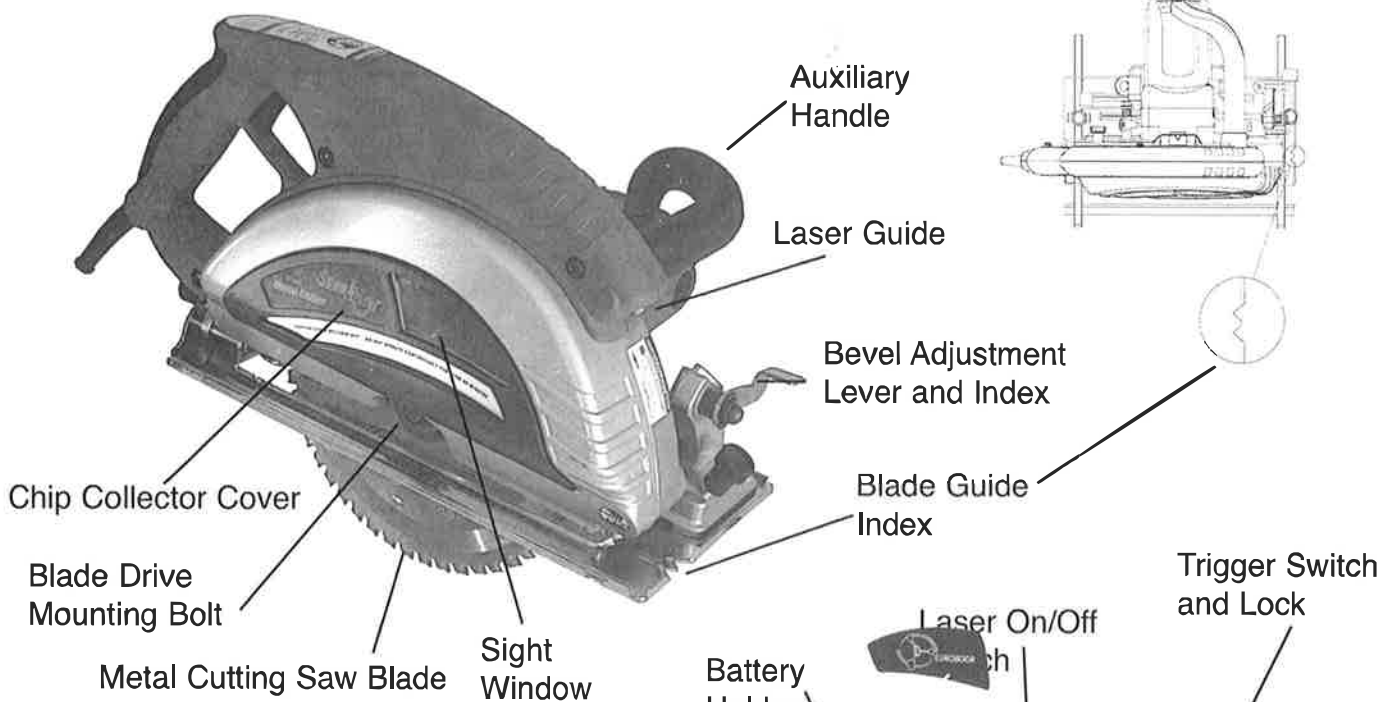

## LEFT SIDE VIEW

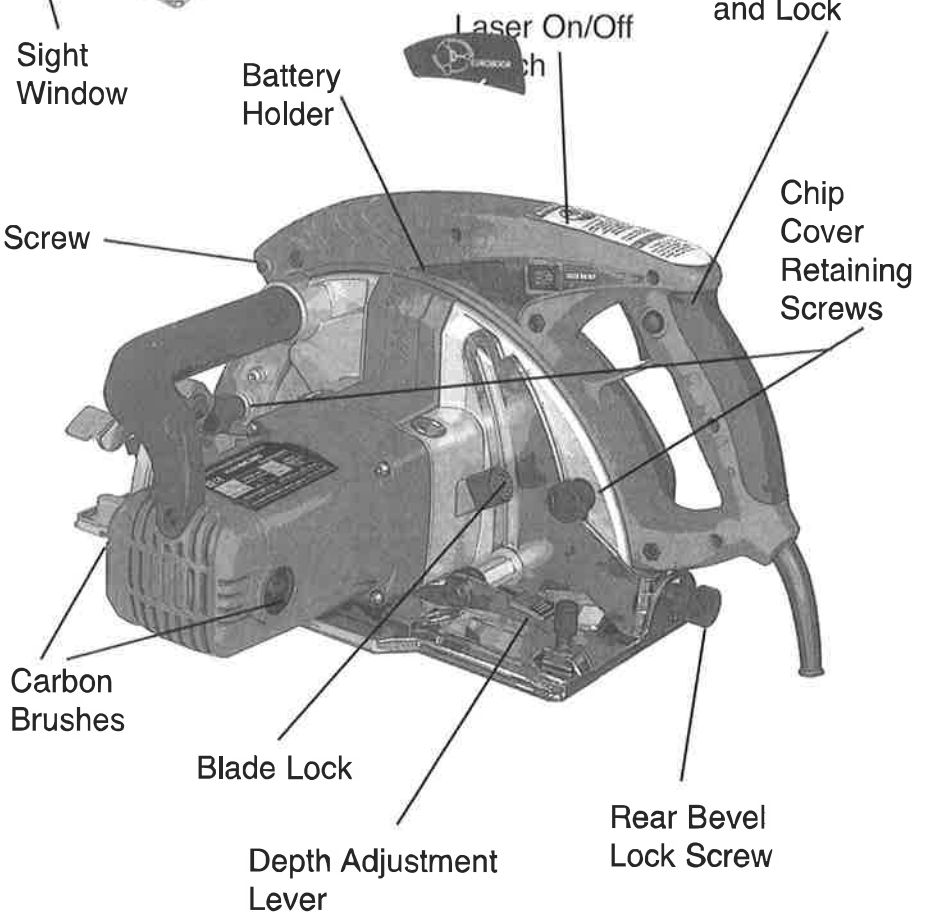

# PARTS LIST

ITEM	DESCRIPTION	PART #	QTY	ITEM	DESCRIPTION	PART #	QTY
1	PLASTIC TRIM COVER	SM-1	1	55	BEARING	SM-55	1
2	SIGHT WINDOW	SM-2	1	56	HANDLE, LEFT SIDE TRIGGER	SM-56	1
3	CHIP COLLECTOR COVER	SM-3	1	57	NUT, HANDLE RETAINING	SM-57	3
4	TRIM COVER SCREWS	SM-4	2	58	HANDLE, SOFT GRIP	SM-58	1
5	INNER CHIP COVER PLATE	SM-5	1	59	POWER CORD	SM-59	1
6	WASHER	SM-6	4	60	STRAIN RELIEF, CORD	SM-60	1
7	SCREW	SM-7	4	61	CLIP, STRAIN RELIEF	SM-61	1
8	BOLT, BLADE DRIVE MOUNTING	SM-8	1	62	SCREW	SM-62	2
9	WASHER, OUTER BLADE DRIVE	SM-9	1	63	TRIGGER SWITCH	SM-63	1
10	FLANGE, OUTER BLADE DRIVE	SM-10	1	64	LASER SWITCH	SM-64	1
11	SAW BLADE	230.0003	1	65	BEZEL, LASER SWITCH	SM-65	1
12	FLANGE, INNER BLADE DRIVE	SM-12	1	66	OVERLOAD (SOME MODELS)	SM-66	1
13	RETAINER, MOVEABLE GUARD	SM-13	1	67	HOLDER, LASER DIODE	SM-67	1
14	BLADE GUARD	SM-14	1	68	LASER DIODE	SM-68	1
15	SCREW	SM-15	2	69	SPRING, LASER ADJUSTING	SM-69	1
16	SPRING, BLADE GUARD RETURN	SM-16	1	70	HANDLE, RIGHT SIDE TRIGGER	SM-70	1
17	FIXED GUARD	SM-17	1	71	WASHER	SM-71	3
18	CHIP DEFLECTOR BRACKET	SM-18	1	72	SCREW	SM-72	3
19	BLADE GUARD BUMPER	SM-19	1	73	THUMBSCREW, EDGE GUIDE/BEVEL LOCK	SM-73	3
20	CLIP, THUMBSCREW RETAINING	SM-20	2	74	WASHER	SM-74	2
21	MAIN FRAME	SM-21	1	75	SPRING	SM-75	1
22	THUMBSCREW, CHIP COVER RETAINING	SM-22	2	76	CLIP	SM-76	1
23	PLASTIC BATTERY COVER, OUTER	SM-23	1	77	SHOE PLATE (REPLACED AS ASSEMBLY)	SM-77	1
24	BATTERY HOLDER	SM-24	1	78	BUSHING (PART OF ASSEMBLY #77)	SM-78	1
25	BATTERY HOLDER SUPPORT	SM-25	1	79	EDGE GUIDE	SM-79	1
26				80	RIVET (PART OF ASSEMBLY #77)	SM-80	1
27				81	RETAINER, EDGE GUIDE	SM-81	1
28	BATTERY, AAA TYPE	SM-28	2	82	SCREW	SM-82	3
29	BATTERY COVER	SM-29	1	83	PIN, SHOE PLATE FRONT	SM-83	1
30	PLATE, GEARBOX COVER	SM-30	1	84	THUMBSCREW	SM-84	1
31	BEARING, BALL	SM-31	1	85	WRENCH, BLADE	SM-85	1
32	BEARING, BALL	SM-32	1	86			
33	COUNTER-SHAFT	SM-33	1	87			
34	KEY	SM-34	1	88	BOLT	SM-88	1
35	GEAR	SM-35	1	89	BRACKET, MOVABLE BEVEL	SM-89	1
36	RETAINER CLIP	SM-36	1	90	BRACKET, STATIONARY BEVEL	SM-90	1
37	BUSHING	SM-37	1	91	WASHER	SM-91	1
38	GEAR HOUSING	SM-38	1	92	SPRING	SM-92	1
39	SPRING, BLADE LOCK	SM-39	1	93	LEVER, BEVEL LOCK	SM-93	1
40	BLADE LOCK	SM-40	1	94	CLIP, RETAINING	SM-94	1
41	SCREW, AUXILIARY HANDLE	SM-41	1	95	NUT, BEVEL LOCK	SM-95	1
42	AUXILIARY HANDLE	SM-42	1	96	SCREW, BLADE GUARD SPRING	SM-96	1
43	SCREW	SM-43	4	97	BOLT, DEPTH ADJUSTING	SM-97	1
44	WASHER	SM-44	4	98	SCREW, GEARBOX COVER	SM-98	3
45	CARBON BRUSH HOLDER	SM-45	2	99	SCREW, LASER ADJUSTING	SM-99	1
46	CARBON BRUSH	SM-46	2	100	BRACKET, REAR DEPTH ADJUST	SM-100	1
47	CARBON BRUSH COVER	SM-47	2	101	CONNECTING ROD	SM-101	1
48	MOTOR HOUSING	SM-48	1	102	BOLT, DEPTH ADJUST	SM-102	1
49	BUSHING, BEARING HOLDER	SM-49	1	103	WASHER	SM-103	1
50	FIELD WINDING	SM-50	1	104	GEAR, OUTPUT SHAFT	SM-104	1
51	SCREWS, FIELD WINDING	SM-51	2	105	KEY	SM-105	1
52	FAN SHROUD	SM-52	1	106	OUTPUT SHAFT	SM-106	1
53	BEARING	SM-53	1	107	RETAINING CLIP	SM-107	1
54	ARMATURE	SM-54	1				

## OPERATION

### WHAT YOU SHOULD KNOW BEFORE SAWING

#### WARNING!

NEVER START THE SAW WITH CUTTING EDGE OF SAW BLADE CONTACTING WORK SURFACE. DO NOT RETRACT BLADE GUARD (ITEM# 14) MANUALLY. GUARD RETRACTS AUTOMATICALLY.

### WHAT YOU SHOULD KNOW WHILE SAWING

1. Select the correct saw blade appropriate to the material being cut. (mild steel, stainless steel or aluminum)
2. The material surface should be clean and level, free from rust, dirt, scale, and other debris.
3. Material may become heat treated if flame cut. Always avoid cutting near these areas whenever possible.
3. Adjust the base plate to the desired bevel angle by loosening and then re-tightening the Bevel Lever Lock (item# 93) at front of saw and the Rear Bevel Lock at rear of saw.
4. When making long, straight cuts in sheet stock, insert the edge guide to the desired width and secure with thumb screws (item# 73), or use the electronic Laser Guide.
5. Adjust to the proper depth of cut by loosening and re-tightening the rear Lever Lock (item# 93) at rear of saw. In most cases, depth should be set at maximum unless there are obstructions below the work surface. Depth can be set by observing index marks printed on housing along depth bracket.
6. Connect machine to power source.
7. Firmly grasp guide handle and trigger handle switch (item# 82 and 83).
8. Position saw base plate on work surface near the cutting area.
9. While observing Cautions and Warnings above, turn on the Laser On/Off switch. If Laser does not turn on, check batteries. (Note: Laser is not required for saw operation.)
10. When ready, start saw motor by activating trigger switch (item# 83).
11. Slowly approach material edge and gently apply pressure until saw blade has established a cutting groove in the material.
12. Apply smooth, constant pressure without over-loading saw motor.

#### WARNING!

IF SAW MOTOR SHOULD STALL OR STOP BEFORE A COMPLETE CUT IS MADE ALWAYS REMOVE BLADE FROM MATERIAL BEFORE ATTEMPTING TO RESTART MOTOR. FAILURE TO DO SO COULD RESULT IN PERSONAL INJURY.

### AFTER COMPLETING THE CUT

1. After the cut, release trigger switch to the "OFF" position.
2. When saw motor completely stops, place saw on secure and level surface.
3. Turn Laser On/Off switch to Off position.

## OPERATION (continued)

**For best performance and to prevent overheating, empty the chip collector often.**

### EMPTYING THE CHIP COLLECTOR

#### **WARNING!**

ALWAYS DISCONNECT THE SAW FROM POWER SOURCE BEFORE CHANGING BLADES, CLEARING CHIPS OR MAKING ADJUSTMENTS.

1. Loosen the two Chip Collector Cover Retaining screws (item# 22).
2. Remove chip collector from the right side of saw. (item# 3)
3. Empty chip collector by tipping the cover sideways and letting the chips and debris fall out. Clean all debris from saw body.
4. Install chip collector on saw and fasten securely by tightening thumbscrews.

#### **WARNING!**

FAILURE TO SECURE THE CHIP COLLECTOR COVER MAY RESULT IN UNCONTROLLED DISCHARGE OF CHIPS AND OPERATOR INJURY.

ALWAYS VERIFY PROPER INSTALLATION OF COVER AND CHECK FREQUENTLY.

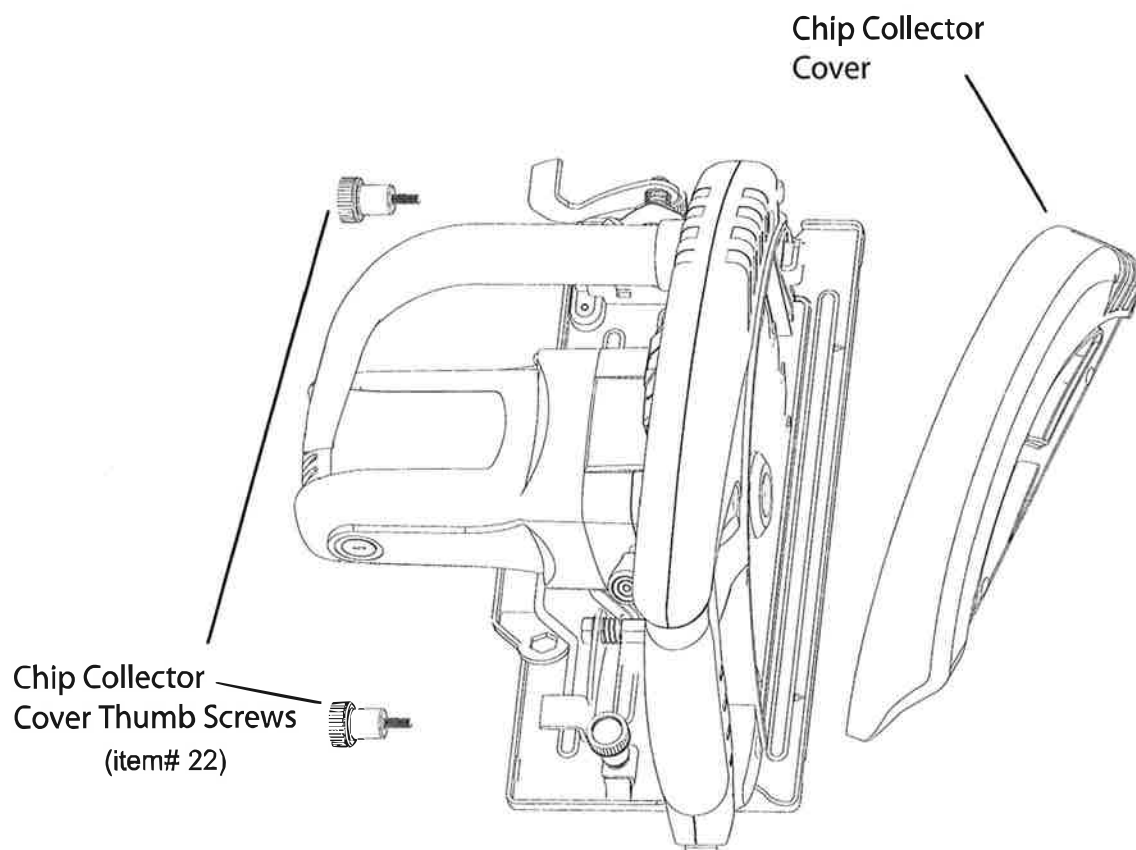



# TROUBLESHOOTING CHECKLIST

## EHC.230/3 (9") METAL CUTTER



ALWAYS DISCONNECT THE SAW FROM POWER SOURCE BEFORE TROUBLESHOOTING.

### 1. Machine will not turn on

- Inspect power cord for damage. Check continuity. Replace if needed. (PN SM-59)
- Inspect brushes for excessive wear. Replace if needed. (PN SM-46) (2)
- Do not exceed 30 minutes run time without cool down of saw.
- Check trigger switch for continuity. Replace if needed. (PN SM-63)

### 2. Losing Power

- Inspect brushes and replace if needed. (PN SM-46) (2)
- Extension cord too long. Limit cord length to 50' or less.
- Extension cord too thin. Use 12 AWG or larger.

### 3. Blade Guard Sticks

- Remove guard and remove any foreign material. Wipe any excess material from guard & face plate. Guard must move freely. Use light grease on mating contact surfaces to aid in movement.
- Check guard return spring for sufficient tension. Replace if spring is weak. (PN SM-16)
- Check guard for distortion. Replace if distorted or damaged. (PN SM-14)

### 4. Blade Spins on Spindle

- Check for proper tightness and installation. Inspect inner blade flange (PN SM-12) and outer blade flange (PN SM-10) for wear or damage. Replace if wear is excessive.
- Check flange mating surfaces for flatness. Replace if excessive distortion exists.
- Check to ensure flat washer is present between bolt head and outer blade drive flange.

### 5. Low Blade Life/Teeth Chipping

- Wrong blade for the type of material.  
230.0003 saw blade for use on steel/aluminium.
- Aggressive contact with blade into material. The blade must be allowed to do the work.
- Too much vibration due to insufficient clamping, worn or bent blade, or worn parts (see "Saw Vibrates" below).

### 6. Saw Vibrates

- Check blade for tightness.
- Inspect inner blade flange (PN SM-12) and outer blade drive flange (PN SM-10) for wear or damage. Replace if needed.
- Check to ensure work is properly clamped. Both primary and cut-off piece can cause vibration.
- Check bevel lock and depth lock for tightness. (PN SM-93)
- Check blade teeth for missing carbide, bends or cracks.

### 7. Laser Won't Track

- Adjust Laser alignment screw (PN SM-99) with laser turned on.

# PRODUCT REGISTRATION AND WARRANTY CARD

Thank you for purchasing a EUROBOOR® product!  
Please fill out this form and return promptly so that we may register your purchase.

Model# \_\_\_\_\_ Serial # \_\_\_\_\_ Date of Purchase \_\_\_\_\_

*Please detach and retain this top portion for your records.*

Mr.  Mrs.  Ms.  Miss

First Name \_\_\_\_\_ Last Name \_\_\_\_\_

Company Name \_\_\_\_\_

Street Address \_\_\_\_\_

City \_\_\_\_\_ State \_\_\_\_\_ Zip \_\_\_\_\_

Phone Number \_\_\_\_\_ Fax Number \_\_\_\_\_ E-mail Address \_\_\_\_\_

May we contact you by: Mail  Fax  E-mail Address

Model \_\_\_\_\_ Serial# \_\_\_\_\_ Date of Purchase \_\_\_\_\_

Where did you purchased your EUROBOOR product from \_\_\_\_\_

What are the top two reasons that influenced your purchase of this EUROBOOR brand product?

- |   |   |                                       |
|---|---|---------------------------------------|
| Reputation <input type="checkbox"/>       | Value for price <input type="checkbox"/>        | Web site <input type="checkbox"/>     |
| Safety features <input type="checkbox"/>  | Magazine ad <input type="checkbox"/>            | Availability <input type="checkbox"/> |
| Recommendation <input type="checkbox"/>   | Reputation of retailer <input type="checkbox"/> | Other <input type="checkbox"/>        |
| Style/Appearance <input type="checkbox"/> | Quality/Durability <input type="checkbox"/>     |                                       |

In your opinion, what is the BEST industry publication you regularly read? \_\_\_\_\_

Is this: A first time purchase?  An additional unit?  A replacement unit?  For which brand? \_\_\_\_\_

Additional comments: \_\_\_\_\_

Thank You! We value your answers and input.  
 Yes, put me on the EUROBOOR email list for special offers.

---

*Please tape here before mailing.*

---

---

---

**First Class  
Postage  
Required**

**ATTENTION: WARRANTY DEPARTMENT**

## SPECIFICATIONS

### Model EHC.230/3

#### DIMENSIONS AND SPECIFICATIONS

Height	340mm (13.4")
Width	340mm (13.4")
Length	466mm (18.4")
Weight	9.8kg (21lbs.)
Motor	230V - 1800W 50Hz / 2700 RPM
Blade Arbor	25.4mm (1.0")
Blade Diameter	230mm (9.0")
Depth of Cut/Pipe or Angle (maximum)	82.5mm (3.25")
Depth of Cut/Plate or Bar (maximum)	13mm Mild Steel (1/2") 13mm Aluminum (1/2") 8mm Stainless Steel (5/16")
Case Dimensions	394mm H (15.5") 381mm W (15") 546mm L (21.5")

## ACCESSORIES

#### Saw Blades

Application	Part #
For cutting mild steel / Aluminium	230.0003

YOUR EUROBOOR DISTRIBUTOR

## MAINTENANCE



**WARNING!**

ALWAYS DISCONNECT THE SAW FROM POWER SOURCE BEFORE CHANGING BLADES, CLEARING CHIPS OR MAKING ADJUSTMENTS.

### **CHANGING SAW BLADES**

Refer to the diagram below.

1. Place saw on a level, secure surface.
2. Remove chip collector cover (item #3) by loosening the chip cover retaining screws. (Item 22)
3. Engage spindle lock (item# 40).
6. Using supplied wrench, loosen and remove blade drive mounting bolt, washer and outer blade drive flange (item# 8, 9 and 10).
7. Remove saw blade. (item 11)
8. Thoroughly clean inner and outer blade drive flanges and blade mounting surface before installing new blade.
9. Reverse process to install new blade.

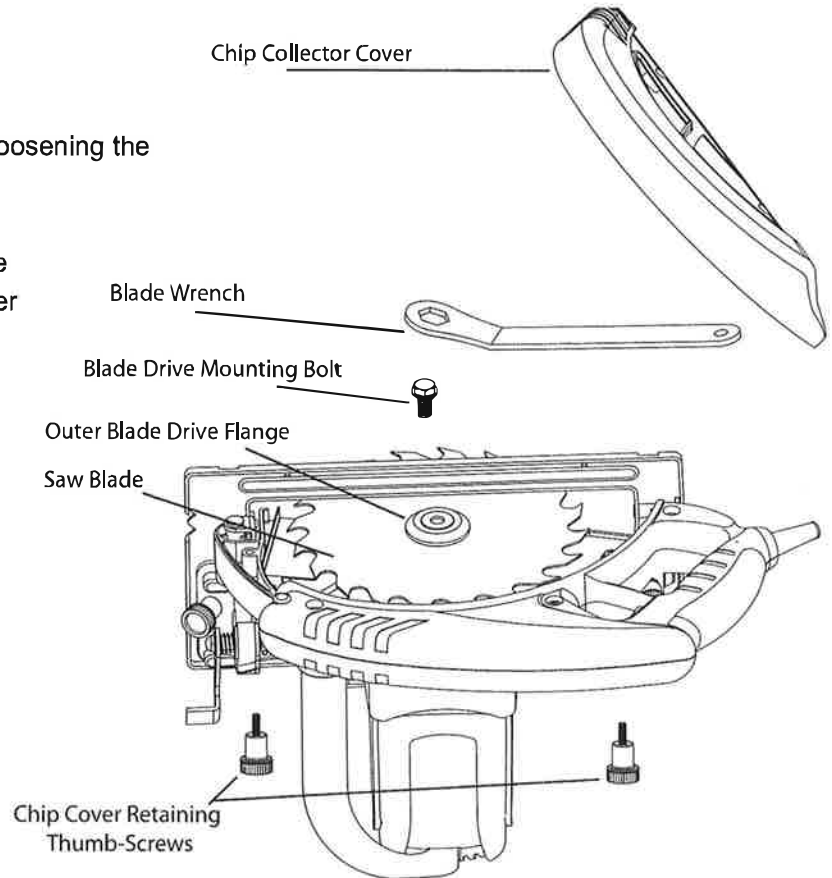

### **REPLACING MOTOR BRUSHES**

Refer to the diagram to the right.

1. Place saw on level, secure surface.
2. Remove two (2) motor brush retainer screws (item# 1) and slide the brushes out.
3. If the carbon rod is less than 6mm or if there are signs of burning or other wear, replace the brushes.
4. Reverse the process to re-assemble saw.

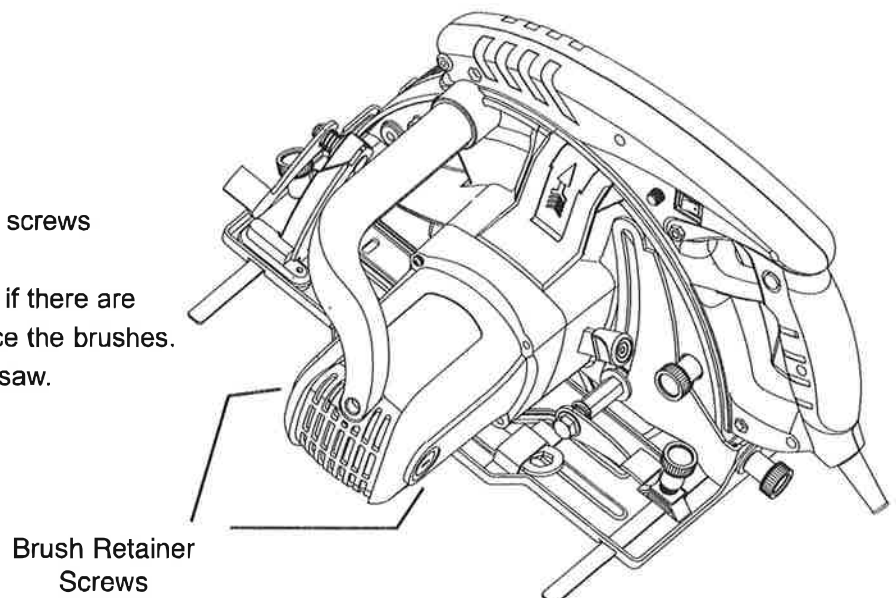

## OPERATION (continued)

### USING THE LASER ALIGNMENT GUIDE

#### **DANGER!**

**LASER RADIATION. AVOID DIRECT EYE EXPOSURE. DO NOT STARE INTO THE LASER LIGHT SOURCE.** Never aim light at another person or object other than the workpiece. Laser light can damage your eyes.



Avoid Exposure - Laser Radiation is emitted from this aperture.

#### **WARNING!**

**DO NOT USE TINTED GLASSES TO ENHANCE THE LASER LIGHT. Tinted glasses will reduce overall vision for the application and interfere with the normal operation of the tool.**

#### **WARNING!**

**NEVER AIM THE BEAM AT A WORKPIECE WITH A REFLECTIVE SURFACE.** Highly polished or similar reflective surfaces are not recommended for laser use where eye exposure is possible due to reflection. These surfaces could reflect the beam back toward the operator or bystanders.  
**ALWAYS CONSIDER THE PATH OF POSSIBLE BEAM DEFLECTION.**

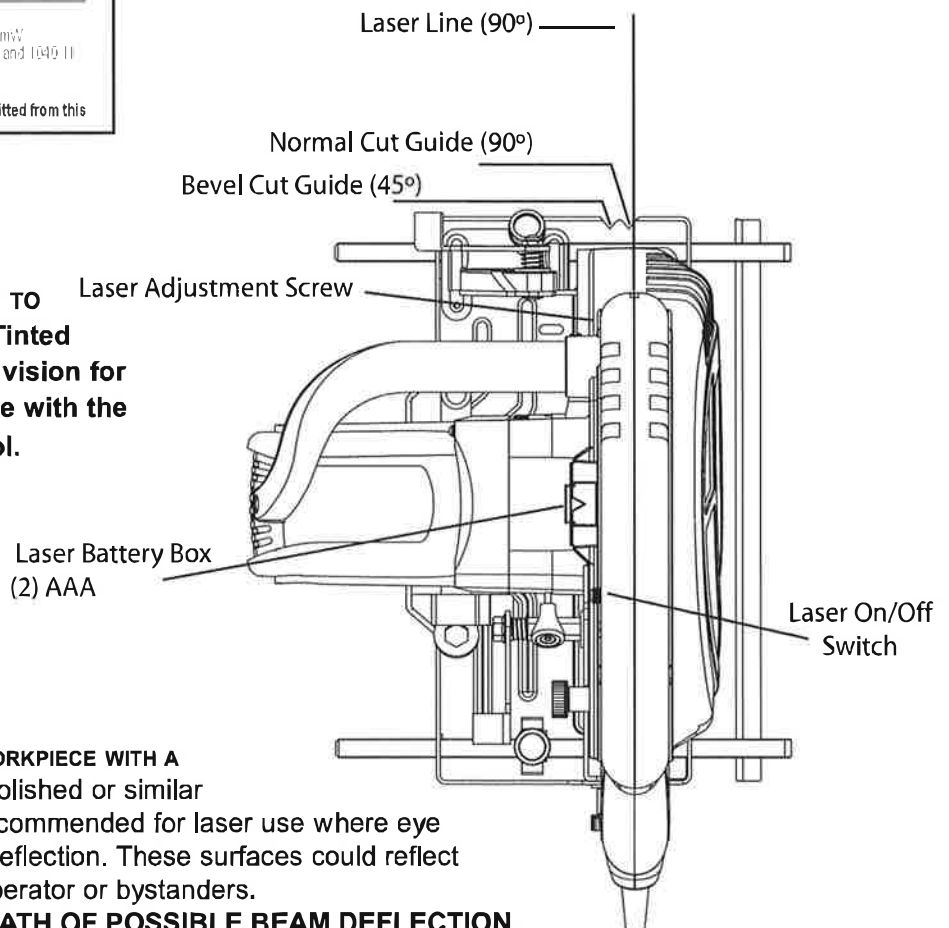

1. While observing Cautions and Warnings above, turn on the Laser On/Off switch. If Laser does not turn on, check batteries. (Note: Laser is not required for saw operation.)
2. Turn on saw with Trigger Switch and move saw into material while applying smooth, constant pressure during the cutting.
3. When cut is complete, release trigger switch to stop saw motor.
4. Turn Laser On/Off switch to Off position.

# ASSEMBLY

Your EUROBOOR® brand saw is shipped complete and protected inside a reusable carrying case. Remove all contents from the case and inspect to ensure no damage was incurred during shipping. Your EHC.230/3 Metal Cutter package should also include the following:

DESCRIPTION	PART #	QTY
OPERATOR'S MANUAL	LIT301RGM	1
EARPLUGS (2)	RGM80289	1
SAFETY GOGGLES	RGM80290	1
13MM WRENCH	SM-108	1
EDGE GUIDE	SM-109	1
9" STEEL BLADE (OPTIONAL)	RGMBL09	1
CARRYING CASE	SM-110	1

## GETTING STARTED



**CAUTION!**

ALWAYS DISCONNECT THE SAW FROM POWER SOURCE BEFORE MAKING ADJUSTMENTS.

Refer to the "Functional Description" on page 8 and "Exploded View" drawing on page 10. If required, assemble edge guide (item# 79) to base plate (item# 77), and adjust edge guide to desired position. Secure with thumb screw (item# 73). If a blade has not been installed, install an authorized saw blade as detailed in the "Changing Saw Blades" section (page 16).

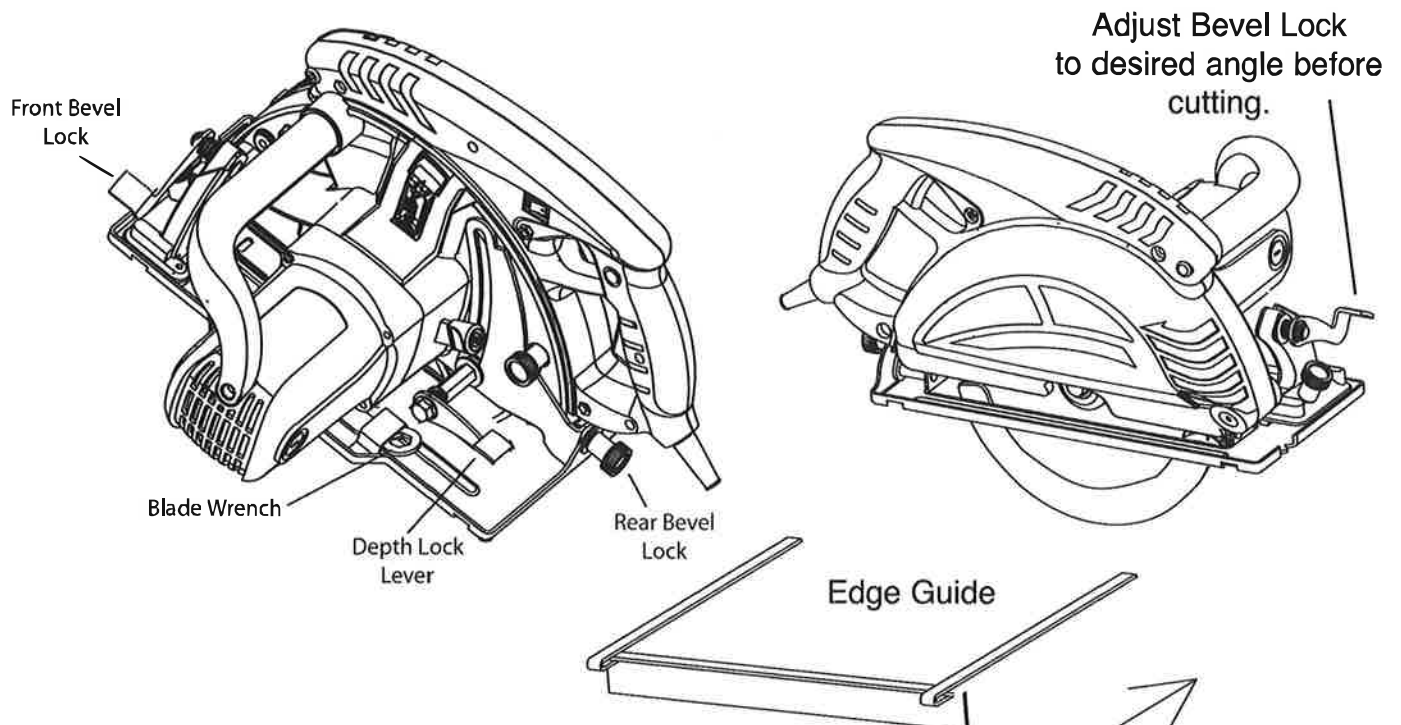

# EUROBOOR EHC.230/3 Exploded Drawing

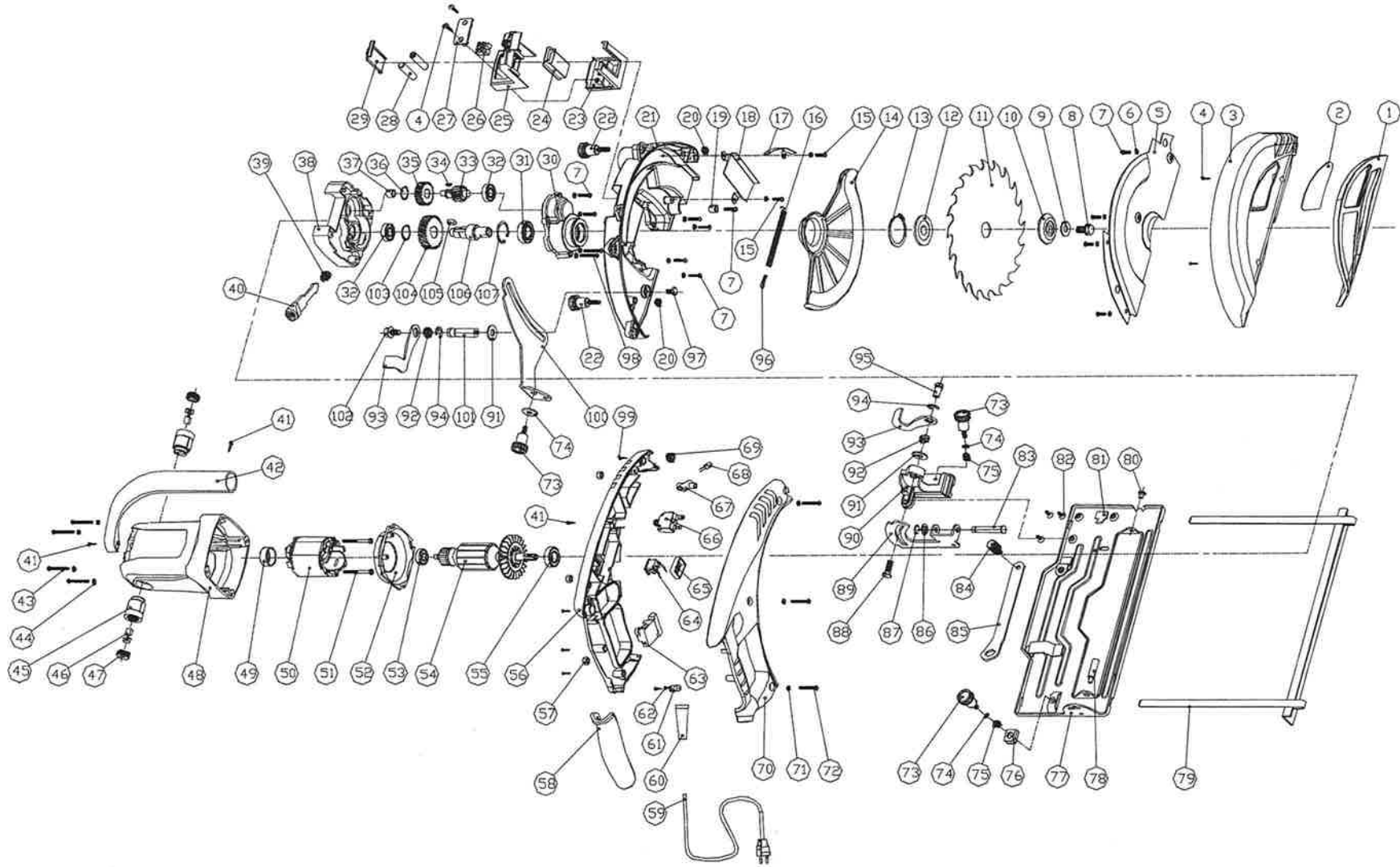

EXPLODED VIEW



## SPECIFIC SAFETY RULES (continued)

### **CAUSES AND OPERATOR PREVENTION OF KICKBACK**

Kickback is a sudden reaction to a pinched, bound or misaligned saw blade, causing an uncontrolled saw to lift up and out of the workpiece toward the operator. When the blade is pinched or bound tightly by the kerf (saw cut) closing down, the blade stalls and the motor reaction drives the unit rapidly back toward the operator. If the blade becomes twisted or misaligned in the cut, the teeth at the back edge of the blade can dig into the top surface of the material causing the blade to climb out of the kerf and jump back toward operator. Kickback is the result of tool misuse and/or incorrect operating procedures or conditions and can be avoided by taking proper precautions as given below:

Maintain a firm grip with both hands on the saw and position your body and arm to allow you to resist KICKBACK forces. KICKBACK forces can be controlled by the operator, if proper precautions are taken.

When blade is binding, or when interrupting a cut for any reason, release the trigger and hold the saw motionless in the material until the blade comes to a complete stop. Never attempt to remove the saw from the work or pull the saw backward while the blade is in motion or KICKBACK may occur. Investigate and take corrective actions to eliminate the cause of blade binding.

When restarting a saw in the workpiece, center the saw blade in the kerf and check that saw teeth are not engaged into the material. If saw blade is binding, it may walk up or KICKBACK from the workpiece as the saw is restarted.

Support large panels to minimize the risk of blade pinching and KICKBACK.

Large

panels tend to sag under their own weight. Supports must be placed under the panel on both sides, near the line of cut and near the edge of the panel.

Do not use dull or damaged blade. Dull or improperly set blades produce narrow kerf causing excessive friction, blade binding and KICKBACK.

Blade depth and bevel adjusting locking levers must be tight and secure before making a cut. If blade adjustment shifts while cutting, it may cause binding and KICKBACK.

## SPECIFIC SAFETY RULES (continued)

- DANGER! — Keep hands and body away from and to the side of the blade. Contact with blade will result in serious injury.
- WARNING! — To reduce the risk of injury, check lower guard. It must close instantly! Hold saw with both hands. Support and clamp work. Wear eye protection.

### **Additional Specific Safety Rules:**

DANGER! Keep hands away from cutting area and blade. Keep your second hand on auxiliary handle, or motor housing. If both hands are holding the saw, they cannot be cut by the blade.

- Keep your body positioned to either side of the saw blade, but not in line with the saw blade. KICKBACK could cause the saw to jump backwards. (See "Causes and Operator Prevention of Kickback.")
- Do not reach underneath the work. The guard can not protect you from the blade below the work.
- Check lower guard for proper closing before each use. Do not operate saw if lower guard does not move freely and close instantly. Never clamp or tie the lower guard into the open position. If saw is accidentally dropped, lower guard may be bent. Raise the lower guard and make sure it moves freely and does not touch the blade or any other part, in all angles and depths of cut.
- Check the operation and condition of the lower guard spring. If the guard and the spring are not operating properly, they must be serviced before use. Lower guard may operate sluggishly due to damaged parts, gummy deposits, or a buildup of debris.
- Always observe that the lower guard is covering the blade before placing saw down on bench or floor. An unprotected, coasting blade will cause the saw to walk backwards, cutting whatever is in its path. Be aware of the time it takes for the blade to stop after switch is released.
- NEVER hold piece being cut in your hands or across your leg. It is important to support the work properly to minimize body exposure, blade binding, or loss of control.
- Hold tool by insulated gripping surfaces when performing an operation where the cutting tool may contact hidden wiring or its own cord. Contact with a "live" wire will also make exposed metal parts of the tool "live" and shock the operator.
- When ripping always use a rip fence or straight edge guide. This improves the accuracy of cut and reduces the chance for blade binding.
- Always use blades with correct size and shape (diamond vs. round) arbor holes. Blades that do not match the mounting hardware of the saw will run eccentrically, causing loss of control.
- Never use damaged or incorrect blade washer or bolts. The blade washer and bolt were specially designed for your saw, for optimum performance and safety of operation.

## GENERAL SAFETY RULES (continued)

### **Personal Safety**

- *Stay alert, watch what you are doing and use common sense when operating a power tool. Do not use tool while tired or under the influence of drugs, alcohol, or medication. A moment of inattention while operating power tools may result in serious personal injury.*
- *Dress properly. Do not wear loose clothing or jewelry. Contain long hair. Keep your hair, clothing, and gloves away from moving parts. Loose clothes, jewelry, or long hair can be caught in moving parts.*
- *Avoid accidental starting. Be sure switch is off before plugging in. Carrying tools with your finger on the switch or plugging in tools that have the switch on invites accidents.*
- *Remove adjusting keys or switches before turning the tool on. A wrench or a key that is left attached to a rotating part of the tool may result in personal injury.*
- *Do not overreach. Keep proper footing and balance at all times. Proper footing and balance enables better control of the tool in unexpected situations.*
- *Use safety equipment. Always wear eye protection. Dust mask, non-skid safety shoes, hard hat, or hearing protection must be used for appropriate conditions.*

### **Tool Use and Care**

- *Use clamps or other practical way to secure and support the workpiece to a stable platform. Holding the work by hand or against your body is unstable and may lead to loss of control.*
- *Do not force tool. Use the correct tool for your application. The correct tool will do the job better and safer at the rate for which it is designed.*
- *Do not use tool if switch does not turn it on or off. Any tool that cannot be controlled with the switch is dangerous and must be repaired.*
- *Disconnect the plug from the power source before making any adjustments, changing accessories, or storing the tool. Such preventive safety measures reduce the risk of starting the tool accidentally.*
- *Store idle tools out of reach of children and other untrained persons. Tools are dangerous in the hands of untrained users.*
- *Maintain tools with care. Keep cutting tools sharp and clean. Properly maintained tools, with sharp cutting edges are less likely to bind and are easier to control.*
- *Check for misalignment or binding of moving parts, breakage of parts, and any other condition that may affect the tools operation. If damaged, have the tool serviced before using. Many accidents are caused by poorly maintained tools.*
- *Use only accessories that are recommended by the manufacturer for your model. Accessories that may be suitable for one tool, may become hazardous when used on another tool.*

### **SERVICE**

- *Tool service must be performed only by qualified repair personnel. Service or maintenance performed by unqualified personnel could result in a risk of injury.*
- *When servicing a tool, use only identical replacement parts. Follow instructions in the Maintenance section of this manual. Use of unauthorized parts or failure to follow Maintenance Instructions may create a risk of electric shock or injury.*

# Portable Metal Cutting Circular Saw

Congratulations on your purchase of a Euroboor Bladerunner Metal Cutter Saw. Please **complete** and mail your product registration card. Doing so will validate your machine's warranty period and **ensure** prompt service if needed. We Sincerely thank you for selecting a product from Euroboor BV.

## TABLE OF CONTENTS

Limited Warranty . . . . .	2
General Safety Rules and Specific Instructions . . . . .	3-4
Specific Safety Rules and Symbols . . . . .	5-8
Functional Drawings . . . . .	9
Exploded View . . . . .	10
Parts List . . . . .	11
Assembly View . . . . .	12
Operation . . . . .	13
Operation (Laser) . . . . .	14
Emptying the Chip Chamber . . . . .	15
Maintenance / Changing Saw Blades . . . . .	16
Troubleshooting Checklist . . . . .	17
Specifications . . . . .	18
Accessories . . . . .	18

## LIMITED WARRANTY

Euroboor BV will, within twelve (12) months from the original date of purchase, repair or replace **any** goods found to be defective in materials or workmanship, provided the product warranty registration card has been returned to Euroboor BV within thirty (30) days of purchase date (proof of purchase required). This warranty is void if tool is used on materials thicker than 13 mm (1/2") solid for aluminum, **13 mm** (1/2") for mild steel, or 8 mm (5/16") for solid stainless steel, has been damaged by accident, **neglect**, improper service, or other causes not arising out of defects in materials or workmanship. This **warranty** does not apply to machines and/or components which have been altered, changed, or modified **in any** way, or subjected to use beyond recommended capacities and specifications. Electrical components are subject to respective manufacturers' warranties. All goods returned defective shall be returned **prepaid** freight to Euroboor BV, which shall be the buyer's sole and exclusive remedy for defective goods. **In no** event shall Euroboor BV be liable for loss or damage resulting directly or indirectly from the **use** of merchandise or from any other cause. Euroboor BV is not liable for any costs incurred on such **goods** or consequential damages. No officer, employee or agent of Euroboor BV is authorized to make **oral** representations of fitness or to waive any of the foregoing terms of sale and none shall be **binding** on Euroboor BV.

Euroboor BV RESERVES THE RIGHT TO MAKE  
IMPROVEMENTS AND MODIFICATIONS TO DESIGN WITHOUT PRIOR NOTICE.

EUROBOOR BV  
Loodstraat 1-3  
2718 RV Zoetermeer  
The Netherlands