



## Parts List

### Hydraulic Cylinder

10301-10305

#### SINGLE-ACTING, SPRING RETURN HYDRAULIC CYLINDER

Max. Capacity: 11.2 Ton at 10,000 PSI

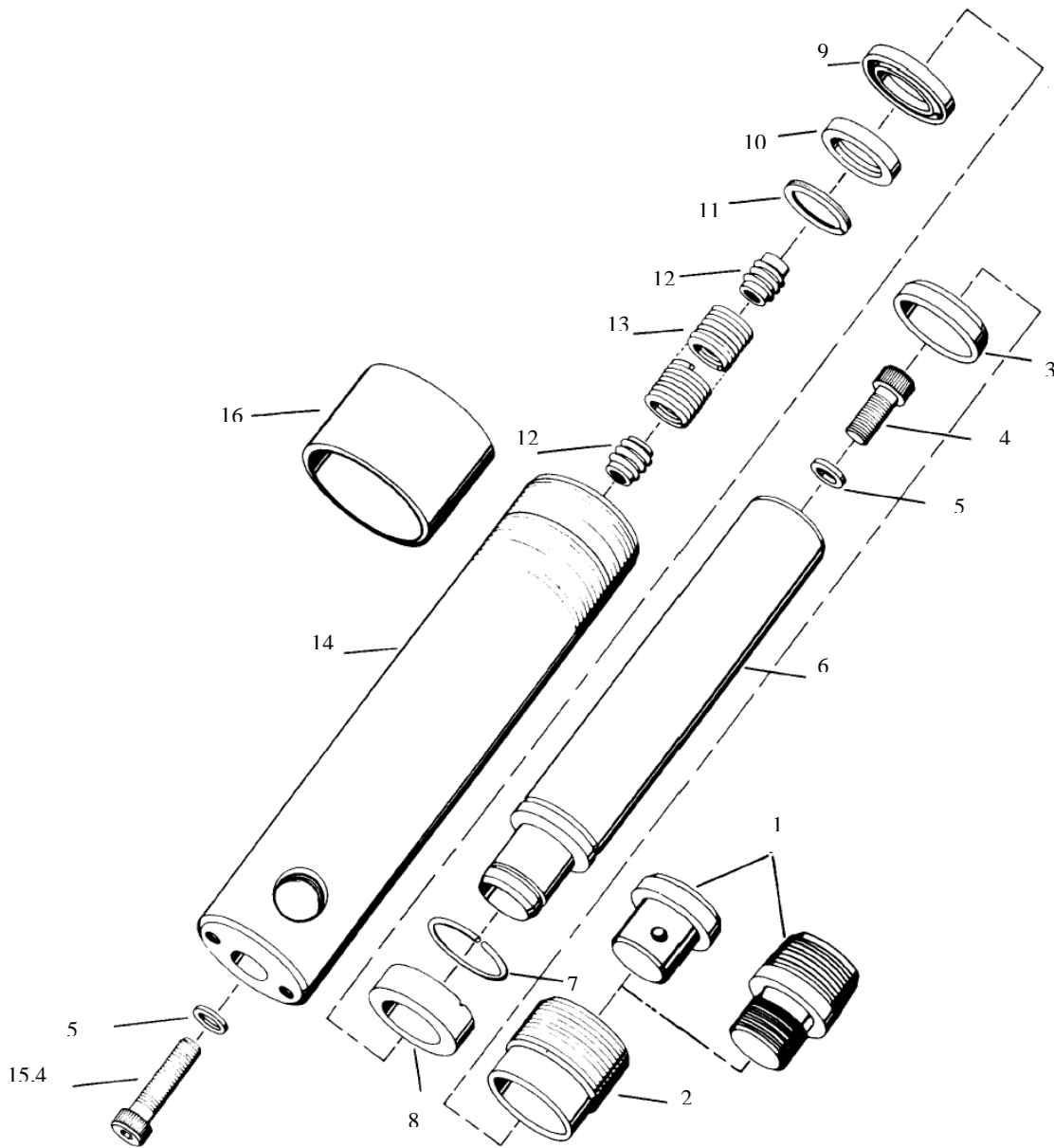

Item No.	Part No.	No. Req'd	Description
1	201362	1	Thread Adapter Assembly (not included with 89200-69, C108C-ADV, C104c-EMP & C1012C-ABC)
	202179	1	Thread Adapter (Torque to 100 ft. lbs.; For 43143 only)
	251513	1	Thread Adapter (for C106C-SAUER)
2	201365	1	Retainer Nut (Torque to 90/100 in. lbs.; For C101C, C101CN, C102C, C104C, 201581-C4, 420006, 2R101S, 2R102S, 2R104S, C102C-IMT, & C104-EMP)
	201366	1	Retainer Nut (Torque to 90/100 in. lbs.; For C-106C, C106CK, C108C, C108CK, C1010C, C1010C-CMI, C1012C, C104C, 43143, C108CM, 89200-69, 2R106S, 2R108S, C106C-SAUER, 2R101S, C1012C-ABC & C1010C-PTP)
3	†*201429	1	Rod Wiper
4	10006	1	Soc. Hd. Cap Screw (1/4-20 x 5/8 Lg.; Torque to 90/110 in. lbs.; For C104C, C106C, 106CK, C108C, C108CK, C108CM, C1010C, C1010C-CMI, C1012C, 43143, 89200-69, 201581-C4, 2R104S, 2R106S, 2R108S, C106C-SAUER, 2R1010S, C108C-ADV, C1010C-CHIEF, C106C-IMT, C1010C-IMT, C104-EMP, C1012C-ABC & C1010-PTP)
	10008	2	Soc. Hd. Cap Screw (1/4-20 x ¾ Lg.; Torque to 90/110 in. lbs.; For C102C, 420006, 2R102S, & 102C-IMT)
	17203	2	Soc. Hd. Cap Screw (1/4-20 X 7/8 Lg.; Torque to 50/70 in. lbs.; For C101C, C101CN, & 2R101S)
	16064	2	Soc. Hd. Cap Screw (1/4-20 x 3-1/2 Lg.; Torque 90/110 in. Lbs.; For C1014C)
5	†*10442	2	Copper Washer
6	38061	1	Piston Rod (For C101C, C101CN & 2R101S)
	36087	1	Piston Rod (For C102C, 2R102S & C102C-IMT)
	38070	1	Piston Rod (For C104C, 201581-C4, 2R104S & C104C-EMP)
	42162	1	Piston Rod (For C1010C, C1010C-CMI, C1010C-CHIEF, 2R1010S, C1010C-IMT & C1010C-PTP)
	44815	1	Piston Rod ( For C1014C)
	420007	1	Piston Rod (For 420006)
	420221	1	Piston Rod (For C1012C & C1012C-ABC)
7	---	1	Retaining Ring (Note: This part is assembled on the piston rod [Item #6].)
8	201363	1	Piston Head (For C101C, C101CN, C102C, C104C, 201581-C4, 420006, 2R101S, 2R102S, 2R104S, C102C-IMT, & C104C-EMP)
	201364	1	Piston Head ( Assemble with groove toward shoulder.; For C106C, C106CK, C108C, C108CK, C1010C, C1010C-CMI, C1012CC, C1014C, C108CM, 43143, 89200-69, 2R106S, 2R108S, C106C-SAUER, C108C-ADV, C1010C-CHIEF, 2R1010S, C-106C-IMT, C1010C-IMT, C1012C-ABC, & C1010C-PTP)
9	*16067	1	U-cup Piston Seal
	†205704	1	U-cup
10	201359	1	Slip Retainer
11	*16076	1	Retaining Ring
12	201360	2	Spring Retainer (For all except 2R101S, C101CN & C101C)
	204414	2	Spring Retainer (For C1k01C, C101CN, & 2R101S)



Item No.	Part NO.	No. Req'd	Description
13	204249	1	Extension Spring (For C101C, C101CN, & 2R101S)
	201430	1	Extension Spring (For C102C, 420006, 2R102S, & C102-IMT)
	204250	1	Extension Spring (For C104C, 201581-C4, 2R104S, & C104C-IMT)
	20131	1	Extension Spring (For C106C, C106CK, 43143, 89200-6, C106C-SAUER, 2R106S, & C106-EMP)
	207695	1	Extension Spring (For C108C, C108CK, C108CM, C108C-ADV, & 2R108S)
	201432	1	Extension Spring (For C1010C, C1010C-CMI, C1010C-CHIEF, 2R1010S, C101C-IMT & C1010C-PTP)
14	43112	1	Cylinder Body (For C101C & 2R101S)
	42158	1	Cylinder Body (For C102C, 2R102S, & C102C-IMT)
	43113	1	Cylinder Body (For C104C, 201581-C4, 2R104S, & C104C-EMP)
	42160	1	Cylinder Body (For C106C, C106CK, 43143, 89200-69, 2R106S, & C106C-IMT)
	44812	1	Cylinder Body (For C108C, C108CK, C108CK, C108-ADV, 2R108S, & C108C-IMT)
	42163	1	Cylinder Body (For C1010C, C1010C-CMI, C101C-CHIEF, 2R1010S, C1010C-IMT & C1010C-PTP)
	44816	1	Cylinder Body (For C1014C)
	420008	1	Cylinder Body (For 420006)
	420222	1	Cylinder Body (For C1012C & C1012C-ABC)
	420700	1	Cylinder Body (For C108CM)
15	10020	1	Soc. HD. Cap Screw (1/4-20 x 1-1/4 Lg.; Torque to 90/110 in. lbs.; For C104C, 201581-C4, 2R104S, & C104C-EMP)
	16064	1	Soc. Hd. Cap Screw (1/4-20 x 3-1/2 Lg., Torque to 90/110 in. lb.; For C106C, C106CK, C108C, C108CK, C1010C, C1010-CMI, C106C-SAUER, C1012C, 43143, C108CM, 89200-69, 2R106S, 2R108S, 2R1010S, C108C-ADV, C1010C-CHIEF, C106C-IMT, C1010C-IMT & C1012C-ABC)
	36146	1	Thread Protector (Plastic – Not included on 43143, 89200-69, C104C-EMP, 420006 & C1012C-ABC)

**PARTS INCLUDED BUT NOT SHOWN**

210470	1	Trade Name Decal (For 2R101S)
210471	1	Trade Name Decal (For 2R102S)
210472	1	Trade Name Decal (For 2R104S)
210473	1	Trade Name Decal (For 2R106S)
210474	1	Trade Name Decal (For 2R108S)
210847	1	Trade Name Decal (For 2R1010S)
420102	1	Full Coverage Decal (For C101C)
202173	1	Trade Name Decal (For C101CN)
420124	1	Full Coverage Decal (For C102C & C102C-IMT)
420106	1	Full Coverage Decal (For C104C)
420107	1	Full Coverage Decal (For C106C, C106CK, & C106C-IMT)
420109	1	Full Coverage Decal (For C1010C, C1010C-CMI, & C1010C-IMT)
420110	1	Full Coverage Decal (For C101C)
420220	1	Full Coverage Decal (For C101C)
420582	1	Full Coverage Decal (For C101C)
203908	1	Warning Decal (Shipped loose with C108C-ADV)
212064	1	Warning Decal (For C101CN)



Item No.	Part No.	No. Req'd	Description
	10606	1	Ram Half Coupler (For Power Team models except C1010C-CMI & 420006)
	210916	1	Ram Half Coupler (For 2R102S, 2R102S, 2R104S, 2R106S, 2R108S, 2R1010S)
	211061	1	Plug (For C108C-ADV & C104C-EMP)
	†19526	1	O-ring (1" x 3/3" x 1/8"; for coupler)
	†206554	1	U-cup Backup washer
	†205724	1	Decal (Viton)
	350547	1	Handle (For C106CK & C108CK)
	205884	1 ft.	Strapping (For C106CK & C10CK)
	250881	1	Tensioner Plate (For C106CK & C108CK)
	251035	1	Soc. Set Screw (For C106CK & C108CK)
	251451	1	Warning Decal (For C104C-EMP; Shipped loose)
	251616	1	Quick Coupler Plug (For C102C-IMT, C106C-IMT, & C1010C-IMT)
	9682	1	Straight Fitting (For C102C-IMT, C106C-IMY, & C1010C-IMT)
	11127	1	Plug (For C1012C-ABC)

Part numbers marked with an asterisk (\*) are contained in Standard Repair Kit No. 300116.

Part numbers marked with a dagger (†) are contained in Viton Seal Kit No. 300211.

## SPRING & RETAINER ASSEMBLY

The spring must not extend beyond the threads of the spring retainer on

Either end. Stretch, clean and lubricate the spring before assembly.

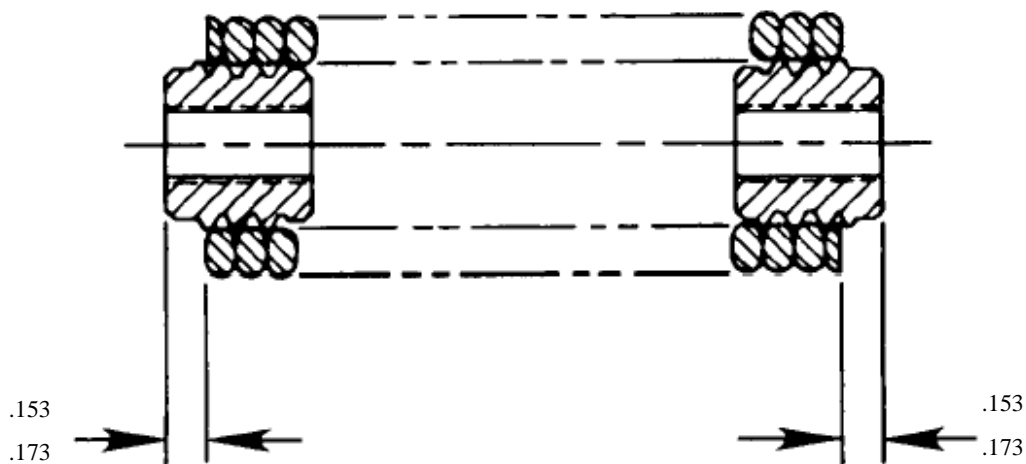

Refer to any operating instructions included with this product for detailed information about operation testing, disassembly, reassembly, and preventive maintenance.

Items found in this parts list have been carefully tested and selected. **Therefore: Use only genuine replacement parts!**



# Repair Parts Sheet

10301, 10302, 10303, 10305

**INSTALL ALL KIT COMPONENTS TO INSURE A COMPLETE AND PROPER REPAIR OF THE CYLINDER.**

## ▲ CAUTION

This product, and all tire tools, should be used only by persons properly trained according to OSHA regulation #29CFR1910.177, "Servicing Single-Piece & Multi-Piece

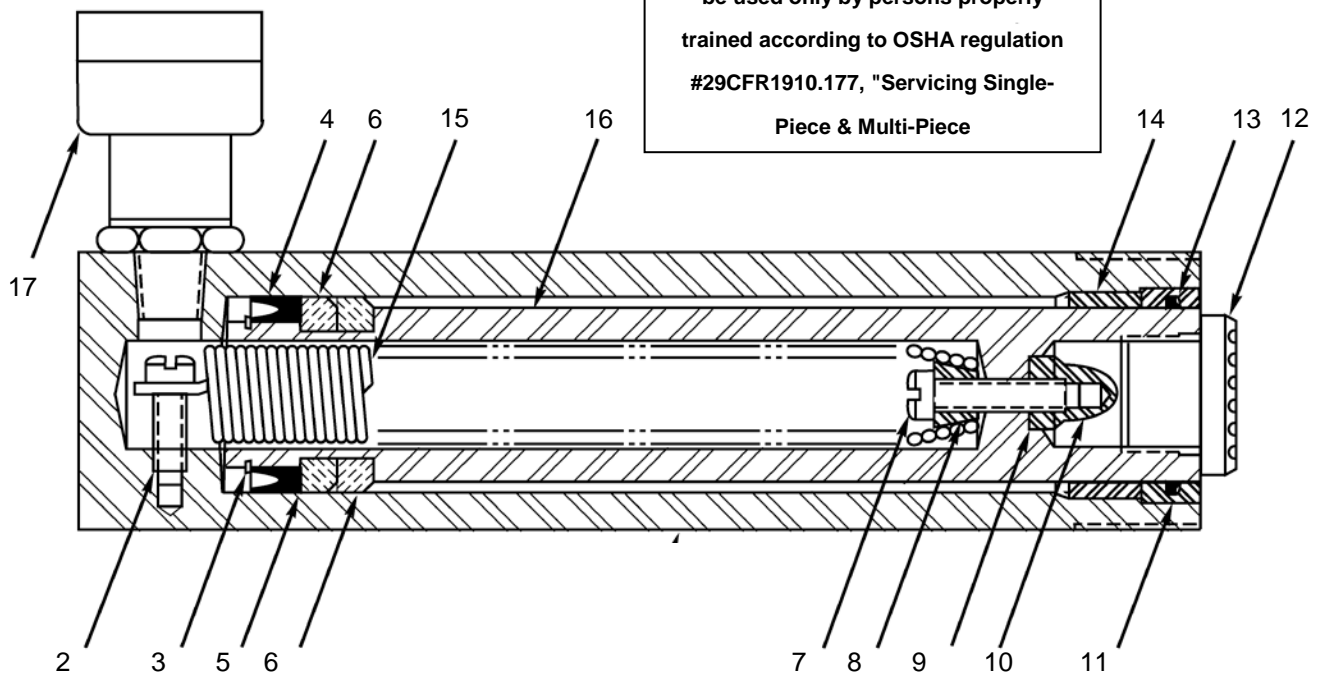

**Note:** Rod bearings (Item 6) to be assembled with splits staggered 90° apart.

**Note:** Models ESC-102 and ESC-104 do not have a Bushing, Gasket, Acorn Nut or Bearing Sleeve due to their lower stroke. These models have only one set of Rod Bearings.

**Note:** Cylinder Base, Item #1, is not available as a service item. Order complete cylinder.

## SPECIFICATIONS

Description	10301	10302	10303	10305
Rated Capacity	10 Ton	10 Ton	10 Ton	10 Ton
Plunger Stroke	21/8 Inch	41/8	61/8 Inch	101/4 Inch
Hydraulic Pressure	10,000 psi	10,000 psi	10,000 psi	10,000 psi





# Repair Parts Sheet

10301, 10302, 10303, 10305

## Repair Parts Sheet

Item No.	10301	10302	10303	10305	Qty.	Description
2	*	*	*	*	1	Screw 1/4-28 UNF X 1"
3	*	*	*	*	1	Retaining Ring
4	*	*	*	*	1	U-Cup
5	*	*	*	*	1	Washer
6	G382107 (1)	G382107 (1)	G382107	G382107	2	Rod Bearing
7	DA2286028	DA2286028	(See Note A)	(See Note A)	1	Screw
8	Not Required	.....	F948209	F948209	1	Bushing
9	.....	.....	*	*	1	Gasket
10	.....	.....	G833055	G833055	1	Acorn Nut
11	G385044		G385044	G385044	1	Bearing Stop Ring
12	A102G		A102G	A102G	1	Saddle Assembly
13	*	*	*	*	1	Wiper
14	.....	.....	G831446	G831446	1	Bearing Sleeve
15	L202110SR	CB425110SR	F937110SR	F938110SR	1	Spring (incl. item 7,8,9,10)
16	DA2283040	DA2284040	G838040	G830040	1	Plunger
17	10606	10606	10606	10606	1	Half Coupler
	CD-411	CD-411	CD-411	CD-411	1	Dust Cap (not shown)

**Note A:** ESC106 uses a 1/4-28 UNF X 1 1/4 long.

Indicates items included in, and available only as part of Repair Kit RC102K.





# Instruction Sheet

## Hydraulic Cylinders

### CONTENTS

English .....	2-6
Deutsch .....	7-11
Français .....	12 à 16
Español .....	17-21
Italiano .....	22-26
Nederlands .....	27-31

### IMPORTANT RECEIVING INSTRUCTIONS

Visually inspect all components for shipping damage. If any shipping damage is found, notify carrier at once. Shipping damage is NOT covered by warranty. The carrier is responsible for all repair or replacement cost resulting from damage in shipment.

### SAFETY INFORMATION



#### WARNING

**STAY CLEAR OF LOADS SUPPORTED BY HYDRAULICS.**  
A cylinder, when used as a load lifting device, should never be used as a load holding device. After the load has been raised, it should be blocked.



#### WARNING

**DO NOT EXCEED EQUIPMENT RATINGS.**

- Never attempt to lift a load weighing more than the capacity of the cylinder. Overloading causes equipment failure and possible personal injury.
- These cylinders are designed for a maximum pressure of 10,000 psi (700 bar). Do not connect these cylinders to a pump with a higher pressure rating.

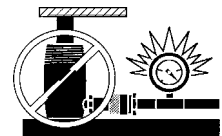

 **WARNING**

**BE SURE SETUP IS STABLE BEFORE LIFTING LOAD.**

- The cylinder should be placed on a flat surface that can support the load. Where applicable, use a cylinder base for added stability. Do not weld or otherwise modify the cylinder to attach a base or other support.
- Avoid situations where loads are not directly centered on the cylinder plunger. Off-center loads produce considerable strain on cylinders and plungers. In addition, the load may slip or fall, causing potentially dangerous results.
- Distribute the load evenly across the entire saddle surface. Tilt saddles are available to reduce offset loading (except 100 ton models). Always use a saddle to protect the plunger when threaded attachments are not used.

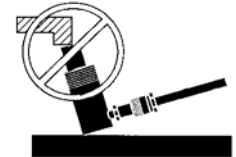

 **WARNING**

**USE ONLY RIGID PIECES TO HOLD LOADS.** Carefully select steel or wood blocks that are capable of supporting the load. Never use a hydraulic cylinder as a shim or spacer in any lifting or pressing application.

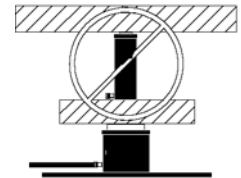

 **WARNING**

**ONLY USE HYDRAULIC CYLINDER IN A COUPLED SYSTEM.**

Never use a cylinder with unconnected couplers. If the cylinder becomes extremely overloaded, the coupler check ball and/or hydraulic oil may shoot out of the cylinder causing severe personal injury.





 **CAUTION**

**AVOID DAMAGING HYDRAULIC HOSE.**

- Avoid sharp bends and kinks when routing hydraulic hoses. Using a bent or kinked hose will cause severe back-pressure. Also, sharp bends and kinks will internally damage the hose leading to premature failure.

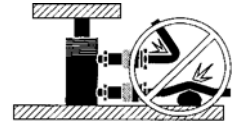

- Do not drop heavy objects on hose. A sharp impact may cause internal damage to hose wire strands. Applying pressure to a damaged hose may cause it to rupture.

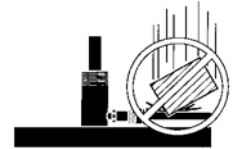

- Do not use the hydraulic hose to carry a hydraulic component (i.e. pumps, cylinders and valves).



 **CAUTION**

**KEEP HYDRAULIC EQUIPMENT AWAY FROM FLAMES AND HEAT.**

Excessive heat will soften packings and seals, resulting in fluid leaks. Heat also weakens hose materials and packings. For optimum performance **DO NOT** expose equipment to temperatures of 150°F (65°C) or higher. Protect hoses and cylinders from weld spatter.

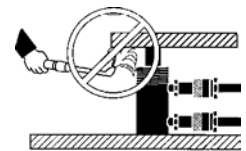

# INSTALLATION

1. Make hydraulic connections. Use a pump with a release valve or a 3-way valve and one hose for single-acting cylinders (1). Use a pump with a 4-way valve and two hoses for double-acting cylinders (2).

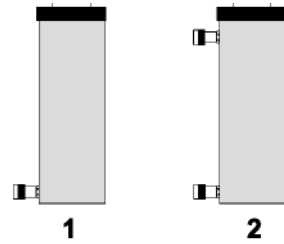

**IMPORTANT:** Double-acting cylinders must have both couplers connected.

Fully hand-tighten all couplers. Loose coupler connections will block the flow of oil between the pump and the cylinder.

2. Remove air from the cylinder as shown below.

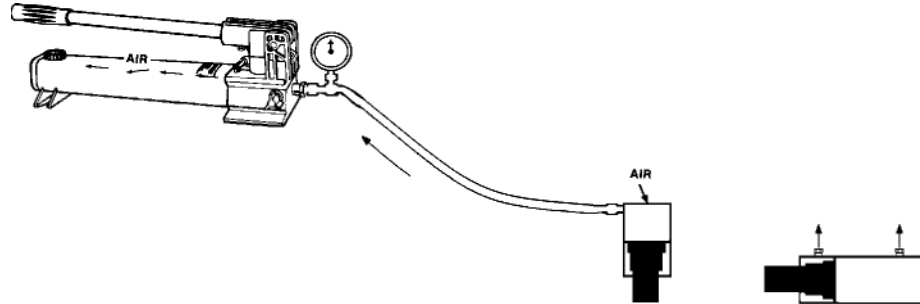

Single-acting cylinders: Position the cylinder so that the plunger is pointed down and the cylinder lower than the pump. Fully extend and retract the cylinder 2 or 3 times.

Double-acting cylinders: Lay the cylinder on its side and have the couplers facing up. Fully extend and retract the cylinder 2 or 3 times.

**NOTE:** Collar threads are rated for the full capacity of the cylinder when fully engaged in attachments.

**NOTE:** The use of cylinder attachments or extensions reduces the cylinder capacity by at least 50%.

## OPERATION



**DO NOT HANDLE PRESSURIZED HOSES.** Escaping oil under pressure can penetrate the skin, causing serious injury. If oil is injected under the skin, see a doctor immediately.



Operate the hydraulic pump to advance and retract the cylinder. Some single-acting cylinders are spring-return, others are load return. The speed of retraction is affected by the length of the hose and other restrictions in the line. Double-acting cylinders are powered in both directions by the pump. The cylinder stop ring is designed to take the full load. However, to reduce cylinder wear, use less than full stroke when possible.

## MAINTENANCE

1. Use dust caps when cylinders are disconnected from the hose. Keep entire cylinder clean to prolong cylinder life.
2. Store cylinders up-right to prevent seal distortion.

## TROUBLE SHOOTING

These cylinders should be repaired only by Authorized ESCO Technical Service Centers. Single-acting cylinders are spring loaded and require special disassembly techniques to prevent personal injury.

PROBLEM	POSSIBLE CAUSES
Cylinder will not advance.	Pump release valve open.
	Coupler not fully tightened.
	Oil level in pump is low.
	Pump malfunctioning.
	Load is too heavy for cylinder.
Cylinder advances part way.	Oil level in pump is low.
	Coupler not fully tightened.
	Cylinder plunger binding.
Cylinder advances in spurts.	Air in hydraulic system.
	Cylinder plunger binding.
Cylinder advances slower than normal.	Leaking connection.
	Coupler not fully tightened.
	Pump malfunctioning.
Cylinder advances but will not hold.	Cylinder seals leaking.
	Pump malfunctioning.
	Leaking connection.
	Incorrect system set-up.
Cylinder leaks oil.	Worn or damaged seals.
	Internal cylinder damage.
	Loose connection.
Cylinder will not retract or retracts slower than normal.	Pump release valve is closed.
	Coupler not fully tightened.
	Pump reservoir over-filled.
	Narrow hose restricting flow.
	Broken or weak retraction spring.
	Cylinder damaged internally.
Oil leaking from external relief valve.	Coupler not fully tightened.
	Restriction in return line.