

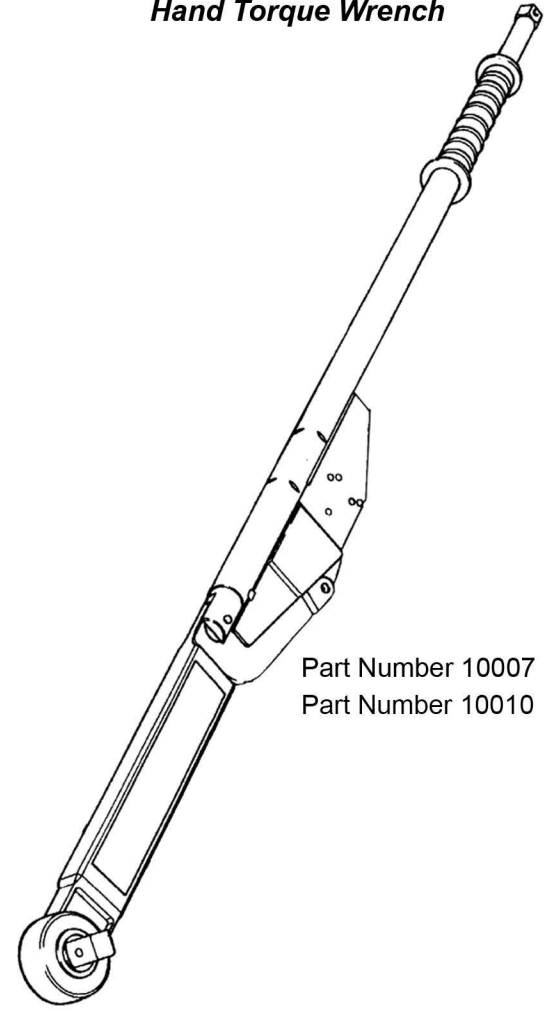

# Break-Back Style

Hand Torque Wrench

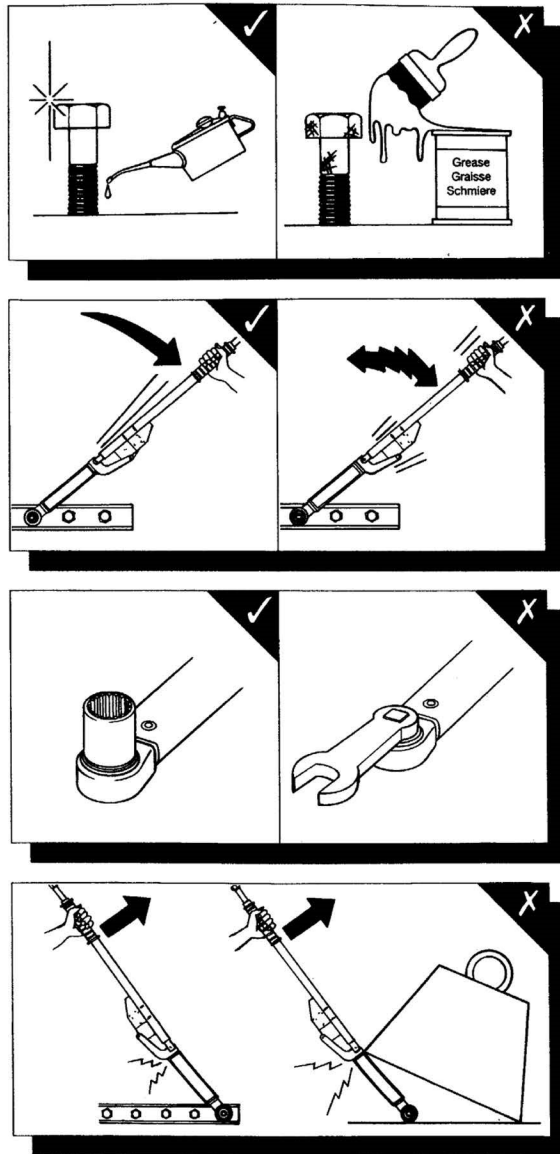
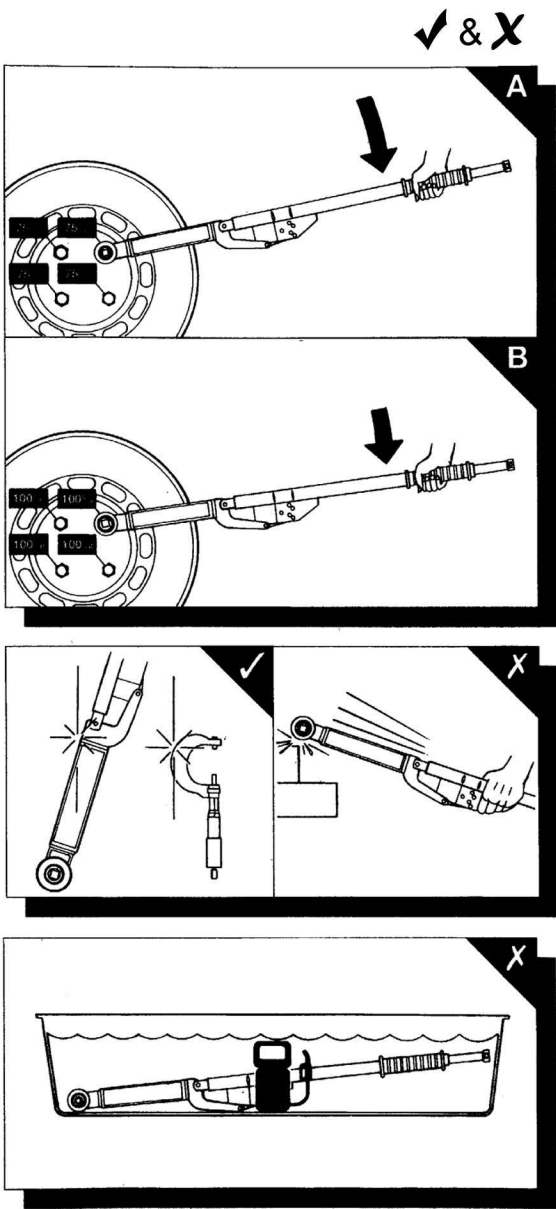

Part Number 10007  
Part Number 10010

✓ = Yes    X = No

✓ = Yes    X = No

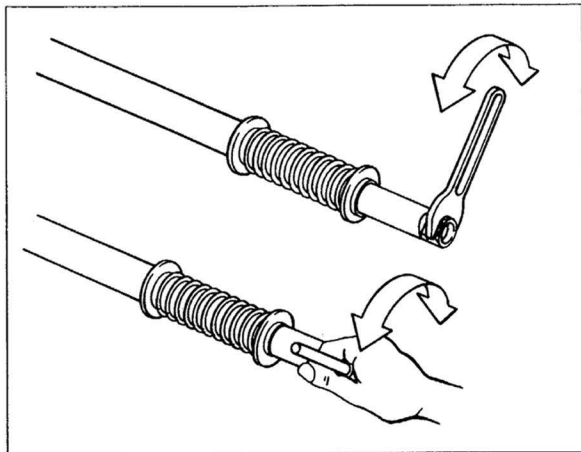

- Turn nut to adjust

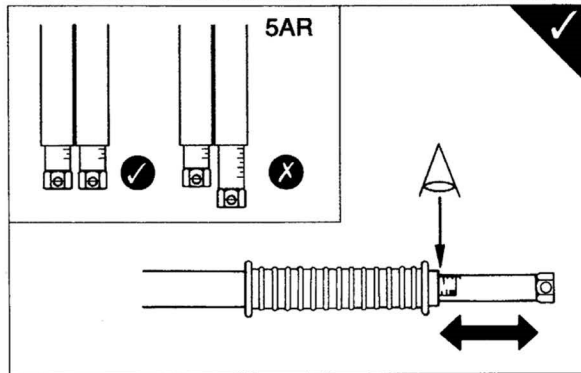

- Align required torque with the end of the body tube

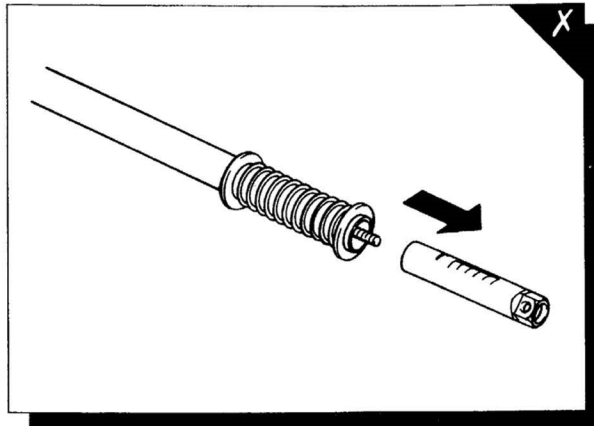

- Do not remove adjusting nut, calibration will be lost

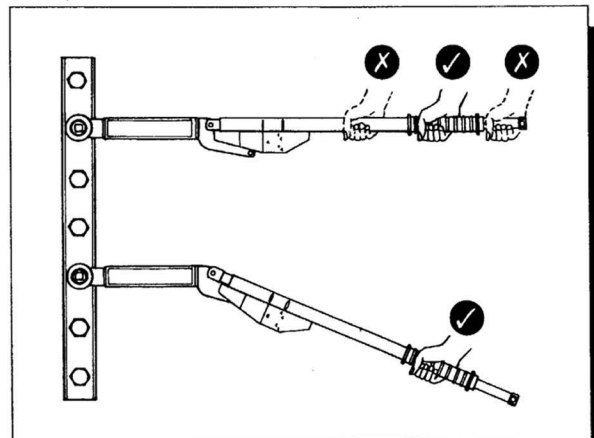

- Push from the centre of handle

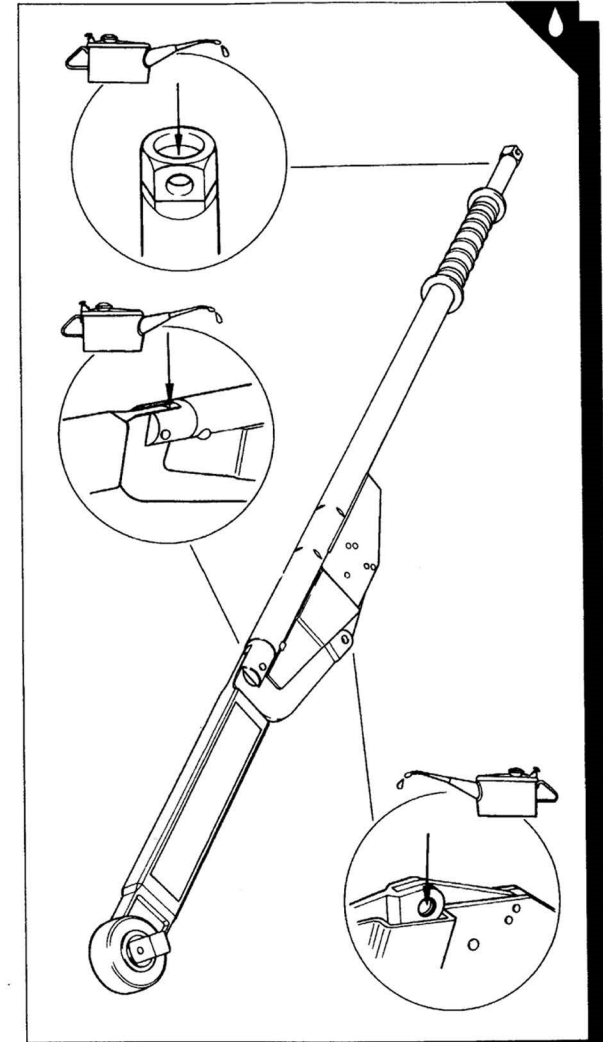

- Lubrication points

✓ = Yes    X = No

✓ = Yes    X = No