



### Disassembly Instructions – Dynorbital Silver Supreme

#### Motor Disassembly:

1. Invert the sander and position the **57092** Repair Collar around the housing. Secure the sander in a vise with the pad facing up. Important: Do not over tighten the sander in the vise or it will be difficult to remove the **59058** Lock Ring.
2. Use the **50679**, 26 mm Wrench to hold the balancer shaft stationary and remove the back-up pad. Turn pad counterclockwise. Remove the shroud.
3. Use the **56058** Lock Ring Wrench to remove the **59058** Lock Ring. Turn counterclockwise.
4. Remove the air motor from the housing and remove the **69352** Seal from the air motor.
5. Fasten the **96346** Bearing Separator (2") around the portion of the **69350** Cylinder that is closest to the **57891** Rear Bearing Plate. Place the bearing separator and the motor in the **96232** Arbor Press (#2) with the counterweight pointing down.
6. Use a 5/16" diameter flat-end drive punch as a press tool to push the shaft out of the **58368** Bearing.
7. Remove the rotor, vanes, key, front bearing plat and seal.
8. Fasten the **96346** Bearing Separator (2") between the **58368** Bearing and the top of the counterweight. Place the bearing separator and the motor shaft balancer in the **96232** Arbor Press (#2) with the counterweight pointing down. Push the shaft out of the **58368** Bearing.
9. Balancer Bearing and Shaft Disassembly:
  - a) Secure the counterweight in a vise with aluminum or bronze jaws with the hex of the **57069** Balancer Shaft pointing up. Use a thin flat-blade screwdriver to pick out the end of the **95630** Snap Ring and remove the snap ring from the motor shaft balancer.
  - b) Apply heat to the counterweight, and use the **56056** Bearing Puller to remove the balancer shaft and **56052** Bearing.
  - c) Fasten the **96346** Bearing Separator (2") between the **56052** Bearing and the hex end of the **57069** Balancer Shaft. Place the bearing separator and the balancer shaft in the **96232** Arbor Press (#2) with the hex end pointing down. Use a 5/16" diameter flat-end drive punch as a press tool to push the balancer shaft out of the **56052** Bearing. Remove the **59084** V-Seal.

Motor Disassembly Complete.

**Clean and inspect all parts before assembling.**

### Assembly Instructions – Dynorbital Silver Supreme

#### Motor Assembly:

1. Balancer Bearing and Shaft Assembly:
  - a) Install the **95630** Snap Ring around the **59084** V-Seal. Because of the loose fit, it will be necessary to hold it in position.
  - b) Install the **59084** V-Seal along with the **95630** Snap Ring onto the **57069** Balancer Shaft. Place the flexible lip of the seal toward the hex end of the balancer shaft so that the flat side will face the **56052** Bearing. **See Drawing 1**
  - c) Apply a small amount of Loctite #567 (or equivalent) to the outside diameter of the **57069** Balancer Shaft.
  - d) Use the **57091** Bearing Press Tool and the **96232** Arbor Press (#2) to install the **56052** Bearing (seal side toward hex) all the way onto the balancer shaft until the bearing is tight against the step on the shaft. **See Drawing 1**
2. Secure the motor shaft balancer in a vise with aluminum or bronze jaws so that the counterweight is pointing up.



## ***Disassembly/Assembly Instructions***

3. Apply a small amount of Loctite #271 (or equivalent) to the outside diameter of the **56052** Bearing. Install the balancer shaft with bearing into the bore of the motor shaft balancer. Compress and install the **95630** Snap Ring into the groove in the motor shaft balancer. - Remove assembly from the vise.
4. Install the **59083** Felt Seal into the **59057** Front Bearing Seal and install both onto the motor shaft balancer. **See Drawing 2**
5. Use the smaller diameter end of the **57091** Bearing Press Tool and the **96232** Arbor Press (#2) to install the **58368** Bearing onto the motor shaft balancer. **See Drawing 3**
6. Use the larger diameter end of the **57091** Bearing Press Tool and the **96232** Arbor Press (#2) to install the **69361** Front Bearing Plate carefully, fitting it to the bearing, felt and front bearing seal. **See Drawing 4**
7. Install the **56047** Key and rotor onto the motor shaft balancer.
8. Apply the **95842** Dynabrade Air Lube 10W/NR (or equivalent) to vanes and install them into the rotor.
9. Install the **69350** Cylinder so that the short line-up pin fits into the front bearing plate.
10. Use the RAISED OUTSIDE DIAMETER of the **96239** Bearing Press Tool and the arbor press to install the **58368** Bearing into the **57891** Rear Bearing Plate.
11. Use the small diameter end of the **57091** Bearing Press Tool and the arbor press to install the bearing/plate onto the motor shaft balancer. Important: Carefully press the bearing/plate down until it just touches the cylinder. This will establish a snug fit between the bearing plates and the cylinder.
12. Install the **59058** Lock Ring over the counterweight.
13. Carefully line-up the cylinder pin with the notch on the inside of the housing. Install the motor into the housing.
14. Invert the sander and position the **57092** Repair Collar around the housing. Secure the sander in a vise with the counterweight pointing up. Important: Do not over tighten the sander in the vise, or it will be difficult to install the **59058** Lock Ring. Use the **56058** Lock Ring Wrench to tighten the lock ring. Turn clockwise. (Torque to 28 N·m/250 in. lbs.)
15. Install the shroud. Use the **50679**, 26 mm Wrench to hold the balancer shaft stationary. Install the back-up pad. Turn pad clockwise.

Motor Assembly Complete.

### **Vacuum & Exhaust Assemblies:**

Reference the vacuum and exhaust exploded view and parts list for their correct order of assembly.

Tool Assembly Complete.

## Diagrams

**Drawing 1**

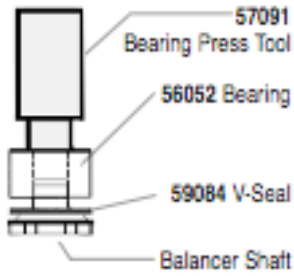

**Drawing 2**

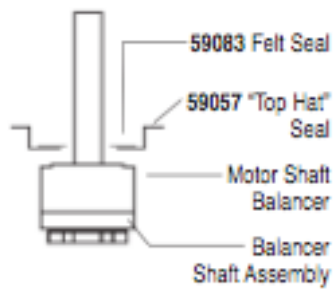

**Drawing 3**

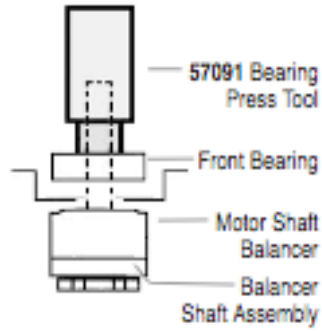

**Drawing 4**

