

# HiVac Dynorbital-Spirit®



12,000 RPM Air Powered Random Orbital Sander

## Air Tool Manual – Safety, Operation and Maintenance

SAVE THIS DOCUMENT, EDUCATE ALL PERSONNEL

### Models:

#### 3/16" Orbit

59115 - Self-Generated Vacuum

59117 - Central Vacuum

#### 3/32" Orbit

59116 - Self-Generated Vacuum

59118 - Central Vacuum



## ⚠ WARNING

Read and understand this tool manual before operating your air tool. Follow all safety rules for the protection of operating personnel as well as adjacent areas. Always operate, inspect and maintain this tool in accordance with the American National Safety Institute (ANSI) Safety Code for Portable Air Tools – B186.1. For additional safety information, refer to Safety Requirements for the Use, Care and Protection of Abrasive Wheels – ANSI B7.1, Code of Federal Regulation – CFR 29 Part 1910, European Committee for Standards (EN) Hand Held Non-Electric Power Tools – Safety Requirements and applicable State and Local Regulations.

## SAFETY LEGEND

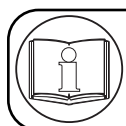

### ⚠ WARNING

Read and understand tool manual before work starts to reduce risk of injury to operator, visitors, and tool.

### ⚠ WARNING

Practice safety requirements. Work alert, have proper attire, and do not operate tools under the influence of alcohol or drugs.



### ⚠ WARNING

Eye protection must be worn at all times, eye protection to conform to ANSI Z87.1.

### ⚠ WARNING

Ear protection to be worn when exposure to sound, exceeds the limits of applicable Federal, State or local statutes, ordinances and/or regulations.



### ⚠ WARNING

Respiratory protection to be used when exposed to contaminants that exceed the applicable threshold limit values required by law.

### ⚠ WARNING

Air line hazard, pressurized supply lines and flexible hoses can cause serious injury. Do not use damaged, frayed or deteriorated air hoses and fittings.



### ⚠ WARNING

Some dust created by sanding, grinding, drilling, and other construction activities contain chemicals known to cause cancer, birth defects or other reproductive harm. Some examples of these chemicals are:

- Lead from lead-based paints
- Crystalline silica from bricks and cement and other masonry products
- Arsenic and chromium from chemically treated lumber

Your risk from these exposures varies, depending on how often you do this type of work. To reduce your exposure to these chemicals: work in a well ventilated area, and work with approved safety equipment, such as those dust masks that are specially designed to filter out microscopic particles.

### SAFETY INSTRUCTIONS

Carefully Read all instructions before operating or servicing any Dynabrade® Abrasive Power Tool.

Products offered by Dynabrade are not to be modified, converted or otherwise altered from the original design without expressed written consent from Dynabrade, Inc.

**Tool Intent:** HiVac Dynorbital-Spirit® Random Orbital Sander is used for sanding and finishing a variety of materials including wood, metal, plastic, fiberglass, solid surfaces, composites, rubber, glass and stone.

Do not use tool for anything other than its intended applications.

This power tool is not intended for use in potentially explosive atmospheres and is not insulated against contact with electrical power.

**Training:** Proper care, maintenance, and storage of your tool will maximize its performance.

- Employer's Responsibility – Provide HiVac Dynorbital-Spirit® operators with safety instructions and training for safe use of tools and accessories.

**Accessory Selection:**

- Abrasive/accessory RPM (speed) rating MUST be approved for AT LEAST the tool RPM rating.
- Before mounting an accessory, visually inspect for defects. Do not use defective accessories.

(continued on next page)

**SAFETY INSTRUCTIONS (continued)**

- Do not use grinding wheels or cut-off wheels.
- Use only recommended accessories.
- Follow tool specifications before choosing size and type of accessory.
- Only use recommended fittings and air line sizes. Air supply hoses and air hose assemblies must have a minimum working pressure rating of 150 PSIG (10 bars, g) or 150 percent of the maximum pressure produced in the system, whichever is higher. (See Tool Machine Specifications Table.)
- This tool is rear exhaust. Exhaust may contain lubricants, vane material, bearing grease, and other materials flushed through the tool.

**OPERATING INSTRUCTIONS**

**Warning:** Always wear eye protection. Operator of tool is responsible for following: accepted eye, face, respiratory, hearing and body protection.

**Caution:** Hand, wrist and arm injury may result from repetitive work, motion and overexposure to vibration.

- Keep hand and clothing away from working end of the air tool.
- Working end of the air tool has potential hazard of cutting.

**Operation:** Be sure that any loose clothing, hair and all jewelry is properly restrained.

- Secure inlet bushing on air tool with a wrench before attempting to install the air fitting to avoid damaging housing assembly.
- Check tool RPM (speed) with tachometer with air pressure set at 90 PSIG while the tool is running. If tool is operating at a higher speed than the RPM marked on the tool housing, or operating improperly, the tool must be serviced and corrected before use.
- With power source connected at the air tool relieve hose of air pressure and disconnect tool from air supply when changing recommended accessories.

**Caution:** Tool RPM must never exceed abrasive/accessory RPM rating.

- Connect air tool to power source. Be careful NOT to depress throttle lever in the process. **Do not expose air tool to inlet pressure above 90 PSIG or (6.2 Bars).**

**Caution:** After installing the accessory, before testing or use and/or after assembling tool, the HiVac Dynorbital-Spirit® must be started at a reduced speed to check for good balance. Gradually increase tool speed. DO NOT USE if tool vibration is excessive. Correct cause, and retest to insure safe operation.

- Release the throttle lever in case of an interruption of the energy supply.
- Ensure that self-fixing accessories are mounted concentrically.
- Make sure that work area is uncluttered, and visitors are at a safe range from the tools and debris.
- Potentially explosive atmospheres can be caused by dust and fumes resulting from sanding or grinding.
- Always use dust extraction or suppression systems which are suitable for the material being processed.
- Use a vise or clamping device to hold work piece firmly in place.
- Do not apply excessive force on tool or apply "rough" treatment to it.
- Always work with a firm footing, posture and proper lighting.

**Speed Regulator Flow Control**

Maximum Flow: Turn Clockwise.

Minimum Flow: Turn Counter-clockwise.

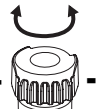

Report to your supervisor any condition of the tool, accessories, or operation you consider unsafe.

**Air System**

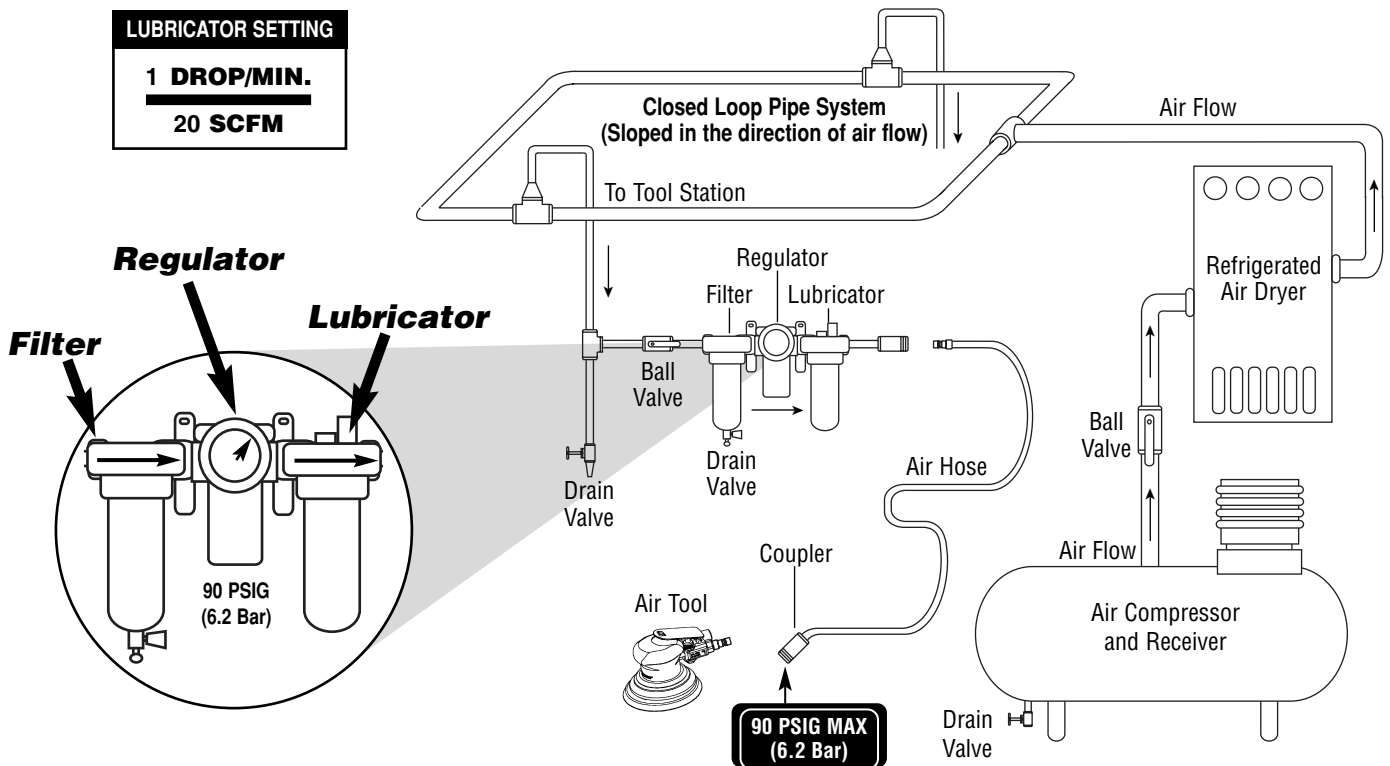

- Dynabrade Air Power Tools are designed to operate at 90 PSIG (6.2 Bar/620 kPa) maximum air pressure at the tool inlet, when the tool is running. Use recommended regulator to control air pressure.

- Ideally the air supply should be free of moisture. To facilitate removing moisture from air supply, the installation of a refrigerated air dryer after the compressor and the use of drain valves at each tool station is recommended.

# Maintenance Instructions

**Important:** A Preventative Maintenance Program is recommended whenever portable power tools are used. The program should include inspection of air supply lines, air line pressure, proper lubrication and repair of tools. Refer to ANSI B186.1 for additional maintenance information.

- Use only genuine Dynabrade replacement parts to insure quality. To order replacement parts, specify **Model#**, **Serial#** and **RPM** of your air tool.
- It is strongly recommended that all Dynabrade rotary vane air tools be used with a Filter-Regulator-Lubricator to minimize the possibility of misuse due to unclean air, wet air or insufficient lubrication. Dynabrade recommends the following: **11405** Air Filter-Regulator-Lubricator (FRL) – Provides accurate air pressure regulation and two stage filtration of water contaminants. Operates 40 SCFM/1,133 LPM @ 100 PSIG with 3/8" NPT female ports.
- Dynabrade recommends one drop of air lube per minute for each 20 SCFM (example: if the tool specification states 40 SCFM, set the drip rate on the filter-lubricator to 2 drops per minute). Dynabrade Air Lube (P/N **95842**: 1 pt 473 ml) is recommended.

## Routine Preventative Maintenance:

- Check free speed of HiVac Dynorbital-Spirit® using a tachometer on a regular basis.
- BEFORE MOUNTING AN ACCESSORY, after all tool repairs and whenever a HiVac Dynorbital-Spirit® is issued for use, check tool RPM (speed) with tachometer with air pressure set at 90 PSIG while the tool is running. If tool is operating at a higher speed than the RPM marked on the tool housing, or operating improperly, the tool must be serviced and corrected for use.
- Mineral spirits are recommended when cleaning the tool and parts. Do not clean tool or parts with any solvents or oils containing acids, esters, ketones, chlorinated hydrocarbons or nitro carbons.
- DO NOT clean or maintain tools with chemicals that have a low flash point (example: WD-40®).
- A Drop-In Motor and Tune-Up Kit are available, see specific kit number on page 8.
- Air tool stampings must be kept legible at all times, if not, reorder and replace. User is responsible for maintaining specification information i.e.: Model #, S/N, and RPM.
- Blow air supply hose out prior to initial use.
- Visually inspect air hoses and fittings for frays, visible damage and signs of deterioration. Replace damaged or worn components.
- Refer to Dynabrade's Warning/Safety Operating Instructions Tag (Reorder No. **95903**) for safety information.

After maintenance is performed on tool, add a few drops of Dynabrade Air Lube (P/N **95842**) to the air line and start the tool a few times to lubricate air motor. Check for excessive tool vibration.

## Handling and Storage:

- Protect tool inlet from debris (See Notice Below).
- DO NOT carry tool by air hose.
- Protect abrasive accessories from exposure to water, solvents, high humidity, freezing temperature and extreme temperature changes.
- Store accessories in protective racks or compartments to prevent damage.

## Notice

All Dynabrade motors use the highest quality parts and materials available and are machined to exacting tolerances. The failure of quality pneumatic motors can most often be traced to an unclean air supply or the lack of lubrication. Air pressure easily forces dirt or water contained in the air supply into motor bearings causing early failure. It often scores the cylinder walls and the rotor blades resulting in limited efficiency and power. Our warranty obligation is contingent upon proper use of our tools and cannot apply to equipment which has been subjected to misuse such as unclean air, wet air or a lack of lubrication during the use of this tool.

# HiVac Dynorbital-Spirit®

## Complete Assembly

**For Models:**

59115, 59116, 59117, 59118

KEY	
<b>O</b>	Oil: O <sub>1</sub> = Air Lube
<b>A</b>	Adhesive: A <sub>2</sub> = Loctite #271 A <sub>8</sub> = Loctite #567
<b>T</b>	Torque: N·m x 8.85 = In. - lbs.

**Index Key**

No.	Part #	Description
-----	--------	-------------

1	56144	3" Vacuum Pad
2	59281	Shroud
3	59058	Lock Ring
4	50659	O-Ring
5	57069	Balancer Shaft
6	95630	Snap Ring
7	59084	V-Seal
8	56052	Bearing
9	59282	3/16" Motor Shaft Balancer
	59283	3/32" Motor Shaft Balancer
10	56047	Key
11	59057	"Top Hat" Seal
12	59083	Felt
13	58368	Bearing (2)
14	59077	Rear Bearing Plate
15	57113	Rotor/Blade Set
16	01024	O-Ring
17	59051	Cylinder
18	59076	Front Bearing Plate
19	98463	Retaining Ring
20	95697	Retaining Ring
21	<b>Housing</b>	
	59286	Model - 59115
	59287	Model - 59116
	59288	Model - 59117
	59289	Model - 59118
22	59291	Throttle Lever - 3/16"
	59292	Throttle Lever - 3/32"
23	98927	Pin
24	98459	O-Ring
25	58363	Valve Stem
26	59075	Speed Regulator
27	01025	O-Ring (2)
28	01464	Seal
29	58365	Tip Valve
30	01468	Spring
31	01494	Inlet Bushing
32	57083	Vacuum Adapter
33	96197	Dowel Pin
34	57066	Muffler Body
35	95526	O-Ring
36	59088	Vac Nozzle
37	57067	Vac Tube
38	57942	Vac Tube
39	57093	Vacuum Adapter
40	56027	Muffler Insert (2)
41	56028	Muffler Cap
42	59273	Muffler Assembly

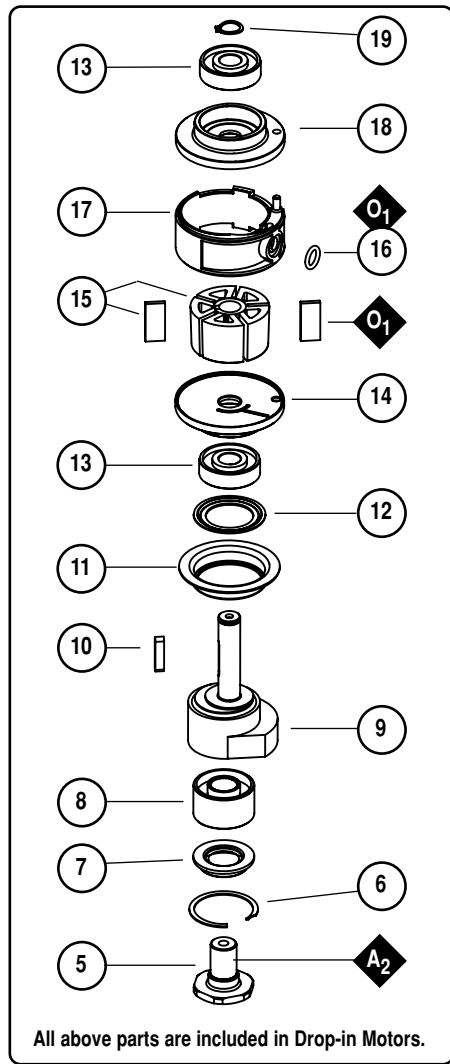
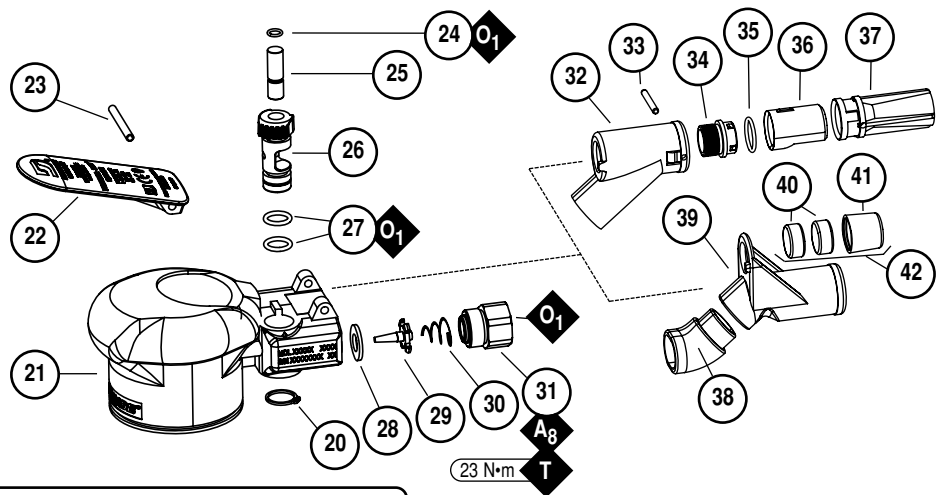

**Highly Recommended**  
Drop-in Complete Motor Assemblies

Orbit	3"
3/16"	59483
3/32"	59484

For assembly instructions, see page 6.

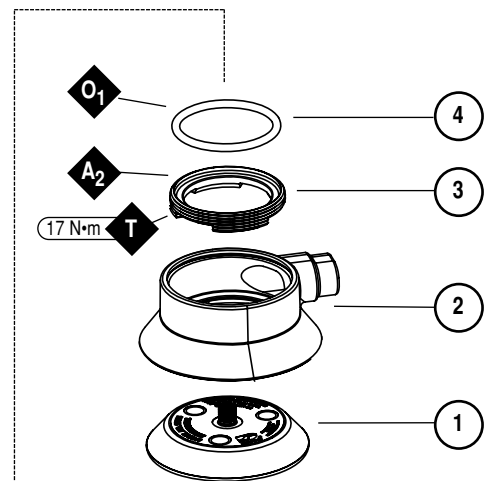

**Note:** To order replacement parts specify the Model # and Serial # of your machine.

# Motor Assembly/Disassembly Instructions - HiVac Dynorbital-Spirit®

**Important: Manufacturers warranty is void if tool is disassembled before warranty expires.**

A Full Service Repair Kit P/N 57098, is available which includes special repair tools for correct disassembly/assembly of the sander.

## To Disassemble:

1. Disconnect sander from air supply.
2. Invert the sander, and place the 57092 Repair Collar (supplied in the 57098 Full Service Repair Kit) around the housing and secure in a vise. Padding can be used on the vise jaws to protect the housing. **Important:** Do not over tighten the sander in the vise. If the sander is held too tight the removal of the lock ring and air motor will be difficult.
3. Remove sanding pad with the 50679 26mm Open-end Wrench (supplied with the sander), then remove 59281 Shroud.
4. Insert 56058 Lock Ring Tool (supplied in 57098 Full Service Repair Kit) into the corresponding tabs of lock ring. Loosen the 59058 Lock Ring turning it counterclockwise.
5. Remove the 59058 Lock Ring and the 50659 O-Ring from the air motor assembly.
6. Remove 01024 O-Ring and 98463 Retaining Ring from motor assembly.
7. Fasten a 2 in. bearing separator (P/N 96346 available) around the 59051 Cylinder just below the 59077 Rear Bearing Plate. Place the air motor assembly in a #2 arbor press (P/N 96232 available) so that the separator is resting on the table of the arbor press and with the balancer pointing down.
8. Use a flat nose 3/16" dia. drive punch as a press tool. Place it against the small end of the motor shaft balancer and push the shaft out of the upper 58368 Bearing.
9. Remove the rotor, vanes and rotor key from the motor shaft balancer.
10. Again fasten the 2 in. bearing separator between 58368 Bearing and the top of the balancer. Rest the separator on the table of the arbor press and push the motor shaft balancer out of the 58368 Bearing. Remove 59057 "Top Hat" Seal and 59083 Felt from 59076 Front Bearing Plate.
11. Disassemble the balancer assembly as follows:
  - a.) Place motor shaft balancer assembly into a soft jaw vise. Using a thin screwdriver, pick out the end of 95630 Snap Ring and remove. This will loosen the balancer assembly.
  - b.) Screw the threaded portion of the 56056 Bearing Puller (supplied in 57098 Repair Kit) into the 57069 Balancer Shaft and heat the outside of the motor shaft balancer to approximately 200° F (approximately 10 seconds with a propane torch). Now, using the slider weight, pull the assembly out.
  - c.) Press off 56052 Bearing with a bearing separator and arbor press, remove 59084 V-Seal.
12. If during step 11, the 56052 Bearing remains in the motor shaft balancer, it can be removed by the heating the shaft balancer again and using either an inside bearing puller or a blind hole bearing puller.

## To Assemble:

**Important:** Clean and inspect all parts for defects before assembling.

1. Assemble the balancer assembly as follows:
  - a.) Install 59084 V-Seal onto the balancer shaft. Install with flexible lip of seal facing hex of balancer shaft. Be certain seal is pressed completely over shaft step. See **Drawing 1**.
  - b.) Install 95360 Snap Ring between flange of 59084 V-Seal and hex of balancer shaft.
  - c.) Apply 1 drop of #271 Loctite® (or equivalent) and spread over several places around inside diameter of 56052 Bearing and the outside diameter of the 57069 Balancer Shaft.
  - d.) Use the 57091 Bearing Press Tool to press 56052 Bearing with seal side toward hex of balancer shaft up to shaft step as shown in **Drawing 1**. This is a firm press fit for proper retention of bearing.
2. Place the motor shaft balancer in a soft aluminum or bronze jaw vise with large end pointing up.
3. Apply 1 drop of #271 Loctite® (or equivalent) and spread over several places around the outside diameter of the 56052 Bearing and slide balancer assembly into the motor shaft balancer until 56052 Bearing is firmly seated at bottom. Squeeze 95630 Snap Ring into groove in motor shaft balancer to complete the assembly. Remove from vise.
4. Place the 59083 Felt into the 59057 "Top Hat" Seal.
5. Install the felt and the "Top Hat" Seal onto the motor shaft balancer so that they are centered as is shown in **Drawing 2**.
6. Use the small end of the 57091 Bearing Press Tool and the 96232 Arbor Press to install the 58368 Bearing onto the motor shaft balancer as shown in **Drawing 3**.
7. Install the 59076 Front Bearing Plate onto the motor shaft balancer, fitting it to the bearing, felt, and "Top Hat" Seal as is shown in **Drawing 4**.
8. Install the rotor key and the rotor onto the motor shaft balancer.
9. Lubricate the 56073 Vanes with the 95842 Dynabrade Air Lube (10W/NR or equivalent) and install them into the rotor.
10. Install the 59051 Cylinder so that the short line-up pin fits into the front bearing plate.

(continued on next page)

**Drawing 1**

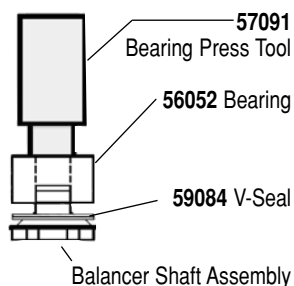

**Drawing 2**

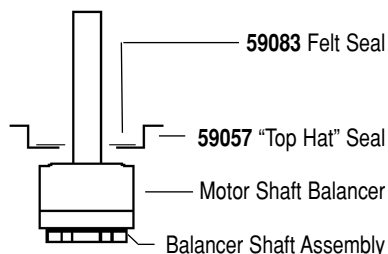

# Motor Assembly/Disassembly Instructions - HiVac Dynorbital-Spirit®

**Drawing 3**

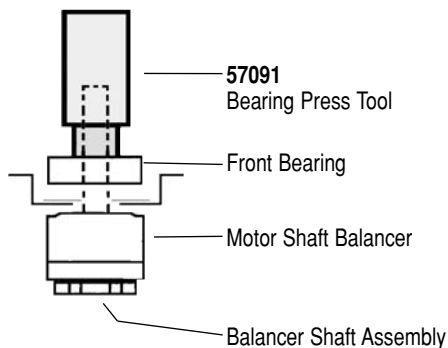

**Drawing 4**

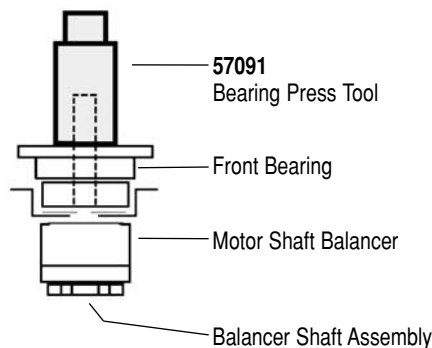

## To Assemble (Continued):

11. Install the **58368** Bearing into the **59077** Rear Bearing Plate.
12. Use the small end of the **57091** Bearing Press Tool and the arbor press to install the rear bearing/plate onto the motor shaft balancer as is shown in **Drawing 5**. Press the bearing/plate down until it touches the cylinder. This should create a snug fit between the bearing plates and cylinder.
13. Install the **01024** O-Ring into the cylinder and apply a small amount of the Dynabrade Air Lube onto the o-ring.
14. Coat the **50659** O-Ring with the Dynabrade Air Lube and install it into the **59058** Lock Ring. Slip these over the counter weight.
15. Place a mark on the edge of the motor opening to identify the location of the line-up notch on the inside of the housing.
16. Install the motor assembly into the housing. Be certain that the line-up pin enters the notch in the housing.
17. Use the **57092** Collar to carefully hold the tool in a vise so that the counter balance is pointing up.
18. Use the **56058** Lock Ring Tool to tighten the **59058** Lock Ring by turning it clockwise. (Torque to 17 N•m/150 in.- lbs.)
19. Snap **59281** Shroud onto flange of housing.
20. Use the 26mm open-end wrench to install a weight-mated sanding pad.

## Valve and Speed Regulator Assemblies:

1. Secure housing in vice using **57092** Collar or padded jaws.
2. Remove inlet bushing, **01468** Spring, **58365** Tip Valve and **01464** Seal from housing. Remove **98927** Pin from housing and lever.
3. Remove **95697** Snap Ring. Press the speed regulator and valve stem out of the housing. Remove the **01025** O-Rings (2) and **98459** O-Ring.
4. Place new **01025** O-Rings (2) on the speed regulator and a new **98459** O-Ring on the valve stem. Then place in housing with valve stem. Install new **95967** Snap Ring. Apply a small amount of pneumatic tool oil to valve o-rings.
5. Place new **01464** Seal in housing. Using tweezers or needle nose pliers, place the tip valve into housing so that the tip valve goes under the valve stem. Place new **01468** Spring into housing so small end is towards tip valve.
6. Apply a small amount of #567 Loctite® (or equivalent) around the threads of the first inlet bushing and tighten into housing to 23 N•m/200 in.-lbs.
7. Install Lever on housing with **98927** Pin centered on housing.

**Note:** Motor should operate at between 11,000 and 12,000 RPM at 6.2 bar (90 PSIG). RPM should be checked with a tachometer. Before operating, we recommend that 2-3 drops of Dynabrade Air Lube P/N **95842** (or equivalent) be placed directly into the air inlet with throttle lever depressed. Operate the machine for approximately 30 seconds before application to workpiece to determine if machine is working properly and safely and to allow lubricating oils to properly dispense through machine.

Loctite® is a registered trademark of the Loctite Corp.

## Disc Pad Change:

1. Insert **50679** Wrench on flats of **57069** Balancer Shaft and twist off sanding pad by hand.
2. With wrench still in place, hand tighten new pad on tool.
3. No need to remove shroud or overskirt.

## Required Weight of Pads:

3" Models — Use pad weighing 35g.

**Drawing 5**

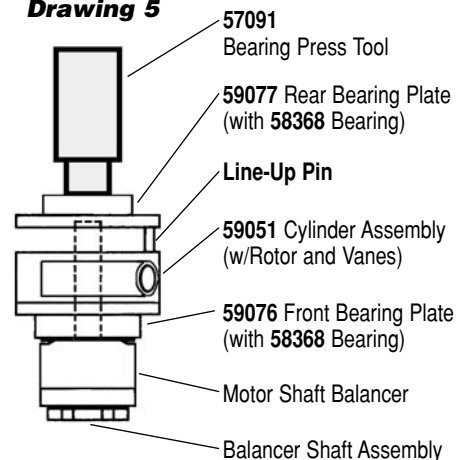

# Preventative Maintenance Schedule

For All HiVac Dynorbital-Spirit® Sanders

This service chart is published as a guide to expectant life of component parts. The replacement levels are based on average tool usage over one year. Dynabrade Inc. considers one year usage to be 1,000 hours or 50% of a man year.

## Parts Common to all Models:

LEGEND	
<b>T</b>	Included in Tune-Up Kit.
<b>X</b>	Type of wear, no other comments apply.
<b>L</b>	Easily lost. Care during assembly/disassembly.
<b>D</b>	Easily damaged during assembly/disassembly.
<b>R</b>	Replace each time tool is disassembled.



### 96510 Tune-Up Kit

Includes assorted parts to help maintain and repair motor.

Index #	Part Number	Description	Number Required	High Wear 100%	Medium Wear 70%	Low Wear 30%	Non-Wear 10%
1	56144	3" Vacuum Pad	1				X
2	59281	Shroud	1				
3	59058	Lock Ring	1			X	
4	50659	O-Ring	1			X	
5	57069	Balancer Shaft	1				X
6	95630	Snap Ring	1			L	
7	59084	V-Seal	1		T		
8	56052	Bearing	1		T		
9	See Note	Motor Shaft Balancer	1				X
10	56047	Key	1		T		
11	59057	"Top Hat" Seal	1			X	
12	59083	Felt	1		T		
13	58368	Bearing	2		T		
14	59077	Rear Bearing Plate	1			X	
15	57113	Rotor/Blade Set	1	T			
16	01024	O-Ring	1		T		
17	59051	Cylinder	1			X	
18	59076	Front Bearing Plate	1			X	
19	98463	Retaining Ring	1		T		
20	95697	Retaining Ring	1		T		
21	See Note	Housing	1				X
22	See Note	Throttle Lever	1			X	
23	98927	Pin	1		T		
24	98459	O-Ring	1		T		
25	58363	Valve Stem	1		T		
26	59075	Speed Regulator	1		T		
27	01025	O-Ring	2		T		
28	01464	Seal	1		T		
29	58365	Tip Valve	1		T		
30	01468	Spring	1		T		
31	01494	Inlet Bushing	1				X
32	57083	Vacuum Adapter	1			X	
33	96197	Dowel Pin	1			L	
34	57066	Muffler Body	1			X	
35	95526	O-Ring	1		T		
36	59088	Vac Nozzle	1			D	
37	57067	Vac Tube	1			X	
38	57942	Vac Tube	1			X	
39	57093	Vacuum Adapter	1			X	
40	56027	Muffler Insert	2	T			
41	56028	Muffler Cap	1		T		

**Note:** Please refer to page 4 of tool manual for specific part number.

# Machine Specifications

## 3/16" Orbit Models

Model Number	Motor hp (W)	Motor RPM	Dia. Orbit Inch (mm)	Sound Level	Air Flow Rate CFM/SCFM (LPM)	Air Pressure PSIG (Bars)	Spindle Thread	Weight Pound (kg)	Length Inch (mm)	Height Inch (mm)
59115	.25 (186)	12,000	3/16" (5)	84 dB(A)	2/16 (453)	90 (6.2)	5/16"-24 female	1.3 (0.6)	7-3/4 (197)	3-3/4 (95)
59117	.25 (186)	12,000	3/16" (5)	82 dB(A)	2/16 (453)	90 (6.2)	5/16"-24 female	1.3 (0.6)	6-1/2 (165)	3-3/4 (95)

## 3/32" Orbit Models

Model Number	Motor hp (W)	Motor RPM	Dia. Orbit Inch (mm)	Sound Level	Air Flow Rate CFM/SCFM (LPM)	Air Pressure PSIG (Bars)	Spindle Thread	Weight Pound (kg)	Length Inch (mm)	Height Inch (mm)
59116	.25 (186)	12,000	3/32" (2)	84 dB(A)	2/16 (453)	90 (6.2)	5/16"-24 female	1.3 (0.6)	7-3/4 (197)	3-3/4 (95)
59118	.25 (186)	12,000	3/32" (2)	82 dB(A)	2/16 (453)	90 (6.2)	5/16"-24 female	1.3 (0.6)	6-1/2 (165)	3-3/4 (95)

Additional Specifications: Air Inlet Thread 1/4" NPT • Hose I.D. Size 1/4" or 8mm

Sound Level is the pressure measurement according to the method outlined in ISO regulation ISO-15744

# Optional Accessories



### Drop-in Motors

Allows a quick and easy replacement. No motor adjustments needed.

59483 – 3" Dia., 3/16" Orbit

59484 – 3" Dia., 3/32" Orbit

### Complete Repair Solution

Includes: 10 Pack of Drop-in Motors  
59459 Repair Kit



### 59459 Drop-in Motor Repair Kit:

Includes special tools for proper disassembly/assembly of the Dynorbital-Spirit® drop-in motor.

Includes: 57092 Repair Collar  
56058 Lock Ring Wrench



### 96510 Tune-Up Kit

Includes assorted parts to help maintain and repair motor.



### 59293 26mm

Offset Open-End Wrench



### 57098 Full Service Repair Kit:

Includes special tools for proper disassembly/assembly of the HiVac Dynorbital-Spirit®.

Includes: 57092 Repair Collar  
56058 Lock Ring Wrench  
56056 Bearing Puller  
57091 Bearing Press Tool  
57099 Bearing Puller  
96034 12mm Hex Wrench

### Dust Collection Systems

Dynabrade offers a wide variety of Dust Collection Systems. A complete offering of possibilities are described in our Accessories Catalog as well as our Complete Catalog.



### Abrasives

Dynabrade offers a wide variety of 3" HiVac Dynorbital-Spirit® specific abrasives. A complete offering of possibilities are described in our 3" HiVac Dynorbital-Spirit® Literature.

