

Models:

- 58441** - 5" Pad, Non-Vac, Hook-Face Pad
- 58442** - 6" Pad, Non-Vac, Vinyl Pad
- 58443** - 6" Pad, Central Vac, Vinyl Pad
- 58444** - 6" Pad, Central Vac, Hook-Face Pad
- 58445** - 8" Pad, Non-Vac, Hook-Face Pad
- 58446** - 8" Pad, Central Vac, Vinyl Pad
- 58447** - 8" Pad, Central Vac, Vinyl Pad



3/16" Orbit Two-Hand Gear Driven Sander

900 RPM Air Motor and Machine Parts

WARNING

Always operate, inspect and maintain this tool in accordance with the Safety Code for portable air tools (ANSI B186.1) and any other applicable safety codes and regulations. Please refer to Dynabrade's Warning/Safety Operating Instructions for more complete safety information.

Index Key

No.	Part #	Description
1	95178	Screw (5)
2	95886	Washer (5)
3	Sanding Pad:	See Chart
4	96477	Screw
5	Balance Arm Assembly:	
	56476	5" & 6"
	56478	8"
6	56474	Balancer Washer
7	56470	Mount Plate Assembly (Includes Items 7-11)
8	56472	Gear
9	96429	Screw (3)
10	96428	Screw (5)
11	96423	Bearing
12	Shroud:	
	57328	Non-Vacuum
	57744	6" Vacuum Overskirt
	57736	8" Vacuum Overskirt
13	01673	Pin
14	56589	Shaft
15	54673	Key
16	56133	Bearing
17	56473	Pinion Gear
18	57332	Lock Ring
19	96166	Set Screw
20	56594	Front Bearing Plate
21	54705	Rotor/Blade Set (5/pkg.)
22	56495	Cylinder (Includes: 95865 & 96313 Pin)
23	95911	O-Ring
24	54629	Rear Bearing Plate
25	01206	Bearing
26	95626	Retaining Ring
27	Housing:	See Chart (Includes: 56581 Housing Grip and Labels)
28	95627	Pin
29	56582	Safety Throttle Lever
30	98459	O-Ring
31	56579	Valve Stem
32	56578	Speed Regulator
33	01025	O-Ring (3)
34	56598	Seal
35	51944	Tip Valve
36	51943	Spring
37	56586	Vacuum Plug
38	56469	Exhaust Gasket
39	96459	O-Ring
40	56468	Handle Assembly (Includes: 51938 Screen)
41	96469	Screw (2)
42	96454	Screw (2)
43	56597	Muffler
44	56596	Muffler Clip

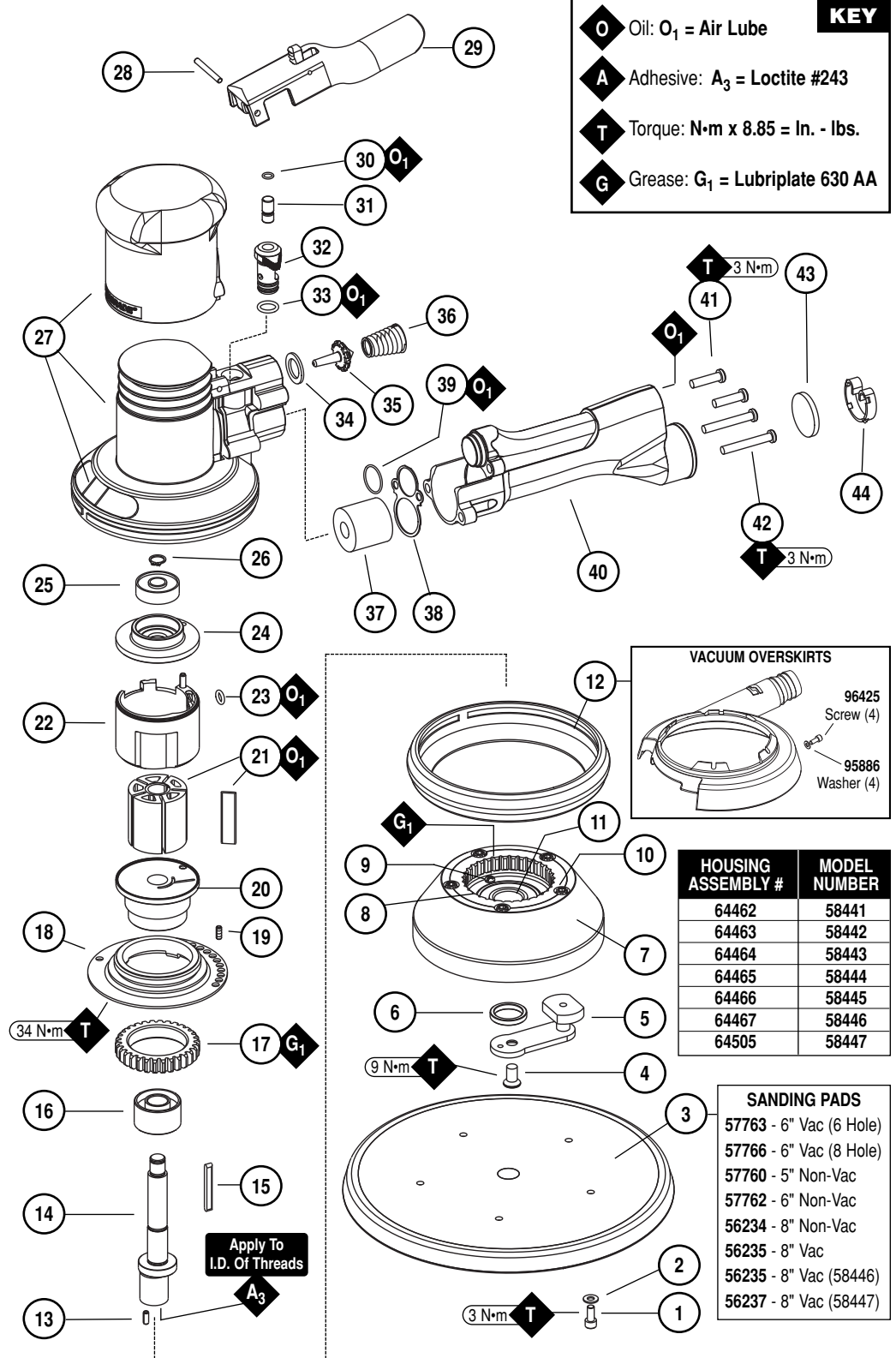

KEY

- O** Oil: O₁ = Air Lube
- A** Adhesive: A₃ = Loctite #243
- T** Torque: N·m x 8.85 = In. - lbs.
- G** Grease: G₁ = Lubriplate 630 AA

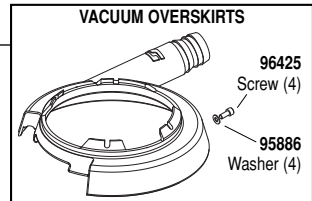

HOUSING ASSEMBLY #	MODEL NUMBER
64462	58441
64463	58442
64464	58443
64465	58444
64466	58445
64467	58446
64505	58447

SANDING PADS

57763	- 6" Vac (6 Hole)
57766	- 6" Vac (8 Hole)
57760	- 5" Non-Vac
57762	- 6" Non-Vac
56234	- 8" Non-Vac
56235	- 8" Vac
56235	- 8" Vac (58446)
56237	- 8" Vac (58447)

Important Operating, Maintenance and Safety Instructions

Carefully read all instructions before operating or servicing any Dynabrade® Abrasive Power Tool.

Warning: Hand, wrist and arm injury may result from repetitive work motion and overexposure to vibration.

Important: All Dynabrade rotary vane air tools must be used with a Filter-Regulator-Lubricator to maintain all warranties.

Operating Instructions:

Warning: Eye, face, respiratory, sound and body protection must be worn while operating power tools. Failure to do so may result in serious injury or death. Follow safety procedures posted in workplace.

1. With power source disconnected from tool, securely fasten abrasive/accessory on tool.
2. Install air fitting into inlet bushing of tool. **Important:** Secure inlet bushing of tool with a wrench before attempting to install the air fitting to avoid damaging valve body housing.
3. Connect power source to tool. Be careful not to depress throttle lever in the process.
4. Air tools are not intended for use in explosive atmospheres and are not insulated for contact with electrical power sources. Sanding/Grinding certain materials can create explosive dust. It is the employers responsibility to notify the user of acceptable dust levels. Sanding/Grinding can cause sparks which can cause fires or explosions. It is the users responsibility to make sure the work area is free of flammable materials.

Maintenance Instructions:

1. Check tool speed regularly with a tachometer. If tool is operating at a higher speed than the RPM marked on the tool, the tool should be serviced to correct the cause before use.
2. Some silencers on air tools may clog with use. Clean and replace as required.
3. All Dynabrade rotary vane air motors should be lubricated. Dynabrade recommends one drop of air lube per minute for each 20 SCFM (example: if the tool specifications state 40 SCFM, set the drip rate of your filter-lubricator at 2 drops per minute). Dynabrade Air Lube (P/N 95842: 1 pt. 473 ml.) is recommended.
4. It is strongly recommended that all Dynabrade rotary vane air tools be used with a Filter-Regulator-Lubricator to minimize the possibility of misuse due to unclear air, wet air or insufficient lubrication. Dynabrade recommends the following: **10690** Air Line Filter-Regulator-Lubricator — Provides accurate air pressure regulation, two-stage filtration of water contaminants and micro-mist lubrication of pneumatic components. Operates 40 SCFM @ 100 PSIG has 3/8" NPT female ports.
5. Use only genuine Dynabrade replacement parts. To reorder replacement parts, specify the **Model #**, **Serial #**, and **RPM** of your machine.
6. A Motor Tune-Up Kit (P/N 98221) is available which includes assorted parts to help maintain motor in peak operating condition. Please refer to Dynabrade's Preventative Maintenance Schedule for a guide to expectant life of component parts.
7. Mineral spirits are recommended when cleaning the tool and parts. Do not clean tool or parts with any solvents or oils containing acids, esters, keytones, chlorinated hydrocarbons or nitro carbons.
8. DO NOT clean or maintain air tools with chemicals that have a low flash point (example: WD-40®).
9. Use the 95541 Grease Gun to apply 2 full plunges of the 95544 Grease through the grease fitting that is located in the 56470 Mount Plate Assembly. Two full plunges of grease should be applied after every 300-hour interval of use.

Safety Instructions:

Products offered by Dynabrade should not be converted or otherwise altered from original design without expressed written consent from Dynabrade, Inc.



- **Important:** User of tool is responsible for following accepted safety codes such as those published by the American National Standards Institute (ANSI).
- Always disconnect power supply before changing abrasive/accessory or making machine adjustments.
- Inspect abrasives/accessories for damage or defects prior to installation on tools.
- Please refer to Dynabrade's Warning/Safety Operating Instructions Tag (Reorder No. 95903) for more complete safety information.

Notice

All Dynabrade motors use the highest quality parts and metals available and are machined to exacting tolerances. The failure of quality pneumatic motors can most often be traced to an unclean air supply or the lack of lubrication. Air pressure easily forces dirt or water contained in the air supply into motor bearings causing early failure. It often scores the cylinder walls and the rotor blades resulting in limited efficiency and power. Our warranty obligation is contingent upon proper use of our tools and cannot apply to equipment which has been subjected to misuse such as unclean air, wet air or a lack of lubrication during the use of this tool.

Machine Specifications

Model Number	Motor hp (W)	Motor RPM	Pad Dia. Inch (mm)	Sound Level	Maximum Air Flow CFM/SCFM (LPM)	Hose I.D. Size Inch (mm)	Air Inlet Thread	Weight Pound (kg)	Length Inch (mm)	Height Inch (mm)
58441	.45 (336)	900	5 (127)	79 dB(A)	3/23 (651)	1/4 (8)	1/4" NPT	3.6 (1.7)	11-1/16 (281)	5-10/16 (143)
58442	.45 (336)	900	6 (152)	78 dB(A)	3/23 (651)	1/4 (8)	1/4" NPT	3.6 (1.7)	11-1/2 (293)	5-5/8 (141)
58443	.45 (336)	900	6 (152)	79 dB(A)	3/23 (651)	1/4 (8)	1/4" NPT	3.8 (1.7)	11-1/2 (293)	5-5/8 (141)
58444	.45 (336)	900	6 (152)	80 dB(A)	3/23 (651)	1/4 (8)	1/4" NPT	3.8 (1.7)	11-1/2 (293)	5-5/8 (141)
58445	.45 (336)	900	8 (203)	80 dB(A)	3/23 (651)	1/4 (8)	1/4" NPT	3.9 (1.8)	12-1/2 (319)	5-9/16 (142)
58446	.45 (336)	900	8 (203)	81 dB(A)	3/23 (651)	1/4 (8)	1/4" NPT	4.3 (2.0)	12-1/2 (319)	5-9/16 (142)
58447	.45 (336)	900	8 (203)	81 dB(A)	3/23 (651)	1/4 (8)	1/4" NPT	4.3 (2.0)	12-1/2 (319)	5-9/16 (142)

Additional Specifications: Air Pressure 90 PSIG (6.2 Bar)

Disassembly/Assembly Instructions

Important: The manufacturer's warranty is void if the tool is disassembled before the warranty expires. Use these instructions in conjunction with the Part Number 96283 Tool Repair Kit. This kit includes special tooling for the proper disassembly/assembly of the Two-Hand Gear Driven Sander. This Tooling will be referred to in these instructions. An air motor Tune-Up Kit, Part Number 98221 is also available. It contains the high and medium wear components that most commonly need replacement.

Motor Disassembly:

1. Disconnect the sander from the air supply.
2. Use the **57092** Repair Collar to hold the sander in a vise. Position the sander so that the sanding pad is facing up. **Note:** Do not over tighten the collar and sander in the vise. Only hold the sander snugly, so that the motor lock ring can be removed easily.
3. Use a 9/64" hex key wrench to remove the screws and sanding pad from the sander.
4. Use a 5/32" hex key wrench to remove the balance arm assembly by turning the hex key counterclockwise.
5. Remove the **56474** Balance Washer and **56470** Mount Plate Assembly. Use a 2mm hex key to remove the **96166** Set Screw.
6. Use the **56599** Lock Ring Tool to remove the **57332** Lock Ring by turning it counterclockwise.
7. Pull the air motor assembly out of the housing.
8. Use retaining ring pliers to remove the **95626** Retaining Ring.
9. Remove the **95911** O-Ring from the **56495** Cylinder and fasten a 2" bearing separator around the part of the cylinder that is closest to the **54629** Rear Bearing Plate.
10. Place the air motor with the bearing separator attached, onto the table of the **96232**, #2 Arbor Press so that the balance end of the **56589** Shaft is pointing down.
11. Use a 5/16" dia. flat end drive punch as a press tool to push the shaft out of the **01206** Bearing. Use the **96213** Bearing Removal Tool (bearing removal tool not included in the **96283** Repair Kit) to push the **01206** Bearing out of the **54629** Rear Bearing Plate.
12. Remove the cylinder, rotor, vanes, and key.
13. Use the arbor press to push **56133** bearing and the **56589** Shaft out of the **56594** Front Bearing Plate.
14. Use a 2" bearing separator and arbor press to remove the **56133** Bearing from the **56589** Shaft.
15. Use a 2" bearing separator and arbor press to remove the **56473** Pinion Gear from the **56594** Front Bearing Plate.

Motor Disassembly Complete.

Motor Assembly:

Important: Clean and inspect all motor parts for wear or defect.

1. Install **56133** Bearing on the balance end of the **56589** Shaft.
2. Use the small end of the **50791** Bearing Press Tool and the **96232**, #2 Arbor Press to push the **56133** Bearing onto the shaft until the I.D. of the bearing sits against the shaft step. (Drawing 1)
3. Install the **57332** Lock Ring onto the **56594** Front Bearing Plate so that the threaded portion of the lock ring sits against the bearing plate.
4. Use the arbor press to press the **56473** Pinion Gear onto the front bearing plate. Note: Press the pinion gear onto the bearing plate so that the edge of the bearing plate stands slightly above the pinion gear.
5. Use the large end of the **50791** Bearing press Tool and the arbor press to install the front bearing plate onto the **56133** Bearing. (Drawing 2)
6. Install the **54673** Key so that the 90° side of the key fits into the keyway of the shaft and the tapered side of the key fits into the rotor. Install the **54705** Rotor/Blade Set (5) onto the shaft
7. Apply the **95842** Dynabrade Air Lube (10W/NR or equivalent) to the blades.
8. Install the **56495** Cylinder over the rotor so that the short line-up pin fits into the front bearing plate.
9. Place the **54629** Rear Bearing Plate over the shaft so that the long line-up pin fits through the hole in the rear bearing plate. (Drawing 3) Use the small end of the **50791** Bearing Press Tool to install the **01206** Bearing onto the shaft and into the **54629** Rear Bearing Plate. Use the press tool and the arbor press to install these so that there is a snug fit between the bearing plates and the cylinder. **Note:** Carefully press the **01206** Bearing onto the motor shaft until it touches against the bearing seat on the inside of the bearing plate. (Drawing 4)
10. Use retaining ring pliers to install the **95626** Retaining Ring so that the concave side of the ring is toward the motor assembly. **Note:** Be sure that the retaining ring is completely pressed down into the groove on the shaft.
11. Use the **57092** Repair Collar to hold the housing in a vise so that the opening for the housing is facing up.
12. Apply a small amount of petroleum lubricant to the **95911** O-Ring and install the o-ring into the air inlet hole in the cylinder.
13. Install the motor assembly into the housing making sure to align the line-up pin with the line-up hole that is on the inside of the housing.
14. Use the **56599** Lock Ring Tool to secure the motor in the housing. (Torque to 34 N•m/300 in. lbs.)
15. Use a 2mm hex key and install set screw into the housing through one of the holes in the lock ring until set screw is flush with the top of the lock ring.
16. Install the appropriate shroud onto the housing.
17. Apply a small amount of the **95544** Grease to the mount plate gear and then install the **56470** Mount Plate Assembly and the **56474** Balance Washer onto the **56589** Shaft. Apply a small amount of the Loctite #243 (or equivalent) to the I.D. threads of the **56589** Shaft. Hold the balance arm assembly stationary with an adjustable wrench and use a 5/32" hex key to tighten the **96477** Screw by turning it clockwise. (Torque to 9N•m/80 in. lbs.)
18. Use the **95541** Grease Gun to apply 2 full plunges of the **95544** Grease through the grease fitting that is located in the **56470** Mount Plate Assembly. Two full plunges of grease should be applied after every 300-hour interval of use.
19. Use a 9/64" hex key wrench to install a weight-mated sanding pad.

Motor Assembly Complete.

Handle and Valve Disassembly:

1. Place the **57092** Repair Collar around the housing so that the handle is pointing up.
2. Use a Phillips screwdriver to remove the four screws that fasten the handle to the housing. Carefully pull the handle from the housing. This provides access to the tip valve components, also the handle o-ring, gasket and vacuum plug.
3. Use a 1/8" dia. flat end drive punch to remove the **95627** Pin and the **56582** Safety Throttle Lever.
4. Pull the **56578** Speed Regulator and valve stem out of the housing.

Handle and Valve Disassembly Complete.

Handle and Valve Assembly:

1. Place the **57092** Repair Collar around the housing so that the handle mounting area is facing up.
2. Install the **01025** O-Rings (3) onto the **56578** Speed Regulator, apply a small amount of petroleum lubricant to the o-rings and insert the regulator assembly into the housing. **Note:** Be careful that the o-rings do not get caught and pulled out of the o-ring grooves.

(continued text and diagrams on next page)

3. Install the **98459** O-Ring onto the **56579** Valve Stem, apply a small amount of petroleum lubricant to the o-ring and insert the shortest portion (from the end to the o-ring) of the valve stem assembly into the speed regulator.
4. Install the **56582** Safety Throttle Lever onto the housing and secure it in place with the **95627** Pin.
5. Install the **56598** Seal into the air inlet passage of the housing.
6. Install the **56586** Vacuum Plug into the exhaust passage of the housing. (See Exploded View)
7. Use needle-nose pliers to grasp and install the **51944** Tip Valve so that it fits under the **56579** Valve Stem.
8. Install the large end of the **51943** Spring into the air inlet passage of the handle.
9. Install the **56469** Gasket onto the mounting surface of the handle.
10. Install the **96459** O-Ring onto outside diameter of the air inlet passage at the location of the first shoulder and apply a small amount of petroleum lubricant to the o-ring.
11. Connect the handle to the housing and secure it in place with the four screws. Note: The two longer screws, Part Number **96454** (2) secure the **56581** Grip to the housing.
12. Install the **56597** Muffler and secure it in place with the **56596** Muffler Clip. (See Exploded View)

Handle and Valve Assembly Complete. Tool Assembly Complete. Please allow 30 minutes for adhesives to cure before operating tool.

Important: Motor should now be tested for proper operation at 90 PSIG. If motor does not operate properly or operates at a higher RPM than marked on the tool, the tool should be serviced to correct the cause before use. Before operating, place 2-3 drops of Dynabrade Air Lube (P/N **95842**) directly into air inlet with throttle lever depressed. Operate tool for 30 seconds to determine if tool is operating properly and to allow lubricating oils to properly penetrate motor.

Loctite® is a registered trademark of Loctite Corp.

Diagrams

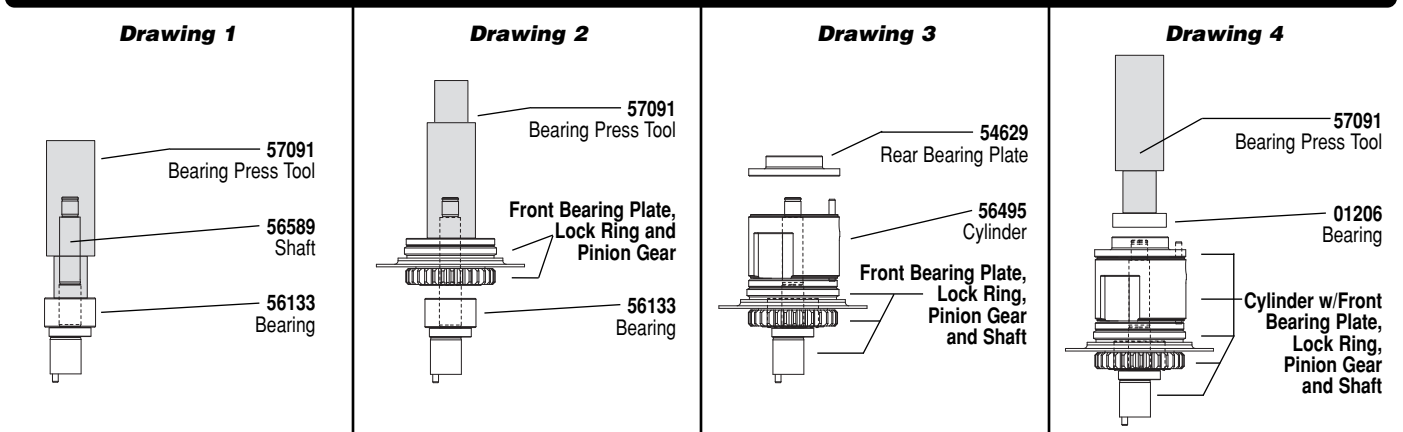

Optional Accessories



98221 Motor Tune-Up Kit

- Includes assorted parts to help maintain and repair motor.



96232 (#2) Arbor Press

- This arbor press is ideal for the disassembly and assembly of air motors.



96346 2" Bearing Separator

- Use the separator to remove gears and bearings.

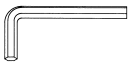

95134 – 9/64" Hex Wrench

95135 – 5/32" Hex Wrench

96401 – 2mm Hex Wrench



96343 Retaining Ring Pliers

- Internal/external retaining ring pliers.
Tip diameter - 0.038" (0.96mm)



Dynabrade Air Lube

- Formulated for pneumatic equipment.
 - Absorbs up to 10% of its weight in water.
 - Prevents rust and formation of sludge.
 - Keeps pneumatic tools operating longer with greater power and less down time.
- 95842:** 1 pt. (473 ml)
95843: 1 gal. (3.8 L)



96283 Motor Repair Kit:

- Contains special tools for disassembly/assembly of machine.

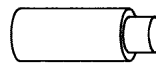

96213 Bearing Removal Tool

- This tool is used to pass through the I.D. of the bearing plate and to push against the I.D. of the bearing.

