

Dynalocke™ Dual Action Sander

12,000 RPM, 3/16" Orbit Air Motor and Machine Parts

Models:

58430 - 5" Pad, Non-Vac
58431 - 5" Pad, Self Gen. Vac

58435 - 6" Pad, Non-Vac
58436 - 6" Pad, Self Gen. Vac

⚠ WARNING

Always operate, inspect and maintain this tool in accordance with the Safety Code for portable air tools (ANSI B186.1) and any other applicable safety codes and regulations. Please refer to Dynabrade's Warning/Safety Operating Instructions for more complete safety information.

Index Key

No.	Part #	Description
1		Sanding Pad: See Chart
2	57262	Balancer Shaft
3	95630	Snap Ring
4	59084	V-Seal
5	56133	Bearing
6		Motor Shaft Balancer:
	57268	5"
	57269	6"
7	54673	Key
8	56046	Lock Ring
9	59057	"Top Hat" Seal
10	59083	Felt
11	02695	Bearing
12	54630	Front Bearing Plate
13	54705	Rotor/Blade Set (5/pkg.)
14	56595	Cylinder (Includes: 95865 Pin)
15	01020	O-Ring
16	54629	Rear Bearing Plate
17	01206	Bearing
18	56713	Lock Assembly
19	96252	Compression Spring
20	56705	Post Cap
21	57264	Post Assembly
22	56712	Switch Bottom
23	96478	O-Ring
24	57369	Shroud
25		Housing: See Chart (Includes: 56591 Housing Grip and Labels)
26	56711	Switch Top
27	96489	Screw
28	95627	Pin
29	56582	Safety Throttle Lever
30	98459	O-Ring
31	56579	Valve Stem
32	56578	Speed Regulator
33	01025	O-Ring (3)
34	56598	Seal
35	51944	Tip Valve
36	51943	Spring
37	56586*	Vacuum Plug
38	96459	O-Ring
39	56469	Exhaust Gasket
40	56468	Handle Assembly (Includes: 51938 Inlet Screen)
41	96469	Screw (2)
42	96454	Screw (2)
43	56597*	Muffler
44	56596*	Muffler Cap

*Parts included with Non-Vacuum Models Only.

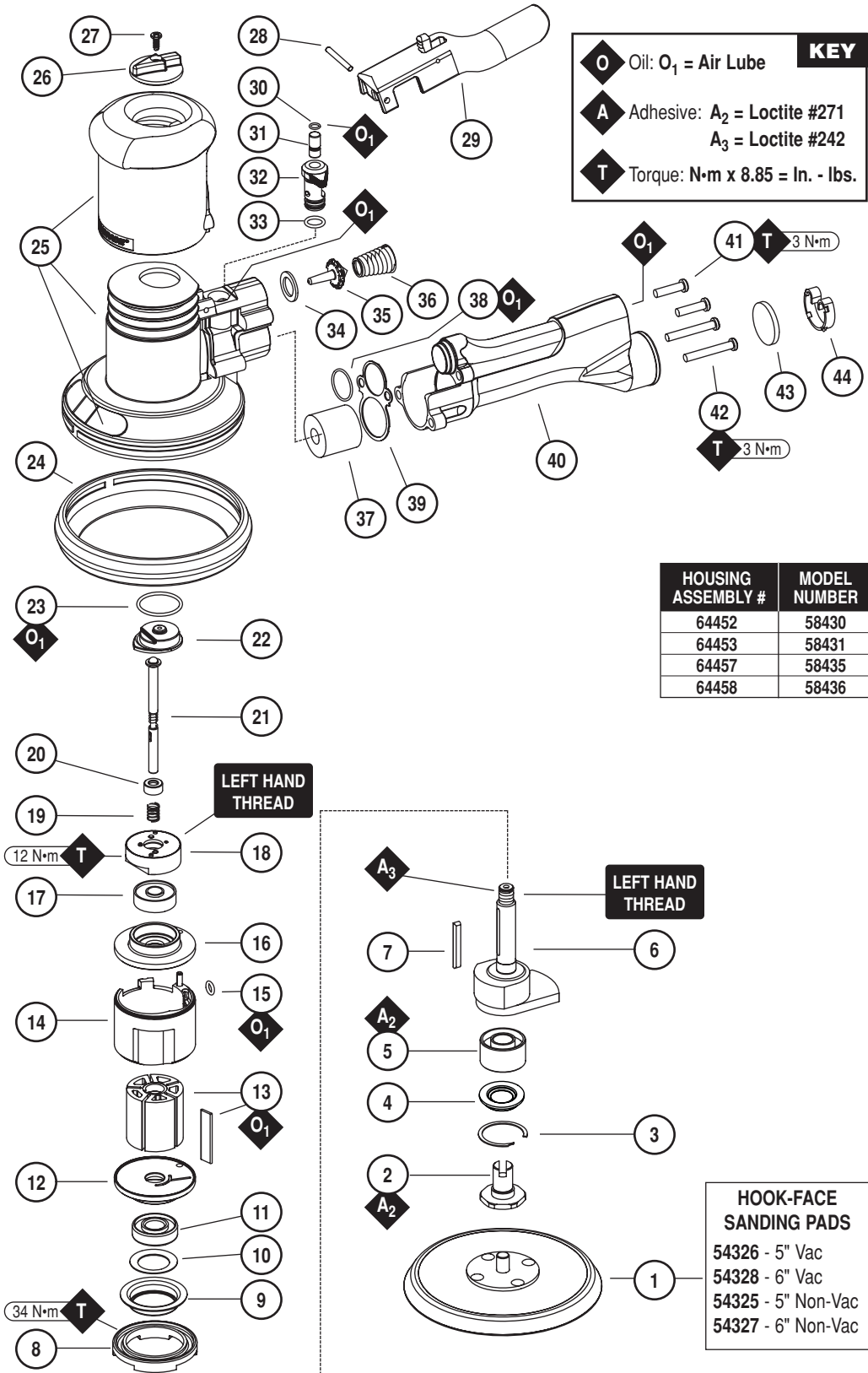

LEFT HAND THREAD

LEFT HAND THREAD

HOOK-FACE SANDING PADS

Important Operating, Maintenance and Safety Instructions

Carefully read all instructions before operating or servicing any Dynabrade® Abrasive Power Tool.

Warning: DO NOT USE pressure sensitive adhesive (PSA) abrasive products on this tool.

Warning: Hand, wrist and arm injury may result from repetitive work motion and overexposure to vibration.

Important: All Dynabrade Rotary Vane air tools must be used with a Filter-Regulator-Lubricator to maintain all warranties.

Operating Instructions:

Warning: Eye, face, respiratory, sound and body protection must be worn while operating power tools. Failure to do so may result in serious injury or death. Follow safety procedures posted in workplace.

1. With power source disconnected from tool, securely fasten abrasive/accessory on tool.
2. Install air fitting into inlet bushing of tool. **Important:** Secure inlet bushing of tool with a wrench before attempting to install the air fitting to avoid damaging valve body housing.
3. Connect power source to tool. Be careful not to depress throttle lever in the process.
4. Air tools are not intended for use in explosive atmospheres and are not insulated for contact with electrical power sources. Sanding/Grinding certain materials can create explosive dust. It is the employers responsibility to notify the user of acceptable dust levels. Sanding/Grinding can cause sparks which can cause fires or explosions. It is the users responsibility to make sure the work area is free of flammable materials.

Maintenance Instructions:

To keep tool safe a preventative maintenance program is recommended whenever portable power tools are used.

1. Check tool speed regularly with a tachometer. If tool is operating at a higher speed than the RPM marked on the tool, the tool should be serviced to correct the cause before use.
2. Some silencers on air tools may clog with use. Clean and replace as required.
3. All Dynabrade Rotary Vane air motors should be lubricated. Dynabrade recommends one drop of air lube per minute for each 20 SCFM (example: if the tool specifications state 40 SCFM, set the drip rate of your filter-lubricator at 2 drops per minute). Dynabrade Air Lube (P/N 95842: 1 pt. 473 ml.) is recommended.
4. It is strongly recommended that all Dynabrade rotary vane air tools be used with a Filter-Regulator-Lubricator to minimize the possibility of misuse due to unclear air, wet air or insufficient lubrication. Dynabrade recommends the following: **10681** Air Line Filter-Regulator-Lubricator — Provides accurate air pressure regulation, two-stage filtration of water contaminants and micro-mist lubrication of pneumatic components.
5. Use only genuine Dynabrade replacement parts. To reorder replacement parts, specify the **Model #**, **Serial #**, and **RPM** of your machine.
6. A Motor Tune-Up Kit (P/N 98220) is available which includes assorted parts to help maintain motor in peak operating condition. Please refer to Dynabrade's Preventative Maintenance Schedule for a guide to expectant life of component parts.
7. Mineral spirits are recommended when cleaning the tool and parts. Do not clean tool or parts with any solvents or oils containing acids, esters, ketones, chlorinated hydrocarbons or nitro carbons.
8. DO NOT clean or maintain air tools with chemicals that have a low flash point (example: WD-40®).

Safety Instructions:

Products offered by Dynabrade should not be converted or otherwise altered from original design without expressed written consent from Dynabrade, Inc.



- **Important:** User of tool is responsible for following accepted safety codes such as those published by the American National Standards Institute (ANSI).
- Always disconnect power supply before changing abrasive/accessory or making machine adjustments.
- Inspect abrasives/accessories for damage or defects prior to installation on tools.
- Please refer to Dynabrade's Warning/Safety Operating Instructions Tag (Reorder No. 95903) for more complete safety information.

Notice

All Dynabrade motors use the highest quality parts and metals available and are machined to exacting tolerances. The failure of quality pneumatic motors can most often be traced to an unclear air supply or the lack of lubrication. Air pressure easily forces dirt or water contained in the air supply into motor bearings causing early failure. It often scores the cylinder walls and the rotor blades resulting in limited efficiency and power. Our warranty obligation is contingent upon proper use of our tools and cannot apply to equipment which has been subjected to misuse such as unclear air, wet air or a lack of lubrication during the use of this tool.

Full One Year Warranty

Following the reasonable assumption that any inherent defect which might prevail in a product will become apparent to the user within one year from the date of purchase, all equipment of our manufacture is warranted against defects in workmanship and materials under normal use and service. We shall repair or replace at our factory, any equipment or part thereof which shall, within one year after delivery to the original purchaser, indicate upon our examination to have been defective. Our obligation is contingent upon proper use of Dynabrade tools in accordance with factory recommendations, instructions and safety practices. It shall not apply to equipment which has been subject to misuse, negligence, accident or tampering in any way so as to affect its normal performance. Normally wearable parts such as bearings, contact wheels, rotor blades, etc., are not covered under this warranty.

Model Number	Motor hp (W)	Motor RPM	Pad Dia. Inch (mm)	Sound Level	Maximum Air Flow SCFM (LPM)	Hose I.D. Size Inch (mm)	Air Inlet Thread	Tool Thread	Weight Pound (kg)	Length Inch (mm)	Height Inch (mm)
58430	.45 (336)	12,000	5 (127)	82 dB(A)	23 (651)	1/4 (6)	1/4" NPT	5/16"-24 Female	2.7 (1.2)	11-1/16 (280)	5-1/8 (131)
58431	.45 (336)	12,000	5 (127)	82 dB(A)	23 (651)	1/4 (6)	1/4" NPT	5/16"-24 Female	2.6 (1.2)	11-1/16 (280)	5-1/8 (131)
58435	.45 (336)	12,000	6 (152)	82 dB(A)	23 (651)	1/4 (6)	1/4" NPT	5/16"-24 Female	2.8 (1.3)	11-1/2 (293)	5-1/8 (131)
58436	.45 (336)	12,000	6 (152)	85 dB(A)	23 (651)	1/4 (6)	1/4" NPT	5/16"-24 Female	2.7 (1.2)	11-1/2 (293)	5-1/8 (131)

Additional Specifications: Air Pressure 90 PSIG (6.2 Bar)

Disassembly/Assembly Instructions

Important: The manufacturer's warranty is void if the tool is disassembled before the warranty expires. Use these instructions in conjunction with the Part Number 57260 Tool Repair Kit. This kit includes special tooling for the proper disassembly/assembly of the Two-Hand Dynalocke Sander. This Tooling will be referred to in these instructions. An air motor Tune-Up Kit, Part Number 98220 is also available. It contains the high and medium wear components that most commonly need replacement.

Motor Disassembly:

1. Disconnect the sander from the air supply.
2. Use the **57092** Repair Collar to hold the sander in a vise. Position the sander so that the sanding pad is facing up. **Note:** Do not over tighten the collar and sander in the vise. Only hold the sander snugly, so that the motor lock ring can be removed easily.
3. Use the **50679** 26mm Open End Wrench to remove the sanding pad from the sander by holding the **57262** Balancer Shaft stationary and turning the pad counterclockwise.
4. Use the **56058** Lock Ring Tool to remove the **56046** Lock Ring by turning it counterclockwise.
5. Pull the air motor assembly out of the housing. **Note:** Be aware that the **57264** Post Assembly, **56705** Post Cap, and **96252** Compression Spring will slip easily out of the motor shaft balancer.
6. Secure the counterweight of the motor shaft balancer in a vise equipped with aluminum or bronze jaws so that the motor assembly is pointing up.
7. Use the **50679**, 26mm Open End Wrench to remove the **56713** Lock Assembly by turning it clockwise. (Left Hand Threads)
8. Remove the **01020** O-Ring from the **56595** Cylinder and fasten a 2" bearing separator around the part of the cylinder that is closest to the **54629** Rear Bearing Plate.
9. Place the air motor with the bearing separator attached, onto the **96232**, #2 Arbor Press so that the counterweight is hanging down from the table of the arbor press.
10. Use a 5/16" dia. flat end drive punch as a press tool to push the motor shaft balancer out of the **01206** Bearing. Use the **96213** Bearing Removal Tool to push the **01206** Bearing out of the **54629** Rear Bearing Plate. **Note:** This bearing removal tool is not included in the **96283** Repair Kit.
11. Remove the cylinder, rotor, vanes and key.
12. Use a 2" bearing separator and arbor press to remove the **02695** Bearing. Remove **59057** "Top Hat" Seal and **59083** Felt from **54630** Front Bearing Plate.
13. Fasten the counterweight of the motor shaft balancer in a vise equipped with aluminum or bronze jaws so that the **57262** Balancer Shaft is pointing up.
14. Use a small flat blade screwdriver to remove the **95630** Snap Ring.
15. Use the **56056** Bearing Puller to remove the balancer bearing assembly.
16. Fasten the separator between the **57262** Balancer Shaft and the **95628** Bearing Shield.
17. Place the bearing separator on the table of the arbor press so that the hex end of the **57262** Balancer Shaft is pointing down. Use the 3/16" flat end drive punch as a press tool to push the balancer shaft out of the **56133** Bearing. Remove the **59084** V-Seal.

Motor Disassembly Complete.

Motor Assembly:

Important: Clean and inspect all motor parts for wear or defect.

1. Balancer Assembly:
 - a.) Install **59084** V-Seal onto the balancer shaft. Install with flexible lip of seal facing hex of balancer shaft. Be certain seal is pressed completely over shaft step. (See Drawing 1)
 - b.) Install **95360** Snap Ring between flange of **59084** V-Seal and hex of balancer shaft.
 - c.) Apply a small amount of the Loctite #271 (or equivalent) to the bearing surface of the **57069** Balancer Shaft.
 - d.) Use the large end of the **57091** Bearing Press Tool along with the **96232**, #2 Arbor Press to push the **56133** Bearing onto the balancer shaft until it fits against the shaft step. (Drawing 1)
2. Place the counterweight of the motor shaft balancer in a vise equipped with aluminum or bronze jaws so that the bearing pocket is pointing up.
3. Apply a small amount of the Loctite #271 (or equivalent) to the outside diameter of the **56133** Bearing. Slide the balancer shaft/bearing assembly all the way into the bearing pocket of the motor shaft balancer. Secure this assembly in the motor shaft balancer by squeezing the **95630** Snap Ring into the groove in the motor shaft balancer.
4. Install the **56046** Lock Ring onto the motor shaft balancer so that the "OFF" inscription is toward the counterweight of the shaft. Place the **59083** Felt into the **59057** "Top Hat" Seal. Install onto motor shaft balancer so they are centered as shown in Drawing 2.
5. Use the small end of the **57091** Bearing Press Tool and the arbor press to install the **02695** Bearing all the way onto the motor shaft balancer. (Drawing 2)
6. Install the **54630** Front Bearing Plate onto the **02695** Bearing and check it for smooth rotation. (Drawing 3)
7. Install the **54673** Key so that the 90° side of the key fits into the keyway of the shaft and the tapered side of the key fits into the rotor. Install the **54705** Rotor/Blade Set (5) onto the motor shaft balancer.
8. Apply the **95842** Dynabrade Air Lube (10W/NR or equivalent) to the blades.
9. Install the **56595** Cylinder over the rotor so that the short line-up pin fits into the front bearing plate.
10. Place the **54629** Rear Bearing Plate over the shaft so that the long line-up pin fits through the hole in the rear bearing plate. Use the small end of the **57091** Bearing Press Tool to install the **01206** Bearing onto the motor shaft balancer and into the **54629** Rear Bearing Plate. Use the press tool and the arbor press to install these so that there is a snug fit between the bearing plates and the cylinder. **Note:** Carefully press the **01206** Bearing onto the motor shaft balancer until it touches against the bearing seat on the inside of the bearing plate. (Drawing 4)
11. Secure the counterweight of the motor shaft balancer in a vise equipped with aluminum or bronze jaws so that the motor assembly is pointing up.
12. Apply a small amount of the Loctite #271 to the threads of the motor shaft balancer and use a 26mm Crow Foot Wrench to install the **56713** Lock Assembly by turning it counterclockwise. (Left Hand Thread) (Torque to 12 N·m/100 in. lbs.) Install **96252** Spring, **56705** Cap and **57264** Post Assembly.
13. Orient the flat side of the **56705** Post Cap toward the flared end of **57264** Post Assembly and install the post cap. Install the **96252** Compression Spring onto the post assembly and insert the post assembly, with the spring and post cap into the motor shaft balancer.
14. Apply a small amount of petroleum lubricant to the **01020** O-Ring and install the o-ring into the air inlet hole in the cylinder.
15. Install the motor assembly into the housing making sure to align the line-up pin with the line-up hole that is on the inside of the housing.
16. Use the **56058** Lock Ring Tool to tighten the lock ring and secure the motor in the housing. (Torque to 34 N·m/300 in. lbs.)
17. Install the appropriate shroud and weight-mated sanding pad.

Motor Assembly Complete.

Handle and Valve Disassembly:

1. Place the **57092** Repair Collar around the housing so that the handle is pointing up.
2. Use a Phillips screwdriver to remove the four screws that fasten the handle to the housing. Carefully pull the handle from the housing. This provides access to the tip valve components, also the handle; o-ring, gasket and vacuum plug.
3. Use a 1/8" dia. flat end drive punch to remove the **95627** Pin and the **56582** Throttle Safety Lever.

(continued text and diagrams on next page)

4. Pull the 56578 Speed Regulator and valve stem out of the housing.
Handle and Valve Disassembly Complete.

Handle and Valve Assembly:

1. Place the 57092 Repair Collar around the housing so that the handle mounting area is facing up.
2. Install the 01025 O-Rings (3) onto the 56578 Speed Regulator, apply a small amount of petroleum lubricant to the o-rings and insert the regulator assembly into the housing. **Note:** Be careful that the o-rings do not get caught and pulled out of the o-ring grooves.
3. Install the 98459 O-Ring onto the 56579 Valve Stem, apply a small amount of petroleum lubricant to the o-ring and insert the shortest portion (from the end to the o-ring) of the valve stem assembly into the speed regulator.
4. Install the 56582 Throttle Safety Lever onto the housing and secure it in place with the 95627 Pin.
5. Install the 56598 Seal into the air inlet passage of the housing.
6. Install the 56586 Vacuum Plug into the exhaust passage of the housing. (See Exploded View)
7. Use needle-nose pliers to grasp and install the 51944 Tip Valve so that it fits under the 56579 Valve Stem.
8. Install the large end of the 51943 Spring into the air inlet passage of the handle.
9. Install the 56469 Gasket onto the mounting surface of the handle.
10. Apply a small amount of petroleum lubricant to the 96459 O-Ring and install it onto the outside diameter of the air inlet passage at the location of the first shoulder.
11. Connect the handle to the housing and secure it in place with the four screws. **Note:** The two longer screws, Part Number 96454 (2) also secure the 56591 Grip to the housing.
12. Install the 56597 Muffler and secure it in place with the 56596 Muffler Clip. (See Exploded View)

Handle and Valve Assembly Complete. Tool Assembly Complete. Please allow 30 minutes for adhesives to cure before operating tool.

Important: Motor should now be tested for proper operation at 90 PSIG. If motor does not operate properly or operates at a higher RPM than marked on the tool, the tool should be serviced to correct the cause before use. Before operating, place 2-3 drops of Dynabrade Air Lube (P/N 95842) directly into air inlet with throttle lever depressed. Operate tool for 30 seconds to determine if tool is operating properly and to allow lubricating oils to properly penetrate motor.

Loctite® is a registered trademark of Loctite Corp.

Diagrams

Drawing 1

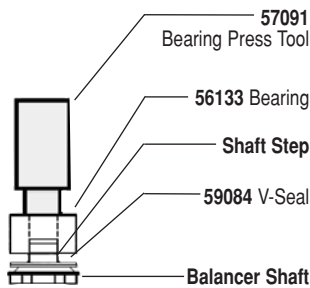

Drawing 2

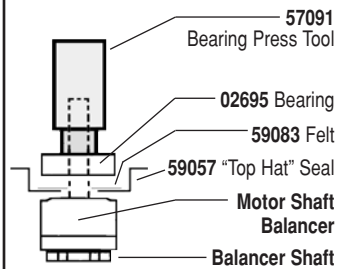

Important: Lock Ring must now be placed over sub-assembly. Not shown in drawings.

Drawing 3

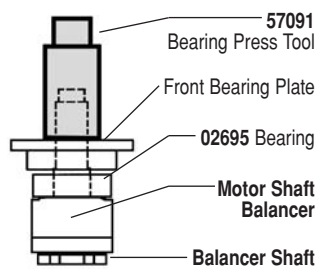

Drawing 4

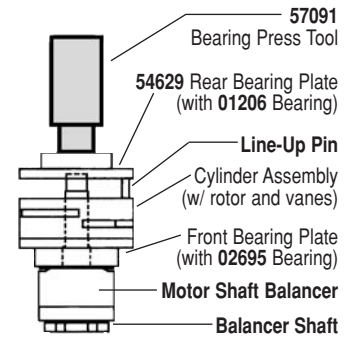

Optional Accessories



98220 Motor Tune-Up Kit

- Includes assorted parts to help maintain and repair motor.



96232 (#2) Arbor Press

- This arbor press is ideal for the disassembly and assembly of air motors.



96346 2" Bearing Separator

- Use the separator to remove gears and bearings.



Dynabrade Air Lube

- Formulated for pneumatic equipment.
 - Absorbs up to 10% of its weight in water.
 - Prevents rust and formation of sludge.
 - Keeps pneumatic tools operating longer with greater power and less down time.
- 95842: 1pt. (473 ml)
 95843: 1 gal. (3.8 L)



57260 Motor Repair Kit:

- Contains special tools for disassembly/assembly of machine.



For Use With:
5" Dynabuffer
5" & 6" Dynalocke™
5" & 6" Random Orbital Sanders

98220 Tune-Up Kit

Air Motor and Machine Parts

Parts included in tune-up kit are identified by part number. Not all parts are required for all tools.
 Please refer to appropriate parts page for additional identification and disassembly/assembly instructions.

Index Key		
No.	Part #	Description
1	95630	Snap Ring
2	56053	Bearing Seal
3	56133	Bearing
4	54673	Key
5	02695	Bearing
6	54674	Blade (5/Pkg.)
7	54671	Rotor
8	95911	O-Ring
9	01206	Bearing
10	95626	Retaining Ring
11	95627	Pin
12	98459	O-Ring
13	56579	Valve Stem
14	56598	Seal
15	51944	Tip Valve
16	51943	Spring
17	96459	O-Ring
18	56469	Exhaust Gasket
19	56597	Muffler

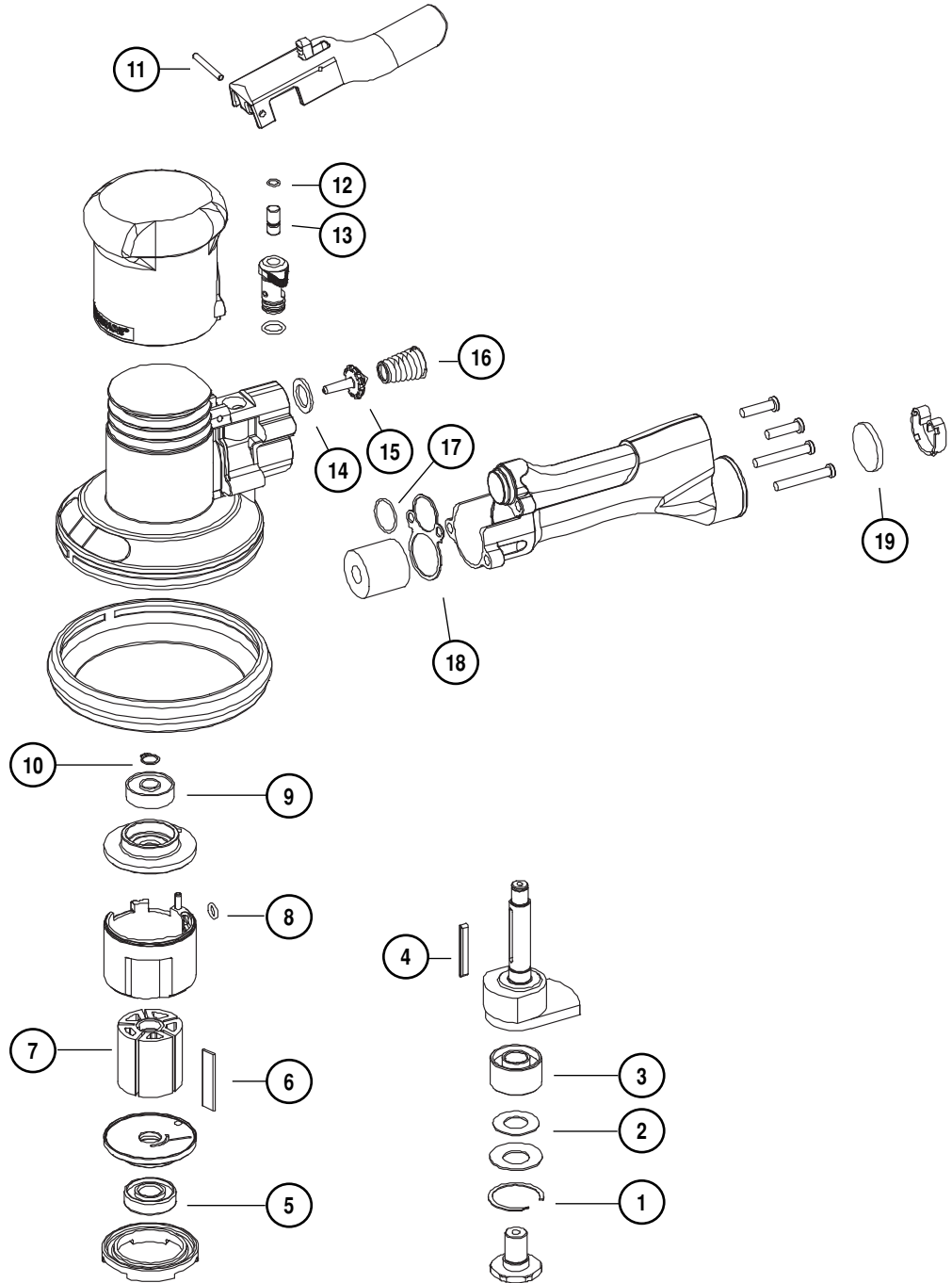

PREVENTATIVE MAINTENANCE SCHEDULE, DYNALOCKE SANDERS (T) IDENTIFIES 98220 TUNE-UP KIT PARTS

Index #	Part #	Description	# Req.	High Wear 100%	Medium Wear 70%	Low Wear 30%	Non-Wear 10%
1	SEE CHART	Sanding Pad	1	X			
2	57262	Balancer Shaft	1			X	
3	95630	Snap Ring	1		T		
4	59084	V-Ring Seal	1		T		
5	56133	Bearing	1	T			
6		Motor Shaft Balancer					
	57268	5 Inch Models	1				X
	57269	6 Inch Models	1				X
7	54673	Key	1		T		
8	56046	Lock Ring	1				X
9	59057	Front Bearing Seal	1			T	
10	59083	Felt Washer	1	T			
11	02695	Bearing	1		T		
12	54630	Front Bearing Plate	1				X
13	54705	Rotor/Vane Set (5/pkg)	1	T			
14	56595	Cylinder (includes 95865 Pin)	1			X	
15	95865	Pin	1				X
16	95911	O-Ring	1		T		
17	54629	Rear Bearing Plate	1				X
18	01206	Bearing	1		T		
19	56713	Lock Assembly	1				X
20	96252	Spring	1			X	
21	56705	Post Cap	1			X	
22	57264	Post Assembly	1			X	
23	56712	Switch Bottom	1			X	
24	96478	O-Ring	1			X	
25	57369	Shroud	1				X
26	64452	Housing Assembly (includes 56591 Grip & Label)	1				X
27	56591	Grip	1			X	
28	56711	Switch Top	1			X	
29	96489	Screw	1			X	
30	95627	Pin	1		T		
31	56582	Throttle Safety Lever	1			X	
32	98459	O-Ring	1			T	
33	56579	Valve Stem	1			T	
34	56578	Speed Regulator	1			X	
35	01025	O-Ring	3			X	
36	56598	Seal	1			T	
37	51944	Tip Valve	1			T	
38	51943	Spring	1			T	
39	56586	Vacuum Plug	1			X	
40	96459	O-Ring	1			T	
41	56469	Exhaust Gasket	1			T	
42	96454	Screw	2				X
43	96469	Screw	2				X
44	56468	Handle Assembly (includes 51938 Screen)	1				X
45	56597	Muffler	1		T		
46	56596	Muffler Clip	1			X	

Dynalocke™ Dual Action Sander

12,000 RPM, 3/16" Orbit Air Motor and Machine Parts

Models:

58430 - 5" Pad, Non-Vac
58431 - 5" Pad, Vac-Ready

58435 - 6" Pad, Non-Vac
58436 - 6" Pad, Vac-Ready

! WARNING

Always operate, inspect and maintain this tool in accordance with the Safety Code for portable air tools (ANSI B186.1) and any other applicable safety codes and regulations. Please refer to Dynabrade's Warning/Safety Operating Instructions for more complete safety information.

Index Key

No.	Part #	Description
1		Sanding Pad: See Chart
2	57262	Balancer Shaft
3	95630	Snap Ring
4	59084	V-Seal
5	56133	Bearing
6		Motor Shaft Balancer:
	57268	5"
	57269	6"
7	54673	Key
8	56046	Lock Ring
9	59057	"Top Hat" Seal
10	59083	Felt
11	02695	Bearing
12	54630	Front Bearing Plate
13	54705	Rotor/Blade Set (5/pkg.)
14	56595	Cylinder (Includes: 95865 Pin)
15	01020	O-Ring
16	54629	Rear Bearing Plate
17	01206	Bearing
18	56713	Lock Assembly
19	96252	Compression Spring
20	56705	Post Cap
21	57264	Post Assembly
22	56712	Switch Bottom
23	96478	O-Ring
24	57369	Shroud
25		Housing: See Chart (Includes: 56591 Housing Grip and Labels)
26	56711	Switch Top
27	96489	Screw
28	95627	Pin
29	56582	Safety Throttle Lever
30	98459	O-Ring
31	56579	Valve Stem
32	56578	Speed Regulator
33	01025	O-Ring (3)
34	56598	Seal
35	51944	Tip Valve
36	51943	Spring
37	56586*	Vacuum Plug
38	96459	O-Ring
39	56469	Exhaust Gasket
40	56468	Handle Assembly (Includes: 51938 Inlet Screen)
41	96469	Screw (2)
42	96454	Screw (2)
43	56597*	Muffler
44	56596*	Muffler Cap

*Parts included with Non-Vacuum Models Only.

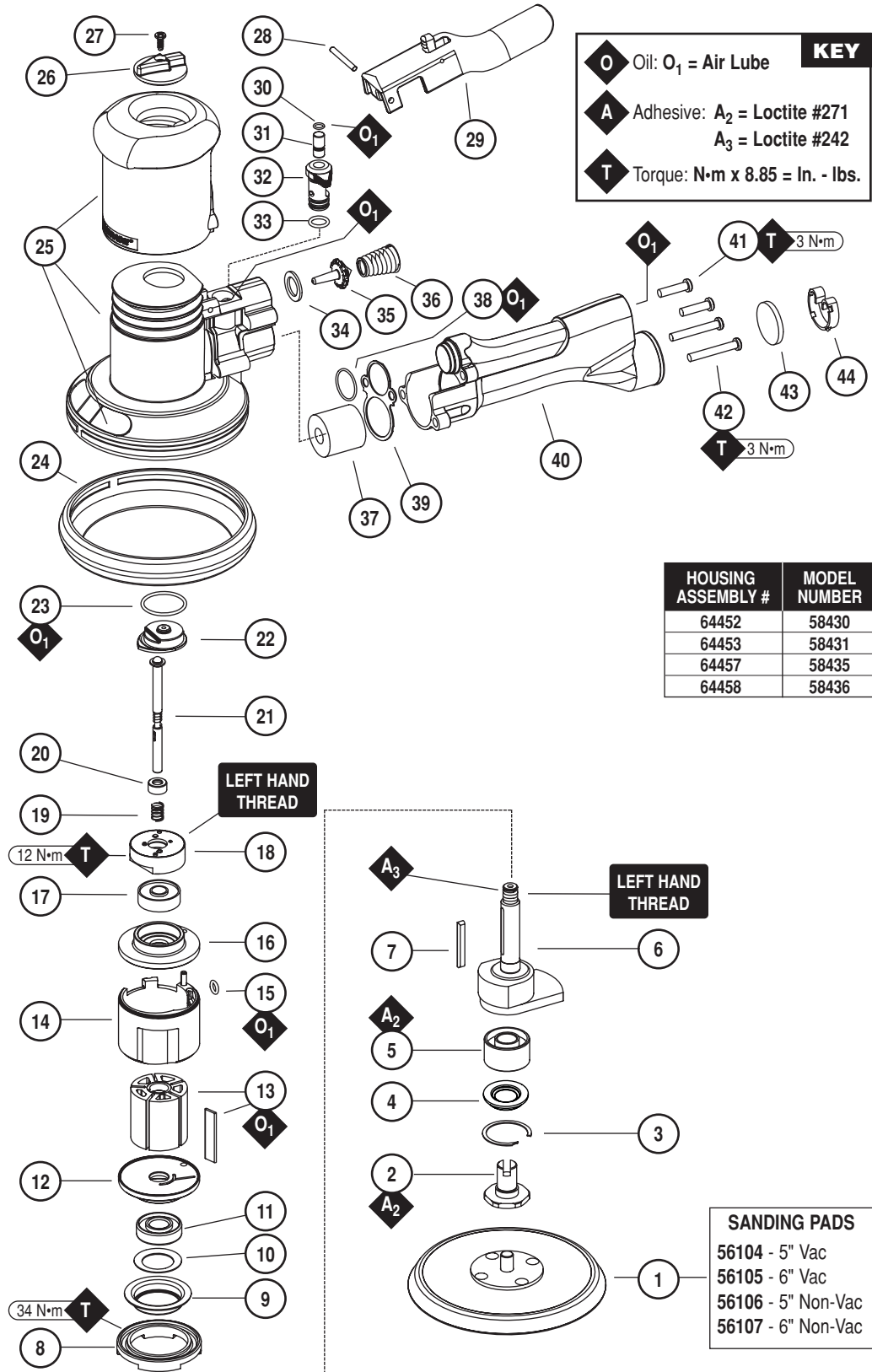

KEY

- O** Oil: O₁ = Air Lube
- A** Adhesive: A₂ = Loctite #271
A₃ = Loctite #242
- T** Torque: N•m x 8.85 = In. - lbs.

HOUSING ASSEMBLY #	MODEL NUMBER
64452	58430
64453	58431
64457	58435
64458	58436

SANDING PADS

56104	- 5" Vac
56105	- 6" Vac
56106	- 5" Non-Vac
56107	- 6" Non-Vac

Important Operating, Maintenance and Safety Instructions

Carefully read all instructions before operating or servicing any Dynabrade® Abrasive Power Tool.

Warning: Hand, wrist and arm injury may result from repetitive work motion and overexposure to vibration.

Important: All Dynabrade Rotary Vane air tools must be used with a Filter-Regulator-Lubricator to maintain all warranties.

Operating Instructions:

Warning: Eye, face, respiratory, sound and body protection must be worn while operating power tools. Failure to do so may result in serious injury or death. Follow safety procedures posted in workplace.

1. With power source disconnected from tool, securely fasten abrasive/accessory on tool.
2. Install air fitting into inlet bushing of tool. **Important:** Secure inlet bushing of tool with a wrench before attempting to install the air fitting to avoid damaging valve body housing.
3. Connect power source to tool. Be careful not to depress throttle lever in the process.
4. Air tools are not intended for use in explosive atmospheres and are not insulated for contact with electrical power sources. Sanding/Grinding certain materials can create explosive dust. It is the employers responsibility to notify the user of acceptable dust levels. Sanding/Grinding can cause sparks which can cause fires or explosions. It is the users responsibility to make sure the work area is free of flammable materials.

Maintenance Instructions:

1. Check tool speed regularly with a tachometer. If tool is operating at a higher speed than the RPM marked on the tool, the tool should be serviced to correct the cause before use.
2. Some silencers on air tools may clog with use. Clean and replace as required.
3. All Dynabrade Rotary Vane air motors should be lubricated. Dynabrade recommends one drop of air lube per minute for each 20 SCFM (example: if the tool specifications state 40 SCFM, set the drip rate of your filter-lubricator at 2 drops per minute). Dynabrade Air Lube (P/N **95842**: 1 pt. 473 ml.) is recommended.
4. It is strongly recommended that all Dynabrade rotary vane air tools be used with a Filter-Regulator-Lubricator to minimize the possibility of misuse due to unclear air, wet air or insufficient lubrication. Dynabrade recommends the following: **11405** Air Line Filter-Regulator-Lubricator — Provides accurate air pressure regulation, two-stage filtration of water contaminants and micro-mist lubrication of pneumatic components. Operates 40 SCFM @ 100 PSIG has 3/8" NPT female ports.
5. Use only genuine Dynabrade replacement parts. To reorder replacement parts, specify the **Model #**, **Serial #**, and **RPM** of your machine.
6. A Motor Tune-Up Kit (P/N **98220**) is available which includes assorted parts to help maintain motor in peak operating condition. Please refer to Dynabrade's Preventative Maintenance Schedule for a guide to expectant life of component parts.
7. Mineral spirits are recommended when cleaning the tool and parts. Do not clean tool or parts with any solvents or oils containing acids, esters, ketones, chlorinated hydrocarbons or nitro carbons.
8. DO NOT clean or maintain air tools with chemicals that have a low flash point (example: WD-40®).

Safety Instructions:

Products offered by Dynabrade should not be converted or otherwise altered from original design without expressed written consent from Dynabrade, Inc.



- **Important:** User of tool is responsible for following accepted safety codes such as those published by the American National Standards Institute (ANSI).
- Always disconnect power supply before changing abrasive/accessory or making machine adjustments.
- Inspect abrasives/accessories for damage or defects prior to installation on tools.
- Please refer to Dynabrade's Warning/Safety Operating Instructions Tag (Reorder No. **95903**) for more complete safety information.

Notice

All Dynabrade motors use the highest quality parts and metals available and are machined to exacting tolerances. The failure of quality pneumatic motors can most often be traced to an unclean air supply or the lack of lubrication. Air pressure easily forces dirt or water contained in the air supply into motor bearings causing early failure. It often scores the cylinder walls and the rotor blades resulting in limited efficiency and power. Our warranty obligation is contingent upon proper use of our tools and cannot apply to equipment which has been subjected to misuse such as unclean air, wet air or a lack of lubrication during the use of this tool.

Full One Year Warranty

Following the reasonable assumption that any inherent defect which might prevail in a product will become apparent to the user within one year from the date of purchase, all equipment of our manufacture is warranted against defects in workmanship and materials under normal use and service. We shall repair or replace at our factory, any equipment or part thereof which shall, within one year after delivery to the original purchaser, indicate upon our examination to have been defective. Our obligation is contingent upon proper use of Dynabrade tools in accordance with factory recommendations, instructions and safety practices. It shall not apply to equipment which has been subject to misuse, negligence, accident or tampering in any way so as to affect its normal performance. Normally wearable parts such as bearings, contact wheels, rotor blades, etc., are not covered under this warranty.

Model Number	Motor hp (W)	Motor RPM	Pad Dia. Inch (mm)	Sound Level	Maximum Air Flow SCFM (LPM)	Hose I.D. Size Inch (mm)	Air Inlet Thread	Tool Thread	Weight Pound (kg)	Length Inch (mm)	Height Inch (mm)
58430	.45 (336)	12,000	5 (127)	82 dB(A)	23 (651)	1/4 (6)	1/4" NPT	5/16"-24 Female	2.7 (1.2)	11-1/16 (280)	5-1/8 (131)
58431	.45 (336)	12,000	5 (127)	82 dB(A)	23 (651)	1/4 (6)	1/4" NPT	5/16"-24 Female	2.6 (1.2)	11-1/16 (280)	5-1/8 (131)
58435	.45 (336)	12,000	6 (152)	82 dB(A)	23 (651)	1/4 (6)	1/4" NPT	5/16"-24 Female	2.8 (1.3)	11-1/2 (293)	5-1/8 (131)
58436	.45 (336)	12,000	6 (152)	85 dB(A)	23 (651)	1/4 (6)	1/4" NPT	5/16"-24 Female	2.7 (1.2)	11-1/2 (293)	5-1/8 (131)

Additional Specifications: Air Pressure 90 PSIG (6.2 Bar)

Disassembly/Assembly Instructions

Important: The manufacturer's warranty is void if the tool is disassembled before the warranty expires. Use these instructions in conjunction with the Part Number 57260 Tool Repair Kit. This kit includes special tooling for the proper disassembly/assembly of the Two-Hand Dynalocke Sander. This Tooling will be referred to in these instructions. An air motor Tune-Up Kit, Part Number 98220 is also available. It contains the high and medium wear components that most commonly need replacement.

Motor Disassembly:

1. Disconnect the sander from the air supply.
2. Use the **57092** Repair Collar to hold the sander in a vise. Position the sander so that the sanding pad is facing up. **Note:** Do not over tighten the collar and sander in the vise. Only hold the sander snugly, so that the motor lock ring can be removed easily.
3. Use the **50679** 26mm Open End Wrench to remove the sanding pad from the sander by holding the **57262** Balancer Shaft stationary and turning the pad counterclockwise.
4. Use the **56058** Lock Ring Tool to remove the **56046** Lock Ring by turning it counterclockwise.
5. Pull the air motor assembly out of the housing. **Note:** Be aware that the **57264** Post Assembly, **56705** Post Cap, and **96252** Compression Spring will slip easily out of the motor shaft balancer.
6. Secure the counterweight of the motor shaft balancer in a vise equipped with aluminum or bronze jaws so that the motor assembly is pointing up.
7. Use the **50679**, 26mm Open End Wrench to remove the **56713** Lock Assembly by turning it clockwise. (Left Hand Threads)
8. Remove the **01020** O-Ring from the **56595** Cylinder and fasten a 2" bearing separator around the part of the cylinder that is closest to the **54629** Rear Bearing Plate.
9. Place the air motor with the bearing separator attached, onto the **96232**, #2 Arbor Press so that the counterweight is hanging down from the table of the arbor press.
10. Use a 5/16" dia. flat end drive punch as a press tool to push the motor shaft balancer out of the **01206** Bearing. Use the **96213** Bearing Removal Tool to push the **01206** Bearing out of the **54629** Rear Bearing Plate. **Note:** This bearing removal tool is not included in the **96283** Repair Kit.
11. Remove the cylinder, rotor, vanes and key.
12. Use a 2" bearing separator and arbor press to remove the **02695** Bearing. Remove **59057** "Top Hat" Seal and **59083** Felt from **54630** Front Bearing Plate.
13. Fasten the counterweight of the motor shaft balancer in a vise equipped with aluminum or bronze jaws so that the **57262** Balancer Shaft is pointing up.
14. Use a small flat blade screwdriver to remove the **95630** Snap Ring.
15. Use the **56056** Bearing Puller to remove the balancer bearing assembly.
16. Fasten the separator between the **57262** Balancer Shaft and the **95628** Bearing Shield.
17. Place the bearing separator on the table of the arbor press so that the hex end of the **57262** Balancer Shaft is pointing down. Use the 3/16" flat end drive punch as a press tool to push the balancer shaft out of the **56133** Bearing. Remove the **59084** V-Seal.

Motor Disassembly Complete.

Motor Assembly:

Important: Clean and inspect all motor parts for wear or defect.

1. Balancer Assembly:
 - a.) Install **59084** V-Seal onto the balancer shaft. Install with flexible lip of seal facing hex of balancer shaft. Be certain seal is pressed completely over shaft step. (See Drawing 1)
 - b.) Install **95360** Snap Ring between flange of **59084** V-Seal and hex of balancer shaft.
 - c.) Apply a small amount of the Loctite #271 (or equivalent) to the bearing surface of the **57069** Balancer Shaft.
 - d.) Use the large end of the **57091** Bearing Press Tool along with the **96232**, #2 Arbor Press to push the **56133** Bearing onto the balancer shaft until it fits against the shaft step. (Drawing 1)
2. Place the counterweight of the motor shaft balancer in a vise equipped with aluminum or bronze jaws so that the bearing pocket is pointing up.
3. Apply a small amount of the Loctite #271 (or equivalent) to the outside diameter of the **56133** Bearing. Slide the balancer shaft/bearing assembly all the way into the bearing pocket of the motor shaft balancer. Secure this assembly in the motor shaft balancer by squeezing the **95630** Snap Ring into the groove in the motor shaft balancer.
4. Install the **56046** Lock Ring onto the motor shaft balancer so that the "OFF" inscription is toward the counterweight of the shaft. Place the **59083** Felt into the **59057** "Top Hat" Seal. Install onto motor shaft balancer so they are centered as shown in Drawing 2.
5. Use the small end of the **57091** Bearing Press Tool and the arbor press to install the **02695** Bearing all the way onto the motor shaft balancer. (Drawing 2)
6. Install the **54630** Front Bearing Plate onto the **02695** Bearing and check it for smooth rotation. (Drawing 3)
7. Install the **54673** Key so that the 90° side of the key fits into the keyway of the shaft and the tapered side of the key fits into the rotor. Install the **54705** Rotor/Blade Set (5) onto the motor shaft balancer.
8. Apply the **95842** Dynabrade Air Lube (10W/NR or equivalent) to the blades.
9. Install the **56595** Cylinder over the rotor so that the short line-up pin fits into the front bearing plate.
10. Place the **54629** Rear Bearing Plate over the shaft so that the long line-up pin fits through the hole in the rear bearing plate. Use the small end of the **57091** Bearing Press Tool to install the **01206** Bearing onto the motor shaft balancer and into the **54629** Rear Bearing Plate. Use the press tool and the arbor press to install these so that there is a snug fit between the bearing plates and the cylinder. **Note:** Carefully press the **01206** Bearing onto the motor shaft balancer until it touches against the bearing seat on the inside of the bearing plate. (Drawing 4)
11. Secure the counterweight of the motor shaft balancer in a vise equipped with aluminum or bronze jaws so that the motor assembly is pointing up.
12. Apply a small amount of the Loctite #271 to the threads of the motor shaft balancer and use a 26mm Crow Foot Wrench to install the **56713** Lock Assembly by turning it counterclockwise. (Left Hand Thread) (Torque to 12 N·m/100 in. lbs.) Install **96252** Spring, **56705** Cap and **57264** Post Assembly.
13. Orient the flat side of the **56705** Post Cap toward the flared end of **57264** Post Assembly and install the post cap. Install the **96252** Compression Spring onto the post assembly and insert the post assembly, with the spring and post cap into the motor shaft balancer.
14. Apply a small amount of petroleum lubricant to the **01020** O-Ring and install the o-ring into the air inlet hole in the cylinder.
15. Install the motor assembly into the housing making sure to align the line-up pin with the line-up hole that is on the inside of the housing.
16. Use the **56058** Lock Ring Tool to tighten the lock ring and secure the motor in the housing. (Torque to 34 N·m/300 in. lbs.)
17. Install the appropriate shroud and weight-mated sanding pad.

Motor Assembly Complete.

Handle and Valve Disassembly:

1. Place the **57092** Repair Collar around the housing so that the handle is pointing up.
2. Use a Phillips screwdriver to remove the four screws that fasten the handle to the housing. Carefully pull the handle from the housing. This provides access to the tip valve components, also the handle; o-ring, gasket and vacuum plug.
3. Use a 1/8" dia. flat end drive punch to remove the **95627** Pin and the **56582** Throttle Safety Lever.

(continued text and diagrams on next page)

4. Pull the 56578 Speed Regulator and valve stem out of the housing.
Handle and Valve Disassembly Complete.

Handle and Valve Assembly:

1. Place the 57092 Repair Collar around the housing so that the handle mounting area is facing up.
2. Install the 01025 O-Rings (3) onto the 56578 Speed Regulator, apply a small amount of petroleum lubricant to the o-rings and insert the regulator assembly into the housing. **Note:** Be careful that the o-rings do not get caught and pulled out of the o-ring grooves.
3. Install the 98459 O-Ring onto the 56579 Valve Stem, apply a small amount of petroleum lubricant to the o-ring and insert the shortest portion (from the end to the o-ring) of the valve stem assembly into the speed regulator.
4. Install the 56582 Throttle Safety Lever onto the housing and secure it in place with the 95627 Pin.
5. Install the 56598 Seal into the air inlet passage of the housing.
6. Install the 56586 Vacuum Plug into the exhaust passage of the housing. (See Exploded View)
7. Use needle-nose pliers to grasp and install the 51944 Tip Valve so that it fits under the 56579 Valve Stem.
8. Install the large end of the 51943 Spring into the air inlet passage of the handle.
9. Install the 56469 Gasket onto the mounting surface of the handle.
10. Apply a small amount of petroleum lubricant to the 96459 O-Ring and install it onto the outside diameter of the air inlet passage at the location of the first shoulder.
11. Connect the handle to the housing and secure it in place with the four screws. **Note:** The two longer screws, Part Number 96454 (2) also secure the 56591 Grip to the housing.
12. Install the 56597 Muffler and secure it in place with the 56596 Muffler Clip. (See Exploded View)

Handle and Valve Assembly Complete. Tool Assembly Complete. Please allow 30 minutes for adhesives to cure before operating tool.

Important: Motor should now be tested for proper operation at 90 PSIG. If motor does not operate properly or operates at a higher RPM than marked on the tool, the tool should be serviced to correct the cause before use. Before operating, place 2-3 drops of Dynabrade Air Lube (P/N 95842) directly into air inlet with throttle lever depressed. Operate tool for 30 seconds to determine if tool is operating properly and to allow lubricating oils to properly penetrate motor.

Loctite® is a registered trademark of Loctite Corp.

Diagrams

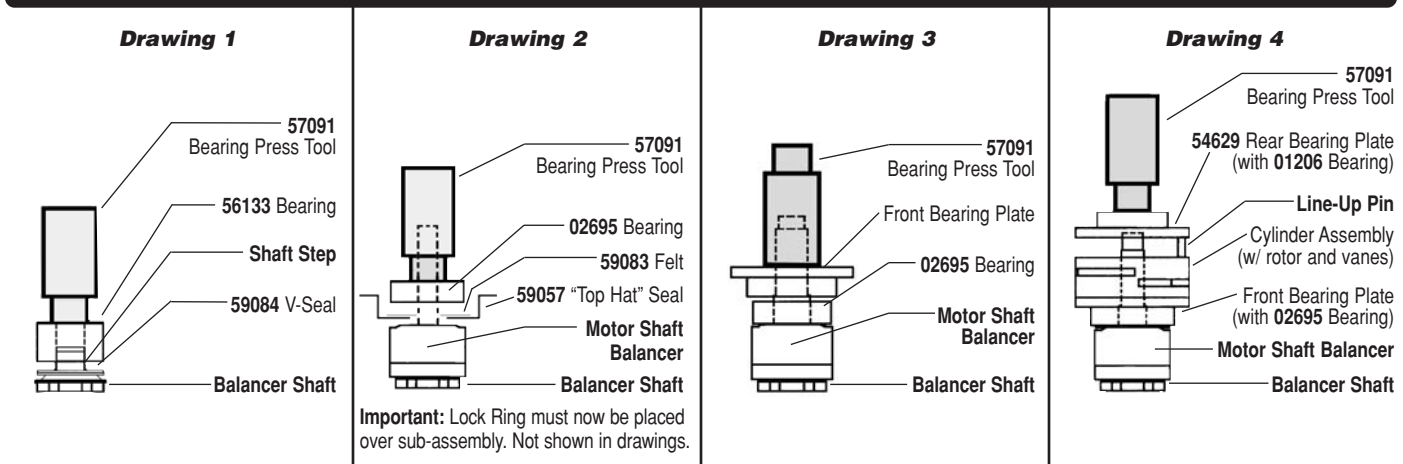

Optional Accessories



98220 Motor Tune-Up Kit

- Includes assorted parts to help maintain and repair motor.



Dynabrade Air Lube

- Formulated for pneumatic equipment.
 - Absorbs up to 10% of its weight in water.
 - Prevents rust and formation of sludge.
 - Keeps pneumatic tools operating longer with greater power and less down time.
- 95842: 1pt. (473 ml)
 95843: 1 gal. (3.8 L)



96232 (#2) Arbor Press

- This arbor press is ideal for the disassembly and assembly of air motors.



57260 Motor Repair Kit:

- Contains special tools for disassembly/assembly of machine.



96346 2" Bearing Separator

- Use the separator to remove gears and bearings.



Dynalocke™ Dual Action Sander

12,000 RPM, 3/16" Orbit Air Motor and Machine Parts

Models:

58430 - 5" Pad, Non-Vac
58431 - 5" Pad, Vac-Ready

58435 - 6" Pad, Non-Vac
58436 - 6" Pad, Vac-Ready

! WARNING

Always operate, inspect and maintain this tool in accordance with the Safety Code for portable air tools (ANSI B186.1) and any other applicable safety codes and regulations. Please refer to Dynabrade's Warning/Safety Operating Instructions for more complete safety information.

Index Key

No.	Part #	Description
1		Sanding Pad: See Chart
2	57262	Balancer Shaft
3	95630	Snap Ring
4	95628	Bearing Shield
5	56053	Bearing Seal
6	56133	Bearing
7		Motor Shaft Balancer:
	57268	5"
	57269	6"
8	54673	Key
9	56046	Lock Ring
10	02695	Bearing
11	54630	Front Bearing Plate
12	54705	Rotor/Blade Set (5/pkg.)
13	56595	Cylinder (Includes: 95865 Pin)
14	01020	O-Ring
15	54629	Rear Bearing Plate
16	01206	Bearing
17	56713	Lock Assembly
18	96252	Compression Spring
19	56705	Post Cap
20	57264	Post Assembly
21	56712	Switch Bottom
22	96478	O-Ring
23	57369	Shroud
24		Housing: See Chart (Includes: 56591 Housing Grip and Labels)
25	56711	Switch Top
26	96489	Screw
27	95627	Pin
28	56582	Safety Throttle Lever
29	98459	Valve Stem
30	56579	Valve Stem
31	56578	Speed Regulator
32	01025	O-Ring (3)
33	56598	Seal
34	51944	Tip Valve
35	51943	Spring
36	56586*	Vacuum Plug
37	96459	O-Ring
38	56469	Exhaust Gasket
39	56468	Handle Assembly (Includes: 51938 Inlet Screen)
40	96469	Screw (2)
41	96454	Screw (2)
42	56597*	Muffler
43	56596*	Muffler Cap

*Parts included with Non-Vacuum Models Only.

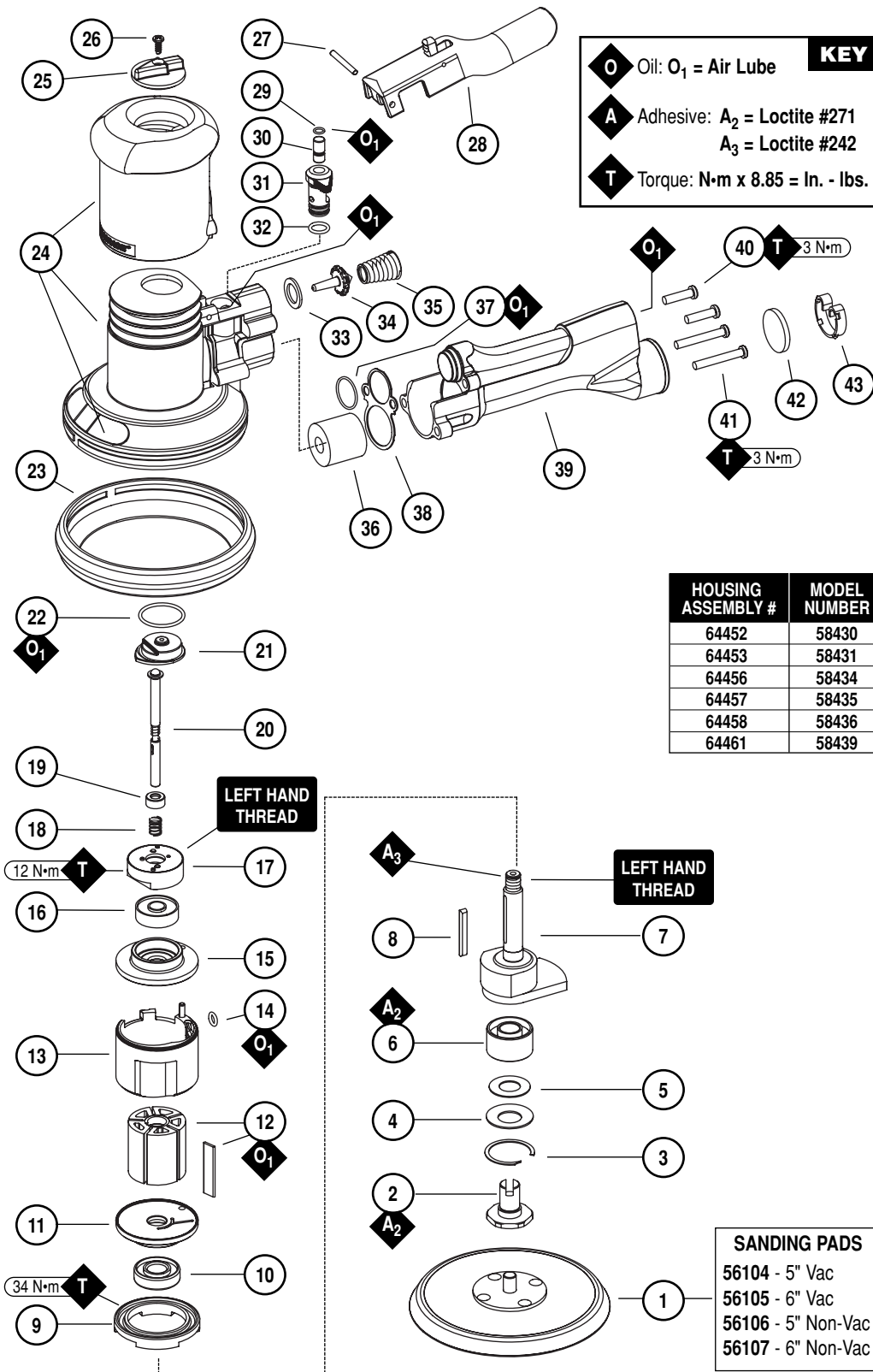

KEY	
O	Oil: O ₁ = Air Lube
A	Adhesive: A ₂ = Loctite #271 A ₃ = Loctite #242
T	Torque: N•m x 8.85 = In. - lbs.

HOUSING ASSEMBLY #	MODEL NUMBER
64452	58430
64453	58431
64456	58434
64457	58435
64458	58436
64461	58439

SANDING PADS	
56104	5" Vac
56105	6" Vac
56106	5" Non-Vac
56107	6" Non-Vac

Important Operating, Maintenance and Safety Instructions

Carefully read all instructions before operating or servicing any Dynabrade® Abrasive Power Tool.

Warning: Hand, wrist and arm injury may result from repetitive work motion and overexposure to vibration.

Important: All Dynabrade Rotary Vane air tools must be used with a Filter-Regulator-Lubricator to maintain all warranties.

Operating Instructions:

Warning: Eye, face, respiratory, sound and body protection must be worn while operating power tools. Failure to do so may result in serious injury or death. Follow safety procedures posted in workplace.

1. With power source disconnected from tool, securely fasten abrasive/accessory on tool.
2. Install air fitting into inlet bushing of tool. **Important:** Secure inlet bushing of tool with a wrench before attempting to install the air fitting to avoid damaging valve body housing.
3. Connect power source to tool. Be careful not to depress throttle lever in the process.
4. Air tools are not intended for use in explosive atmospheres and are not insulated for contact with electrical power sources. Sanding/Grinding certain materials can create explosive dust. It is the employers responsibility to notify the user of acceptable dust levels. Sanding/Grinding can cause sparks which can cause fires or explosions. It is the users responsibility to make sure the work area is free of flammable materials.

Maintenance Instructions:

1. Check tool speed regularly with a tachometer. If tool is operating at a higher speed than the RPM marked on the tool, the tool should be serviced to correct the cause before use.
2. Some silencers on air tools may clog with use. Clean and replace as required.
3. All Dynabrade Rotary Vane air motors should be lubricated. Dynabrade recommends one drop of air lube per minute for each 20 SCFM (example: if the tool specifications state 40 SCFM, set the drip rate of your filter-lubricator at 2 drops per minute). Dynabrade Air Lube (P/N **95842**: 1 pt. 473 ml.) is recommended.
4. It is strongly recommended that all Dynabrade rotary vane air tools be used with a Filter-Regulator-Lubricator to minimize the possibility of misuse due to unclear air, wet air or insufficient lubrication. Dynabrade recommends the following: **11405** Air Line Filter-Regulator-Lubricator — Provides accurate air pressure regulation, two-stage filtration of water contaminants and micro-mist lubrication of pneumatic components. Operates 40 SCFM @ 100 PSIG has 3/8" NPT female ports.
5. Use only genuine Dynabrade replacement parts. To reorder replacement parts, specify the **Model #**, **Serial #**, and **RPM** of your machine.
6. A Motor Tune-Up Kit (P/N **98220**) is available which includes assorted parts to help maintain motor in peak operating condition. Please refer to Dynabrade's Preventative Maintenance Schedule for a guide to expectant life of component parts.
7. Mineral spirits are recommended when cleaning the tool and parts. Do not clean tool or parts with any solvents or oils containing acids, esters, keytones, chlorinated hydrocarbons or nitro carbons.
8. DO NOT clean or maintain air tools with chemicals that have a low flash point (example: WD-40®).

Safety Instructions:

Products offered by Dynabrade should not be converted or otherwise altered from original design without expressed written consent from Dynabrade, Inc.



- **Important:** User of tool is responsible for following accepted safety codes such as those published by the American National Standards Institute (ANSI).
- Always disconnect power supply before changing abrasive/accessory or making machine adjustments.
- Inspect abrasives/accessories for damage or defects prior to installation on tools.
- Please refer to Dynabrade's Warning/Safety Operating Instructions Tag (Reorder No. **95903**) for more complete safety information.

Notice

All Dynabrade motors use the highest quality parts and metals available and are machined to exacting tolerances. The failure of quality pneumatic motors can most often be traced to an unclean air supply or the lack of lubrication. Air pressure easily forces dirt or water contained in the air supply into motor bearings causing early failure. It often scores the cylinder walls and the rotor blades resulting in limited efficiency and power. Our warranty obligation is contingent upon proper use of our tools and cannot apply to equipment which has been subjected to misuse such as unclean air, wet air or a lack of lubrication during the use of this tool.

Full One Year Warranty

Following the reasonable assumption that any inherent defect which might prevail in a product will become apparent to the user within one year from the date of purchase, all equipment of our manufacture is warranted against defects in workmanship and materials under normal use and service. We shall repair or replace at our factory, any equipment or part thereof which shall, within one year after delivery to the original purchaser, indicate upon our examination to have been defective. Our obligation is contingent upon proper use of Dynabrade tools in accordance with factory recommendations, instructions and safety practices. It shall not apply to equipment which has been subject to misuse, negligence, accident or tampering in any way so as to affect its normal performance. Normally wearable parts such as bearings, contact wheels, rotor blades, etc., are not covered under this warranty.

Model Number	Motor hp (W)	Motor RPM	Pad Dia. Inch (mm)	Sound Level	Maximum Air Flow CFM/SCFM (LPM)	Hose I.D. Size Inch or (mm)	Air Inlet Thread	Tool Thread	Weight Pound (kg)	Length Inch (mm)	Height Inch (mm)
58430	.45 (336)	12,000	5 (127)	82 dB(A)	3/23 (651)	1/4 or (8)	1/4" NPT	5/16"-24 Female	2.7 (1.2)	11-1/16 (280)	5-1/8 (131)
58431	.45 (336)	12,000	5 (127)	82 dB(A)	3/23 (651)	1/4 or (8)	1/4" NPT	5/16"-24 Female	2.6 (1.2)	11-1/16 (280)	5-1/8 (131)
58435	.45 (336)	12,000	6 (152)	82 dB(A)	3/23 (651)	1/4 or (8)	1/4" NPT	5/16"-24 Female	2.8 (1.3)	11-1/2 (293)	5-1/8 (131)
58436	.45 (336)	12,000	6 (152)	85 dB(A)	3/23 (651)	1/4 or (8)	1/4" NPT	5/16"-24 Female	2.7 (1.2)	11-1/2 (293)	5-1/8 (131)

Additional Specifications: Air Pressure 90 PSIG (6.2 Bar)

Disassembly/Assembly Instructions

Important: The manufacturer's warranty is void if the tool is disassembled before the warranty expires. Use these instructions in conjunction with the Part Number 57260 Tool Repair Kit. This kit includes special tooling for the proper disassembly/assembly of the Two-Hand Dynalocke Sander. This Tooling will be referred to in these instructions. An air motor Tune-Up Kit, Part Number 99220 is also available. It contains the high and medium wear components that most commonly need replacement.

Motor Disassembly:

1. Disconnect the sander from the air supply.
2. Use the **57092** Repair Collar to hold the sander in a vise. Position the sander so that the sanding pad is facing up. **Note:** Do not over tighten the collar and sander in the vise. Only hold the sander snugly, so that the motor lock ring can be removed easily.
3. Use the **50679** 26mm Open End Wrench to remove the sanding pad from the sander by holding the **57262** Balancer Shaft stationary and turning the pad counterclockwise.
4. Use the **56058** Lock Ring Tool to remove the **56046** Lock Ring by turning it counterclockwise.
5. Pull the air motor assembly out of the housing. **Note:** Be aware that the **57264** Post Assembly, **56705** Post Cap, and **96252** Compression Spring will slip easily out of the motor shaft balancer.
6. Secure the counterweight of the motor shaft balancer in a vise equipped with aluminum or bronze jaws so that the motor assembly is pointing up.
7. Use the **50679**, 26mm Open End Wrench to remove the **56713** Lock Assembly by turning it clockwise. (Left Hand Threads)
8. Remove the **01020** O-Ring from the **56595** Cylinder and fasten a 2" bearing separator around the part of the cylinder that is closest to the **54629** Rear Bearing Plate.
9. Place the air motor with the bearing separator attached, onto the **96232**, #2 Arbor Press so that the counterweight is hanging down from the table of the arbor press.
10. Use a 5/16" dia. flat end drive punch as a press tool to push the motor shaft balancer out of the **01206** Bearing. Use the **96213** Bearing Removal Tool to push the **01206** Bearing out of the **54629** Rear Bearing Plate. **Note:** This bearing removal tool is not included in the **96283** Repair Kit.
11. Remove the cylinder, rotor, vanes, key and the **54630** Front Bearing Plate.
12. Use a 2" bearing separator and arbor press to remove the **02695** Bearing.
13. Fasten the counterweight of the motor shaft balancer in a vise equipped with aluminum or bronze jaws so that the **57262** Balancer Shaft is pointing up.
14. Use a small flat blade screwdriver to remove the **95630** Snap Ring.
15. Use the **56056** Bearing Puller to remove the balancer bearing assembly.
16. Fasten the separator between the **57262** Balancer Shaft and the **95628** Bearing Shield.
17. Place the bearing separator on the table of the arbor press so that the hex end of the **57262** Balancer Shaft is pointing down. Use the 3/16" flat end drive punch as a press tool to push the balancer shaft out of the **56133** Bearing. Remove the **56053** Bearing Seal and the **95628** Bearing Shield.

Motor Disassembly Complete.

Motor Assembly:

Important: Clean and inspect all motor parts for wear or defect.

1. Balancer Assembly:
 - a. Install the **95630** Snap Ring onto the **57262** Balancer Shaft.
 - b. Install the **95628** Bearing Shield onto the balancer shaft so that the convex side is toward the hex portion of the balancer shaft.
 - c. Install the **56053** Bearing Seal so that it fits down completely over the shaft step.
 - d. Apply a small amount of the Loctite #271 (or equivalent) to the bearing surface of the **57262** Balancer Shaft.
 - e. Use the large end of the **57091** Bearing Press Tool along with the **96232**, #2 Arbor Press to push the **56133** Bearing onto the balancer shaft until the I.D. of the bearing sits against the shaft step. (Drawing 1)
2. Place the counterweight of the motor shaft balancer in a vise equipped with aluminum or bronze jaws so that the bearing pocket is pointing up.
3. Apply a small amount of the Loctite #271 (or equivalent) to the outside diameter of the **56133** Bearing. Slide the balancer shaft/bearing assembly all the way into the bearing pocket of the motor shaft balancer. Secure this assembly in the motor shaft balancer by squeezing the **95630** Snap Ring into the groove in the motor shaft balancer.
4. Install the **56046** Lock Ring onto the motor shaft balancer so that the "OFF" inscription is toward the counterweight of the shaft.
5. Use the small end of the **57091** Bearing Press Tool and the arbor press to install the **02695** Bearing all the way onto the motor shaft balancer. (Drawing 2)
6. Install the **54630** Front Bearing Plate onto the **02695** Bearing and check it for smooth rotation. (Drawing 3)
7. Install the **54673** Key so that the 90° side of the key fits into the keyway of the shaft and the tapered side of the key fits into the rotor. Install the **54705** Rotor/Blade Set (5) onto the motor shaft balancer.
8. Apply the **95842** Dynabrade Air Lube (10W/NR or equivalent) to the blades.
9. Install the **56595** Cylinder over the rotor so that the short line-up pin fits into the front bearing plate.
10. Place the **54629** Rear Bearing Plate over the shaft so that the long line-up pin fits through the hole in the rear bearing plate. Use the small end of the **57091** Bearing Press Tool to install the **01206** Bearing onto the motor shaft balancer and into the **54629** Rear Bearing Plate. Use the press tool and the arbor press to install these so that there is a snug fit between the bearing plates and the cylinder. **Note:** Carefully press the **01206** Bearing onto the motor shaft balancer until it touches against the bearing seat on the inside of the bearing plate. (Drawing 4)
11. Secure the counterweight of the motor shaft balancer in a vise equipped with aluminum or bronze jaws so that the motor assembly is pointing up.
12. Apply a small amount of the Loctite #271 to the threads of the motor shaft balancer and use a 26mm Crow Foot Wrench to install the **56713** Lock Assembly by turning it counterclockwise. (Left Hand Thread) (Torque to 12 N-m/100 in. lbs.) Install **96252** Spring, **56705** Cap and **57264** Post Assembly.
13. Orient the flat side of the **56705** Post Cap toward the flared end of **57264** Post Assembly and install the post cap. Install the **96252** Compression Spring onto the post assembly and insert the post assembly, with the spring and post cap into the motor shaft balancer.
14. Apply a small amount of petroleum lubricant to the **01020** O-Ring and install the o-ring into the air inlet hole in the cylinder.
15. Install the motor assembly into the housing making sure to align the line-up pin with the line-up hole that is on the inside of the housing.
16. Use the **56058** Lock Ring Tool to tighten the lock ring and secure the motor in the housing. (Torque to 34 N-m/300 in. lbs.)
17. Install the appropriate shroud and weight-mated sanding pad.

Motor Assembly Complete.

Handle and Valve Disassembly:

1. Place the **57092** Repair Collar around the housing so that the handle is pointing up.
2. Use a Phillips screwdriver to remove the four screws that fasten the handle to the housing. Carefully pull the handle from the housing. This provides access to the tip valve components, also the handle; o-ring, gasket and vacuum plug.
3. Use a 1/8" dia. flat end drive punch to remove the **95627** Pin and the **56582** Throttle Safety Lever.

(continued text and diagrams on next page)

4. Pull the 56578 Speed Regulator and valve stem out of the housing.
Handle and Valve Disassembly Complete.

Handle and Valve Assembly:

1. Place the 57092 Repair Collar around the housing so that the handle mounting area is facing up.
2. Install the 01025 O-Rings (3) onto the 56578 Speed Regulator, apply a small amount of petroleum lubricant to the o-rings and insert the regulator assembly into the housing. **Note:** Be careful that the o-rings do not get caught and pulled out of the o-ring grooves.
3. Install the 98459 O-Ring onto the 56579 Valve Stem, apply a small amount of petroleum lubricant to the o-ring and insert the shortest portion (from the end to the o-ring) of the valve stem assembly into the speed regulator.
4. Install the 56582 Throttle Safety Lever onto the housing and secure it in place with the 95627 Pin.
5. Install the 56598 Seal into the air inlet passage of the housing.
6. Install the 56586 Vacuum Plug into the exhaust passage of the housing. (See Exploded View)
7. Use needle-nose pliers to grasp and install the 51944 Tip Valve so that it fits under the 56579 Valve Stem.
8. Install the large end of the 51943 Spring into the air inlet passage of the handle.
9. Install the 56469 Gasket onto the mounting surface of the handle.
10. Apply a small amount of petroleum lubricant to the 96459 O-Ring and install it onto the outside diameter of the air inlet passage at the location of the first shoulder.
11. Connect the handle to the housing and secure it in place with the four screws. **Note:** The two longer screws, Part Number 96454 (2) also secure the 56591 Grip to the housing.
12. Install the 56597 Muffler and secure it in place with the 56596 Muffler Clip. (See Exploded View)

Handle and Valve Assembly Complete. Tool Assembly Complete. Please allow 30 minutes for adhesives to cure before operating tool.

Important: Motor should now be tested for proper operation at 90 PSIG. If motor does not operate properly or operates at a higher RPM than marked on the tool, the tool should be serviced to correct the cause before use. Before operating, place 2-3 drops of Dynabrade Air Lube (P/N 95842) directly into air inlet with throttle lever depressed. Operate tool for 30 seconds to determine if tool is operating properly and to allow lubricating oils to properly penetrate motor.

Loctite® is a registered trademark of Loctite Corp.

Diagrams

Drawing 1

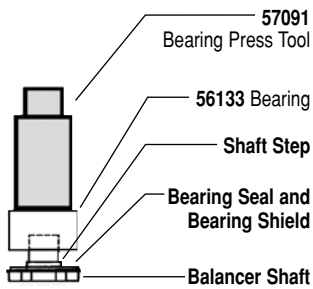

Drawing 2

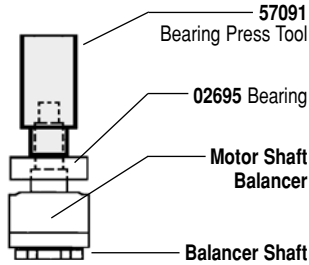

Important: Lock Ring must now be placed over sub-assembly. Not shown in drawings.

Drawing 3

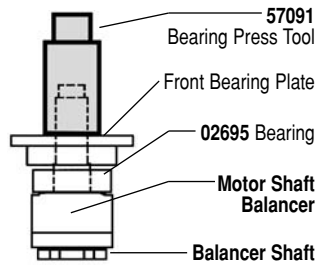

Drawing 4

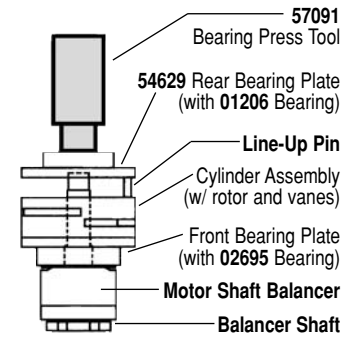

Optional Accessories



98220 Motor Tune-Up Kit

- Includes assorted parts to help maintain and repair motor.



96232 (#2) Arbor Press

- This arbor press is ideal for the disassembly and assembly of air motors.



96346 2" Bearing Separator

- Use the separator to remove gears and bearings.



Dynabrade Air Lube

- Formulated for pneumatic equipment.
- Absorbs up to 10% of its weight in water.
- Prevents rust and formation of sludge.
- Keeps pneumatic tools operating longer with greater power and less down time.

95842: 1 pt. (473 ml)

95843: 1 gal. (3.8 L)



57260 Motor Repair Kit:

- Contains special tools for disassembly/assembly of machine.



Dynalocke™ Dual Action Sander

12,000 RPM, 3/16" Orbit Air Motor and Machine Parts

Models:

58430 - 5" Pad, Non-Vac
58431 - 5" Pad, Vac-Ready

58435 - 6" Pad, Non-Vac
58436 - 6" Pad, Vac-Ready

! WARNING

Always operate, inspect and maintain this tool in accordance with the Safety Code for portable air tools (ANSI B186.1) and any other applicable safety codes and regulations. Please refer to Dynabrade's Warning/Safety Operating Instructions for more complete safety information.

Index Key

No.	Part #	Description
1		Sanding Pad: See Chart
2	57262	Balancer Shaft
3	95630	Snap Ring
4	95628	Bearing Shield
5	56053	Bearing Seal
6	56052	Bearing
7		Motor Shaft Balancer:
	57268	5"
	57269	6"
8	54673	Key
9	56046	Lock Ring
10	02695	Bearing
11	54630	Front Bearing Plate
12	54705	Rotor/Blade Set (5/pkg.)
13	56595	Cylinder (Includes: 95865 Pin)
14	01020	O-Ring
15	54629	Rear Bearing Plate
16	01206	Bearing
17	56713	Lock Assembly
18	96252	Compression Spring
19	56705	Post Cap
20	57264	Post Assembly
21	56712	Switch Bottom
22	96478	O-Ring
23	57369	Shroud
24		Housing: See Chart (Includes: 56591 Housing Grip and labels)
25	56711	Switch Top
26	96489	Screw
27	95627	Pin
28	56582	Safety Throttle Lever
29	98459	Valve Stem
30	56579	Speed Regulator
31	56578	Speed Regulator
32	01025	O-Ring (3)
33	56598	Seal
34	51944	Tip Valve
35	51943	Spring
36	56586*	Vacuum Plug
37	96459	O-Ring
38	56469	Exhaust Gasket
39	56468	Handle Assembly (Includes: 51938 Inlet Screen)
40	96469	Screw (2)
41	96454	Screw (2)
42	56597*	Muffler
43	56596*	Muffler Cap

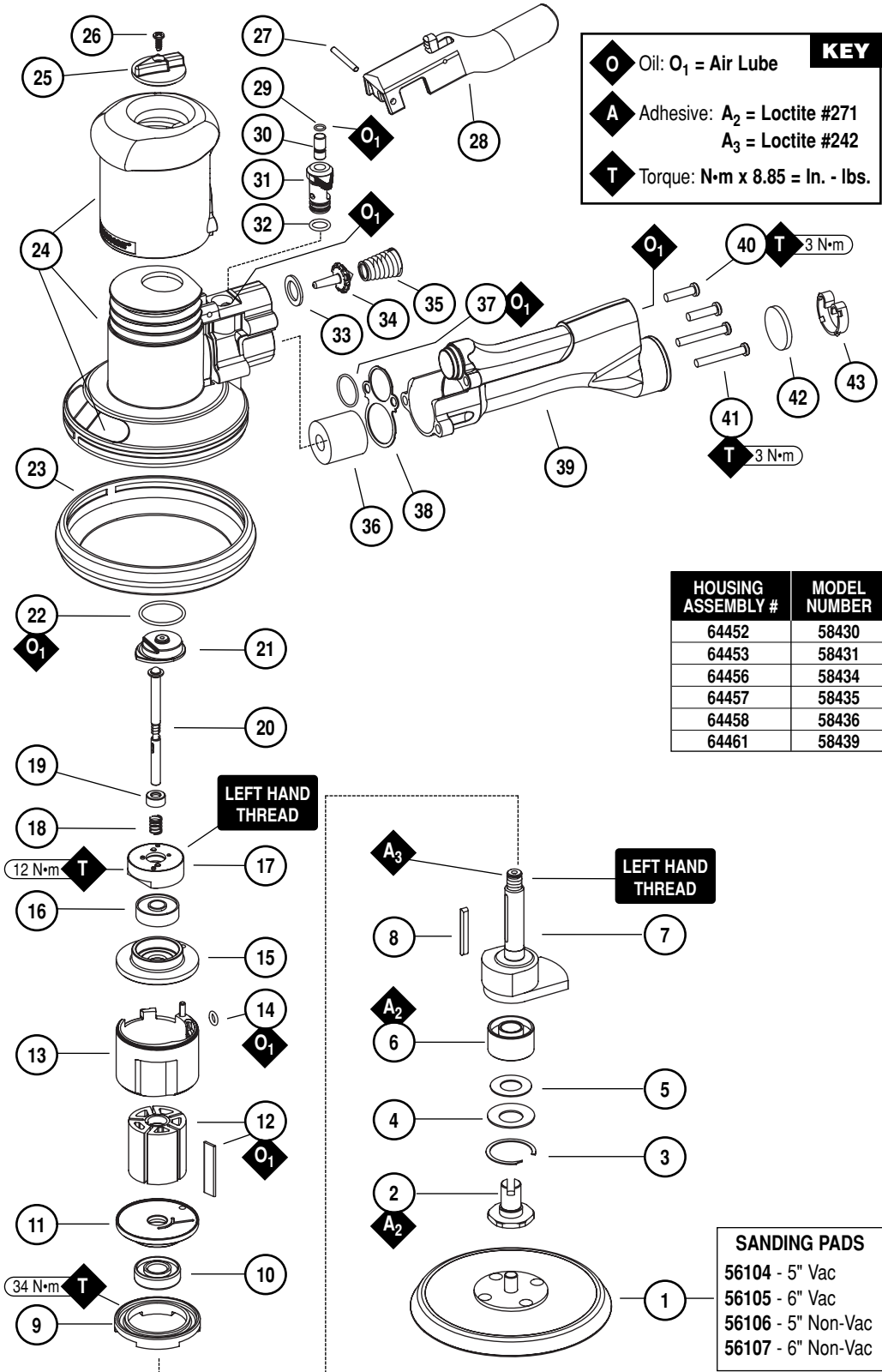

*Parts included with Non-Vacuum Models Only.

Important Operating, Maintenance and Safety Instructions

Carefully read all instructions before operating or servicing any Dynabrade® Abrasive Power Tool.

Warning: Hand, wrist and arm injury may result from repetitive work motion and overexposure to vibration.

Important: All Dynabrade Rotary Vane air tools must be used with a Filter-Regulator-Lubricator to maintain all warranties.

Operating Instructions:

Warning: Eye, face, respiratory, sound and body protection must be worn while operating power tools. Failure to do so may result in serious injury or death. Follow safety procedures posted in workplace.

1. With power source disconnected from tool, securely fasten abrasive/accessory on tool.
2. Install air fitting into inlet bushing of tool. **Important:** Secure inlet bushing of tool with a wrench before attempting to install the air fitting to avoid damaging valve body housing.
3. Connect power source to tool. Be careful not to depress throttle lever in the process.
4. Air tools are not intended for use in explosive atmospheres and are not insulated for contact with electrical power sources. Sanding/Grinding certain materials can create explosive dust. It is the employers responsibility to notify the user of acceptable dust levels. Sanding/Grinding can cause sparks which can cause fires or explosions. It is the users responsibility to make sure the work area is free of flammable materials.

Maintenance Instructions:

1. Check tool speed regularly with a tachometer. If tool is operating at a higher speed than the RPM marked on the tool, the tool should be serviced to correct the cause before use.
2. Some silencers on air tools may clog with use. Clean and replace as required.
3. All Dynabrade Rotary Vane air motors should be lubricated. Dynabrade recommends one drop of air lube per minute for each 20 SCFM (example: if the tool specifications state 40 SCFM, set the drip rate of your filter-lubricator at 2 drops per minute). Dynabrade Air Lube (P/N **95842**: 1 pt. 473 ml.) is recommended.
4. It is strongly recommended that all Dynabrade rotary vane air tools be used with a Filter-Regulator-Lubricator to minimize the possibility of misuse due to unclear air, wet air or insufficient lubrication. Dynabrade recommends the following: **11405** Air Line Filter-Regulator-Lubricator — Provides accurate air pressure regulation, two-stage filtration of water contaminants and micro-mist lubrication of pneumatic components. Operates 40 SCFM @ 100 PSIG has 3/8" NPT female ports.
5. Use only genuine Dynabrade replacement parts. To reorder replacement parts, specify the **Model #**, **Serial #**, and **RPM** of your machine.
6. A Motor Tune-Up Kit (P/N **98220**) is available which includes assorted parts to help maintain motor in peak operating condition. Please refer to Dynabrade's Preventative Maintenance Schedule for a guide to expectant life of component parts.
7. Mineral spirits are recommended when cleaning the tool and parts. Do not clean tool or parts with any solvents or oils containing acids, esters, keytones, chlorinated hydrocarbons or nitro carbons.
8. DO NOT clean or maintain air tools with chemicals that have a low flash point (example: WD-40®).

Safety Instructions:

Products offered by Dynabrade should not be converted or otherwise altered from original design without expressed written consent from Dynabrade, Inc.



- **Important:** User of tool is responsible for following accepted safety codes such as those published by the American National Standards Institute (ANSI).
- Always disconnect power supply before changing abrasive/accessory or making machine adjustments.
- Inspect abrasives/accessories for damage or defects prior to installation on tools.
- Please refer to Dynabrade's Warning/Safety Operating Instructions Tag (Reorder No. **95903**) for more complete safety information.

Notice

All Dynabrade motors use the highest quality parts and metals available and are machined to exacting tolerances. The failure of quality pneumatic motors can most often be traced to an unclean air supply or the lack of lubrication. Air pressure easily forces dirt or water contained in the air supply into motor bearings causing early failure. It often scores the cylinder walls and the rotor blades resulting in limited efficiency and power. Our warranty obligation is contingent upon proper use of our tools and cannot apply to equipment which has been subjected to misuse such as unclean air, wet air or a lack of lubrication during the use of this tool.

Full One Year Warranty

Following the reasonable assumption that any inherent defect which might prevail in a product will become apparent to the user within one year from the date of purchase, all equipment of our manufacture is warranted against defects in workmanship and materials under normal use and service. We shall repair or replace at our factory, any equipment or part thereof which shall, within one year after delivery to the original purchaser, indicate upon our examination to have been defective. Our obligation is contingent upon proper use of Dynabrade tools in accordance with factory recommendations, instructions and safety practices. It shall not apply to equipment which has been subject to misuse, negligence, accident or tampering in any way so as to affect its normal performance. Normally wearable parts such as bearings, contact wheels, rotor blades, etc., are not covered under this warranty.

Model Number	Motor hp (W)	Motor RPM	Pad Dia. Inch (mm)	Sound Level	Maximum Air Flow CFM/SCFM (LPM)	Hose I.D. Size Inch or (mm)	Air Inlet Thread	Tool Thread	Weight Pound (kg)	Length Inch (mm)	Height Inch (mm)
58430	.45 (336)	12,000	5 (127)	82 dB(A)	3/23 (651)	1/4 or (8)	1/4" NPT	5/16"-24 Female	2.7 (1.2)	11-1/16 (280)	5-1/8 (131)
58431	.45 (336)	12,000	5 (127)	82 dB(A)	3/23 (651)	1/4 or (8)	1/4" NPT	5/16"-24 Female	2.6 (1.2)	11-1/16 (280)	5-1/8 (131)
58435	.45 (336)	12,000	6 (152)	82 dB(A)	3/23 (651)	1/4 or (8)	1/4" NPT	5/16"-24 Female	2.8 (1.3)	11-1/2 (293)	5-1/8 (131)
58436	.45 (336)	12,000	6 (152)	85 dB(A)	3/23 (651)	1/4 or (8)	1/4" NPT	5/16"-24 Female	2.7 (1.2)	11-1/2 (293)	5-1/8 (131)

Additional Specifications: Air Pressure 90 PSIG (6.2 Bar)

Disassembly/Assembly Instructions

Important: The manufacturer's warranty is void if the tool is disassembled before the warranty expires. Use these instructions in conjunction with the Part Number 57260 Tool Repair Kit. This kit includes special tooling for the proper disassembly/assembly of the Two-Hand Dynalocke Sander. This Tooling will be referred to in these instructions. An air motor Tune-Up Kit, Part Number 99220 is also available. It contains the high and medium wear components that most commonly need replacement.

Motor Disassembly:

1. Disconnect the sander from the air supply.
2. Use the **57092** Repair Collar to hold the sander in a vise. Position the sander so that the sanding pad is facing up. **Note:** Do not over tighten the collar and sander in the vise. Only hold the sander snugly, so that the motor lock ring can be removed easily.
3. Use the **50679** 26mm Open End Wrench to remove the sanding pad from the sander by holding the **57262** Balancer Shaft stationary and turning the pad counterclockwise.
4. Use the **56058** Lock Ring Tool to remove the **56046** Lock Ring by turning it counterclockwise.
5. Pull the air motor assembly out of the housing. **Note:** Be aware that the **57264** Post Assembly, **56705** Post Cap, and **96252** Compression Spring will slip easily out of the motor shaft balancer.
6. Secure the counterweight of the motor shaft balancer in a vise equipped with aluminum or bronze jaws so that the motor assembly is pointing up.
7. Use the **50679**, 26mm Open End Wrench to remove the **56713** Lock Assembly by turning it clockwise. (Left Hand Threads)
8. Remove the **01020** O-Ring from the **56595** Cylinder and fasten a 2" bearing separator around the part of the cylinder that is closest to the **54629** Rear Bearing Plate.
9. Place the air motor with the bearing separator attached, onto the **96232**, #2 Arbor Press so that the counterweight is hanging down from the table of the arbor press.
10. Use a 5/16" dia. flat end drive punch as a press tool to push the motor shaft balancer out of the **01206** Bearing. Use the **96213** Bearing Removal Tool to push the **01206** Bearing out of the **54629** Rear Bearing Plate. **Note:** This bearing removal tool is not included in the **96283** Repair Kit.
11. Remove the cylinder, rotor, vanes, key and the **54630** Front Bearing Plate.
12. Use a 2" bearing separator and arbor press to remove the **02695** Bearing.
13. Fasten the counterweight of the motor shaft balancer in a vise equipped with aluminum or bronze jaws so that the **57262** Balancer Shaft is pointing up.
14. Use a small flat blade screwdriver to remove the **95630** Snap Ring.
15. Use the **56056** Bearing Puller to remove the balancer bearing assembly.
16. Fasten the separator between the **57262** Balancer Shaft and the **95628** Bearing Shield.
17. Place the bearing separator on the table of the arbor press so that the hex end of the **57262** Balancer Shaft is pointing down. Use the 3/16" flat end drive punch as a press tool to push the balancer shaft out of the **56052** Bearing. Remove the **56053** Bearing Seal and the **95628** Bearing Shield.

Motor Disassembly Complete.

Motor Assembly:

Important: Clean and inspect all motor parts for wear or defect.

1. Balancer Assembly:
 - a. Install the **95630** Snap Ring onto the **57262** Balancer Shaft.
 - b. Install the **95628** Bearing Shield onto the balancer shaft so that the convex side is toward the hex portion of the balancer shaft.
 - c. Install the **56053** Bearing Seal so that it fits down completely over the shaft step.
 - d. Apply a small amount of the Loctite #271 (or equivalent) to the bearing surface of the **57262** Balancer Shaft.
 - e. Orient the seal side of the **56052** Bearing toward the hex portion of the balancer shaft. Use the large end of the **57091** Bearing Press Tool along with the **96232**, #2 Arbor Press to push the **56052** Bearing onto the balancer shaft until the I.D. of the bearing sits against the shaft step. (Drawing 1)
2. Place the counterweight of the motor shaft balancer in a vise equipped with aluminum or bronze jaws so that the bearing pocket is pointing up.
3. Apply a small amount of the Loctite #271 (or equivalent) to the outside diameter of the **56052** Bearing. Slide the balancer shaft/bearing assembly all the way into the bearing pocket of the motor shaft balancer. Secure this assembly in the motor shaft balancer by squeezing the **95630** Snap Ring into the groove in the motor shaft balancer.
4. Install the **56046** Lock Ring onto the motor shaft balancer so that the "OFF" inscription is toward the counterweight of the shaft.
5. Use the small end of the **57091** Bearing Press Tool and the arbor press to install the **02695** Bearing all the way onto the motor shaft balancer. (Drawing 2)
6. Install the **54630** Front Bearing Plate onto the **02695** Bearing and check it for smooth rotation. (Drawing 3)
7. Install the **54673** Key so that the 90° side of the key fits into the keyway of the shaft and the tapered side of the key fits into the rotor. Install the **54705** Rotor/Blade Set (5) onto the motor shaft balancer.
8. Apply the **95842** Dynabrade Air Lube (10W/NR or equivalent) to the blades.
9. Install the **56595** Cylinder over the rotor so that the short line-up pin fits into the front bearing plate.
10. Place the **54629** Rear Bearing Plate over the shaft so that the long line-up pin fits through the hole in the rear bearing plate. Use the small end of the **57091** Bearing Press Tool to install the **01206** Bearing onto the motor shaft balancer and into the **54629** Rear Bearing Plate. Use the press tool and the arbor press to install these so that there is a snug fit between the bearing plates and the cylinder. **Note:** Carefully press the **01206** Bearing onto the motor shaft balancer until it touches against the bearing seat on the inside of the bearing plate. (Drawing 4)
11. Secure the counterweight of the motor shaft balancer in a vise equipped with aluminum or bronze jaws so that the motor assembly is pointing up.
12. Apply a small amount of the Loctite #271 to the threads of the motor shaft balancer and use a 26mm Crow Foot Wrench to install the **56713** Lock Assembly by turning it counterclockwise. (Left Hand Thread) (Torque to 12 N·m/100 in. lbs.) Install **96252** Spring, **56705** Cap and **57264** Post Assembly.
13. Orient the flat side of the **56705** Post Cap toward the flared end of **57264** Post Assembly and install the post cap. Install the **96252** Compression Spring onto the post assembly and insert the post assembly, with the spring and post cap into the motor shaft balancer.
14. Apply a small amount of petroleum lubricant to the **01020** O-Ring and install the o-ring into the air inlet hole in the cylinder.
15. Install the motor assembly into the housing making sure to align the line-up pin with the line-up hole that is on the inside of the housing.
16. Use the **56058** Lock Ring Tool to tighten the lock ring and secure the motor in the housing. (Torque to 34 N·m/300 in. lbs.)
17. Install the appropriate shroud and weight-mated sanding pad.

Motor Assembly Complete.

Handle and Valve Disassembly:

1. Place the **57092** Repair Collar around the housing so that the handle is pointing up.
2. Use a Phillips screwdriver to remove the four screws that fasten the handle to the housing. Carefully pull the handle from the housing. This provides access to the tip valve components, also the handle; o-ring, gasket and vacuum plug.
3. Use a 1/8" dia. flat end drive punch to remove the **95627** Pin and the **56582** Throttle Safety Lever.

(continued text and diagrams on next page)

4. Pull the 56578 Speed Regulator and valve stem out of the housing.
Handle and Valve Disassembly Complete.

Handle and Valve Assembly:

1. Place the 57092 Repair Collar around the housing so that the handle mounting area is facing up.
2. Install the 01025 O-Rings (3) onto the 56578 Speed Regulator, apply a small amount of petroleum lubricant to the o-rings and insert the regulator assembly into the housing. **Note:** Be careful that the o-rings do not get caught and pulled out of the o-ring grooves.
3. Install the 98459 O-Ring onto the 56579 Valve Stem, apply a small amount of petroleum lubricant to the o-ring and insert the shortest portion (from the end to the o-ring) of the valve stem assembly into the speed regulator.
4. Install the 56582 Throttle Safety Lever onto the housing and secure it in place with the 95627 Pin.
5. Install the 56598 Seal into the air inlet passage of the housing.
6. Install the 56586 Vacuum Plug into the exhaust passage of the housing. (See Exploded View)
7. Use needle-nose pliers to grasp and install the 51944 Tip Valve so that it fits under the 56579 Valve Stem.
8. Install the large end of the 51943 Spring into the air inlet passage of the handle.
9. Install the 56469 Gasket onto the mounting surface of the handle.
10. Apply a small amount of petroleum lubricant to the 96459 O-Ring and install it onto the outside diameter of the air inlet passage at the location of the first shoulder.
11. Connect the handle to the housing and secure it in place with the four screws. **Note:** The two longer screws, Part Number 96454 (2) also secure the 56591 Grip to the housing.
12. Install the 56597 Muffler and secure it in place with the 56596 Muffler Clip. (See Exploded View)

Handle and Valve Assembly Complete. Tool Assembly Complete. Please allow 30 minutes for adhesives to cure before operating tool.

Important: Motor should now be tested for proper operation at 90 PSIG. If motor does not operate properly or operates at a higher RPM than marked on the tool, the tool should be serviced to correct the cause before use. Before operating, place 2-3 drops of Dynabrade Air Lube (P/N 95842) directly into air inlet with throttle lever depressed. Operate tool for 30 seconds to determine if tool is operating properly and to allow lubricating oils to properly penetrate motor.

Loctite® is a registered trademark of Loctite Corp.

Diagrams

Drawing 1

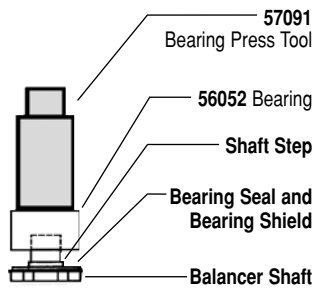

Drawing 2

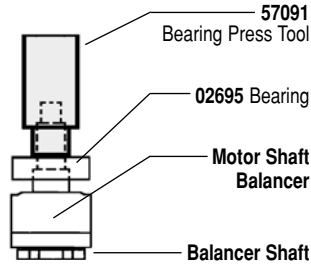

Important: Lock Ring must now be placed over sub-assembly. Not shown in drawings.

Drawing 3

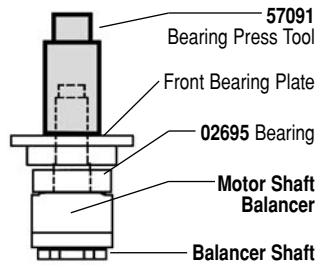

Drawing 4

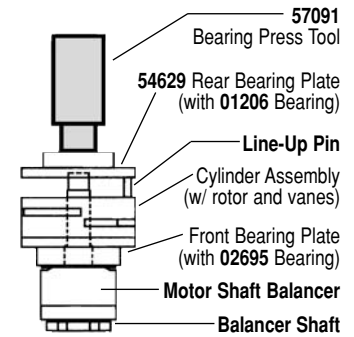

Optional Accessories



98220 Motor Tune-Up Kit

- Includes assorted parts to help maintain and repair motor.



96232 (#2) Arbor Press

- This arbor press is ideal for the disassembly and assembly of air motors.



96346 2" Bearing Separator

- Use the separator to remove gears and bearings.



Dynabrade Air Lube

- Formulated for pneumatic equipment.
 - Absorbs up to 10% of its weight in water.
 - Prevents rust and formation of sludge.
 - Keeps pneumatic tools operating longer with greater power and less down time.
- 95842: 1 pt. (473 ml)
95843: 1 gal. (3.8 L)



57260 Motor Repair Kit:

- Contains special tools for disassembly/assembly of machine.