

Models:

- 57400 - Non-Vac**
- 57401 - Vac-Ready**
- 57402 - Basic Vac**
- 57403 - Deluxe Vac**
- 57404 - Central Vac-Ready**
- 57405 - Versatility Kit**
- 57407 - Non-Vac, w/clips**

Dynaline Sander

*For Serial Number 513366 and Higher
 Palm-Style, Air Powered, 2,400 SPM*

WARNING

Always operate, inspect and maintain this tool in accordance with the Safety Code for portable air tools (ANSI B186.1) and any other applicable safety codes and regulations. Please refer to Dynabrade's Warning/Safety Operating Instructions for more complete safety information.

Index Key

No.	Part #	Description
1	57429	Felt Seal (4)
2	95885	Screw (2)
3	01211	Lock Washer (2)
4	Slide Board	
	57433	Non-Vacuum
	57432	Vacuum
5	57431	Transfer Pinion (2)
6	57427	Slider Housing Assembly (2) (Incl. 57429 Felt Seal)
7	95641	Nut (2)
8	95642	Screw (2)
9	57434	Vac Adapter (Vac Only)
10	57445	Needle Bearing
11	57430	Cam Assembly
12*	96027	Screw (4)
13*	57439	Rail (2)
14*	57438	Counter Weight
15	01139	Bearing (3)
16	95593	Set Screw
17	54467	Retaining Ring
18	54468	Ring Gear
19	54465	Planetary Carrier
20	06213	Gears (2)
21	54475	Shaft (2)
22	07146	Packing
23	57059	Lock Ring
24	95973	Washer
25	57055	Front Ring
26	57437	Front Bearing Plate
27	56047	Rotor Key
28	54470	Rotor Pinion
29	57113	Rotor/Blade Set
30	57058	Cylinder Assembly (Incl. 95971 Line-Up Pin)
31	95971	Line-Up Pin
32	57056	Rear Bearing Plate
33	01206	Bearing
34	57054	Rear Ring
35	94590	Pin
36	57041	Comfort Platform
37	57441	Lever
38	95697	Retaining Ring
39	01025	O-Ring (2)
40	01477	Valve Stem
41	57064	Speed Regulator or 57053 Recessed Speed Reg.
42	01464	Seal
43	01472	Tip Valve
44	01468	Spring
45	01494	Inlet Bushing

KEY	
	Oil: O ₁ = Air Lube
	Adhesive: A ₂ = Loctite #271 A ₈ = Loctite #567
	Torque: N•m x 8.85 = In. - lbs.
	Grease: G ₁ = Lubriplate 630AA

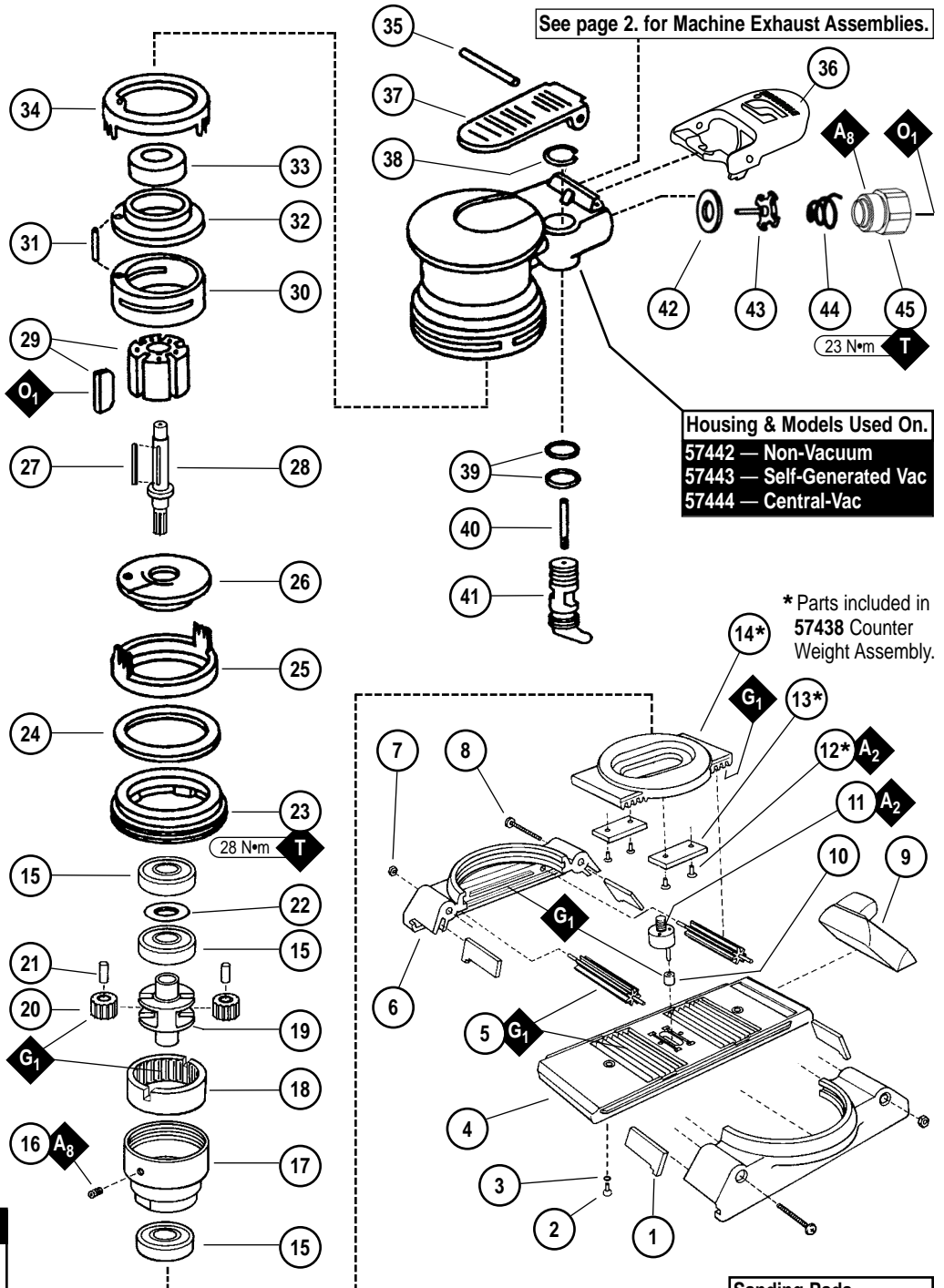

Note: To order replacement parts specify the model and serial number of your machine.

Sanding Pads	
57454	Non-Vacuum
57455	Vacuum
57460	With Clips
57852	Non-Vacuum Hook-Face

Machine Exhaust Assemblies

Non-Vacuum/Machine Exhaust

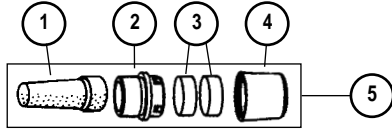

Self Generated Vacuum (Vac-Ready) / Machine Exhaust

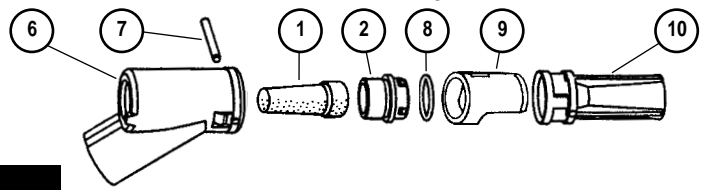

Central Vacuum/Machine Exhaust

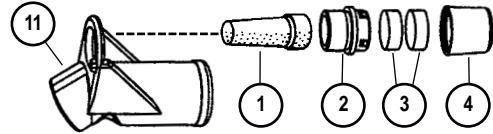

Index Key

No.	Part #	Description	No.	Part #	Description
1	57065	Cone Plug	7	96197	Dowel Pin
2	57066	Muffler Cap	8	95526	O-Ring
3	56027	Muffler Insert (2)	9	59088	Vac Nozzle
4	56028	Muffler Cap	10	57067	Vac Tube
5	57124	Muffler Assembly	11	57093	Vacuum Adapter
6	57083	Vacuum Adapter			

Important Operating, Maintenance and Safety Instructions

Carefully read all instructions before operating or servicing any Dynabrade® Abrasive Power Tool.

Warning: Hand, wrist and arm injury may result from repetitive work motion and overexposure to vibration.

Important: All Dynabrade rotary vane air tools must be used with a Filter-Regulator-Lubricator to maintain all warranties.

Operating Instructions:

Warning: Eye, face, respiratory, sound and body protection must be worn while operating power tools. Failure to do so may result in serious injury or death. Follow safety procedures posted in workplace.

1. With power source disconnected from tool, securely fasten abrasive/accessory on tool.
2. Connect power source to tool. Be careful **not** to depress throttle lever in the process.
3. Check tool speed with tachometer. If tool is operating at a higher speed than the SPM marked on the tool or operating improperly, the tool should be serviced to correct the cause before use.

Maintenance Instructions:

Products offered by Dynabrade should not be converted or otherwise altered from original design without expressed written consent from Dynabrade, Inc.

1. All Dynabrade rotary vane air motors should be lubricated. Dynabrade recommends one drop of air lube per minute for each 20 SCFM (example: if the tool specifications state 40 SCFM, set the drip rate of your filter-lubricator at 2 drops per minute). Dynabrade Air Lube (P/N 95842: 1 pt. 473 ml.) is recommended.
2. Mineral spirits are recommended when cleaning tool. Do not clean tool with any solvents or oils containing concentrated acids, esters, ketones chlorinated hydrocarbons or nitro hydrocarbons.
3. An Air Line Filter-Regulator-Lubricator must be used with this air tool to maintain all warranties. Dynabrade recommends the following: **10681** Air Line Filter-Regulator-Lubricator — Provides accurate air pressure regulation, two-stage filtration of water contaminants and micro-mist lubrication of pneumatic components. Operates 55 SCFM @ 100 PSIG has 1/2" NPT female ports.
4. Frequent drainage of water traps in air lines is recommended.
5. Some silencers on air tools may clog with use. Clean and replace as required.
6. A Motor Tune-Up Kit (P/N 96107) is available which includes assorted parts to help maintain and repair motor.

Safety Instructions:

- **Warning:** Eye, face, respiratory, sound and body protection must be worn while operating power tools. Failure to do so may result in serious injury or death. Follow safety procedures posted in workplace.
- **Important:** User of tool is responsible for following accepted safety codes such as those published by the American National Standards Institute (ANSI).
- Tool SPM must never exceed abrasive/sanding pad SPM rating, regardless of tool capacity.
- Operate machine for 30 seconds before application to workpiece to determine if machine is safely performing before work begins.
- Always disconnect power supply before changing abrasive or making machine adjustments.
- Inspect abrasives and sanding pads for damage or defects prior to and during operation of tool.
- Please refer to Dynabrade's Warning/Safety Operating Instructions Tag (Reorder No. 95903) for more complete safety information.
- **Warning:** Hand, wrist and arm injury may result from repetitive work, motion and overexposure to vibration.

Lifetime Warranty

All Dynabrade portable pneumatic power tools are rigorously inspected and performance tested in our factory before shipping to our customers. If a Dynabrade tool develops a performance problem and an inherent defect is found during normal use and service, Dynabrade will warrant this tool against defects in workmanship and materials for the lifetime of the tool. Upon examination and review at our factory, Dynabrade shall confirm that the tool qualifies for warranty status, and will repair or replace the tool at no charge to the customer. Normally wearable parts and products are NOT covered under this warranty. Uncovered items include bearings, contact wheels, rotor blades, regulators, valve stems, levers, shrouds, guards, O-rings, seals, gaskets and other wearable parts. Dynabrade's warranty policy is contingent upon proper use of our tools in accordance with factory recommendations, instructions and safety practices. It shall not apply to equipment that has been subjected to misuse, negligence, accident or tampering in any way so as to affect its normal performance. Dynabrade will not honor lifetime warranty on unregistered tools. A one-year warranty will be honored on all unregistered portable pneumatic power tools. Lifetime warranty applies only to portable pneumatic tools manufactured by Dynabrade, Inc. in the USA. Lifetime warranty applies only to the original tool owner; warranty is non-transferable.

Disassembly/Assembly Instructions – Dynaline Sander

Important: Manufacturer's warranty is void if tool is disassembled before warranty expires.

A complete Tune-Up Kit, (P/N **96107**), is available which includes assorted parts to maintain and repair motor. A Motor Repair Kit (P/N **96046**) is available which contains special tools for disassembly/assembly of machine.

Gearbox Disassembly:

1. Disconnect tool from power source.
2. Invert machine and secure in vice, using **57092** Collar (Supplied in **96046** Repair Kit) or padded jaw.
3. Disconnect sanding pad by removing **95885** Screws (2) with a 3mm Hex Key.
4. Remove gearbox assembly by removing **95642** Screws (2) and **95641** Hex Nuts with a phillips head screw driver.
5. Carefully separate **57427** Slider Housing halves. Remove one gearbox half, making sure no parts fall to the ground.
6. Remove and set aside the **57433** Slide-Board on non-vacuum models (**57432** on vacuum models), **57431** Transfer Pinion (2), **57438** Counterweight Assembly, **57445** Needle Bearing and the other **57427** Slider Housing half.
7. Clean grease off old dirty components and inspect for damaged parts.

Motor Disassembly:

1. Insert **56058** Lock Ring Wrench (Supplied in **96046** Repair Kit) into corresponding tabs of lock ring and unscrew. Pull with a side to side action to remove motor from housing. Remove **57054** Rear Ring, **57055** Front Ring, **95973** Washer, and **57059** Lock Ring. Motor may now be serviced.
2. Remove **54467** Retaining Ring/Planetary Gear Assembly using (2) **50679** 26mm wrenches (Supplied in **96046** Repair Kit). Set aside.
Note: See planetary gear disassembly.
3. Remove **57056** Rear Plate By holding **57058** Cylinder with a 2" Bearing Separator and pressing **54470** Rotor Pinion out of **01206** Bearing.
4. Remove **57113** Blade (5), rotor set and **56047** Rotor Key.
5. Disassemble **57437** Front Plate by pressing **54470** Rotor Pinion through front plate. **Note:** One **01139** Bearing will remain on rotor pinion. To remove press pinion through remaining bearing.
6. Press **01206** Rear Bearing from **57056** Bearing Plate.

Planetary Gear Disassembly:

1. Insert **54470** Rotor Pinion into the center of the planetary gear assembly. Install the **56047** Rotor Key into the key way of the rotor pinion, and hold the rotor pinion in a soft jaws vise.
2. Place a 26mm wrench on the flats of the **54467** Retaining Ring and an adjustable 3mm pin spanner wrench into the two empty holes on the **57430** Cam Assembly. Turn counterclockwise to loosen and remove the cam assembly.
3. Remove **95593** Set Screw from Retaining Ring/Planetary Gear Assembly using a 5/64" allen wrench.
4. Remove **54465** Planetary Carrier by pressing out from **01139** Bearing. **02613** Gears (2) and **54475** Shafts (2) can now be removed from planetary carrier.
5. Remove **54468** Ring Gear by tapping retaining ring on a hard surface. Once the ring slides towards the front, it will be necessary to use your fingers to remove it the rest of the way.
Note: If hard to remove, heat may be applied to retaining ring and pliers used to remove gear.
6. Press **01139** Bearing from **54467** Retaining Ring.

Motor Disassembly Complete.

Planetary Gear Assembly:

Important: Be certain all parts are cleaned, properly greased and in good repair before assembling.

1. Press **01139** Bearing into **54467** Retaining Ring.
2. Place **54468** Ring Gear into **54467** Retaining Ring lining up one of the notches with set screw hole.
3. Hand tighten **95593** Set Screw in place using 5/64" hex key.
4. Install lightly greased Planetary Carrier. Place **54475** Shafts into gears.
5. Slide entire Planetary Carrier Assembly into **54467** Retaining Ring (1/4"-28 female thread facing down).
6. Insert **54470** Rotor Pinion into the center of the planetary gear assembly. Install **56047** Rotor Key into the key way of the rotor pinion.
7. Apply 1 drop of #271 Loctite® (or equivalent) to the threads of **57430** Cam Assembly.
8. Place a 26mm wrench on the flats of the **54467** Retaining Ring and an adjustable 3mm pin spanner wrench into the two empty holes on the **57430** Cam Assembly. Turn clockwise to install the cam assembly.

Motor Assembly:

1. Press **01139** Bearing onto Rotor Pinion until seated against shoulder as shown in Drawing 1.
2. Press assembly into **57437** Front Bearing Plate as shown in Drawing 2 and check for smooth rotation.
3. Place **07146** Packing in front plate bore and press **01139** Bearing into bore onto packing as shown in Drawing 3.
4. Invert rotor pinion in support. Install **56047** Rotor Key and **57113** Blade and Rotor Set onto rotor pinion.
Note: Blades should be lightly lubricated with Dynabrade Air Lube P/N **95842** (or equivalent) before installation.
5. Place **57058** Cylinder Assembly over rotor. The "short" line-up pin goes toward the front plate.
6. Place **57056** Rear Plate (with **01206** Bearing pressed into place) over shaft and "long" end of line-up pin. Press fit in place as shown in Drawing 4.

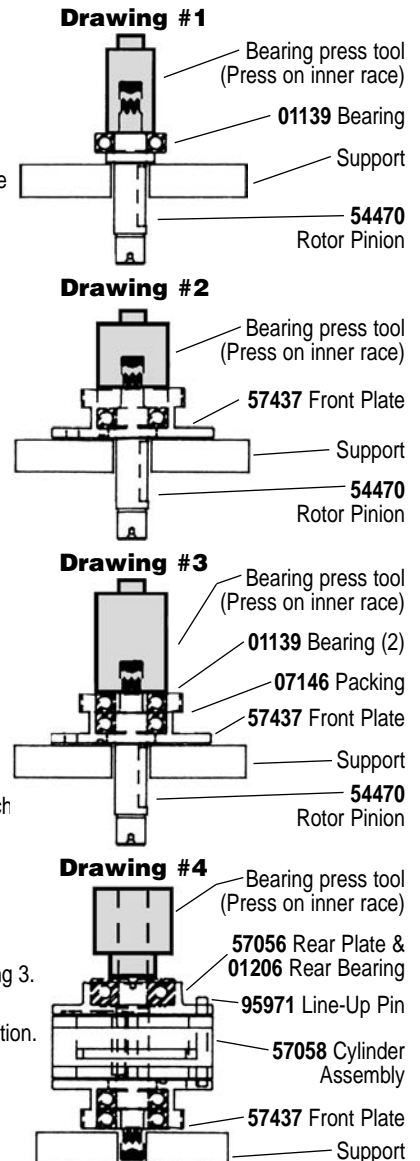

(continued on next page)

Disassembly/Assembly Instructions – Dynaline Sander (continued)

- Place **57054** Rear Ring over the rear plate and line-up pin. Turn the motor over and place **57055** Front Ring over the front plate making sure the “legs and fingers” on the front and rear rings line-up.
Note: The small cut-outs on both rings should line-up with the square holes in the cylinder/end plate assembly.
- Place **95973** Washer and **57059** Lock Ring onto the front ring with one drop of pneumatic tool oil spread between the washer and the lock ring.
- Secure motor housing in vice, using **57092** Collar or padded jaws. Spread 2-3 drops of pneumatic tool oil around the housing bore for ease of insertion of motor assembly. Slide motor assembly into secured housing.
Note: Be certain line-up pin enters the pocket in the bottom of the housing and the “legs” of the rings stay in-line.
- Tighten lock ring with **56058** Lock Ring Tool to 28 N•m/250 in. - lbs.

Gearbox Assembly:

- Place **57428** Sliders in gearbox halves.
- Install **57429** Felt Seals into gear housing halves. Using Dynabrade’s **95542** Gear Grease (or equivalent), grease entire slider including, transfer pinion holes and groves.
- Grease slide board gear pack and bearing pocket. Grease **57445** Bearing. Place bearing on **57430** Cam Assembly. Grease counterweight gear packs.
- Place counterweight over **57430** Cam Assembly with tool inverted and exhaust at six o'clock. Place cam assembly bearing at three o'clock. Take one gear box half and slide it onto the housing groves.
- Place transfer pinion on counter weight gear rack, sliding pinion shaft partially into mated hole on slider. Repeat for second shaft.
Important: Make sure counter weight is positioned dead center of cam assembly when transfer pinions are installed. This ensures correct timing.
- Making sure needle bearing is still located at three o'clock, place slide board railing into groove on slider while aligning needle bearing into bearing channel on slider board.
- Place other gearbox half onto grooves of motor housing, making sure all parts align. Press both gear box halves together.
- Install **95842** Screws and **95841** Nuts and tighten. Install Pad.

Valve And Speed Regulator Disassembly/Assembly:

- Secure housing in vice using **57092** Collar or padded jaw.
- Remove inlet bushing, **01468** Spring, **01472** Tip Valve, and **01464** Seal from housing.
- Remove **95697** Snap Ring. Press the **57064** Speed Regulator and **01447** Valve Stem out of the housing. Remove the **01025** O-Rings (2).
- Place new **01025** O-Rings (2) on the speed regulator and place in housing with valve stem. Install new **95967** Snap Ring.
- Place **01464** Seal in housing so the pocket of seal sets horizontal and towards the top of the tool. Using a pair of tweezers or needle nose pliers, place the tip valve in the housing so that its pin goes into the valve stem hole and the hinge seats into the pocket of the seal. Place **01468** Spring into the housing small end first.
- Spread one drop of # 271 Loctite® (or equivalent) around the first threads of the inlet bushing and tighten into housing to 23 N•m/200 in. - lbs.

Tool Assembly Complete. Please allow 30 minutes for adhesives to cure before operating tool.

Important: Motor should now be tested for proper operation at 90 PSIG. If motor does not operate properly or operates at a higher RPM than marked on the tool, the tool should be serviced to correct the cause before use. Before operating, place 2-3 drops of Dynabrade Air Lube (P/N **95842**) directly into air inlet with throttle lever depressed. Operate tool for 30 seconds to determine if tool is operating properly and to allow lubricating oils to properly penetrate motor.

Loctite® is a registered trademark of Loctite Corp.

Notice:

All Dynabrade motors use the highest quality parts and metals available and are machined to exacting tolerances. The failure of quality pneumatic motors can most often be traced to an unclean air supply or the lack of lubrication. Air pressure easily forces dirt or water contained in the air supply into motor bearings causing early failure. It often scores the cylinder walls and the rotor blades resulting in limited efficiency and power. Our warranty obligation is contingent upon proper use of our tools and cannot apply to equipment which has been subjected to misuse such as unclean air, wet air or a lack of lubrication during the use of this tool.

Note: To order replacement parts specify the model and serial number of your machine.

Model Number	Motor hp (W)	Motor RPM	Sound Level	Maximum Air Flow SCFM (LPM)	Air Pressure PSIG (Bars)	Weight Pound (kg)	Length Inch (mm)	Height Inch (mm)
All Models	.3 (186)	N/A	84-85 dB(A)	18 (510)	90 (6.2)	2.6 (1.2)	7 (178)	3-3/4 (95)

Additional Specifications: Air Inlet Thread 1/4" NPT • Hose Size 1/4" or 6mm

Optional Accessories



Grease and Grease Gun

- Multi-purpose grease for all types of bearing, cams, gears.
- High film strength; excellent resistance to water, steam, etc.
- Workable range 0°F to 300°F.

95541: Push-type grease gun.

95542: 10oz. (283.5g) tube.



96107 Motor Tune-Up Kit:

- Includes assorted parts to help maintain and repair motor.



96107 Tune-Up Kit

For Use With All:

Palm Style Planetary Geared Sanders & Buffers

Air Motor and Machine Parts

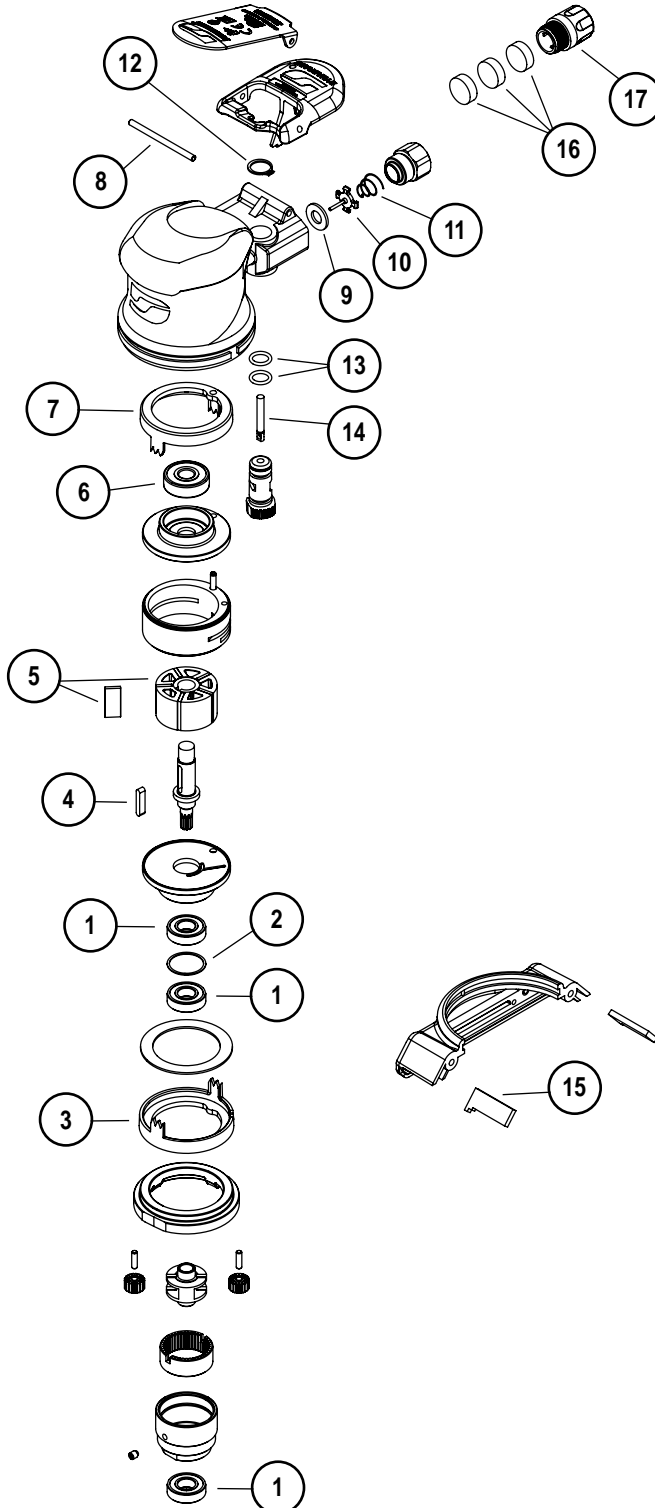

Parts included in tune-up kit are identified by part number.

Please refer to appropriate tool manual for additional identification and disassembly/assembly instructions.

ITEM	P/N	DESCRIPTION	QTY.
1	01139	BEARING	3
2	07146	PACKING	1
3	57055	FRONT RING	1
4	56047	ROTOR KEY	1
5	57113	ROTOR/VANE ASSEMBLY	1
6	01206	BEARING	1
7	57054	REAR RING	1
8	95979 94590	PIN - SHORT PIN - LONG	1
9	01464	SEAL	1
10	01472	TIP VALVE	1
11	01468	SPRING	1
12	95697	SNAP RING	1
13	01025	O-RING	2
14	01477	VALVE STEM	1
15	57429	FELT SEAL	4
16	56027	MUFFLER INSERT	3
17	69359	MUFFLER BODY	1

Models:

- 57400 - Non-Vac**
- 57401 - Vac-Ready**
- 57402 - Basic Vac**
- 57403 - Deluxe Vac**
- 57404 - Central Vac-Ready**
- 57405 - Versatility Kit**
- 57407 - Non-Vac, w/clips**

Dynaline Sander

*For Serial Number 513366 and Higher
 Palm-Style, Air Powered, 2,400 SPM*

WARNING

Always operate, inspect and maintain this tool in accordance with the Safety Code for portable air tools (ANSI B186.1) and any other applicable safety codes and regulations. Please refer to Dynabrade's Warning/Safety Operating Instructions for more complete safety information.

Index Key

No.	Part #	Description
1	57429	Felt Seal (4)
2	95885	Screw (2)
3	01211	Lock Washer (2)
4	Slide Board	
	57433	Non-Vacuum
	57432	Vacuum
5	57431	Transfer Pinion (2)
6	57427	Slider Housing Assembly (2) (Incl. 57429 Felt Seal)
7	95641	Nut (2)
8	95642	Screw (2)
9	57434	Vac Adapter (Vac Only)
10	57445	Needle Bearing
11	57430	Cam Assembly
12*	96027	Screw (4)
13*	57439	Rail (2)
14*	57438	Counter Weight
15	01139	Bearing (3)
16	95593	Set Screw
17	54467	Retaining Ring
18	54468	Ring Gear
19	54465	Planetary Carrier
20	06213	Gears (2)
21	54475	Shaft (2)
22	07146	Packing
23	57059	Lock Ring
24	95973	Washer
25	57055	Front Ring
26	57437	Front Bearing Plate
27	56047	Rotor Key
28	54470	Rotor Pinion
29	57113	Rotor/Blade Set
30	57058	Cylinder Assembly (Incl. 95971 Line-Up Pin)
31	95971	Line-Up Pin
32	57056	Rear Bearing Plate
33	01206	Bearing
34	57054	Rear Ring
35	94590	Pin
36	57041	Comfort Platform
37	57441	Lever
38	95697	Retaining Ring
39	01025	O-Ring (2)
40	01477	Valve Stem
41	57064	Speed Regulator or 57053 Recessed Speed Reg.
42	01464	Seal
43	01472	Tip Valve
44	01468	Spring
45	01494	Inlet Bushing

Symbol	Description
O	Oil: O ₁ = Air Lube
A	Adhesive: A ₂ = Loctite #271 A ₈ = Loctite #567
T	Torque: N•m x 8.85 = In. - lbs.
G	Grease: G ₁ = Lubriplate 630AA

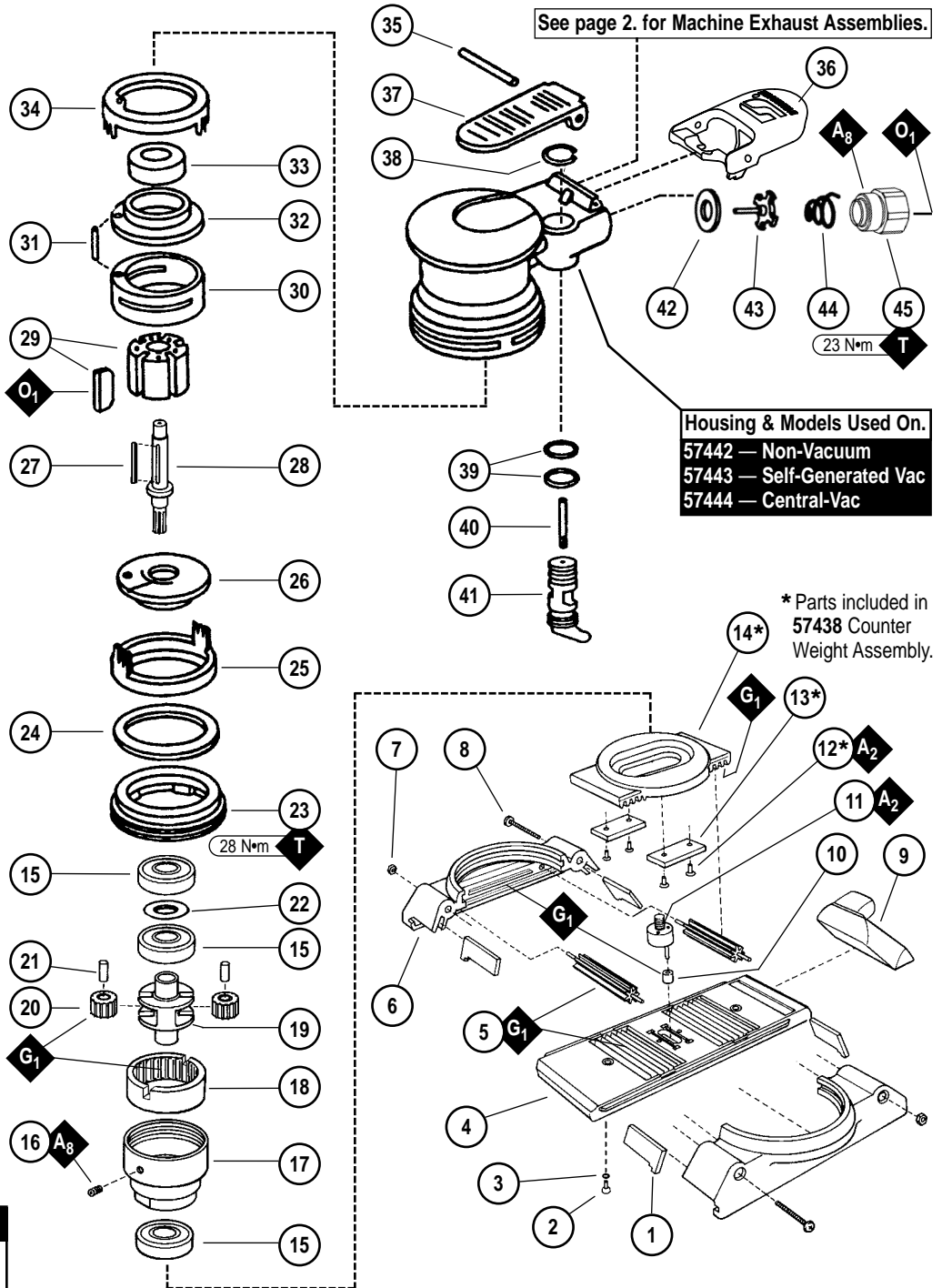

Note: To order replacement parts specify the model and serial number of your machine.

Machine Exhaust Assemblies

Non-Vacuum/Machine Exhaust

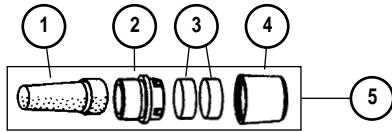

Self Generated Vacuum (Vac-Ready) / Machine Exhaust

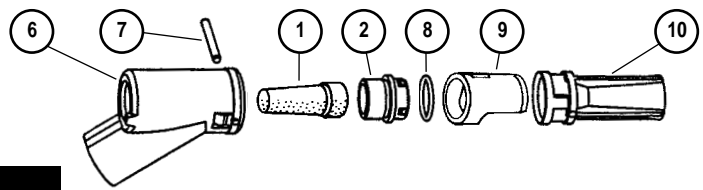

Index Key

No.	Part #	Description
1	57065	Cone Plug
2	57066	Muffler Cap
3	56027	Muffler Insert (2)
4	56028	Muffler Cap
5	57124	Muffler Assembly
6	57083	Vacuum Adapter
7	96197	Dowel Pin
8	95526	O-Ring
9	59088	Vac Nozzle
10	57067	Vac Tube
11	57093	Vacuum Adapter

Central Vacuum/Machine Exhaust

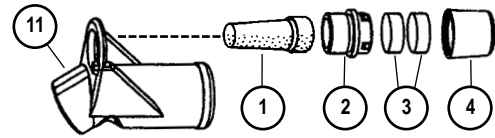

Important Operating, Maintenance and Safety Instructions

Carefully read all instructions before operating or servicing any Dynabrade® Abrasive Power Tool.

Warning: Hand, wrist and arm injury may result from repetitive work motion and overexposure to vibration.

Important: All Dynabrade rotary vane air tools must be used with a Filter-Regulator-Lubricator to maintain all warranties.

Operating Instructions:

Warning: Eye, face, respiratory, sound and body protection must be worn while operating power tools. Failure to do so may result in serious injury or death. Follow safety procedures posted in workplace.

1. With power source disconnected from tool, securely fasten abrasive/accessory on tool.
2. Connect power source to tool. Be careful **not** to depress throttle lever in the process.
3. Check tool speed with tachometer. If tool is operating at a higher speed than the SPM marked on the tool or operating improperly, the tool should be serviced to correct the cause before use.

Maintenance Instructions:

Products offered by Dynabrade should not be converted or otherwise altered from original design without expressed written consent from Dynabrade, Inc.

1. All Dynabrade rotary vane air motors should be lubricated. Dynabrade recommends one drop of air lube per minute for each 20 SCFM (example: if the tool specifications state 40 SCFM, set the drip rate of your filter-lubricator at 2 drops per minute). Dynabrade Air Lube (P/N 95842: 1 pt. 473 ml.) is recommended.
2. Mineral spirits are recommended when cleaning tool. Do not clean tool with any solvents or oils containing concentrated acids, esters, ketones chlorinated hydrocarbons or nitro hydrocarbons.
3. An Air Line Filter-Regulator-Lubricator must be used with this air tool to maintain all warranties. Dynabrade recommends the following: **10681** Air Line Filter-Regulator-Lubricator — Provides accurate air pressure regulation, two-stage filtration of water contaminants and micro-mist lubrication of pneumatic components. Operates 55 SCFM @ 100 PSIG has 1/2" NPT female ports.
4. Frequent drainage of water traps in air lines is recommended.
5. Some silencers on air tools may clog with use. Clean and replace as required.
6. A Motor Tune-Up Kit (P/N 96107) is available which includes assorted parts to help maintain and repair motor.

Safety Instructions:

- **Warning:** Eye, face, respiratory, sound and body protection must be worn while operating power tools. Failure to do so may result in serious injury or death. Follow safety procedures posted in workplace.
- **Important:** User of tool is responsible for following accepted safety codes such as those published by the American National Standards Institute (ANSI).
- Tool SPM must never exceed abrasive/sanding pad SPM rating, regardless of tool capacity.
- Operate machine for 30 seconds before application to workpiece to determine if machine is safely performing before work begins.
- Always disconnect power supply before changing abrasive or making machine adjustments.
- Inspect abrasives and sanding pads for damage or defects prior to and during operation of tool.
- Please refer to Dynabrade's Warning/Safety Operating Instructions Tag (Reorder No. 95903) for more complete safety information.
- **Warning:** Hand, wrist and arm injury may result from repetitive work, motion and overexposure to vibration.

Lifetime Warranty

All Dynabrade portable pneumatic power tools are rigorously inspected and performance tested in our factory before shipping to our customers. If a Dynabrade tool develops a performance problem and an inherent defect is found during normal use and service, Dynabrade will warrant this tool against defects in workmanship and materials for the lifetime of the tool. Upon examination and review at our factory, Dynabrade shall confirm that the tool qualifies for warranty status, and will repair or replace the tool at no charge to the customer. Normally wearable parts and products are NOT covered under this warranty. Uncovered items include bearings, contact wheels, rotor blades, regulators, valve stems, levers, shrouds, guards, O-rings, seals, gaskets and other wearable parts. Dynabrade's warranty policy is contingent upon proper use of our tools in accordance with factory recommendations, instructions and safety practices. It shall not apply to equipment that has been subjected to misuse, negligence, accident or tampering in any way so as to affect its normal performance. Dynabrade will not honor lifetime warranty on unregistered tools. A one-year warranty will be honored on all unregistered portable pneumatic power tools. Lifetime warranty applies only to portable pneumatic tools manufactured by Dynabrade, Inc. in the USA. Lifetime warranty applies only to the original tool owner; warranty is non-transferable.

Disassembly/Assembly Instructions – Dynaline Sander

Important: Manufacturers warranty is void if tool is disassembled before warranty expires.

A complete Tune-Up Kit, (P/N 96107), is available which includes assorted parts to maintain and repair motor. A Motor Repair Kit (P/N 96046) is available which contains special tools for disassembly/assembly of machine.

Gearbox Disassembly:

1. Disconnect tool from power source.
2. Invert machine and secure in vice, using 57092 Collar (Supplied in 96046 Repair Kit) or padded jaw.
3. Disconnect sanding pad by removing 95885 Screws (2) with a 3mm Hex Key.
4. Remove gearbox assembly by removing 95642 Screws (2) and 95641 Hex Nuts with a phillips head screw driver.
5. Carefully separate 57427 Slider Housing halves. Remove one gearbox half, making sure no parts fall to the ground.
6. Remove and set aside the 57433 Slide-Board on non-vacuum models (57432 on vacuum models), 57431 Transfer Pinion (2), 57438 Counterweight Assembly, 57445 Needle Bearing and the other 57427 Slider Housing half.
7. Clean grease off old dirty components and inspect for damaged parts.

Motor Disassembly:

1. Insert 56058 Lock Ring Wrench (Supplied in 96046 Repair Kit) into corresponding tabs of lock ring and unscrew. Pull with a side to side action to remove motor from housing. Remove 57054 Rear Ring, 57055 Front Ring, 95973 Washer, and 57059 Lock Ring. Motor may now be serviced.
2. Remove 54467 Retaining Ring/Planetary Gear Assembly using (2) 50679 26mm wrenches (Supplied in 96046 Repair Kit). Set aside.
Note: See planetary gear disassembly.
3. Remove 57056 Rear Plate By holding 57058 Cylinder with a 2" Bearing Separator and pressing 54470 Rotor Pinion out of 01206 Bearing.
4. Remove 57113 Blade (5), rotor set and 56047 Rotor Key.
5. Disassemble 57437 Front Plate by pressing 54470 Rotor Pinion through front plate. **Note:** One 01139 Bearing will remain on rotor pinion. To remove press pinion through remaining bearing.
6. Press 01206 Rear Bearing from 57056 Bearing Plate.

Planetary Gear Disassembly:

1. Insert 54470 Rotor Pinion into the center of the planetary gear assembly. Install the 56047 Rotor Key into the key way of the rotor pinion, and hold the rotor pinion in a soft jaws vise.
2. Place a 26mm wrench on the flats of the 54467 Retaining Ring and an adjustable 3mm pin spanner wrench into the two empty holes on the 57430 Cam Assembly. Turn counterclockwise to loosen and remove the cam assembly.
3. Remove 95593 Set Screw from Retaining Ring/Planetary Gear Assembly using a 5/64" allen wrench.
4. Remove 54465 Planetary Carrier by pressing out from 01139 Bearing. 02613 Gears (2) and 54475 Shafts (2) can now be removed from planetary carrier.
5. Remove 54468 Ring Gear by tapping retaining ring on a hard surface. Once the ring slides towards the front, it will be necessary to use your fingers to remove it the rest of the way.
Note: If hard to remove, heat may be applied to retaining ring and pliers used to remove gear.
6. Press 01139 Bearing from 54467 Retaining Ring.

Motor Disassembly Complete.

Planetary Gear Assembly:

Important: Be certain all parts are cleaned, properly greased and in good repair before assembling.

1. Press 01139 Bearing into 54467 Retaining Ring.
2. Place 54468 Ring Gear into 54467 Retaining Ring lining up one of the notches with set screw hole.
3. Hand tighten 95593 Set Screw in place using 5/64" hex key.
4. Install lightly greased Planetary Carrier. Place 54475 Shafts into gears.
5. Slide entire Planetary Carrier Assembly into 54467 Retaining Ring (1/4"-28 female thread facing down).
6. Insert 54470 Rotor Pinion into the center of the planetary gear assembly. Install 56047 Rotor Key into the key way of the rotor pinion.
7. Apply 1 drop of #271 Loctite® (or equivalent) to the threads of 57430 Cam Assembly.
8. Place a 26mm wrench on the flats of the 54467 Retaining Ring and an adjustable 3mm pin spanner wrench into the two empty holes on the 57430 Cam Assembly. Turn clockwise to install the cam assembly.

Motor Assembly:

1. Press 01139 Bearing onto Rotor Pinion until seated against shoulder as shown in Drawing 1.
2. Press assembly into 57437 Front Bearing Plate as shown in Drawing 2 and check for smooth rotation.
3. Place 07146 Packing in front plate bore and press 01139 Bearing into bore onto packing as shown in Drawing 3.
4. Invert rotor pinion in support. Install 56047 Rotor Key and 57113 Blade and Rotor Set onto rotor pinion.
Note: Blades should be lightly lubricated with Dynabrade Air Lube P/N 95842 (or equivalent) before installation.
5. Place 57058 Cylinder Assembly over rotor. The "short" line-up pin goes toward the front plate.
6. Place 57056 Rear Plate (with 01206 Bearing pressed into place) over shaft and "long" end of line-up pin. Press fit in place as shown in Drawing 4.

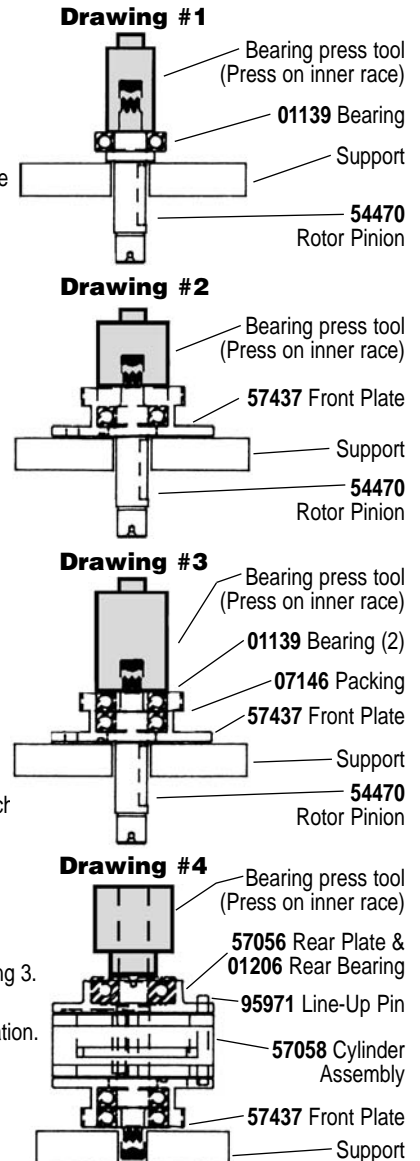

(continued on next page)

Disassembly/Assembly Instructions – Dynabrade Sander (continued)

- Place **57054** Rear Ring over the rear plate and line-up pin. Turn the motor over and place **57055** Front Ring over the front plate making sure the “legs and fingers” on the front and rear rings line-up.
Note: The small cut-outs on both rings should line-up with the square holes in the cylinder/end plate assembly.
- Place **95973** Washer and **57059** Lock Ring onto the front ring with one drop of pneumatic tool oil spread between the washer and the lock ring.
- Secure motor housing in vice, using **57092** Collar or padded jaws. Spread 2-3 drops of pneumatic tool oil around the housing bore for ease of insertion of motor assembly. Slide motor assembly into secured housing.
Note: Be certain line-up pin enters the pocket in the bottom of the housing and the “legs” of the rings stay in-line.
- Tighten lock ring with **56058** Lock Ring Tool to 28 N•m/250 in. - lbs.

Gearbox Assembly:

- Place **57428** Sliders in gearbox halves.
- Install **57429** Felt Seals into gear housing halves. Using Dynabrade’s **95542** Gear Grease (or equivalent), grease entire slider including, transfer pinion holes and groves.
- Grease slide board gear pack and bearing pocket. Grease **57445** Bearing. Place bearing on **57430** Cam Assembly. Grease counterweight gear packs.
- Place counterweight over **57430** Cam Assembly with tool inverted and exhaust at six o'clock. Place cam assembly bearing at three o'clock. Take one gear box half and slide it onto the housing groves.
- Place transfer pinion on counter weight gear rack, sliding pinion shaft partially into mated hole on slider. Repeat for second shaft.
Important: Make sure counter weight is positioned dead center of cam assembly when transfer pinions are installed. This ensures correct timing.
- Making sure needle bearing is still located at three o'clock, place slide board railing into groove on slider while aligning needle bearing into bearing channel on slider board.
- Place other gearbox half onto grooves of motor housing, making sure all parts align. Press both gear box halves together.
- Install **95842** Screws and **95841** Nuts and tighten. Install Pad.

Valve And Speed Regulator Disassembly/Assembly:

- Secure housing in vice using **57092** Collar or padded jaw.
- Remove inlet bushing, **01468** Spring, **01472** Tip Valve, and **01464** Seal from housing.
- Remove **95697** Snap Ring. Press the **57064** Speed Regulator and **01447** Valve Stem out of the housing. Remove the **01025** O-Rings (2).
- Place new **01025** O-Rings (2) on the speed regulator and place in housing with valve stem. Install new **95967** Snap Ring.
- Place **01464** Seal in housing so the pocket of seal sets horizontal and towards the top of the tool. Using a pair of tweezers or needle nose pliers, place the tip valve in the housing so that its pin goes into the valve stem hole and the hinge seats into the pocket of the seal. Place **01468** Spring into the housing small end first.
- Spread one drop of # 271 Loctite® (or equivalent) around the first threads of the inlet bushing and tighten into housing to 23 N•m/200 in. - lbs.

Tool Assembly Complete. Please allow 30 minutes for adhesives to cure before operating tool.

Important: Motor should now be tested for proper operation at 90 PSIG. If motor does not operate properly or operates at a higher RPM than marked on the tool, the tool should be serviced to correct the cause before use. Before operating, place 2-3 drops of Dynabrade Air Lube (P/N **95842**) directly into air inlet with throttle lever depressed. Operate tool for 30 seconds to determine if tool is operating properly and to allow lubricating oils to properly penetrate motor.

Loctite® is a registered trademark of Loctite Corp.

Notice:

All Dynabrade motors use the highest quality parts and metals available and are machined to exacting tolerances. The failure of quality pneumatic motors can most often be traced to an unclean air supply or the lack of lubrication. Air pressure easily forces dirt or water contained in the air supply into motor bearings causing early failure. It often scores the cylinder walls and the rotor blades resulting in limited efficiency and power. Our warranty obligation is contingent upon proper use of our tools and cannot apply to equipment which has been subjected to misuse such as unclean air, wet air or a lack of lubrication during the use of this tool.

Note: To order replacement parts specify the model and serial number of your machine.

Model Number	Motor hp (W)	Motor RPM	Sound Level	Maximum Air Flow SCFM (LPM)	Air Pressure PSIG (Bars)	Weight Pound (kg)	Length Inch (mm)	Height Inch (mm)
All Models	.3 (186)	N/A	84-85 dB(A)	18 (510)	90 (6.2)	2.6 (1.2)	7 (178)	3-3/4 (95)

Additional Specifications: Air Inlet Thread 1/4" NPT • Hose Size 1/4" or 6mm

Optional Accessories



Grease and Grease Gun

- Multi-purpose grease for all types of bearing, cams, gears.
- High film strength; excellent resistance to water, steam, etc.
- Workable range 0°F to 300°F.

95541: Push-type grease gun.

95542: 10oz. (283.5g) tube.



96107 Motor Tune-Up Kit:

- Includes assorted parts to help maintain and repair motor.



Models:

- 57400 - Non-Vac**
- 57401 - Vac-Ready**
- 57402 - Basic Vac**
- 57403 - Deluxe Vac**
- 57404 - Central Vac-Ready**
- 57405 - Versatility Kit**
- 57407 - Non-Vac, w/clips**

Dynaline Sander

*For Serial Number 513366 and Higher
 Palm-Style, Air Powered, 2,400 SPM*

⚠ WARNING

Always operate, inspect and maintain this tool in accordance with the Safety Code for portable air tools (ANSI B186.1) and any other applicable safety codes and regulations. Please refer to Dynabrade's Warning/Safety Operating Instructions for more complete safety information.

Index Key

No.	Part #	Description
1	57429	Felt Seal (4)
2	95885	Screw (2)
3	01211	Lock Washer (2)
4	Slide Board	
	57433	Non-Vacuum
	57432	Vacuum
5	57431	Transfer Pinion (2)
6	57427	Slider Housing Assembly (Incl. 57429 Felt Seal)
7	95641	Nut (2)
8	95642	Screw (2)
9	57434	Vac Adapter (Vac Only)
10	57445	Needle Bearing
11	57430	Cam Assembly
12*	96027	Screw (4)
13*	57439	Rail (2)
14*	57438	Counter Weight
15	01139	Bearing (3)
16	95593	Set Screw
17	54467	Retaining Ring
18	54468	Ring Gear
19	54465	Planetary Carrier
20	06213	Gears (2)
21	54475	Shaft (2)
22	07146	Packing
23	57059	Lock Ring
24	95973	Washer
25	57055	Front Ring
26	57437	Front Bearing Plate
27	56047	Rotor Key
28	54470	Rotor Pinion
29	95975	Shim Pack
30	54491	Rotor/Blade Set
31	57058	Cylinder Assembly (Incl. 95971 Line-Up Pin)
32	95971	Line-Up Pin
33	57056	Rear Bearing Plate
34	01206	Bearing
35	57054	Rear Ring
36	95979	Pin
37	57441	Lever
38	95697	Retaining Ring
39	01025	O-Ring (2)
40	01477	Valve Stem
41	57064	Speed Regulator or Recessed Speed Reg.
42	01464	Seal
43	01472	Tip Valve
44	01468	Spring
45	01494	Inlet Bushing

Symbol	Description
O	Oil: O ₁ = Air Lube
A	Adhesive: A ₂ = Loctite #271 A ₈ = Loctite #567
T	Torque: N•m x 8.85 = In. - lbs.
G	Grease: G ₁ = Lubriplate 630AA

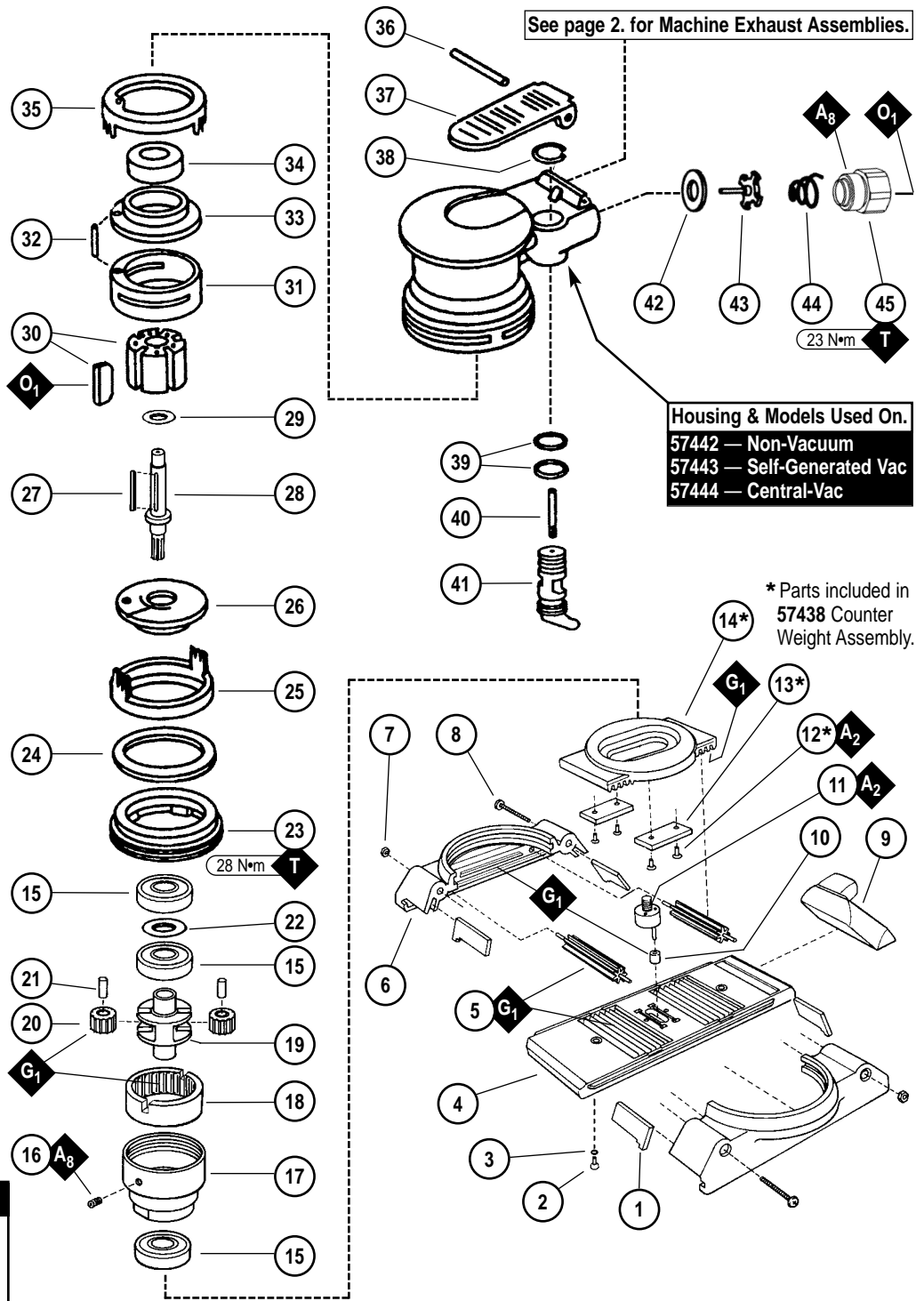

Note: To order replacement parts specify the model and serial number of your machine.

Machine Exhaust Assemblies

Non-Vacuum/Machine Exhaust

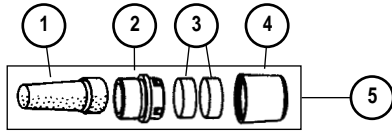

Self Generated Vacuum (Vac-Ready) / Machine Exhaust

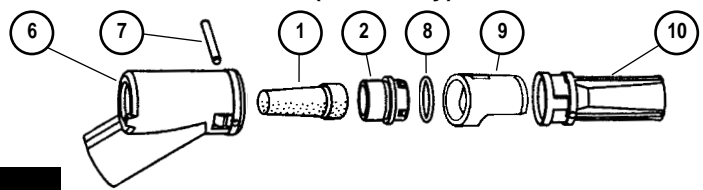

Central Vacuum/Machine Exhaust

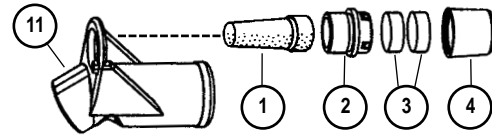

Index Key

No.	Part #	Description	No.	Part #	Description
1	57065	Cone Plug	7	96197	Dowel Pin
2	57066	Muffer Cap	8	95526	O-Ring
3	56027	Muffer Insert (2)	9	57446	Vac Nozzle
4	56028	Muffer Cap	10	57067	Vac Tube
5	57124	Muffer Assembly	11	57093	Vacuum Adapter
6	57083	Vacuum Adapter			

Important Operating, Maintenance and Safety Instructions

Carefully read all instructions before operating or servicing any Dynabrade® Abrasive Power Tool.

Warning: Hand, wrist and arm injury may result from repetitive work motion and overexposure to vibration.

Important: All Dynabrade rotary vane air tools must be used with a Filter-Regulator-Lubricator to maintain all warranties.

Operating Instructions:

Warning: Eye, face, respiratory, sound and body protection must be worn while operating power tools. Failure to do so may result in serious injury or death. Follow safety procedures posted in workplace.

1. With power source disconnected from tool, securely fasten abrasive/accessory on tool.
2. Connect power source to tool. Be careful **not** to depress throttle lever in the process.
3. Check tool speed with tachometer. If tool is operating at a higher speed than the SPM marked on the tool or operating improperly, the tool should be serviced to correct the cause before use.

Maintenance Instructions:

Products offered by Dynabrade should not be converted or otherwise altered from original design without expressed written consent from Dynabrade, Inc.

1. All Dynabrade rotary vane air motors should be lubricated. Dynabrade recommends one drop of air lube per minute for each 10 SCFM (example: if the tool specifications state 40 SCFM, set the drip rate of your filter-lubricator at 4 drops per minute). Dynabrade Air Lube (P/N 95842: 1 pt. 473 ml.) is recommended.
2. Mineral spirits are recommended when cleaning tool. Do not clean tool with any solvents or oils containing concentrated acids, esters, ketones chlorinated hydrocarbons or nitro hydrocarbons.
3. An Air Line Filter-Regulator-Lubricator must be used with this air tool to maintain all warranties. Dynabrade recommends the following: **11405** Air Line Filter-Regulator-Lubricator — Provides accurate air pressure regulation, two-stage filtration of water contaminants and micro-mist lubrication of pneumatic components. Operates 40 SCFM @ 100 PSIG has 3/8" NPT female ports.
4. Frequent drainage of water traps in air lines is recommended.
5. Some silencers on air tools may clog with use. Clean and replace as required.
6. A Motor Tune-Up Kit (P/N 96107) is available which includes assorted parts to help maintain and repair motor.

Safety Instructions:

- **Warning:** Eye, face, respiratory, sound and body protection must be worn while operating power tools. Failure to do so may result in serious injury or death. Follow safety procedures posted in workplace.
- **Important:** User of tool is responsible for following accepted safety codes such as those published by the American National Standards Institute (ANSI).
- Tool SPM must never exceed abrasive/sanding pad SPM rating, regardless of tool capacity.
- Operate machine for 30 seconds before application to workpiece to determine if machine is safely performing before work begins.
- Always disconnect power supply before changing abrasive or making machine adjustments.
- Inspect abrasives and sanding pads for damage or defects prior to and during operation of tool.
- Please refer to Dynabrade's Warning/Safety Operating Instructions Tag (Reorder No. 95903) for more complete safety information.
- **Warning:** Hand, wrist and arm injury may result from repetitive work, motion and overexposure to vibration.

One Year Warranty:

Following the reasonable assumption that any inherent defect which might prevail in a product will become apparent to the user within one year from the date of purchase, all equipment of our manufacture is warranted against defects in workmanship and materials under normal use and service. We shall repair or replace at our factory, any equipment or part thereof which shall, within one year after delivery to the original purchaser, indicate upon our examination to have been defective. Our obligation is contingent upon proper use of Dynabrade tools in accordance with factory recommendations, instructions and safety practices. It shall not apply to equipment which has been subject to misuse, negligence, accident or tampering in any way so as to affect its normal performance. Normally wearable parts such as bearings, contact wheels, rotor blades, etc., are not covered under this warranty.

Disassembly/Assembly Instructions – Dynaline Sander

Important: Manufacturer's warranty is void if tool is disassembled before warranty expires.

A complete Tune-Up Kit, (P/N 96107), is available which includes assorted parts to maintain and repair motor. A Motor Repair Kit (P/N 96046) is available which contains special tools for disassembly/assembly of machine.

Gearbox Disassembly:

1. Disconnect tool from power source.
2. Invert machine and secure in vice, using **57092** Collar (Supplied in **96046** Repair Kit) or padded jaw.
3. Disconnect sanding pad by removing **95885** Screws (2) with a 3mm Hex Key.
4. Remove gearbox assembly by removing **95642** Screws (2) and **95641** Hex Nuts with a phillips head screw driver.
5. Carefully separate **57427** Slider Housing halves. Remove one gearbox half, making sure no parts fall to the ground.
6. Remove and set aside the **57433** Slide-Board on non-vacuum models (**57432** on vacuum models), **57431** Transfer Pinion (2), **57438** Counterweight Assembly, **57445** Needle Bearing and the other **57427** Slider Housing half.
7. Clean grease off old dirty components and inspect for damaged parts.

Motor Disassembly:

1. Insert **56058** Lock Ring Wrench (Supplied in **96046** Repair Kit) into corresponding tabs of lock ring and unscrew. Pull with a side to side action to remove motor from housing. Remove **57054** Rear Ring, **57055** Front Ring, **95973** Washer, and **57059** Lock Ring. Motor may now be serviced.
2. Remove **54467** Retaining Ring/Planetary Gear Assembly using (2) **50679** 26mm wrenches (Supplied in **96046** Repair Kit). Set aside.
Note: See planetary gear disassembly.
3. Remove **57056** Rear Plate By holding **57058** Cylinder with a 2" Bearing Separator and pressing **54470** Rotor Pinion out of **01206** Bearing.
4. Remove **54491** Blade (5), rotor set and **56047** Rotor Key.
5. Disassemble **57437** Front Plate by pressing **54470** Rotor Pinion through front plate. **Note:** One **01139** Bearing will remain on rotor pinion. To remove press pinion through remaining bearing.
6. Press **01206** Rear Bearing from **57056** Bearing Plate.

Planetary Gear Disassembly:

1. Insert **54470** Rotor Pinion into the center of the planetary gear assembly. Install the **56047** Rotor Key into the key way of the rotor pinion, and hold the rotor pinion in a soft jaws vise.
2. Place a 26mm wrench on the flats of the **54467** Retaining Ring and an adjustable 3mm pin spanner wrench into the two empty holes on the **57430** Cam Assembly. Turn counterclockwise to loosen and remove the cam assembly.
3. Remove **95593** Set Screw from Retaining Ring/Planetary Gear Assembly using a 5/64" allen wrench.
4. Remove **54465** Planetary Carrier by pressing out from **01139** Bearing. **02613** Gears (2) and **54475** Shafts (2) can now be removed from planetary carrier.
5. Remove **54468** Ring Gear by tapping retaining ring on a hard surface. Once the ring slides towards the front, it will be necessary to use your fingers to remove it the rest of the way.
Note: If hard to remove, heat may be applied to retaining ring and pliers used to remove gear.
6. Press **01139** Bearing from **54467** Retaining Ring.

Motor Disassembly Complete.

Planetary Gear Assembly:

Important: Be certain all parts are cleaned, properly greased and in good repair before assembling.

1. Press **01139** Bearing into **54467** Retaining Ring.
2. Place **54468** Ring Gear into **54467** Retaining Ring lining up one of the notches with set screw hole.
3. Hand tighten **95593** Set Screw in place using 5/64" hex key.
4. Install lightly greased Planetary Carrier. Place **54475** Shafts into gears.
5. Slide entire Planetary Carrier Assembly into **54467** Retaining Ring (1/4"-28 female thread facing down).
6. Insert **54470** Rotor Pinion into the center of the planetary gear assembly. Install **56047** Rotor Key into the key way of the rotor pinion.
7. Apply 1 drop of #271 Loctite® (or equivalent) to the threads of **57430** Cam Assembly.
8. Place a 26mm wrench on the flats of the **54467** Retaining Ring and an adjustable 3mm pin spanner wrench into the two empty holes on the **57430** Cam Assembly. Turn clockwise to install the cam assembly.

Motor Assembly:

1. Press **01139** Bearing onto Rotor Pinion until seated against shoulder as shown in Drawing 1.
2. Press assembly into **57437** Front Bearing Plate as shown in Drawing 2 and check for smooth rotation.
3. Place **07146** Packing in front plate bore and press **01139** Bearing into bore onto packing as shown in Drawing 3
4. Invert rotor pinion in support. Install **56047** Rotor Key and **54491** Blade and Rotor Set onto rotor pinion. Use as many shims as needed to achieve a 0.001" gap between the rotor and the front bearing plate.
Note: Blades should be lightly lubricated with Dynabrade Air Lube P/N **95842** (or equivalent) before installation
5. Place **57058** Cylinder Assembly over rotor. The "short" line-up pin goes toward the front plate.
6. Place **57056** Rear Plate (with **01206** Bearing pressed into place) over shaft and "long" end of line-up pin. Press fit in place as shown in Drawing 4.

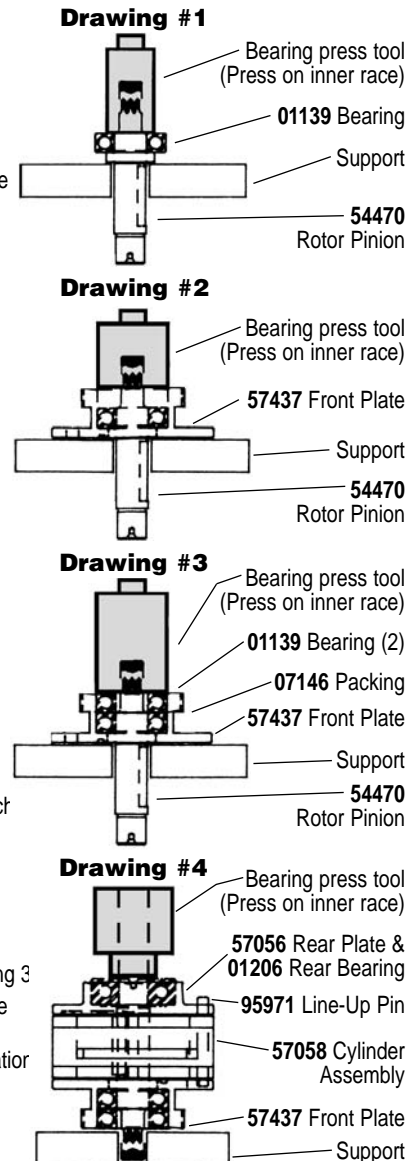

(continued on next page)

Disassembly/Assembly Instructions – Dynabrade Sander (continued)

- Place **57054** Rear Ring over the rear plate and line-up pin. Turn the motor over and place **57055** Front Ring over the front plate making sure the “legs and fingers” on the front and rear rings line-up.
Note: The small cut-outs on both rings should line-up with the square holes in the cylinder/end plate assembly.
- Place **95973** Washer and **57059** Lock Ring onto the front ring with one drop of pneumatic tool oil spread between the washer and the lock ring.
- Secure motor housing in vice, using **57092** Collar or padded jaws. Spread 2-3 drops of pneumatic tool oil around the housing bore for ease of insertion of motor assembly. Slide motor assembly into secured housing.
Note: Be certain line-up pin enters the pocket in the bottom of the housing and the “legs” of the rings stay in-line.
- Tighten lock ring with **56058** Lock Ring Tool to 28 N•m/250 in. - lbs.

Gearbox Assembly:

- Place **57428** Sliders in gearbox halves.
- Install **57429** Felt Seals into gear housing halves. Using Dynabrade’s **95542** Gear Grease (or equivalent), grease entire slider including, transfer pinion holes and groves.
- Grease slide board gear pack and bearing pocket. Grease **57445** Bearing. Place bearing on **57430** Cam Assembly. Grease counterweight gear packs.
- Place counterweight over **57430** Cam Assembly with tool inverted and exhaust at six o'clock. Place cam assembly bearing at three o'clock. Take one gear box half and slide it onto the housing groves.
- Place transfer pinion on counter weight gear rack, sliding pinion shaft partially into mated hole on slider. Repeat for second shaft.
Important: Make sure counter weight is positioned dead center of cam assembly when transfer pinions are installed. This ensures correct timing.
- Making sure needle bearing is still located at three o'clock, place slide board railing into groove on slider while aligning needle bearing into bearing channel on slider board.
- Place other gearbox half onto grooves of motor housing, making sure all parts align. Press both gear box halves together.
- Install **95842** Screws and **95841** Nuts and tighten. Install Pad.

Valve And Speed Regulator Disassembly/Assembly:

- Secure housing in vice using **57092** Collar or padded jaw.
- Remove inlet bushing, **01468** Spring, **01472** Tip Valve, and **01464** Seal from housing.
- Remove **95697** Snap Ring. Press the **57064** Speed Regulator and **01447** Valve Stem out of the housing. Remove the **01025** O-Rings (2).
- Place new **01025** O-Rings (2) on the speed regulator and place in housing with valve stem. Install new **95967** Snap Ring.
- Place **01464** Seal in housing so the pocket of seal sets horizontal and towards the top of the tool. Using a pair of tweezers or needle nose pliers, place the tip valve in the housing so that its pin goes into the valve stem hole and the hinge seats into the pocket of the seal. Place **01468** Spring into the housing small end first.
- Spread one drop of # 271 Loctite® (or equivalent) around the first threads of the inlet bushing and tighten into housing to 23 N•m/200 in. - lbs.

Tool Assembly Complete. Please allow 30 minutes for adhesives to cure before operating tool.

Important: Motor should now be tested for proper operation at 90 PSIG. If motor does not operate properly or operates at a higher RPM than marked on the tool, the tool should be serviced to correct the cause before use. Before operating, place 2-3 drops of Dynabrade Air Lube (P/N **95842**) directly into air inlet with throttle lever depressed. Operate tool for 30 seconds to determine if tool is operating properly and to allow lubricating oils to properly penetrate motor.

Loctite® is a registered trademark of Loctite Corp.

Notice:

All Dynabrade motors use the highest quality parts and metals available and are machined to exacting tolerances. The failure of quality pneumatic motors can most often be traced to an unclean air supply or the lack of lubrication. Air pressure easily forces dirt or water contained in the air supply into motor bearings causing early failure. It often scores the cylinder walls and the rotor blades resulting in limited efficiency and power. Our warranty obligation is contingent upon proper use of our tools and cannot apply to equipment which has been subjected to misuse such as unclean air, wet air or a lack of lubrication during the use of this tool.

Note: To order replacement parts specify the model and serial number of your machine.

Model Number	Motor hp (W)	Motor RPM	Sound Level	Maximum Air Flow CFM/SCFM (LPM)	Air Pressure PSIG (Bars)	Weight Pound (kg)	Length Inch (mm)	Height Inch (mm)
All Models	.3 (186)	N/A	84-85 dB(A)	3/18 (510)	90 (6.2)	2.6 (1.2)	7 (178)	3-3/4 (95)

Additional Specifications: Air Inlet Thread 1/4" NPT • Hose Size 1/4" or 8mm

Optional Accessories



Grease and Grease Gun

- Multi-purpose grease for all types of bearing, cams, gears.
- High film strength; excellent resistance to water, steam, etc.
- Workable range 0°F to 300°F.

95541: Push-type grease gun.

95542: 10oz. (283.5g) tube.



96107 Motor Tune-Up Kit:

- Includes assorted parts to help maintain and repair motor.



Models:
 57400 - Non-Vac
 57401 - Vac-Ready
 57402 - Basic Vac
 57403 - Deluxe Vac
 57404 - Central Vac-Ready
 57407 - Non-Vac, w/clips

KEY

O Oil	G Grease
L Loctite/Hernon: L ₂ = Loctite #271	
T Torque: N•m x 8.85 = In. - lbs. T ₂ = 23 N•m, T ₃ = 28 N•m	

Dynaline Sander

**For Serial Number 513366 and Higher
 Air-Powered, Finishing Sander; 2400 SPM**

WARNING

Always operate, inspect and maintain this tool in accordance with the Safety Code for portable air tools (ANSI B186.1) and any other applicable safety codes and regulations. Please refer to Dynabrade's Warning/Safety Operating Instructions for more complete safety information.

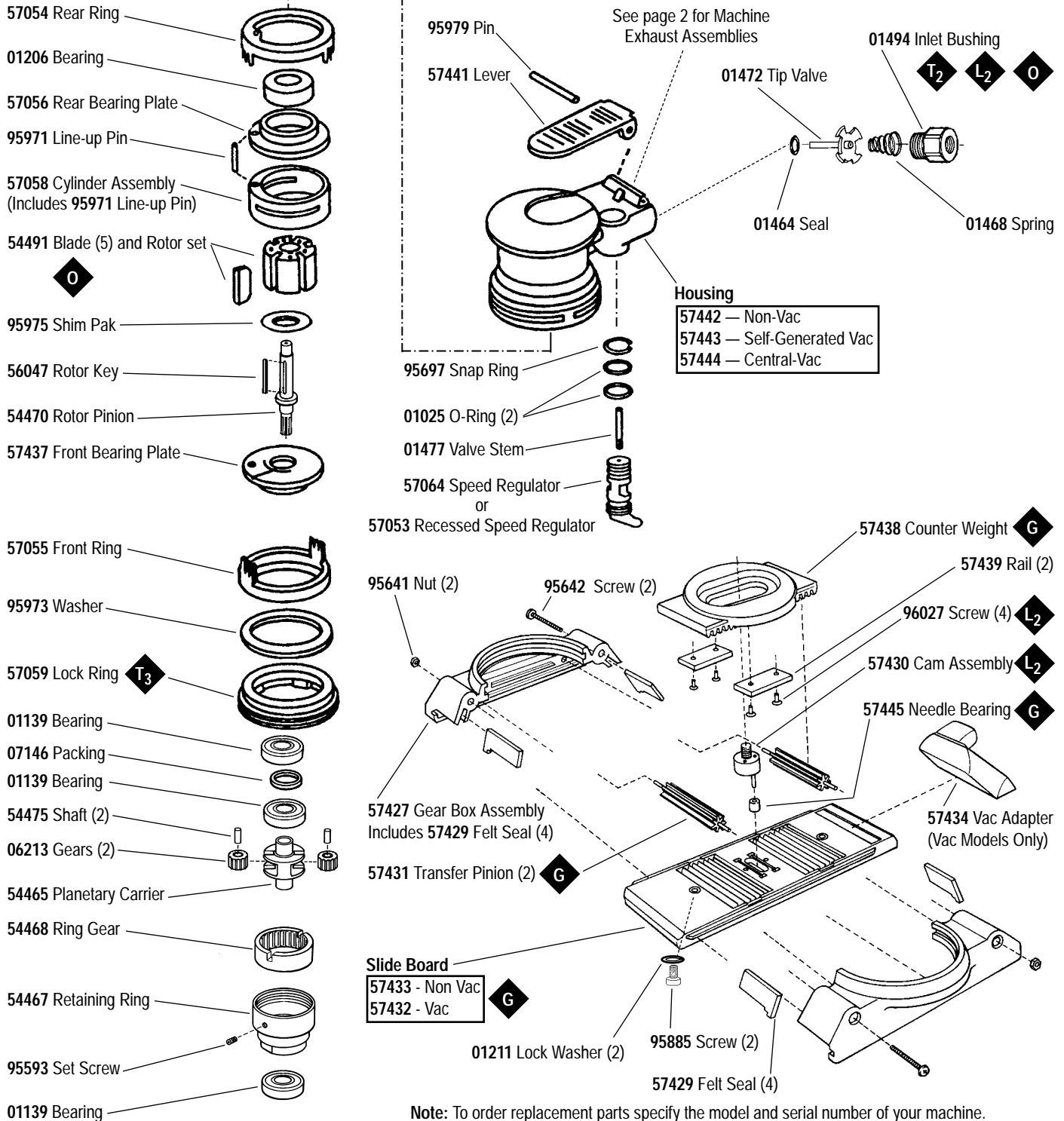

Note: To order replacement parts specify the model and serial number of your machine.

Machine Exhaust Assemblies

Self Generated Vacuum (Vac-Ready) / Machine Exhaust

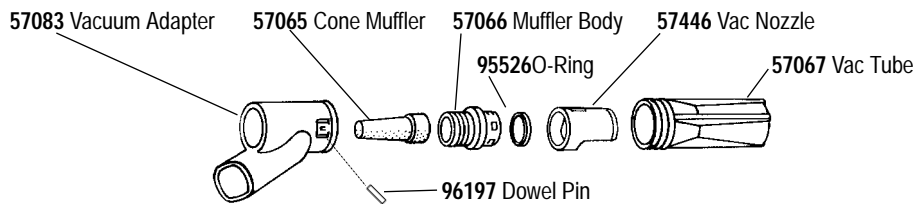

Central Vacuum / Machine Exhaust

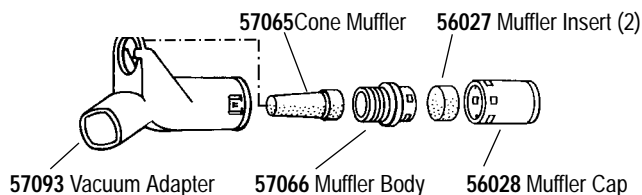

Non-Vacuum / Machine Exhaust

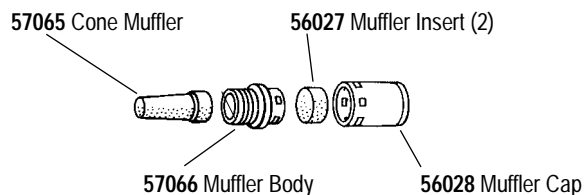

Important Operating, Maintenance and Safety Instructions

Carefully read all instructions before operating or servicing any Dynabrade® Abrasive Power Tool.

Warning: Hand, wrist and arm injury may result from repetitive work motion and overexposure to vibration.

Important: All Dynabrade air tools must be used with a Filter-Regulator-Lubricator to maintain all warranties.

Operating Instructions:

Warning: Eye, face and body protection must be worn while operating power tools. Failure to do so may result in serious injury or death. Follow safety procedures posted in workplace.

1. With power source disconnected from tool, securely fasten abrasive/accessory on tool.
2. Connect power source to tool. Be careful **not** to depress throttle lever in the process.
3. Check tool speed with tachometer. If tool is operating at a higher speed than the SPM marked on the tool or operating improperly, the tool should be serviced to correct the cause before use.

Maintenance Instructions:

Products offered by Dynabrade should not be converted or otherwise altered from original design without expressed written consent from Dynabrade, Inc.

1. All Dynabrade air motors should be lubricated. Dynabrade recommends one drop of air lube per minute for each 10 SCFM (example : if the tool specification state 40 SCFM, set the drip rate of your filter-lubricator at 4 drops per minute). Dynabrade Air Lube (P/N **95842**: 1pt. 473ml.) is recommended.
2. Mineral spirits are recommended when cleaning tool. Do not clean tool with any solvents or oils containing concentrated acids, esters, ketones, chlorinated hydrocarbons or nitro hydrocarbons.
3. An air line filter-regulator-lubricator must be used with this air tool to maintain all warranties. Dynabrade recommends the following: **11289** Air Line Filter-Regulator-Lubricator— Provides accurate air pressure regulation, two-stage filtration of water contaminants and micro-mist lubrication of pneumatic components. Operates 28 CFM @ 90 PSI has 3/8" NPT female ports.
4. Frequent drainage of water traps in air lines is recommended.
5. Some silencers on air tools may clog with use. Clean and replace as required.
6. A motor tune-up kit (P/N **96107**) is available which includes assorted parts to help maintain motor in tip-top shape.

Safety Instructions:

- **Warning:** Eye, face and body protection must be worn while operating power tools. Failure to do so may result in serious injury or death Follow safety procedures posted in workplace.
- **Important:** User of tool is responsible for following accepted safety codes such as those published by the American National Standards Institute (ANSI).
- Tool SPM must never exceed abrasive/sanding pad SPM rating, regardless of tool capacity.
- Operate machine for 30 seconds before application to workpiece to determine if machine is safely performing before work begins.
- Always disconnect power supply before changing abrasive or making machine adjustments.
- Inspect abrasives and sanding pads for damage or defects prior to and during operation of tool.
- Please refer to Dynabrade's Warning/Safety Operating Instructions Tag (Reorder No. 95903) for more complete safety information.
- **Warning:** Hand, wrist and arm injury may result from repetitive work, motion and overexposure to vibration.

One Year Warranty:

Following the reasonable assumption that any inherent defect which might prevail in a product will become apparent to the user within one year from the date of purchase, all equipment of our manufacture is warranted against defects in workmanship and materials under normal use and service. We shall repair or replace at our factory, any equipment or part thereof which shall, within one year after delivery to the original purchaser, indicate upon our examination to have been defective. Our obligation is contingent upon proper use of Dynabrade tools in accordance with factory recommendations, instructions and safety practices. It shall not apply to equipment which has been subject to misuse, negligence, accident or tampering in any way so as to affect its normal performance. Normally wearable parts such as bearings, contact wheels, rotor blades, etc., are not covered under this warranty.

Disassembly/Assembly Instructions – Dynaline Sander

Important: Manufacturers warranty is void if tool is disassembled before warranty expires.

A complete tune-up kit , (P/N 96107), is available which includes assorted parts to maintain motor in tip-top shape. A motor repair kit (P/N 96046) is available which contains special tools for disassembly/assembly of machine.

Gearbox Disassembly:

1. Disconnect tool from power source.
2. Invert machine and secure in vice, using 57092 Collar (Supplied in 96046 Repair Kit) or padded jaw.
3. Disconnect sanding pad by removing 95885 Screws (2) with a 2.5 mm wrench.
4. Remove gearbox assembly by removing 95642 Screws (2) and 95641 Hex Nuts with a phillips head screw driver.
5. Carefully separate 57427 Gearbox Halves. Remove one Gearbox half, making sure no parts fall to the ground.
6. Remove and set aside the 57433 Slide-Board on non-vacuum models (57432 on vacuum models), 57431 Transfer Pinion (2), 57438 Counterweight Assembly, 57445 Needle Bearing and the other 57427 Gearbox half.
7. Clean grease off old dirty components and inspect for damaged parts.

Motor Disassembly:

1. Insert 56058 Lock Ring Wrench (Supplied in 96046 Repair Kit) into corresponding tabs of lock ring and unscrew. Pull with a side to side action to remove motor from housing. Remove 57054 Rear Ring, 57055 Front Ring, 95973 washer, and 57059 Lock Ring. Motor may now be serviced.
2. Remove 54467 Retaining Ring/Planetary Gear Assembly using (2) 50679 26 mm wrenches (Supplied in 96046 Repair Kit). Set aside.
Note: See Planetary Gear Disassembly.
3. Remove 57056 Rear Plate By holding onto 57058 Cylinder and pressing 54470 Rotor Pinion out of 01206 Bearing.
4. Remove 54491 Blade (5), rotor set and 56047 Rotor Key.
5. Disassemble 57437 Front Plate by pressing 54470 Rotor Pinion through front plate. **Note:** One 01139 Bearing will remain on rotor pinion. To remove, press pinion through remaining bearing.
6. Press 01206 Rear Bearing from 57056 Bearing Plate.

Planetary Gear Disassembly:

1. Insert 54470 Rotor Pinion into the center of the planetary gear assembly. Install the 56047 Rotor Key into the key way of the rotor pinion, and hold the rotor pinion in a soft jaws vise.
2. Place a 26mm wrench on the flats of the 54467 Retaining Ring and an adjustable 3mm pin spanner wrench into the two empty holes on the 57430 Cam Assembly. Turn counterclockwise to loosen and remove the cam assembly.
3. Remove 95593 Set Screw from Retaining Ring/Planetary Gear Assembly using a 5/64" allen wrench.
4. Remove 54465 Planetary Carrier by pressing out from 01139 Bearing. 02613 Gears (2) and 54475 Shafts (2) can now be removed from planetary carrier.
5. Remove 54468 Ring Gear by tapping retaining ring on a hard surface. Once the ring slides towards the front, it will be necessary to use your fingers to remove it the rest of the way.
Note: If hard to remove, heat may be applied to retaining ring and pliers used to remove gear.
6. Press 01139 Bearing from 54467 Retaining Ring.

Motor disassembly complete.

Planetary Gear Reassembly:

Important: Be certain all parts are cleaned, properly greased and in good repair before reassembly.

1. Press 01139 Bearing into 54467 Retaining Ring.
2. Place 54468 Ring Gear into 54467 Retaining Ring lining up one of the notches with set screw hole.
3. Hand tighten 95593 Set Screw in place using 5/64" hex key.
4. Install lightly greased Planetary Carrier. Place 54475 Shafts into gears.
5. Slide entire Planetary Carrier Assembly into 54467 Retaining Ring (1/4"-28 female thread facing down).
6. Insert 54470 Rotor Pinion into the center of the planetary gear assembly. Install 56047 Rotor Key into the key way of the rotor pinion.
7. Apply 1 drop of #271 Loctite® (or equivalent) to the threads of 57430 Cam Assembly.
8. Place a 26mm wrench on the flats of the 54467 Retaining Ring and an adjustable 3mm pin spanner wrench into the two empty holes on the 57430 Cam Assembly. Turn clockwise to install the cam assembly.

Motor Reassembly:

1. Press 01139 Bearing onto Rotor Pinion until seated against shoulder as shown in Drawing 1.
2. Press assembly into 57437 Front Bearing Plate as shown in Drawing 2 and check for smooth rotation.
3. Place 07146 Packing in front plate bore and press 01139 Bearing into bore onto packing as shown in drawing 3.
4. Invert rotor pinion in support. Install 56047 Rotor Key and 54491 Blade and Rotor Set onto rotor pinion. Use as many shims as needed to achieve a 0.001" gap between the rotor and the front bearing plate.
Note: Blades should be lightly lubricated with Dynabrade Air Lube P/N 95842 (or equivalent) before installation.
5. Place 57058 Cylinder Assembly over rotor. The "short" line-up pin goes toward the front plate.
6. Place 57056 Rear Plate (with 01206 Bearing pressed into place) over shaft and "long" end of line-up pin. Press fit in place as shown in Drawing 4.

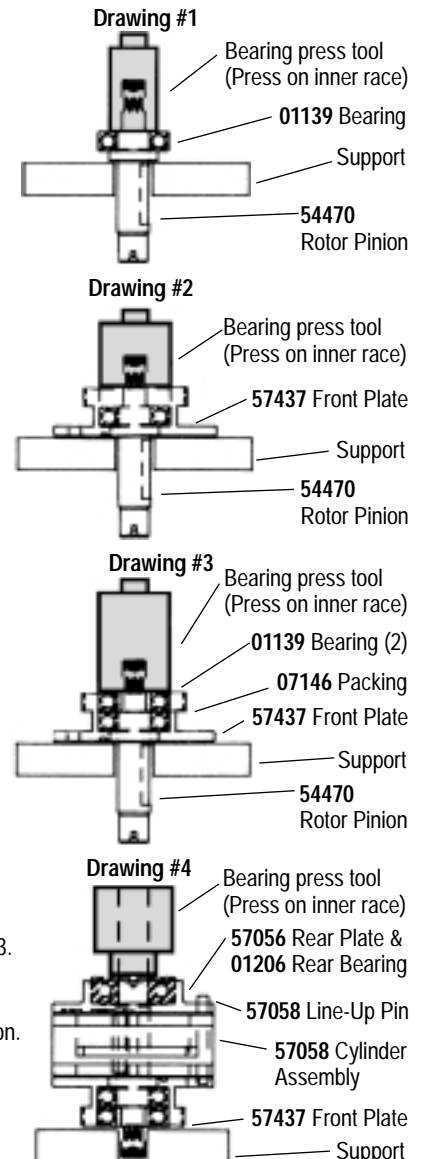

(continued on next page)

Disassembly/Assembly Instructions – Dynabrade Sander (continued)

- Place **57054** Rear Ring over the rear plate and line-up pin. Turn the motor over and place **57055** Front Ring over the front plate making sure the "legs and fingers" on the front and rear rings line-up.
Note: The small cut-outs on both rings should line-up with the square holes in the cylinder/endplate assembly.
- Place **95973** Washer and **57059** Lock Ring onto the front ring with one drop of pneumatic tool oil spread between the washer and the lock ring.
- Secure motor housing in vice, using **57092** Collar or padded jaws. Spread 2-3 drops of pneumatic tool oil around the housing bore for ease of insertion of motor assembly. Slide motor assembly into secured housing.
Note: Be certain line-up pin enters the pocket in the bottom of the housing and the "legs" of the rings stay in-line.
- Tighten lock ring with **56058** Lock Ring Tool to 28 N·m/250 in. - lbs.

Gearbox Reassembly:

- Place **57428** Sliders in gearbox halves.
- Install **57429** Felt Seals into gear housing halves. Using Dynabrade's **95542** Gear Grease (or equivalent), grease entire slider including, transfer pinion holes and grooves.
- Grease slide board gear pack and bearing pocket. Grease **57445** Bearing. Place bearing on **57430** Cam Assembly. Grease counterweight gear packs.
- Place counterweight over **57430** Cam Assembly with tool inverted and exhaust at six o'clock. Place cam assembly bearing at three o'clock. Take one gear box half and slide it onto the housing grooves.
- Place transfer pinion on counter weight gear rack, sliding pinion shaft partially into mated hole on slider. Repeat for second shaft.
Important: Make sure counter weight is positioned dead center of cam assembly when transfer pinions are installed. This ensures correct timing.
- Making sure needle bearing is still located at three o'clock, place slide board railing into groove on slider while aligning needle bearing into bearing channel on slider board.
- Place other gearbox half onto grooves of motor housing, making sure all parts align. Press both gear box halves together.
- Install **95842** Screws and **95841** Nuts and tighten. Reinstall Pad.

Valve And Speed Regulator Disassembly/Assembly:

- Secure housing in vice using **57092** Collar or padded jaw.
- Remove inlet bushing, **01468** Spring, **01472** Tip Valve, and **01464** Seal from housing.
- Remove **95697** Snap Ring. Press the **57064** Speed Regulator and **01447** Valve Stem out of the housing. Remove the **01025** O-Rings (2).
- Place new **01025** O-Rings (2) on the speed regulator and place in housing with valve stem. Install new **95967** Snap Ring.
- Place **01464** Seal in housing so the pocket of seal sets horizontal and towards the top of the tool. Using a pair of tweezers or needle nose pliers, place the tip valve in the housing so that its pin goes into the valve stem hole and the hinge seats into the pocket of the seal. Place **01468** Spring into the housing small end first.
- Spread one drop of # 271 Loctite® (or equivalent) around the first threads of the inlet bushing and tighten into housing to 23 N·m/200 in. - lbs.

Tool Assembly is complete. Please allow 30 minutes for adhesives to cure before operating tool.

Important: Motor should now be tested for proper operation at 90 PSI. If motor does not operate properly or operates at a higher RPM than marked on the tool, the tool should be serviced to correct the cause before use. Before operating, place 2-3 drops of Dynabrade Air Lube (P/N **95842**) directly into air inlet with throttle lever depressed. Operate tool for 30 seconds to determine if tool is operating properly and to allow lubricating oils to properly penetrate motor. Loctite® is a registered trademark of Loctite Corp.

Notice:

All Dynabrade motors use the highest quality parts and metals available and are machined to exacting tolerances. The failure of quality pneumatic motors can most often be traced to an unclean air supply or the lack of lubrication. Air pressure easily forces dirt or water contained in the air supply into motor bearings causing early failure. It often scores the cylinder walls and the rotor blades resulting in limited efficiency and power. Our warranty obligation is contingent upon proper use of our tools and cannot apply to equipment which has been subjected to misuse such as unclean air, wet air or a lack of lubrication during the use of this tool.

Note: To order replacement parts specify the model and serial number of your machine.

Optional Accessories



Grease and Grease Gun

- Multi-purpose grease for all types of bearing, cams, gears.
- High film strength; excellent resistance to water, steam, etc.
- Workable range 0°F to 300°F.

95541: Push-type grease gun

95542: 10oz. (283.5g) tube.



96107 Motor Tune-Up Kit:

- Includes assorted parts to help maintain motor in tip-top shape.

