

# Dynorbital® Supreme



12,000 RPM Air Powered Random Orbital Sander

For Serial No. 12K1000B and Higher

## Air Tool Manual – Safety, Operation and Maintenance

SAVE THIS DOCUMENT, EDUCATE ALL PERSONNEL

### Models:

#### 3/8 Orbit

56870 - 3-1/2" Non-Vacuum  
56873 - 3-1/2" Vac-Ready  
56874 - 3-1/2" Central Vac-Ready  
56880 - 5" Non-Vacuum  
56883 - 5" Vac-Ready  
56884 - 5" Central Vac-Ready  
56890 - 6" Non-Vacuum  
56893 - 6" Vac-Ready  
56894 - 6" Central Vac-Ready

#### 3/16 Orbit

56800 - 3-1/2" Non-Vacuum  
56803 - 3-1/2" Vac-Ready  
56804 - 3-1/2" Central Vac-Ready  
56815 - 5" Non-Vacuum  
56818 - 5" Vac-Ready  
56819 - 5" Central Vac-Ready  
56826 - 6" Non-Vacuum  
56829 - 6" Vac-Ready  
56830 - 6" Central Vac-Ready

#### 3/32 Orbit

56840 - 3-1/2" Non-Vacuum  
56843 - 3-1/2" Vac-Ready  
56844 - 3-1/2" Central Vac-Ready  
56850 - 5" Non-Vacuum  
56853 - 5" Vac-Ready  
56854 - 5" Central Vac-Ready  
56859 - 6" Non-Vacuum  
56862 - 6" Vac-Ready  
56863 - 6" Central Vac-Ready



## ⚠ WARNING

Read and understand this tool manual before operating your air tool. Follow all safety rules for the protection of operating personnel as well as adjacent areas. Always operate, inspect and maintain this tool in accordance with the American National Standards Institute (ANSI) Safety Code for Portable Air Tools – B186.1. For additional safety information, refer to Safety Requirements for the Use, Care and Protection of Abrasive Wheels – ANSI B7.1, Code of Federal Regulation – CFR 29 Part 1910, European Committee for Standards (EN) Hand Held Non-Electric Power Tools – Safety Requirements and applicable State and Local Regulations.

## SAFETY LEGEND



### ⚠ WARNING

Read and understand tool manual before work starts to reduce risk of injury to operator, visitors, and tool.

### ⚠ WARNING

Practice safety requirements. Work alert, have proper attire, and do not operate tools under the influence of alcohol or drugs.



### ⚠ WARNING

Eye protection must be worn at all times, eye protection to conform to ANSI Z87.1.

### ⚠ WARNING

Ear protection to be worn when exposure to sound, exceeds the limits of applicable Federal, State or local statutes, ordinances and/or regulations.



### ⚠ WARNING

Respiratory protection to be used when exposed to contaminants that exceed the applicable threshold limit values required by law.

### ⚠ WARNING

Air line hazard, pressurized supply lines and flexible hoses can cause serious injury. Do not use damaged, frayed or deteriorated air hoses and fittings.



### ⚠ WARNING

Some dust created by sanding, grinding, drilling, and other construction activities contain chemicals known to cause cancer, birth defects or other reproductive harm. Some examples of these chemicals are:

- Lead from lead-based paints
- Crystalline silica from bricks and cement and other masonry products
- Arsenic and chromium from chemically treated lumber

Your risk from these exposures varies, depending on how often you do this type of work. To reduce your exposure to these chemicals: work in a well ventilated area, and work with approved safety equipment, such as those dust masks that are specially designed to filter out microscopic particles.

### SAFETY INSTRUCTIONS

Carefully Read all instructions before operating or servicing any Dynabrade® Abrasive Power Tool.

Products offered by Dynabrade are not to be modified, converted or otherwise altered from the original design without expressed written consent from Dynabrade, Inc.

**Tool Intent:** Dynorbital® Supreme Random Orbital Sander is used for sanding and finishing a variety of materials including wood, metal, plastic, fiberglass, solid surfaces, composites, rubber, glass and stone.

**Do Not Use Tool For Anything Other Than Its Intended Applications.**

**Warning:** This power tool is not intended for use in potentially explosive atmospheres and is not insulated against contact with electrical power.

**Training:** Proper care, maintenance, and storage of your tool will maximize its performance.

- Employer's Responsibility – Provide Dynorbital® Supreme operators with safety instructions and training for safe use of tools and accessories.

#### Accessory Selection:

- Abrasive/accessory RPM (speed) rating MUST be approved for AT LEAST the tool RPM rating.
- Before mounting an accessory, visually inspect for defects. Do not use defective accessories.
- Follow tool specifications before choosing size and type of accessory.
- Only use recommended fittings and air line sizes. Air supply hoses and air hose assemblies must have a minimum working pressure rating of 150 PSIG (10 bars, g) or 150 percent of the maximum pressure produced in the system, whichever is higher. (See Tool Machine Specifications Table.)

## OPERATING INSTRUCTIONS

**Warning:** Always wear eye protection. Operator of tool is responsible for following: accepted eye, face, respiratory, hearing and body protection.

**Caution:** Hand, wrist and arm injury may result from repetitive work, motion and overexposure to vibration.

**Warning:** Be sure that any loose clothing, hair and all jewelry is properly restrained.

- Keep hand and clothing away from moving end of the air tool which has a potential hazard of cutting and severing.
- Install air fitting into inlet bushing of tool. Important: Secure inlet bushing of tool with a wrench before attempting to install the air fitting to avoid damaging valve body housing.

**Warning:** Regularly check free speed (RPM) of random orbital sander. The speed (RPM) is checked with the back-up pad securely fastened without any type of sanding accessory attached to the back-up pad. The air pressure must be set to 90 PSIG with the tool running. Checking the RPM requires either a strobe or magnetic tachometer. This procedure is required after all tool repairs and whenever a tool is issued for use. If tool is operating at a higher speed than the RPM marked on the tool housing, or operating improperly, the tool must be serviced and corrected before use.

**Warning:** Tool RPM must never exceed abrasive/accessory RPM rating. Check accessory manufacturer for details on maximum operating speed or special mounting instructions.

**Warning:** Do not free spin the tool away from the work surface with an abrasive sanding disc attached. The sanding disc may detach from the back-up pad causing injury.

**Warning:** Always start the tool with the sanding abrasive against the work. Stop the air flow to the tool as it is removed from the work.

- With power source connected at the air tool relieve hose of air pressure and disconnect tool from air supply when changing recommended accessories.
- Connect air tool to power source. Be careful NOT to depress throttle lever in the process.

**Do not expose air tool to inlet pressure above 90 PSIG or (6.2 Bars).**

**Caution:** After installing the accessory, before testing or use and/or after reassembling tool, the tool must be started at a reduced speed to check for good balance. Gradually increase tool speed. DO NOT USE if tool vibration is excessive. Correct cause, and retest to insure safe operation.

**Warning:** Use only appropriately sized abrasive sanding discs properly secured and centered to the backing pad provided with the air sander.

- DO NOT USE grinding wheels or cutting-off wheels.
- Make sure that work area is uncluttered, and visitors are at a safe range from the tools and debris.

**Warning:** Potentially explosive atmospheres can be caused by dust and fumes resulting from sanding or grinding. Always use dust extraction or suppression systems which are suitable for the material being processed.

- Proceed with caution in unfamiliar surroundings. Hidden hazards may exist, such as electricity or other utility lines.
- Use only Dynabrade weight-mated pads to maintain low vibration levels.
- Use a vise or clamping device to hold work piece firmly in place.
- Work may generate hazardous dust.
- Always be aware of bystanders in work areas.
- Do not apply excessive force on tool or apply "rough" treatment to it.
- Always work with a firm footing, posture and proper lighting.
- Release the throttle lever in case of an interruption of the energy supply.
- Ensure that sparks and debris resulting from work do not create a hazard such as fire or explosion.
- This tool is rear exhaust. Exhaust may contain lubricants, vane material, bearing grease, and other materials flushed through the tool.

### Speed Regulator Flow Control

**Maximum Flow:** Turn Clockwise.

**Minimum Flow:** Turn Counter-clockwise.

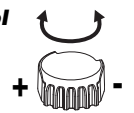

Report to your supervisor any condition of the tool, accessories, or operation you consider unsafe.

## Air System

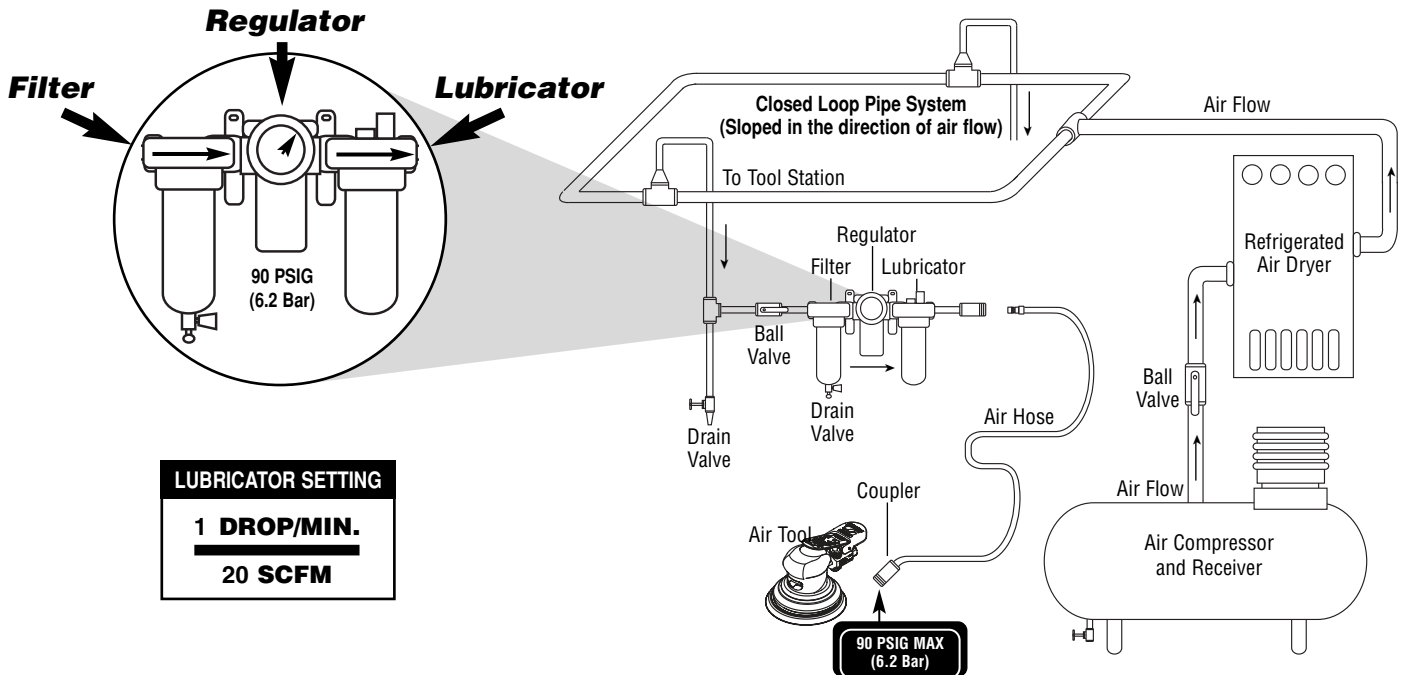

- Dynabrade Air Power Tools are designed to operate at 90 PSIG (6.2 Bar/620 kPa) maximum air pressure at the tool inlet, when the tool is running. Use recommended regulator to control air pressure.

- Ideally the air supply should be free of moisture. To facilitate removing moisture from air supply, the installation of a refrigerated air dryer after the compressor and the use of drain valves at each tool station is recommended.

# Maintenance Instructions

**Important:** To keep tool safe a Preventative Maintenance Program is recommended whenever portable power tools are used.

- Use only genuine Dynabrade replacement parts to ensure quality. To order replacement parts, specify **Model#**, **Serial#** and **RPM** of your air tool.
- It is strongly recommended that all Dynabrade rotary vane air tools be used with a Filter-Regulator-Lubricator to minimize the possibility of misuse due to unclean air, wet air or insufficient lubrication. Dynabrade recommends the following: **10681** Air Filter-Regulator-Lubricator (FRL) – Provides accurate air pressure regulation and two stage filtration of water contaminants.
- Dynabrade recommends one drop of air lube per minute for each 20 SCFM (example: if the tool specification states 40 SCFM, set the drip rate on the filter-lubricator to 2 drops per minute). Dynabrade Air Lube (P/N **95842**: 1 pt 473 ml) is recommended.

**Routine Preventative Maintenance:** Check free speed of Dynorbital® Supreme regularly using a strobe or magnetic tachometer without abrasive accessory attached with 90 PSIG at inlet while tool is running. Always check tool speed after any maintenance or repair. If tool is operating at a higher RPM (speed) than marked on the housing, or operating improperly, the tool must be corrected before use.

- Mineral spirits are recommended when cleaning the tool and parts. Do not clean tool or parts with any solvents or oils containing acids, esters, ketones, chlorinated hydrocarbons or nitro carbons.
- DO NOT clean or maintain tools with chemicals that have a low flash point (example: WD-40®).
- A Tune-Up Kit is available, P/N **96024**.
- Air tool stampings must be kept legible at all times, if not, reorder and replace. User is responsible for maintaining specification information i.e.: Model #, S/N, and RPM.
- Blow air supply hose out prior to initial use.
- Visually inspect air hoses and fittings for frays, visible damage and signs of deterioration. Replace damaged or worn components.
- Refer to Dynabrade's Warning/Safety Operating Instructions Tag (Reorder No. **95903**) for safety information.

After maintenance is performed on tool, add a few drops of Dynabrade Air Lube (P/N **95842**) to the air line and start the tool a few times to lubricate air motor. Check for excessive tool vibration.

## Handling and Storage:

- Protect tool inlet from debris (See Notice Below).
- DO NOT carry tool by air hose.
- Protect abrasive accessories from exposure to water, solvents, high humidity, freezing temperature and extreme temperature changes.
- Store accessories in protective racks or compartments to prevent damage.

## Notice

All Dynabrade motors use the highest quality parts and materials available and are machined to exacting tolerances. The failure of quality pneumatic motors can most often be traced to an unclean air supply or the lack of lubrication. Air pressure easily forces dirt or water contained in the air supply into motor bearings causing early failure. It often scores the cylinder walls and the rotor blades resulting in limited efficiency and power. Our warranty obligation is contingent upon proper use of our tools and cannot apply to equipment which has been subjected to misuse such as unclean air, wet air or a lack of lubrication during the use of this tool.

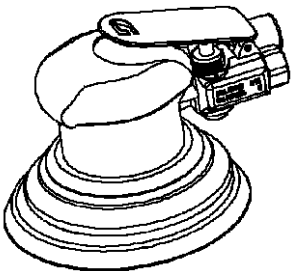



## Self Generated Vacuum

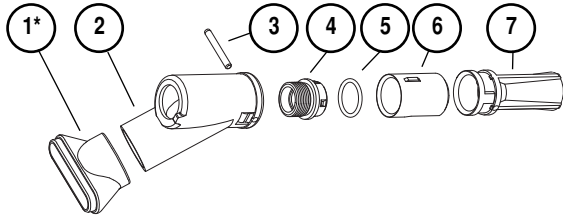

## Central Vacuum

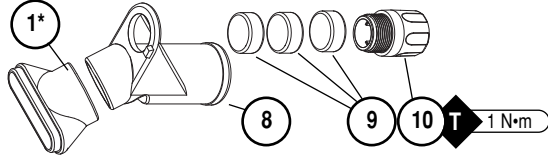

## Non-Vacuum

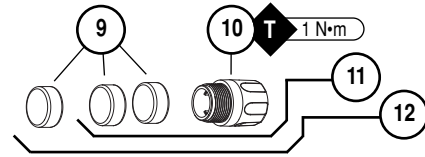

### Index Key

No.	Part #	Description	No.	Part #	Description
1	69364	Shroud Adapter (5" & 6")	7	57067	Vac Tube
2	57083	Vacuum Adapter	8	57093	Central Vacuum Adapter
3	96197	Dowel Pin	9	56027	Muffler Insert (3)
4	57066	Muffler Body	10	69359	Muffler Body
5	95526	O-Ring	11	69272	Muffler Assembly
6	69353	Vac Nozzle	12	69273	Muffler Assembly

Optional: 30 quantity Muffler Insert available, P/N 56054. \* For use on 5" & 6" Diameters Only.

## Motor Assembly/Disassembly Instructions – Dynorbital® Supreme

**Important: Manufacturers warranty is void if tool is disassembled before warranty expires.**

A complete Repair Kit, part number **57098**, is available which includes special tools for correct disassembly/assembly of tool.

### To Disassemble

1. Disconnect tool from power source.
2. Invert machine and secure in vice, using **57092** Collar (supplied in **57098** Repair Kit) or padded jaws.
3. Remove sanding pad with 26 mm open-end wrench (supplied with sander) and shroud or overskirt.
4. Insert **56058** Lock Ring Tool (supplied in **57098** Repair Kit) into corresponding tabs of lock ring and unscrew. Motor may now be lifted out for service.  
**Note:** To get it started try using 26 mm wrench for leverage or rock the motor back and forth to loosen up the rings.
5. Remove lock ring, washer, front ring and rear ring from motor. Upper motor may now be disassembled. Remove **95626** Snap Ring.
6. Remove the rear plate and the cylinder assembly by securing the cylinder in a bearing separator gripped on the cylinder exhaust and extra pocket area. Push the motor shaft balancer through the bearing.
7. Remove the rotor, vanes and rotor key from the motor shaft balancer. Remove the front plate using a small (#2) arbor press. Support the edges of the front plate while pressing on the small end of the motor shaft balancer.
  - a.) If, during step 7, the front plate and **57088** Bearing remain together, press **57088** Bearing out of the front plate using **57091** Press Tool (supplied in **57098** Repair Kit) as shown in **Drawing 1**.
  - b.) If, during step 7, **57088** Bearing remains on the motor shaft balancer, it can be removed with a bearing separator.
9. Remove **01206** Bearing from the rear plate by using a bearing press tool.
10. Disassemble the balancer assembly as follows:
  - a.) Place motor shaft assembly into a soft jaw vise. Using a thin screwdriver, pick out the end of **95630** Snap Ring and peel out. This will loosen the balancer assembly.
  - b.) Screw the threaded portion of the **56056** Bearing Puller (supplied in **57098** Repair Kit) into the **57069** Balancer Shaft and heat the outside of the motor shaft balancer to approximately 200° F (approximately 10 seconds with a propane torch). Now, using the slider weight, pull the assembly out.
  - c.) Press off **56052** Bearing with a bearing separator and remove v-seal.
11. If during step 10, the **56052** Bearing remains in the motor shaft balancer, it can be removed by the heating the shaft balancer again and using either an inside bearing puller or a blind hole bearing puller.

### To Assemble:

**Important:** Be certain parts are clean and in good repair before assembling.

1. Assemble the balancer assembly as follows:
  - a.) Install **95630** Snap Ring onto balancer shaft. Install **59084** V-Seal with the flat side facing up.
  - b.) Apply 1 drop of #271 Loctite® (or equivalent), spread over several places around the inside diameter of the **56052** Bearing and the outside diameter of the **57069** Balancer Shaft.
  - c.) Use the small end of the **57091** Bearing Press Tool and arbor press to install the **56052** Balancer Bearing with the seal side facing the v-seal. **Note:** The inner race of the bearing must sit against the step on the balancer shaft. (Shown in **Drawing 2**.)
2. Place the motor shaft balancer in a soft jaw vise with large end-up.
3. Apply 1 drop of #271 Loctite® (or equivalent) and spread over several places around the outside diameter of the **56052** Bearing and slide balancer assembly into the motor shaft balancer until **56052** Bearing is firmly seated at bottom. Squeeze **95630** Snap Ring into groove in motor shaft balancer to complete the assembly. Remove from vise.
4. Press **57088** Bearing onto the motor shaft balancer down to the shoulder as shown in **Drawing 3**.
5. Press **57057** Front Bearing Plate onto **57088** Bearing as shown in **Drawing 4** and check for smooth rotation.

**Drawing 1**

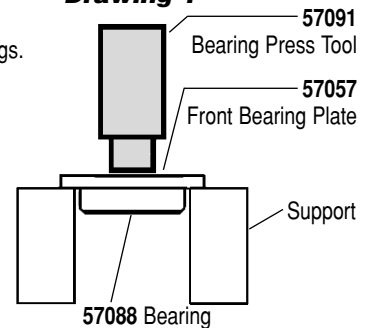

**Drawing 2**

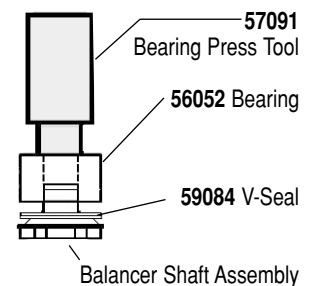

(continued on next page)

# Motor Assembly/Disassembly Instructions – Dynorbital® Supreme (Cont.)

**Drawing 3**

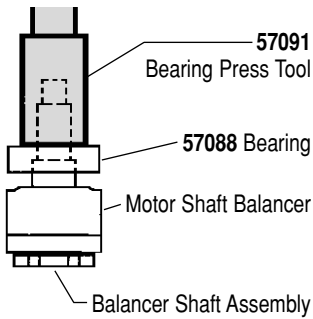

**Drawing 4**

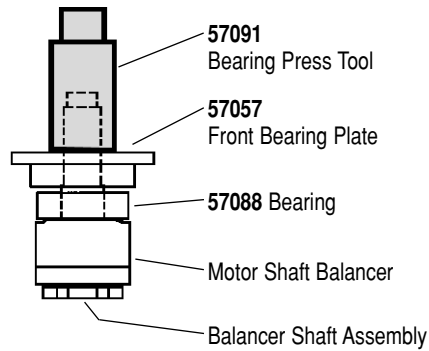

**Drawing 5**

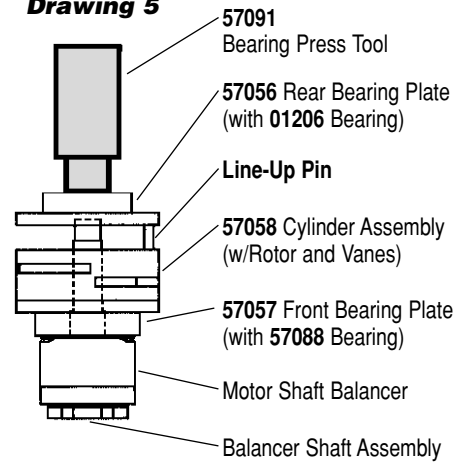

## Special Note: For All 3/8" Orbit Models

The **57059** Lock Ring, **95973** Washer and **57055** Front Ring must be placed over the Motor Shaft Balancer before the **57057** Front Bearing Plate is pressed on.

6. Place the **56047** Rotor Key and rotor on the motor shaft balancer. Place the vanes into the rotor slots. **Note:** Vanes should be lightly lubricated with Dynabrade Air Lube P/N **95842** (or equivalent) before installation.
7. Place **57058** Cylinder Assembly over rotor. The "short" line-up pin goes toward the front plate.
8. Place **57056** Rear Bearing Plate (with **01206** Rear Bearing pressed into place) over shaft and "long" end of line-up pin and press fit in place as shown in **Drawing 5**.
9. Place **95626** Snap Ring in groove.
10. Place **57054** Rear Ring over the rear plate and line-up pin. Turn the motor over and place **57055** Front Ring over the front plate making sure that the "legs and fingers" on the front and rear rings line-up. Also the small cut-outs on both rings should line-up with each other.
11. Place **95973** Washer and **57059** Lock Ring onto the front ring with 1 drop of pneumatic tool oil spread between the washer and lock ring.
12. Secure motor housing in vise, using **57092** Collar or padded jaws. Spread 2-3 drops of pneumatic tool oil around the housing bore for ease of insertion of motor assembly. Slide motor assembly into secured housing. **Note:** Be certain line-up pin enters the pocket in the bottom of the housing and the "legs" of the rings stay in line.
13. Tighten lock ring with **56058** Lock Ring Tool to 28 N•m/250 in. - lbs. Attach shroud or overskirt and weight-mated sanding pad.

**Tool Assembly Complete. Please allow 30 minutes for adhesives to cure before operating tool.**

## Valve and Speed Regulator Assemblies:

1. Secure housing in vice using **57092** Collar or padded jaws.
2. Remove **01494** Inlet Bushing, **01468** Spring, **01472** Tip Valve and **01464** Seal from housing. Remove **94590** Pin from housing, lever and comfort platform.
3. Remove **95697** Snap Ring. Press the speed regulator and valve stem out of the housing. Remove the **01025** O-Rings (2).
4. Place new **01025** O-Rings (2) on the speed regulator and place in housing with valve stem. Install new **95967** Snap Ring.
5. Place new **01464** Seal in housing. Using tweezers or needle nose pliers, place the tip valve into housing so that the pin goes through the valve stem hole. Place new **01468** Spring into housing so small end is towards tip valve.
6. Spread small amount of #567 Loctite® (or equivalent) around the threads of the **01494** Inlet Bushing and tighten into housing to 23 N•m/200 in. - lbs.
7. Install lever and comfort platform on housing with **94590** Pin centered on housing.

**Note:** Motor should operate at between 11,500 and 12,000 RPM at 6.2 bar (90 PSIG). RPM should be checked with a reed tachometer. Before operating, we recommend that 2-3 drops of Dynabrade Air Lube P/N **95842** (or equivalent) be placed directly into the air inlet with throttle lever depressed. Operate the machine for approximately 30 seconds before application to workpiece to determine if machine is working properly and safely and to allow lubricating oils to properly dispense through machine.

Loctite® is a registered trademark of the Loctite Corp.

## Disc Pad Change:

1. Insert **50679** Wrench on flats of **57069** Balancer Shaft and twist off sanding pad by hand.
2. With wrench still in place, hand tighten new pad on tool.
3. No need to remove shroud or overskirt.

## Required Weight of Pads:

- 3-1/2" Models — Use pad weighing 80g.
- 5" Models — Use pad weighing 100g.
- 6" Models — Use pad weighing 130g.

# Preventative Maintenance Schedule

## For All Dynorbital® Supreme Sanders

This service chart is published as a guide to expectant life of component parts. The replacement levels are based on average tool usage over one year. Dynabrade Inc. considers one year usage to be 1,000 hours.

### LEGEND

<b>T</b>	Included in Tune-Up Kit.
<b>X</b>	Type of wear, no other comments apply.
<b>L</b>	Easily lost. Care during assembly/disassembly.
<b>D</b>	Easily damaged during assembly/disassembly.



#### 96024 Tune-Up Kit

- Tune-Up Kit contains high wear and medium wear parts.



#### 57098 Full Service Repair Kit:

Includes special tools for proper disassembly/assembly of the Dynorbital® Supreme.

- Includes:
- 57092 Repair Collar
  - 56058 Lock Ring Wrench
  - 56056 Bearing Puller
  - 57091 Bearing Press Tool
  - 57099 Bearing Puller
  - 96034 12mm Hex Wrench
  - 96066 3/4" Socket

### Parts Common to all Models:

Index #	Part Number	Description	Number Required	High Wear 100%	Medium Wear 70%	Low Wear 30%	Non-Wear 10%
1	See Note	Back-Up Pad	1				X
2	See Note	Lip-Seal Shroud	1			X	
3	See Note	Vacuum Shroud	1				X
4	57069	Balancer Shaft	1				X
5	95630	Snap Ring	1			L	
6	59084	V-Seal	1		T		
7	56052	Bearing	1		T		
8	See Note	Motor Shaft Balancer	1				X
9	56047	Key	1		T		
10	57059	Lock Ring	1			X	
11	95973	Washer	1				X
12	57055	Front Ring	1			X	
13	57088	Bearing	1		T		
14	57057	Front Bearing Plate	1			X	
15	57113	Rotor/Blade Set	1	T			
16	57058	Cylinder	1			X	
17	95971	Line-Up Pin	1		T		
18	57056	Rear Bearing Plate	1			X	
19	01206	Bearing	1		T		
20	57054	Rear Ring	1		T		
21	95626	Snap Ring	1		T		
22	See Note	Housing	1				X
23	See Note	Throttle Lever	1			X	
24	94590	Pin	1		T		
25	57041	Comfort Platform	1			X	
26	95697	Retaining Ring	1		T		
27	01464	Seal	1		T		
28	01472	Tip Valve	1		T		
29	01468	Spring	1		T		
30	01494	Inlet Bushing	1				X
31	01025	O-Ring	2		T		
32	01477	Valve Stem	1		T		
33	57064	Speed Regulator	1			X	
<b>Machine Exhaust Parts</b> (Reference page 5 for your machines specific components.)							
1	69364	Shroud Adapter	1			X	
2	57083	Vacuum Adapter	1			X	
3	96197	Dowel Pin	1			L	
4	57066	Muffler Body	1			X	
5	95526	O-Ring	1		T		
6	69353	Vacuum Nozzle	1			D	
7	57067	Vacuum Tube	1			X	
8	57093	Central Vacuum Adapter	1			X	
9	56027	Muffler Inserts	3	T			
10	69359	Muffler Body	1			X	

**Note:** Please refer to page 4 of tool manual for specific part number.



## Complete Model Description/Housing Number

### 3/8" Orbit Models

Model Number	Vacuum Description	Housing Number
56870	3-1/2" Non-Vacuum	58291
56873	3-1/2" Self Generated Vacuum	58292
56874	3-1/2" Central Vacuum	58293
56880	5" Non-Vacuum	58294
56883	5" Self Generated Vacuum	58295
56884	5" Central Vacuum	58296
56890	6" Non-Vacuum	58297
56893	6" Self Generated Vacuum	58298
56894	6" Central Vacuum	58299

### 3/16" Orbit Models

Model Number	Vacuum Description	Housing Number
56800	3-1/2" Non-Vacuum	57281
56803	3-1/2" Self Generated Vacuum	57282
56804	3-1/2" Central Vacuum	57283
56815	5" Non-Vacuum	57284
56818	5" Self Generated Vacuum	57285
56819	5" Central Vacuum	57286
56826	6" Non-Vacuum	57289
56829	6" Self Generated Vacuum	57290
56830	6" Central Vacuum	57291

### 3/32" Orbit Models

Model Number	Vacuum Description	Housing Number
56840	3-1/2" Non-Vacuum	57693
56843	3-1/2" Self Generated Vacuum	57721
56844	3-1/2" Central Vacuum	57722
56850	5" Non-Vacuum	57690
56853	5" Self Generated Vacuum	57691
56854	5" Central Vacuum	57697
56859	6" Non-Vacuum	57695
56862	6" Self Generated Vacuum	57698
56863	6" Central Vacuum	57696

## Machine Specifications

Model Number	Vacuum Style	Tool Dia. Inch (mm)	Dia. Orbit Inch (mm)	Sound Level	Weight Pound (kg)	Length Inch (mm)
56800	Non-Vac	3-1/2 (89)	3/16 (5)	77 dB(A)	2.1 (1)	6 (152)
56803	Self-Gen	3-1/2 (89)	3/16 (5)	83 dB(A)	2.1 (1)	8-1/4 (210)
56804	Central	3-1/2 (89)	3/16 (5)	79 dB(A)	2.1 (1)	7 (178)
56815	Non-Vac	5 (127)	3/16 (5)	79 dB(A)	2.1 (1)	6-1/2 (165)
56818	Self-Gen	5 (127)	3/16 (5)	81 dB(A)	2.1 (1)	8-1/2 (216)
56819	Central	5 (127)	3/16 (5)	79 dB(A)	2.2 (1)	7-1/4 (184)
56826	Non-Vac	6 (152)	3/16 (5)	77 dB(A)	2.2 (1)	7 (178)
56829	Self-Gen	6 (152)	3/16 (5)	83 dB(A)	2.3 (1)	9 (229)
56830	Central	6 (152)	3/16 (5)	80 dB(A)	2.3 (1)	7-3/4 (197)
56840	Non-Vac	3-1/2 (89)	3/32 (2)	76 dB(A)	2.1 (1)	6 (152)
56843	Self-Gen	3-1/2 (89)	3/32 (2)	81 dB(A)	2.1 (1)	8-1/4 (210)
56844	Central	3-1/2 (89)	3/32 (2)	79 dB(A)	2.1 (1)	7 (178)
56850	Non-Vac	5 (127)	3/32 (2)	76 dB(A)	2.1 (1)	6-1/2 (165)
56853	Self-Gen	5 (127)	3/32 (2)	81 dB(A)	2.1 (1)	8-1/2 (216)

Model Number	Vacuum Style	Tool Dia. Inch (mm)	Dia. Orbit Inch (mm)	Sound Level	Weight Pound (kg)	Length Inch (mm)
56854	Central	5 (127)	3/32 (2)	80 dB(A)	2.2 (1)	7-1/4 (184)
56859	Non-Vac	6 (152)	3/32 (2)	75 dB(A)	2.2 (1)	7 (178)
56862	Self-Gen	6 (152)	3/32 (2)	83 dB(A)	2.3 (1)	9 (229)
56863	Central	6 (152)	3/32 (2)	78 dB(A)	2.3 (1)	7-3/4 (197)
56870	Non-Vac	3-1/2 (89)	3/8 (10)	79 dB(A)	2.2 (1)	6 (152)
56873	Self-Gen	3-1/2 (89)	3/8 (10)	83 dB(A)	2.3 (1)	8-1/4 (210)
56874	Central	3-1/2 (89)	3/8 (10)	80 dB(A)	2.3 (1)	7 (178)
56880	Non-Vac	5 (127)	3/8 (10)	77 dB(A)	2.3 (1)	6-1/2 (165)
56883	Self-Gen	5 (127)	3/8 (10)	83 dB(A)	2.3 (1)	8-1/2 (216)
56884	Central	5 (127)	3/8 (10)	80 dB(A)	2.3 (1)	7-1/4 (184)
56890	Non-Vac	6 (152)	3/8 (10)	79 dB(A)	2.4 (1)	7 (178)
56893	Self-Gen	6 (152)	3/8 (10)	84 dB(A)	2.5 (1.1)	9 (229)
56894	Central	6 (152)	3/8 (10)	83 dB(A)	2.4 (1)	7-3/4 (197)

Additional Specifications: Motor .28 hp (209 W) • Motor 12,000 RPM • Pad Thread 5/16"-24 Male • Air Inlet Thread 1/4" NPT  
 Hose I.D. Size 1/4" (6 mm) • Air Flow Rate 18 SCFM/510 LPM • Height 3-1/2" (89 mm) • Air Pressure 90 PSIG (6.2 Bar)  
 Sound Level is the pressure measurement according to the method outlined in ISO regulation ISO-15744

## Overskirt/Vacuum Conversion Kits

### Non-Vacuum to Vacuum Conversion Kits

Original Non-Vac Tool	Converts to	Kit Part Number
3-1/2" (89mm)	Self-Generated Vac-Ready	57118
3-1/2" (89mm)	Central Vac-Ready	57119
5" (127mm)	Self-Generated Vac-Ready	57120
5" (127mm)	Central Vac-Ready	57121
6" (152mm)	Self-Generated Vac-Ready	57122
6" (152mm)	Central Vac-Ready	57123

### Overskirt Shrouds

Protects pad edges when working near workpiece sides; maximizes dust pick-up on vacuum models.

- 57084:** 3-1/2" Diameter
- 57086:** 5" Diameter
- 57087:** 6" Diameter

