

1 hp Cut-Off Tools

6" Extension, Governor Controlled



Air Tool Manual – Safety, Operation and Maintenance

SAVE THIS DOCUMENT, EDUCATE ALL PERSONNEL

Models:

52576 – 15,000 RPM, 3" Cut-Off

52577 – 18,000 RPM, 3" Cut-Off

52578 – 20,000 RPM, 3" Cut-Off

52579 – 15,000 RPM, 4" Cut-Off

52580 – 18,000 RPM, 4" Cut-Off

52581 – 20,000 RPM, 4" Cut-Off



! WARNING

Read and understand this tool manual before operating your air tool. Follow all safety rules for the protection of operating personnel as well as adjacent areas. Always operate, inspect and maintain this tool in accordance with the American National Safety Institute (ANSI) Safety Code for Portable Air Tools – B186.1. For additional safety information, refer to Safety Requirements for the Use, Care and Protection of Abrasive Wheels – ANSI B7.1, Code of Federal Regulation – CFR 29 Part 1910, European Committee for Standards (EN) Hand Held Non-Electric Power Tools – Safety Requirements and applicable State and Local Regulations.

SAFETY LEGEND

	! WARNING Read and understand tool manual before work starts to reduce risk of injury to operator, visitors, and tool.	
	! WARNING Eye protection must be worn at all times, eye protection to conform to ANSI Z87.1.	
	! WARNING Respiratory protection to be used when exposed to contaminants that exceed the applicable threshold limit values required by law.	
	! WARNING Practice safety requirements. Work alert, have proper attire, and do not operate tools under the influence of alcohol or drugs.	
	! WARNING Ear protection to be worn when exposure to sound, exceeds the limits of applicable Federal, State or local statutes, ordinances and/or regulations.	
	! WARNING Air line hazard, pressurized supply lines and flexible hoses can cause serious injury. Do not use damaged, frayed or deteriorated air hoses and fittings.	

SAFETY INSTRUCTIONS

Carefully Read all instructions before operating or servicing any Dynabrade® Abrasive Power Tool. Products offered by Dynabrade are not to be modified, converted or otherwise altered from the original design without expressed written consent from Dynabrade, Inc.
Tool Intent: Abrasive Cut-Off Tools are ideal for cutting off all types of materials, metals and steel, including stainless and steel alloys.

Do Not Use Tool For Anything Other Than Its Intended Applications.

This power tool is not intended for use in potentially explosive atmospheres and is not insulated against contact with electrical power.

Training: Proper care, maintenance, and storage of your tool will maximize its performance.

- Employer's Responsibility – Provide cut-off tool operators with safety instructions and training for safe use of tools and accessories.

Accessory Selection:

- DO NOT use – non-reinforced cut-off wheels.
- Abrasive/accessory RPM (speed) rating MUST be approved for AT LEAST the tool RPM rating.
- Before mounting an accessory, visually inspect for defects. Do not use defective accessories.
- Mount only recommended accessories. See back page of manual and Dynabrade catalog.
- Follow tool specifications before choosing size and type of accessory
- Only use recommended fittings and air line sizes. Air supply hoses and air hose assemblies must have a minimum working pressure rating of 150 PSIG (10 bars, g) or 150 percent of the maximum pressure in the system, whichever is higher. (See tool Machine Specifications table.)

OPERATING INSTRUCTIONS

Warning: Always wear eye protection. Operator of tool is responsible for following: accepted eye, face, respiratory, hearing and body protection. Always use wheel guard. Make sure it is positioned to best protect the operator and make sure it is fastened. Wheel guards that have been subject to a wheel breaking must be replaced.

OPERATING INSTRUCTIONS (continued)

Caution: Hand, wrist and arm injury may result from repetitive work, motion and overexposure to vibration.

- Keep hand and clothing away from working end of the air tool.

Be sure that any loose clothing, hair and all jewelry is properly restrained.

- Secure inlet bushing on air tool with a wrench before attempting to install the air fitting to avoid damaging housing assembly.
- Check tool RPM (speed) with tachometer with air pressure set at 90 PSIG while the tool is running. If tool is operating at a higher speed than the RPM marked on the tool housing, or operating improperly, the tool must be serviced and corrected before use.

Caution: Tool RPM must never exceed abrasive/accessory RPM rating. Check accessory manufacturer for details on maximum operating speed or special mounting instructions.

- With power source disconnected from air tool, mount cut-off wheel onto spindle. See diagram below for typical mounting assembly.
- Follow recommended procedure from the manufacturer.

CUT-OFF WHEEL MOUNTING

Typical Mounting for Type 1 Cutting-Off Wheels

- Mount reinforced cutting-off wheel 1/8" (3.0mm) **Maximum Thickness**
- Use factory recommended flanges only. Do not substitute.

Caution:

- Air tools are not intended for use in explosive atmospheres and are not insulated for contact with electronic power sources.
- Ensure that sparks and debris resulting from work do not create a hazard.
- This tool is rear exhaust. Exhaust may contain lubricants, vane materials, bearing grease, and other materials flushed thru the tool.
- Warning: Grinding/Sanding certain materials can create explosive dust. It is the employers responsibility

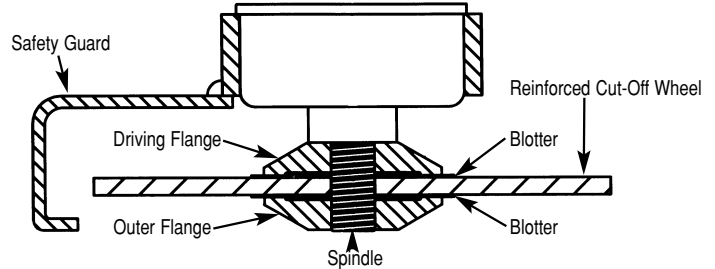

- Connect air tool to power source. Be careful NOT to depress throttle lever in the process. **Do not expose air tool to inlet pressure above 90 PSIG or (6.2 Bars).**

Caution: After installing the accessory, the cut-off tool must be started at a reduced speed to check for good balance. Gradually increase tool speed. DO NOT USE if tool vibration is excessive. Correct cause, and retest to insure safe operation.

- Make sure that work area is uncluttered, and visitors are at a safe range from the tools and debris.
- Use a vise or clamping device to hold work piece firmly in place.
- Do not apply excessive force on tool or apply "rough" treatment to it.
- Always work with a firm footing, posture and proper lighting.

Report to your supervisor any condition of the tool, accessories, or operation you consider unsafe.

Air System

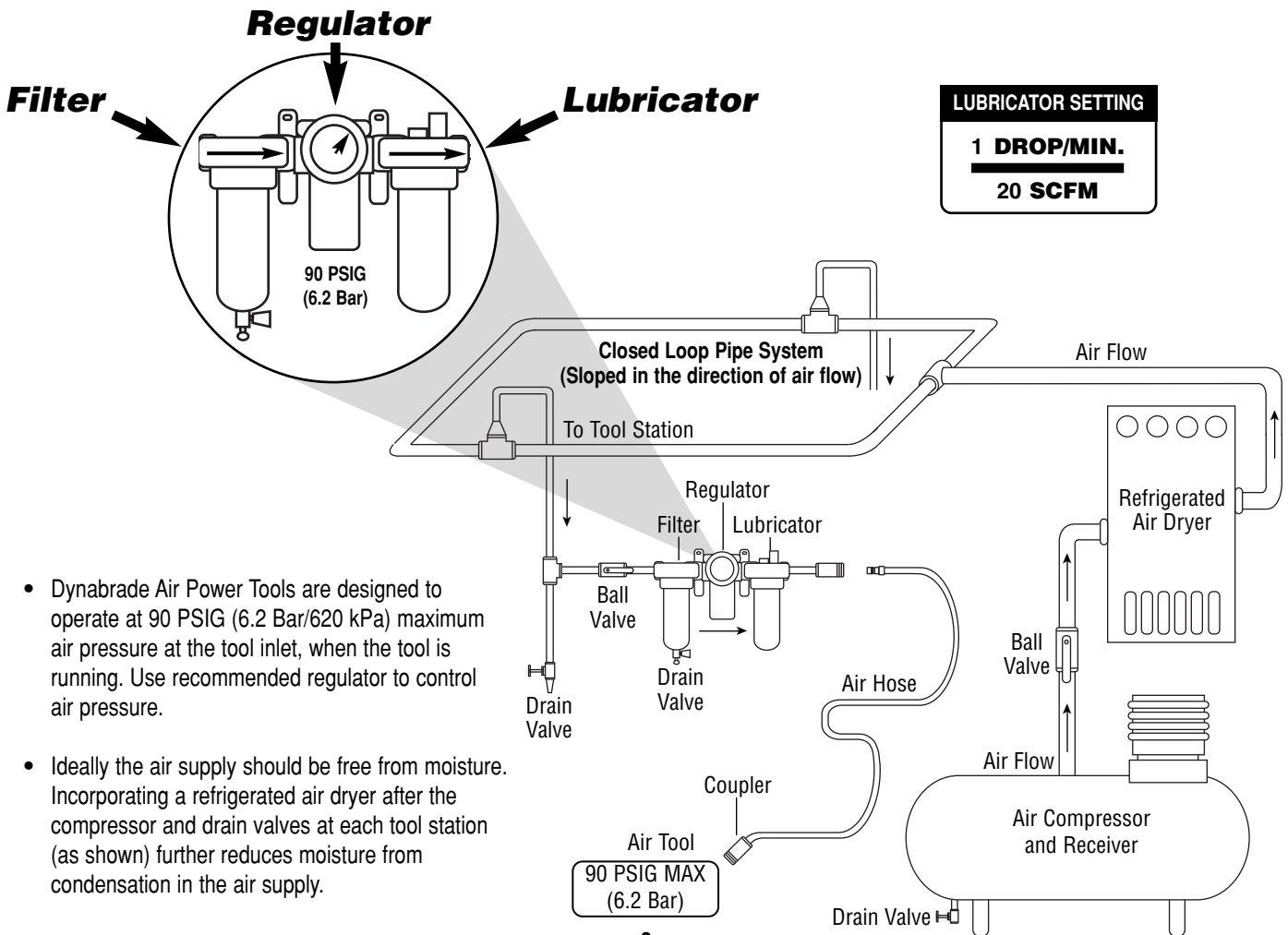

- Dynabrade Air Power Tools are designed to operate at 90 PSIG (6.2 Bar/620 kPa) maximum air pressure at the tool inlet, when the tool is running. Use recommended regulator to control air pressure.
- Ideally the air supply should be free from moisture. Incorporating a refrigerated air dryer after the compressor and drain valves at each tool station (as shown) further reduces moisture from condensation in the air supply.

Maintenance Instructions

Important: A Preventative Maintenance Program is recommended whenever portable power tools are used.

- Use only genuine Dynabrade replacement parts to insure quality. To order replacement parts, specify **Model #**, **Serial #** and **RPM** of your air tool.
- It is strongly recommended that all Dynabrade rotary vane air tools to be used with a Filter-Regulator-Lubricator to minimize the possibility of misuse due to unclean air, wet air or insufficient lubrication. Dynabrade recommends the following: 11405 Air Filter-Regulator-Lubricator (FRL) – Provides accurate air pressure regulation and two stage filtration of water contaminants. Operates 40 SCFM/1,133 LPM 2 100 PSIG with 3/8" NPT female ports.
- Dynabrade recommends one drop of air lube per minute for each 20 SCFM (example: if the tool specification states 40 SCFM, set the drip rate on the filter-lubricator to 2 drops per minute). Dynabrade Air Lube (P/N **95842**: 1 pt 473 ml) is recommended.

Routine Preventative Maintenance: Check free speed of Extension Cut-Off Tools by using a tachometer. This governor controlled extension cut-off wheel should be speed checked every 20 hours of use or weekly, whichever occurs more frequently.

- DO NOT disassemble the governor for any reason. Reorder correct speed – governor assembly (See Assembly Breakdown) and recheck free speed of tool with a tachometer.
- Mineral spirits are recommended when cleaning the tool and parts. Do not clean tool or parts with any solvents or oils containing acids, esters, ketones, chlorinated hydrocarbons or nitro carbons.
- DO NOT clean or maintain tools with chemicals that have a low flash point (example: WD-40®).
- A Motor Tune-Up Kit (P/N **96532**) is available which includes high wear and medium wear motor parts.
- Air tool labels must be kept legible at all times, if not, reorder label(s) and replace. User is responsible for maintaining specification information i.e.: Model #, S/N, and RPM. (See Assembly Breakdown)
- Blow air supply hose out prior to initial use.
- Visually inspect air hoses and fittings for frays, visible damage and signs of deterioration. Replace damaged or worn components.
- Refer to Dynabrade's Warning/Safety Operating Instructions Tag (Reorder No. **95903**) for safety information.

After maintenance is performed on tool, add a few drops of Dynabrade Air Lube (P/N **95842**) to the air line and start the tool a few times to lubricate air motor. Check for excessive tool vibration.

Handling and Storage:

- Use of tool rests, hangers and/or balancers is recommended.
- Protect tool inlet from debris (see Notice below).
- DO NOT carry tool by air hose.
- Protect abrasive accessories from exposure to water, solvents, high humidity, freezing temperature and extreme temperature changes.
- Store accessories in protective racks or compartments to prevent damage.
- DO NOT use cutting-off wheels that show signs of cracks, nicks or other defects.

Machine Specifications

Model Number	Motor HP (W)	Motor RPM	Sound Level	Air Flow Rate CFM/SCFM (LPM)	Air Pressure PSIG (Bars)	Spindle Thread	Weight Pound (kg)	Length Inch (mm)	Height Inch (mm)
52576	1 (744)	15,000	80 dB(A)	5/39 (1104)	90 (6.2)	3/8"-24 male	3.9 (1.8)	15" (381)	3-1/8" (81)
52577	1 (744)	18,000	81 dB(A)	5/40 (1133)	90 (6.2)	3/8"-24 male	3.9 (1.8)	15" (381)	3-1/8" (81)
52578	1 (744)	20,000	80 dB(A)	6/44 (1256)	90 (6.2)	3/8"-24 male	3.9 (1.8)	15" (381)	3-1/8" (81)
52579	1 (744)	15,000	80 dB(A)	5/39 (1104)	90 (6.2)	3/8"-24 male	4 (1.8)	14-7/8" (378)	4-1/2" (113)
52580	1 (744)	18,000	81 dB(A)	6/40 (1133)	90 (6.2)	3/8"-24 male	4 (1.8)	14-7/8" (378)	4-1/2" (113)

Additional Specifications: Air Inlet Thread 3/8" NPT • Hose I.D. Size 3/8" or 10mm • Air Flow Rate Based At Max HP. • Air Pressure 90 PSIG Max

Notice

All Dynabrade motors use the highest quality parts and metals available and are machined to exacting tolerances. The failure of quality pneumatic motors can most often be traced to an unclean air supply or the lack of lubrication. Air pressure easily forces dirt or water contained in the air supply into motor bearings causing early failure. It often scores the cylinder walls and the rotor blades resulting in limited efficiency and power. Our warranty obligation is contingent upon proper use of our tools and cannot apply to equipment which has been subjected to misuse such as unclean air, wet air or a lack of lubrication during the use of this tool.

Disassembly Instructions - 1 Hp Cut-Off Extension Tool

Important: Manufacturer's warranty is void if tool is disassembled before warranty expires.

Disconnect tool from power source before tool repair.

Motor Disassembly:

1. Remove first **50296** Cut-Off Flange and abrasive, then remove the second **50296** Cut-Off Flange.
2. Remove Guard Assembly.
3. Secure housing using **51989** Repair Collar (*see back cover for Optional Accessories*).
4. Apply wrench at wrench flats on **51952** Extension Handle to remove **51952** Extension Handle from housing.
5. Slide **51982** Bearing Spacer and Spindle Assembly through rear of **51952** Extension Handle.
6. Remove **96512** Retaining Ring from front of Extension Handle and remove **51956** Felt Seal.
7. Secure **51955** Spindle at wrench flats, and remove **51950** Spindle Adapter and **51935** Coupler.
8. Secure **01007** Bearing and press **51955** Spindle through both **01007** Bearings.
9. Secure **54520** Bearing and press **51955** Spindle through **54520** Bearing.
10. Remove **96498** Wave Spring.
11. Pull motor assembly, and remove **53620** Motor Adapter with **95438** O-Ring.
12. Remove governor assembly by using a slotted screw driver. (**LEFT HAND** thread)
13. Secure **51925** Cylinder using **96209** Motor Repair Clamp (*order separately*) and place a 1/8" (3mm) drift pin to the base of the internal thread and press the **51921** Rotor from the **02057** Rear Bearing.
14. Slide **02057** Rear Bearing from **51923** Rear Bearing Plate.
15. Remove **51925** Cylinder and **51926** Blades.
16. Secure **51921** Rotor in a padded vise and remove **51935** Extension Coupler (twist counterclockwise).
17. Slide **51922** Front Bearing Plate and **51927** Rotor Spacer from **51921** Rotor.
18. Slide **54520** Bearing and shims from **51922** Front Bearing Plate.

Motor Disassembly Complete.

Housing Disassembly:

1. Secure housing using **51989** Repair Collar (*see back cover for Optional Accessories*).
2. Remove inlet bushing (twist counterclockwise).
3. Remove **53682** Gasket, **51943** Spring, **96442** O-Ring, **51940** Spacer, **94528** Felt Silencer, **53686** Muffler Cap, **94924** Wave Spring and **53683** Spacer from **53681** Inlet Bushing.
4. Remove **51944** Tip Valve and **51945** Valve Seat.
5. Remove housing and **51989** Repair Collar and lay repair collar on bench with flange facing down so the collar is supported by throttle lever. Place a 3/32" (2.4mm) drift pin on **96444** Pin and tap pin thru housing.
6. Remove **51946** Valve Stem Assembly. Remove **96443** O-Ring from **51946** Valve Stem Assembly.

Housing Disassembly Complete.

Assembly Instructions - 1 Hp Cut-Off Extension Tool

Motor Assembly:

Important: Be sure parts are clean and in good repair before assembling. Follow grease, oil and torque specifications.

1. Place **51921** Rotor into padded vise with male thread facing upwards.
2. Slip **51927** Rotor Spacer over rotor shaft and down against rotor body face.
3. Press **96441** Coiled Pin into **51922** Front Bearing Plate. Make certain, coiled pin does not protrude beyond internal bearing surface.
4. Place a .002" shim into the base of **51922** Front Bearing Plate as an initial spacing and slide **54520** Bearing to the front plate base.
Note: **51951** Shim Pack contains .001" and .002" shims.
5. Slip bearing/bearing plate assembly onto rotor. Add one drop of Loctite® #243 (or equiv.) to **51921** Rotor 3/8"-24 male thread, and screw, torque **51935** Extension Coupler onto rotor shaft. Torque to 17 N•m (150 lbs.-in.).
6. Check clearance between rotor and front bearing plate by using a .001" feeler gauge. Clearance should be between .001" – .0015". Adjust clearance by repeating steps 4 and 5 with different shims if necessary.
7. Once proper rotor gap clearance is achieved, install well lubricated **51926** Blades (4) into rotor slots. Dynabrade recommends lubricating blades with **95842** Air Lube.
8. Install **51925** Cylinder over rotor and front plate raised boss. Align coiled pin on front to cylinder slot.
9. Press **96441** Coiled Pin into blind hole on **51923** Rear Bearing Plate. Press (2) **96445** Coiled Pins into the back side of rear bearing plate.
10. Peel backing off **51924** Gasket and align it firmly in place onto **51923** Rear Bearing Plate.
11. Place **51923** Rear Bearing Plate over rotor mandrel and insert raised boss on rear bearing plate into cylinder diameter, while inserting short coiled pin into cylinder slot. Be sure inlet slot on rear bearing plate line up with inlet slot on cylinder. To correct alignment flip cylinder end to end and repeat steps 8 & 9 for correct assembly.

(continued on next page)

Assembly Instructions - (Continued)

Important: Manufacturer's warranty is void if tool is disassembled before warranty expires.

Please refer to parts breakdown for part identification.

12. Using **96243** Bearing Press Tool (*order separately*) press **02057** Bearing onto rotor and onto **51923** Rear Bearing Plate until it is seated.
Important: Cylinder must fit snug between bearing plates. If too tight, rotor will not turn freely. Rotor must be lightly tapped at press fit end until rotor spins freely while still maintaining a snug fit. A loose fit will not achieve the proper preload on motor bearing.
(While pressing 02057 Bearing, make certain to contact inner race of bearing only.)
13. Add one drop of Loctite® 243 (or equiv.) to governor assembly male thread and screw governor assembly onto place (**LEFT HAND** thread) with a slotted screw head. Torque to 2 N•m (18 lb.-in.).
14. Install motor assembly into housing, making sure motor drops all the way into housing. **Note:** Align both **96445** Coiled Pins to slots in insert and against **51924** Gasket.
15. Install **95438** O-Ring onto **53620** Adapter and slide adapter into housing and over **54520** Bearing.
16. Place **96498** Wave Washer onto **53620** Adapter.
17. Place **51936** Coupling Insert into **51935** Coupling. Make certain insert radii aligns with radii in coupling base, to correct alignment remove insert and rotate 90 degrees.
18. Press one **01007** Bearing on end of **51955** Extension Spindle that is further from the wrench flats, then repeat with second **01007** Bearing on same end of spindle. **Important:** While pressing **01007** Bearings, make certain to contact inner race of bearing only.
19. Press **54520** Bearing onto end of spindle that is closer to wrench flats. **Important:** While pressing **54520** Bearing, make certain to contact inner race of bearing only.
20. Secure spindle and apply Loctite® 243 (or equiv.) to external threads then torque **51935** Coupling on single bearing end to 17 N•m (150 lbs. - in.).
21. On double bearing end, apply Loctite® 243 (or equiv.) to external threads and torque **51950** Spindle Adapter to 17 N•m (150 lbs. - in.).
22. Install **51956** Felt Seal over **51950** Spindle Adapter.
23. Install **96512** Retaining Ring into groove inside **51952** Extension Handle.
24. Insert spindle assembly, with spindle adapter first, into larger diameter end of **51952** Extension Handle.
25. Insert **51982** Bearing Spacer into larger diameter end of extension handle.
26. Pull **51936** Coupling Insert half way off of **51935** Coupling.
27. Apply Loctite® 567 (or equiv.) to external threads on housing.
28. Align **51936** Coupling insert onto **51935** Coupling in extension handle.
29. Thread housing assembly onto extension handle.
30. Secure front end of housing in a padded vise, align the vise jaws with machined flat on the silver ring.
31. Apply wrench at wrench flats on **51952** Extension Handle and torque handle onto housing to 28 N•m (250 lbs. - in.).
32. Install guard onto extension housing.
33. Secure **50296** Cut-Off Flange against **51950** Spindle Adapter, slide reinforced cut-off wheel into place and thread second **50296** Cut-Off Flange to secure abrasive wheel. **Caution:** Tighten flange enough to prevent the abrasive wheel from spinning under working conditions. Over tightening can cause damage to the abrasive wheel and/or flanges.

Motor Assembly Complete.

Housing Assembly:

1. Secure housing using **51989** Repair Collar (*see back cover for Optional Accessories*). With coupler facing downward.
2. Install **51945** Valve Seat by aligning 3 male prongs with three deep slots on insert. Make certain valve seat is pressed flat against base of pocket.
Note: Add a few drops of Dynabrade Air Lube (P/N **95842**) to pocket walls before inserting **51945** Valve Seat.
3. Install **51944** Tip Valve as shown.
4. Apply one drop of Loctite® #243 (or equiv.) to **53681** Inlet Bushing thread.
5. Align small inside diameter of **51943** Spring to cone point on **51944** Tip Valve and thread **53681** Inlet Bushing and sub-assembly into place. Torque bushing to 35 N•m (310 lb.-in.).
6. Slide **96443** O-Ring onto **51946** Valve Stem and slide sub-assembly until o-ring passes through housing hole. Make certain valve stem assembly slides freely after the o-ring passes through the hole.
7. Remove housing from **51989** Repair Collar and replace repair collar onto the bench top with the part number identifier against the bench. Align the throttle lever holes to housing pin hole and rest the housing and throttle lever onto the legs of the repair collar. Press **96444** Coiled Pin into lever hole and center into housing.

Tool Assembly Complete. Please allow 30 minutes for adhesives to cure before operating tool.

Important: Before operating, place 2-3 drops of Dynabrade Air Lube (P/N **95842**) directly into inlet with throttle lever depressed. Operate tool for 30 seconds to allow Air Lube to properly lubricate internal motor components. Motor should now be tested for proper operation at 90 PSIG max. If tool operates at a higher RPM than marked on the tool or if vibration and sound levels seem abnormal, the tool should be serviced to correct the cause before use.

Models:

- 52576 - 15,000 RPM, 3" Cut-Off
- 52577 - 18,000 RPM, 3" Cut-Off
- 52578 - 20,000 RPM, 3" Cut-Off

- 52579 - 15,000 RPM, 4" Cut-Off
- 52580 - 18,000 RPM, 4" Cut-Off
- 52581 - 20,000 RPM, 4" Cut-Off

1 hp Cut-Off Tool, 6" Extension Complete Assembly

Index Key

No.	Part #	Description
1	50269	Flange Set (2/pkg.)
2	53633	3" Cut-off Guard
	53634	4" Cut-off Guard
3	51950	Spindle Adapter
4	96512	Retaining Ring
5	51956	Felt Seal
6	01007	Bearing (2)
7	51955	Spindle Extension
8	51952	Handle Extension
9	54520	Bearing
10	51982	Bearing Spacer
11	51969	Coupling Nut (2)
12	50902	Coupler
13	96498	Wave Spring
14	95438	O-Ring
15	53620	Adapter
16	54520	Bearing
17	51951	Shim Pack
18	51922	Front Bearing Plate
19	96441	Pin (2)
20	51927	Spacer
21	51921	Rotor
22	51926	Blade (4/Pkg.)
23	51925	Cylinder
24	51923	Rear Bearing Plate
25	02057	Bearing
26	96445	Pin (2)
27	51924	Gasket
28	Governor Assembly	
	51931	15,000 RPM Models
	51932	18,000 RPM Models
	51933	20,000 RPM Models
29	All Housings Include:	
	Warning & Specification Labels	
	53732	Housing - Model 52576
	53733	Housing - Model 52577
	53734	Housing - Model 52578
	53735	Housing - Model 52579
	53736	Housing - Model 52580
30	96444	Pin
31	51949	Safety Lever Assembly
32	51946	Valve Stem Assembly (Incl. 96443 O-Ring)
33	51945	Valve Seat
34	51944	Tip Valve
35	51943	Spring
36	96442	O-Ring
37	51940	Spacer
38	53682	Gasket
39	94528	Felt Silencer
40	53686	Muffler Cap
41	94924	Wave Spring
42	53683	Spacer
43	53681	Inlet Bushing (Incl. 2 - 51938 Screens)
44	53655	Muffler Assembly
45	53690	Grip

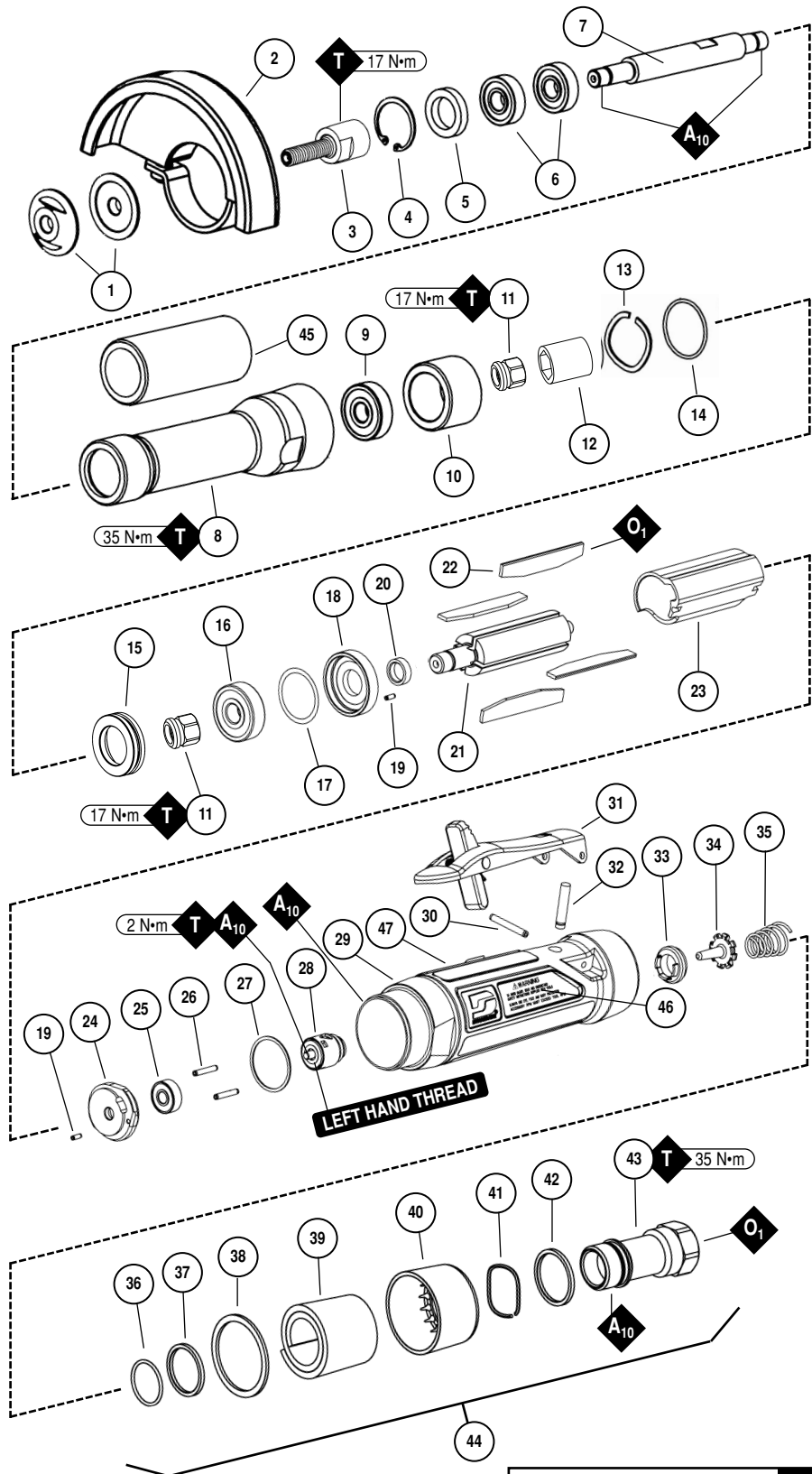

Label Key

No.	Part #	Description
46	00001248	Warning Label
47	00001181	Specification Label

KEY

O Oil: O₁ = Air Lube

A Adhesive: A₁₀ = Loctite #243

T Torque: N·m x 8.85 = In. - lbs.

Always follow adhesive manufacturers cleaning and priming recommendations.

Preventative Maintenance Schedule

For All 1Hp Extension Cut-Off Tools

This service chart is published as a guide to expectant life of component parts. The replacement levels are based on average tool usage over one year. Dynabrade Inc. considers one year usage to be 1,000 hours or 50% of a man year. Parts included in motor tune-up kit are identified by High Wear and Medium Wear items.

Parts Common to all Models:

LEGEND	
T	Part included in 96532 Tune-up Kit
X	Type of wear, no other comments apply.
L	Easily lost. Care during assembly/disassembly.
D	Easily damaged during assembly/disassembly.
R1	Replace each time tool is disassembled.



96532 – 1 Hp Motor Tune-Up Kit

- Tune-Up Kit includes high wear and medium wear motor parts.

Index #	Part Number	Description	Number Required	High Wear 100%	Medium Wear 70%	Low Wear 30%	Non-Wear 10%
1	50269	Flange Set (2/pkg.)	1				X
2	53633	3" Cut-off Guard	1				X
	53634	4" Cut-off Guard	1				X
3	51950	Spindle Adapter	1			X	
4	96512	Retaining Ring	1			X	
5	51956	Felt Seal	1			X	
6	01007	Bearing	2				X
7	51955	Spindle Extension	1				X
8	51952	Handle Extension	1				X
9	54520	Bearing	1			X	
10	51982	Bearing Spacer	1				X
11	51935	Coupling Extension	1				X
12	51936	Coupling Insert	1			X	
13	96498	Wave Spring	1		T, L		
14	95438	O-Ring	1		T, X		
15	53620	Adapter	1				X
16	54520	Bearing	1		T, X		
17	51951	Shim Pack	1		T, X		
18	51922	Front Bearing Plate	1			X	
19	96441	Pin	1			X	
20	51927	Spacer	1		T, X		
21	51921	Rotor	1			X	
22	51926	Blade (4/Pkg.)	1	T, X			
23	51925	Cylinder	1			X	
24	51923	Rear Bearing Plate	1			X	
25	02057	Bearing	1		T, X		
26	96445	Pin	2			X	
27	51924	Gasket	1		T, X		
28	See Note	Governor Assembly	1				X
29	See Note	Housing	1				X
30	96444	Pin	1		T, L		
31	51949	Safety Lever Assembly	1			X	
32	51946	Valve Stem Assembly	1		T, X		
33	51945	Valve Seat	1				X
34	51944	Tip Valve	1		T, X		
35	51943	Spring	1				X
36	96442	O-Ring	1		T, L		
37	51940	Spacer	1				X
38	53682	Gasket	1				X
39	94528	Felt Silencer	1	T, R1			
40	53686	Muffler Cap	1				X
41	94924	Wave Spring	1				X
42	53683	Spacer	1				X
43	53681	Inlet Bushing	1				X
44	53655	Muffler Assembly	1				X
45	53690	Grip	1			X	

Note: Please refer to page 4 of tool manual for specific part number.

Optional Accessories



Dynaswivel®

- Swivels 360° AT TWO PIVOT POINTS allowing the air hose to drop directly to the floor while providing superb tool handling.
- 95461** – 3/8" NPT.

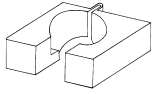

51989 Repair Collar

- Specially designed collar for use in vise to prevent damage to valve body of tool during disassembly/assembly.



Dynabrade Air Lube

- Formulated for pneumatic equipment.
- Absorbs up to 10% of its weight in water.
- Prevents rust and formation of sludge.
- Keeps pneumatic tools operating longer with greater power and less down time.

95842: 1pt. (473 ml)

95843: 1gal. (3.8 L)



96209 Motor Repair Clamp

- Specially designed clamp to secure motor cylinder before disassembly.



96005 Male Plug

- Provides up to twice the air flow compared to standard plug design.
- Plug has "ported" design to prevent "starving" of the air tool.



Bearing Press Tools

- Used to install bearings.

96243: For installing **02057** Bearing.

96244: For installing **01007** & **54520** Bearings.



96532 Motor Tune-Up Kit

- Includes assorted parts to help maintain and repair motor.

01902 Drop-In Motor

- Allows quick and easy replacement. No motor adjustments needed.



53621 Over Hose Assembly

- Over Hose Assembly directs exhaust away from operator.

30335 Air Supply Hose

- 3/8 in. I.D. x 60 in. Wide air supply hose, includes: 3/8 in. NPT male and female threaded fittings.



95262 – 14mm open-end.

95281 – 19mm open-end.