

1hp Right Angle Buffer/Polisher Governor Controlled



Air Tool Manual – Safety, Operation and Maintenance

SAVE THIS DOCUMENT, EDUCATE ALL PERSONNEL

Models:

- 51390 – 1,250 RPM, 5/8"-11
- 51391 – 1,800 RPM, 5/8"-11
- 51392 – 2,800 RPM, 5/8"-11
- 51393 – 4,500 RPM, 5/8"-11
- 51394 – 1,250 RPM, M14 x 2
- 51395 – 1,800 RPM, M14 x 2
- 51396 – 2,800 RPM, M14 x 2
- 51397 – 4,500 RPM, M14 x 2



⚠ WARNING

Read and understand this tool manual before operating your air tool. Follow all safety rules for the protection of operating personnel as well as adjacent areas. Always operate, inspect and maintain this tool in accordance with the American National Standards Institute (ANSI) Safety Code for Portable Air Tools – B186.1. For additional safety information, refer to Safety Requirements for the Use, Care and Protection of Abrasive Wheels – ANSI B7.1, Code of Federal Regulation – CFR 29 Part 1910, European Committee for Standards (EN) Hand Held Non-Electric Power Tools – Safety Requirements and applicable State and Local Regulations.

SAFETY LEGEND

	⚠ WARNING Read and understand tool manual before work starts to reduce risk of injury to operator, visitors, and tool.	⚠ WARNING Practice safety requirements. Work alert, have proper attire, and do not operate tools under the influence of alcohol or drugs.	
	⚠ WARNING Eye protection must be worn at all times, eye protection to conform to ANSI Z87.1.	⚠ WARNING Ear protection to be worn when exposure to sound, exceeds the limits of applicable Federal, State or local statutes, ordinances and/or regulations.	
	⚠ WARNING Respiratory protection to be used when exposed to contaminants that exceed the applicable threshold limit values required by law.	⚠ WARNING Air line hazard, pressurized supply lines and flexible hoses can cause serious injury. Do not use damaged, frayed or deteriorated air hoses and fittings.	

⚠ WARNING

Some dust created by sanding, grinding, drilling, and other construction activities contain chemicals known to cause cancer, birth defects or other reproductive harm. Some examples of these chemicals are:

- Lead from lead-based paints
- Crystalline silica from bricks and cement and other masonry products
- Arsenic and chromium from chemically treated lumber

Your risk from these exposures varies, depending on how often you do this type of work. To reduce your exposure to these chemicals: work in a well ventilated area, and work with approved safety equipment, such as those dust masks that are specially designed to filter out microscopic particles.

SAFETY INSTRUCTIONS

Carefully Read all instructions before operating or servicing any Dynabrade® Abrasive Power Tool.

Products offered by Dynabrade are not to be modified, converted or otherwise altered from the original design without expressed written consent from Dynabrade, Inc.

Tool Intent: Right-Angle Buffer/Polishers are ideal for removal and polishing of materials using deburring, cleaning and polishing accessories.

Do Not use tool for anything other than its intended applications.

This power tool is not intended for use in potentially explosive atmospheres and is not insulated against contact with electrical power.

Training: Proper care, maintenance, and storage of your tool will maximize their performance.

- Employer's Responsibility – Provide right-angle buffer/polisher operators with safety instructions and training for safe use of tools and accessories.

Accessory Selection:

- Abrasive/accessory RPM (speed) rating MUST be approved for AT LEAST the tool RPM rating.
- Before mounting an accessory, visually inspect for defects. Do not use defective accessories.
- Use only recommended accessories. See back page of manual and Dynabrade catalog.
- Follow tool specifications before choosing size and type of accessory.
- Only use recommended fittings and air line sizes. Air supply hoses and air hose assemblies must have a minimum working pressure rating of 150 PSIG (10 Bars, g) or 150 percent of the maximum pressure produced in the system, whichever is higher. (See tool Machine Specifications table.)

OPERATING INSTRUCTIONS

Warning: Always wear eye protection. Operator of tool is responsible for following: accepted eye, face, respiratory, hearing and body protection.

Caution: Hand, wrist and arm injury may result from repetitive work, motion and overexposure to vibration.

- Keep hand and clothing away from working end of the air tool.

Operation: Be sure that any loose clothing, hair and all jewelry is properly restrained.

- Secure inlet bushing on air tool with a wrench before attempting to install the air fitting to avoid damaging housing assembly.
- BEFORE MOUNTING AN ACCESSORY, after all tool repairs and whenever a buffer/polisher is issued for use, check tool RPM (speed) with tachometer with air pressure set at 90 PSIG while the tool is running. If tool is operating at a higher speed than the RPM marked on the tool housing, or operating improperly, the tool must be serviced and corrected before use.

Caution: Tool RPM must never exceed abrasive/accessory RPM rating. Check accessory manufacturer for details on maximum operating speed or special mounting instructions.

- With power source disconnected from air tool, mount recommended accessory.
- Connect air tool to power source. Be careful NOT to depress throttle lever in the process.

Do not expose air tool to inlet pressure above 90 PSIG or (6.2 Bars).

Caution: After installing the accessory, before testing or use and/or after reassembling tool, the right-angle buffer/polisher must be started at a reduced speed to check for good balance. Gradually increase tool speed. DO NOT USE if tool vibration is excessive. Correct cause, and retest to insure safe operation.

- Make sure that work area is uncluttered, and visitors are at a safe range from the tools and debris.
- Air tools are not intended for use in explosive atmospheres and are not insulated for contact with electric power sources.
- Use a vise or clamping device to hold work piece firmly in place.
- Do not apply excessive force on tool or apply "rough" treatment to it.
- Always work with a firm footing, posture and proper lighting.
- Ensure that sparks and debris resulting from work do not create a hazard.
- This tool is rear exhaust. Exhaust may contain lubricants, vane material, bearing grease, and other materials flushed thru the tool.

Report to your supervisor any condition of the tool, accessories, or operation you consider unsafe.

Air System

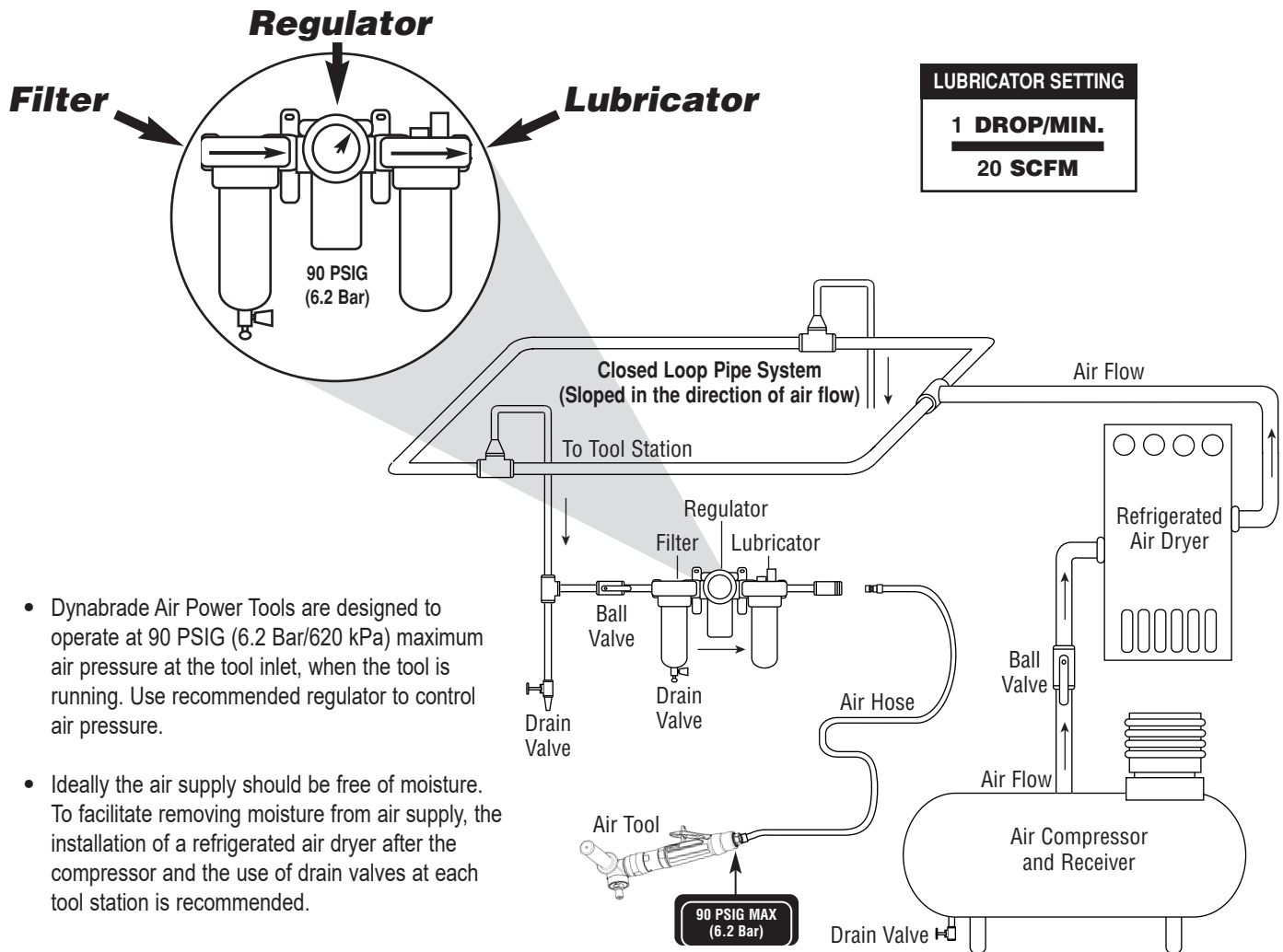

- Dynabrade Air Power Tools are designed to operate at 90 PSIG (6.2 Bar/620 kPa) maximum air pressure at the tool inlet, when the tool is running. Use recommended regulator to control air pressure.
- Ideally the air supply should be free of moisture. To facilitate removing moisture from air supply, the installation of a refrigerated air dryer after the compressor and the use of drain valves at each tool station is recommended.

Maintenance Instructions

Important: To keep tool safe a preventative maintenance program is recommended whenever portable power tools are used. The program should include inspection of air supply lines, air line pressure, proper lubrication and repair of tools. Refer to ANSI B186.1 for additional maintenance information.

- Use only genuine Dynabrade replacement parts to insure quality. To order replacement parts, specify **Model#**, **Serial#** and **RPM** of your air tool.
- It is strongly recommended that all Dynabrade rotary vane air tools be used with a Filter-Regulator-Lubricator to minimize the possibility of misuse due to unclean air, wet air or insufficient lubrication. Dynabrade recommends the following: **10681** Air Filter-Regulator-Lubricator (FRL) – Provides accurate air pressure regulation and two stage filtration of water contaminants.
- Lubricate wick system through the angle gear oil fitting with 2-3 plunges for every 8 hours of use, to achieve maximum gear life. **Important:** Use only the recommended angle gear oil for the wick system. Do not contaminate the wick with any other oil or grease product (order **95848** Gear oil and **95541** Gun).
- Grease the planetary gear assembly with the **95542** Grease by applying **2-3 plunges** with the **95541** Grease Gun after **every 50 hours** of use for maximum gear life.
- Dynabrade recommends one drop of air lube per minute for each 20 SCFM (example: if the tool specification states 40 SCFM, set the drip rate on the filter-lubricator to 2 drops per minute). Dynabrade Air Lube (P/N **95842**: 1 pt 473 ml) is recommended.

Routine Preventative Maintenance:

- Check free speed of right-angle buffer/polisher using a tachometer. This governor controlled right-angle buffer/polisher should be speed checked every 20 hours of use or weekly, whichever occurs more frequently.
- **DO NOT** disassemble the governor for any reason. Reorder correct speed – governor assembly (See Assembly Breakdown) and recheck free speed of tool with a tachometer.
- Mineral spirits are recommended when cleaning the tool and parts. Do not clean tool or parts with any solvents or oils containing acids, esters, ketones, chlorinated hydrocarbons or nitro carbons.
- **DO NOT** clean or maintain tools with chemicals that have a low flash point (example: WD-40®).
- A Motor Tune-Up Kit (P/N **96532**) is available which includes high wear and medium wear motor parts.
- Air tool labels must be kept legible at all times, if not, reorder label(s) and replace. User is responsible for maintaining specification information i.e.: Model #, S/N, and RPM. (See Assembly Breakdown)
- Blow air supply hose out prior to initial use.
- Visually inspect air hoses and fittings for frays, visible damage and signs of deterioration. Replace damaged or worn components.
- Refer to Dynabrade's Warning/Safety Operating Instructions Tag (Reorder No. **95903**) for safety information.

After maintenance is performed on tool, add a few drops of Dynabrade Air Lube (P/N **95842**) to the air line and start the tool a few times to lubricate air motor. Check for excessive tool vibration.

Handling and Storage:

- Use of tool rests, hangers and/or balancers is recommended.
- Protect tool inlet from debris (see Notice below).
- **DO NOT** carry tool by air hose, or near the tool throttle lever.
- Protect abrasive accessories from exposure to water, solvents, high humidity, freezing temperature and extreme temperature changes.
- Store accessories in protective racks or compartments to prevent damage.

Machine Specifications

Model Number	Motor hp (W)	Tool RPM	Sound Level	Air Flow Rate SCFM (LPM)	Air Pressure PSIG (Bars)	Spindle Thread	Weight Pound (kg)	Length Inch (mm)	Height Inch (mm)
51390	1 (746)	1,250	83 dB(A)	42 (1,189)	90 (6.2)	5/8"-11	4.8 (2.2)	13-1/8 (333)	3-3/4 (95)
51391	1 (746)	1,800	82 dB(A)	42 (1,189)	90 (6.2)	5/8"-11	4.8 (2.2)	13-1/8 (333)	3-3/4 (95)
51392	1 (746)	2,800	80 dB(A)	41 (1,161)	90 (6.2)	5/8"-11	4.8 (2.2)	13-1/8 (333)	3-3/4 (95)
51393	1 (746)	4,500	79 dB(A)	35 (991)	90 (6.2)	5/8"-11	4.0 (1.8)	11-11/16 (296)	3-3/4 (95)
51394	1 (746)	1,250	83 dB(A)	42 (1,189)	90 (6.2)	M14 x 2.0	4.8 (2.2)	13-1/8 (333)	3-3/4 (95)
51395	1 (746)	1,800	82 dB(A)	42 (1,189)	90 (6.2)	M14 x 2.0	4.8 (2.2)	13-1/8 (333)	3-3/4 (95)
51396	1 (746)	2,800	80 dB(A)	41 (1,161)	90 (6.2)	M14 x 2.0	4.8 (2.2)	13-1/8 (333)	3-3/4 (95)
51397	1 (746)	4,500	79 dB(A)	35 (991)	90 (6.2)	M14 x 2.0	4.0 (1.8)	11-11/16 (296)	3-3/4 (95)

Additional Specifications: Air Inlet Thread 3/8" NPT • Hose I.D. Size 3/8" (10 mm) • Air Flow Rate Based At Max HP. • Air Pressure 90 PSIG Max

Notice

All Dynabrade motors use the highest quality parts and materials available and are machined to exacting tolerances. The failure of quality pneumatic motors can most often be traced to an unclean air supply or the lack of lubrication. Air pressure easily forces dirt or water contained in the air supply into motor bearings causing early failure. It often scores the cylinder walls and the rotor blades resulting in limited efficiency and power. Our warranty obligation is contingent upon proper use of our tools and cannot apply to equipment which has been subjected to misuse such as unclean air, wet air or a lack of lubrication during the use of this tool.

1hp Right Angle Buffer/Polisher Complete Assembly

Index Key

No.	Part #	Description
1	50963	Retainer
2	50899	Seal
3	53603	Spindle - 5/8"-11
	53606	Spindle - M14 x 2
4	97679	Bearing
5	97678	Shim
6	97677	Shim
7	Gear Set	
	53639	1,250 and 4,500 RPM
	53637	1,800 and 2,800 RPM
8	53608	Wick
9	53600	Right-Angle Housing Assy. Includes the following:
	A	96325 Shell Bearing
	B	53649 Gear Oil Plate
	C	01041 Gear Oil Fitting
10	53163	Side Handle
11	01266	Bearing
12	53635	Pinion Adapter
13	51969	Coupler Nut (2)
14	50902	Coupler
15	53650	Lock Ring
16	53651	Spacer
17	96498	Wave Spring (2 Needed For Slow Speed)
18	95438	O-Ring
19	53620	Adapter
20	54520	Bearing (2 Needed For Slow Speed)
21	04014	Set Screw
22	01041	Grease Fitting
23	53695	Gear Casing
24	53676	Carrier (1,250 - 1,800 RPM)
	53669	Carrier (2,800 RPM)
25	53193	Gear (2) (1,250 - 1,800 RPM)
	53195	Gear (2) (2,800 RPM)
26	04026	Needle Bearing (4)
27	53679	Shaft (2)
28	53665	Ring Gear
29	51951	Shim Pack
30	51922	Front Bearing Plate
31	96441	Pin (2)
32	51927	Spacer
33	53667	Rotor (1,250 - 1,800 RPM)
	53666	Rotor (2,800 RPM)
	51921	Rotor (4,500 RPM)
34	51926	Blade (4/Pkg.)
35	51925	Cylinder
36	51923	Rear Bearing Plate
37	02057	Bearing
38	96445	Pin (2)
39	51924	Gasket
40	Governor Assembly	
	51932	1,250 RPM Models
	51931	1,800 RPM Models
	51933	2,800 RPM Models
	51643	4,500 RPM Models
41	All Housings Include:	
	Warning & Specification Labels	
	20080	Housing - Model 51390
	20081	Housing - Model 51391
	20082	Housing - Model 51392
	20083	Housing - Model 51393
	20084	Housing - Model 51394
	20085	Housing - Model 51395
	20086	Housing - Model 51396
	20087	Housing - Model 51397
42	96444	Pin
43	51949	Safety Lever Assembly
44	51946	Valve Stem Assembly (Incl. 96443 O-Ring)
45	51945	Valve Seat
46	51944	Tip Valve
47	51943	Spring
48*	96442	O-Ring
49*	51940	Spacer
50	53682	Gasket - Standard
	53687	Gasket - For use with overhose
51*	94528	Felt Silencer
52*	53686	Muffler Cap
53*	94924	Wave Spring
54*	53683	Spacer
55*	53681	Inlet Bushing (Incl. 2 - 51938 Screens)

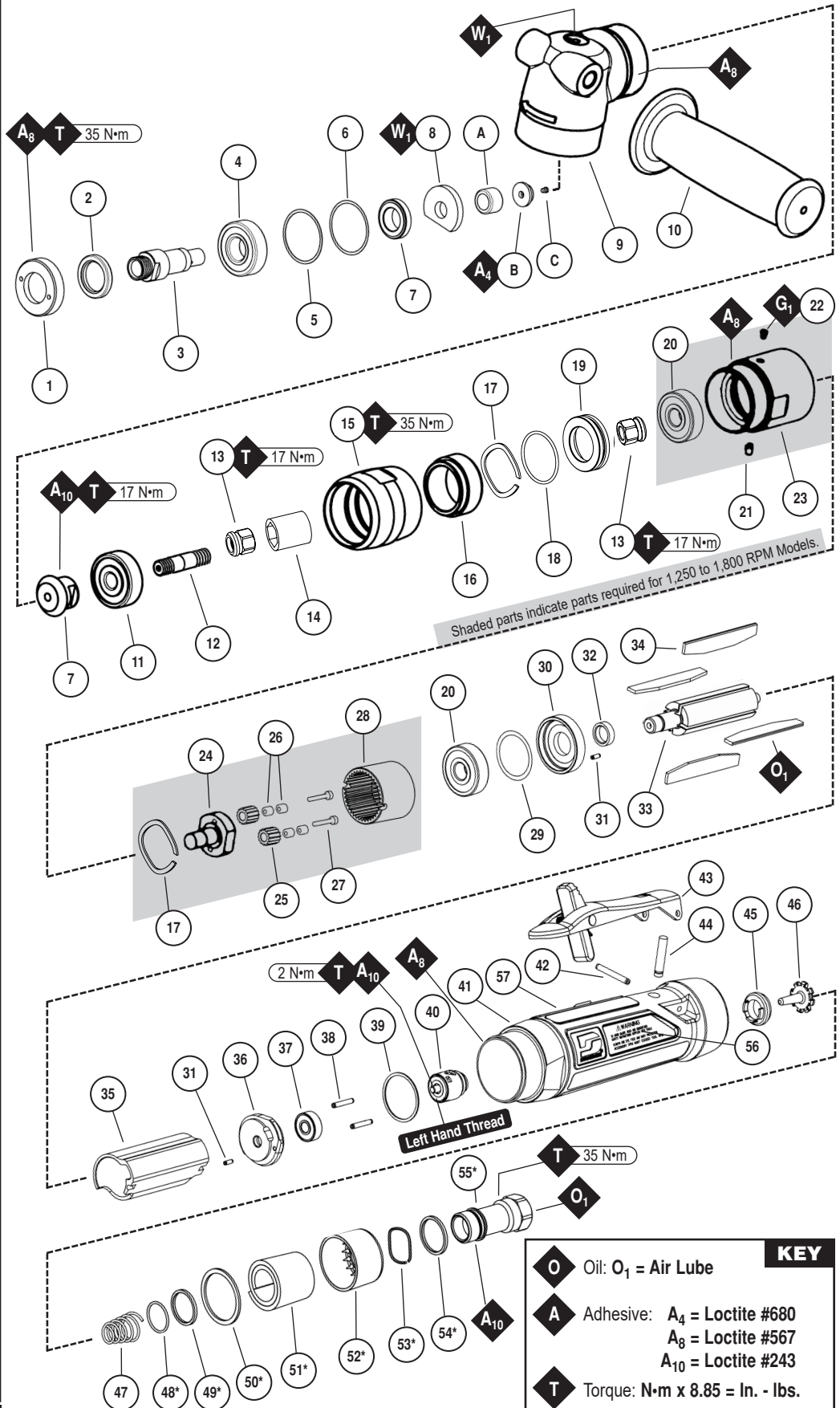

Note: All index numbers with an asterisk are included in P/N 53655 Muffler Assembly.

Label Key

No.	Part #	Description
56	00001180	Warning Label
57	00001181	Specification Label

KEY	
O	Oil: O ₁ = Air Lube
A	Adhesive: A ₄ = Loctite #680 A ₈ = Loctite #567 A ₁₀ = Loctite #243
T	Torque: N·m x 8.85 = In. - lbs.
W	Wicking: W ₁ = Gear Oil
G	Grease: G ₁ = Lubriplate 630 AA

Disassembly Instructions - 1hp Right Angle Buffer/Polisher

Important: Manufacturer's warranty is void if tool is disassembled before warranty expires.

Disconnect tool from power source before tool repair.

Right Angle Head Disassembly:

1. Remove side handle and polishing pad.
2. Secure **53600** Right Angle Housing, against both side handle bosses, in a padded vise with spindle facing upward.
3. Using **97782** Pin Wrench (*ordered separately*) or an adjustable pin wrench, remove **50963** Retainer. (**Left Hand Threads**)
4. Remove **50899** Shaft Seal from retainer.
5. Pull spindle and gear assembly from housing.
6. Press spindle through **97679** Bearing and spiral bevel gear.
7. Remove shims and **53608** Wick from right angle housing.
8. Remove **53650** Lock Ring from right angle housing (**Left Hand Threads**) and from **53695** Gear Casing (**Right Hand Threads**). **Note:** For 4,500 RPM models, remove lock ring from motor housing (**Right Hand Threads**).
9. Remove angle head from vise and remove **96325** Bearing by pressing **53649** Gear Oil Plate through housing.
10. Pull pinion gear, bearing and coupler sub-assembly from angle housing.
11. Secure gear, bearing and coupler sub-assembly by the pinion gear wrench flats and remove the **51969** Flexible Coupler (twist counterclockwise).
12. Secure **53635** Adapter using an allen wrench and remove pinion gear (twist counterclockwise).
13. Press **53635** Adapter through **01266** Bearing.

Note: For 4,500 RPM models, omit steps 14 through 17.

14. Remove **04014** Set Screw from **53695** Gear Casing and remove gear casing (**Right Hand Thread**) from motor housing.
15. Slide **53665** Ring Gear from gear casing.
16. Secure planetary carrier using **53698** Wrench (*ordered separately*) and remove **51969** Coupler Nut (twist counterclockwise).
17. Press planetary carrier thread end through **54520** Bearing.
18. Remove **96498** Wave Spring.
19. Press **53679** Pins from carrier to remove gears.

Right Angle Head Disassembly Complete.

Motor Disassembly:

1. Remove **53651** Spacer and **96498** Wave Spring from housing assembly.
2. Pull motor assembly from housing.
3. Remove **53620** Motor Adapter with **95438** O-Ring. **Note:** Step 3 applies to 4,500 RPM models only.
4. Remove governor assembly by using a slotted screwdriver. (**Left Hand Thread**)
5. Secure **51925** Cylinder using **96209** Motor Repair Clamp (*ordered separately*) and place a 1/8" (3 mm) drift pin to the base of the terminal thread and press **51921** Rotor from the **02057** Rear Bearing.
6. Slide **02057** Rear Bearing from **51923** Rear Bearing Plate.
7. Remove **51925** Cylinder and **51926** Blades.
8. Secure **51921** Rotor in a padded vise and remove **51969** Coupler Nut (twist counterclockwise). **Note:** Steps 8 applies to 4,500 RPM models only.
9. Press rotor through **54520** Bearing, **51922** Front Bearing Plate and **51927** Rotor Spacer.
10. Slide **54520** Bearing and shims from **51922** Front Bearing Plate.

Motor Disassembly Complete.

Housing Disassembly:

1. Secure housing using **51989** Repair Collar (*see back cover for Optional Accessories*).
2. Remove inlet bushing with muffler assembly (twist counterclockwise).
3. Remove **53682** Gasket, **51943** Spring, **96442** O-Ring, **51940** Spacer, **94528** Felt Silencer, **53686** Muffler Cap, **94924** Wave Spring and **53683** Spacer from **53681** Inlet Bushing.
4. Remove **51944** Tip Valve and **51945** Valve Seat.
5. Remove housing and **51989** Repair Collar and lay collar on bench with flange facing down so it is supporting throttle lever. Place a 3/32" (3 mm) drift pin on **96444** Pin and tap pin thru housing.
6. Remove **51946** Valve Stem Assembly.
7. Remove **96443** O-Ring from **51946** Valve Stem Assembly.

Housing Disassembly Complete.

Assembly Instructions - 1hp Right Angle Buffer/Polisher

Motor Assembly:

Important: Be sure parts are clean and in good repair before assembling. Follow grease, oil and torque specifications.

1. Place rotor into a padded vise with gear teeth or male thread facing upwards.
2. Slip **51927** Rotor Spacer over rotor shaft and down against rotor body face.
3. Press **96441** Coiled Pin into **51922** Front Bearing Plate. Make certain, coiled pin does not protrude beyond internal bearing surface.
4. Place a .002" shim into the base of **51922** Front Bearing Plate as an initial spacing and slide **54520** Bearing to the front plate base. **Note:** **51951** Shim Pack contains .001" and .002" shims.
5. Slip bearing/bearing plate assembly onto rotor. Add one drop of Loctite® #243 (or equiv.) to **51921** Rotor 3/8-24 male thread and screw **51969** Coupler Nut into place (Torque to 17 N•m 150 lb.-in.). **Note:** Step 5 applies to 4,500 RPM models only, omit step 6.
6. Press Bearing/Bearing Plate assembly onto rotor.
7. Check clearance between rotor and front bearing plate by using a .001" feeler gauge. Clearance should be between .001" – .0015". Adjust clearance by repeating steps 4,5 and 6 with different shims if necessary.
8. Once proper rotor gap clearance is achieved, install well lubricated **51926** Blades (4) into rotor slots. Dynabrade recommends lubricating blades with **95842** Air Lube.
9. Install **51925** Cylinder over rotor and front plate raised boss. Align coiled pin on front plate to cylinder slot.
10. Press **96441** Coiled Pin into blind hole on **51923** Rear Bearing Plate. Press (2) **96445** Coiled Pins into the back side of rear bearing plate.
11. Peel backing off **51924** Gasket and apply it firmly in place onto **51923** Rear Bearing Plate.
12. Place **51923** Rear Bearing Plate over rotor mandrel and insert raised boss on rear bearing plate into cylinder diameter, while inserting short coiled pin into cylinder slot. Be sure inlet slot on rear bearing plate lines up with inlet slot on cylinder. To correct alignment flip cylinder end to end and repeat step 9 for correct assembly.
13. Using **96243** Bearing Press Tool (*ordered separately*) press **02057** Bearing onto rotor and into **51923** Rear Bearing Plate hole until it is seated. **Important:** Cylinder must fit snug between bearing plates. If too tight, rotor will not turn freely. Rotor must be lightly tapped at press fit end until rotor spins freely while still maintaining a snug fit. A loose fit will not achieve the proper preload on motor. While pressing **02057** Bearing, make certain to contact inner race of bearing.

Assembly Instructions - (Continued)

Important: Manufacturer's warranty is void if tool is disassembled before warranty expires.

Please refer to parts breakdown for part identification.

14. Add one drop of Loctite® #243 (or equiv.) to governor assembly male thread and screw governor assembly into place (**Left Hand Thread**) with slotted screw head. Torque to 2 N•m (18 lb.-in.).
15. Install motor assembly into housing, making sure motor drops all the way into housing. **Note:** Align both **96445** Coiled Pins to slots in insert and against **51924** Gasket.

Motor Assembly Complete.

Right Angle Head Assembly:

1. Press **01041** Gear Oil Fitting into **53649** Gear Oil Plate. Apply a drop of Loctite #680 (or equivalent) to the diameter of the gear oil plate and insert sub-assembly into right angle housing.
2. Press **96325** Bearing into housing until it is firmly seated against **53649** Gear Oil Plate. **Important:** While pressing **96325** Bearing, make certain to contact outer race of bearing only.
3. Add one drop of Loctite® #243 (or equiv.) to male thread of **53635** Adapter and tighten pinion using a 3/16" Hex Key wrench and the pinion wrench flats. Torque to 17 N•m (150 lb.-in.).
4. Using **96244** Bearing Press Tool (*ordered separately*) press **53635** Adapter into **01266** Bearing. **Important:** While pressing **01266** Bearing, make certain to contact inner race of bearing only.
5. Add one drop of Loctite® #243 (or equiv.) to male thread of adapter and tighten **51969** Coupler using wrench flats. Torque to 17 N•m (150 lb.-in.).
6. Insert sub-assembly into male threaded end of **53600** Right Angle Housing.
7. Apply a small amount of Loctite® #567 (or equiv.) to **53600** Right Angle Housing thread, and install **53650** Lock Ring (**Left hand Threads**).

Note: For 4,500 RPM models, omit steps 8 through 18, go to step 19.

8. Install **53665** Ring Gear over **54520** Front Motor Bearing, keeping 2 slots facing outward.
9. Install gears with needle bearings and assemble onto planetary carrier by pressing retainer shafts into place.
10. Place **96498** Wavy Washer at the base of **53695** Gear Casing female threaded end.
11. Slide planetary carrier assembly, with threaded end first, into **53695** Gear Casing and through **54520** Bearing.
12. Apply one drop of Loctite® #243 (or equiv.) to threads of **51969** Coupler Nut. Secure planetary carrier using **53698** Wrench (*order separately*) and thread on **51969** Coupler Nut (twist clockwise). Torque to 17 N•m (150 lb.-in.).
13. Apply a small amount of Loctite® #567 (or equiv.) to male thread of motor housing and thread **53695** Gear Casing over ring gear and onto motor housing. **Important:** Align rotor spline into planet gears to allow carrier to spin freely.
14. When slots from ring gear line up with set screw hole, apply a small amount of Loctite® #567 (or equiv.) to male thread of **04014** Set Screw, and install set screw to lock ring gear in place.
15. Torque **53695** Gear Casing to 35 N•m (310 lb.-in.).
16. Place **50902** Coupler onto **51969** Coupler Nut.
17. Secure **53600** Right Angle Housing, against both side handle bosses, in a padded vise.
18. Rotate motor housing/gear casing and **53650** Lock Ring until throttle lever is located between the 9-11 o'clock position. Throttle lever in this position safe guards against accidental start ups of the tool. Torque lock ring to 35 N•m (310 lb.-in.).

Note: Steps 19 through 26 apply to 4,500 RPM models only, for all other models go to step 27.

19. Install **95438** O-Ring onto **53620** Adapter and slide adapter into housing and over **54520** Bearing.
20. Place **96498** Wave Washer onto **53620** Adapter.
21. Place **50902** Coupler onto **51969** Coupler Nut.
22. Insert **53651** Spacer, with short length first, into **53650** Lock Ring and up against **01266** Bearing.
23. Apply a small amount of Loctite® #567 (or equiv.) to male thread of motor housing.
24. Align **50902** Coupler onto **51969** Coupler Nut in right angle head assembly and thread motor into **53650** Lock Ring (twist clockwise).
25. Secure **53600** Right Angle Housing, against both side handle bosses, in a padded vise.
26. Rotate motor housing and **53650** Lock Ring until throttle lever is located between the 9-11 o'clock position. Throttle lever in this position safe guards against accidental start ups of tool. Torque lock ring to 35 N•m (310 lb.-in.).
27. Place well lubricated **53608** Wick against **96325** Bearing with flat edge towards pinion gear. (Wick must be completely saturated with Dynabrade **95848** Gear Oil before installation). **Note:** Do not contaminate wick with any other oil or grease product.
28. Press **97679** Bearing onto spindle and against shoulder. **Important:** While pressing **97679**, make certain to contact inner race of bearing only.
29. Press gear, with teeth facing away from bearing, into spindle and against **97679** Bearing inner race.
30. Insert spindle assembly into **53600** Right Angle Housing until **97679** Bearing contacts housing shoulder.
31. Rotate spindle while pressing down into housing to check for gear alignment and backlash. Install shims as required (minimum backlash is recommended for maximum gear life. Make certain there is clearance throughout 360° revolution).
32. Press **50899** Shaft Seal into **50963** Retainer with base of seal facing outward.
33. Apply a small amount of Loctite® #567 (or equiv.) to the male thread of the retainer and thread into place. (**Left Hand Thread**)
34. Using **97782** Pin Wrench (*ordered separately*) or an adjustable pin wrench, torque retainer to 35 N•m (310 lb.-in.).

Housing Assembly:

1. Secure housing using **51989** Repair Collar (*see back cover for Optional Accessories*) with inlet facing upward.
2. Slide **96443** O-Ring onto **51946** Valve Stem and slide sub-assembly until o-ring passes through housing hole. Make certain valve stem assembly slides freely after the o-ring passes through the hole.
3. Install **51945** Valve Seat by aligning 3 male prongs with three deep slots on insert. Make certain valve seat is pressed flat against base of pocket. **Note:** Add a few drops of Dynabrade Air Lube (P/N **95842**) to pocket walls before inserting **51945** Valve Seat.
4. Install **51944** Tip Valve as shown.
5. Pre-assemble muffler, slide **53683** Spacer over **53681** Inlet Bushing and up against the hex head base. Slide **94924** Wave Spring over **53681** Inlet Bushing and up against spacer. Pre roll **94528** Felt and install it in **53686** Muffler Cap. Support felt in felt/muffler cap assembly and slide **53681** Inlet Bushing thru the inside until the muffler cap assembly seats against the **94924** Wave Spring. Flare the felt and place **51940** Spacer over male thread and set **96442** O-Ring into groove at the base of thread. Return felt to unflared form. Slide **51943** Spring into bushing and up to the two **51938** screens.
6. Place **53682** Gasket over felt silencer and against **53686** Muffler Cap.
7. Apply one drop of Loctite® #243 (or equiv.) to **53681** Inlet Bushing Thread.
8. Align small inside diameter of **51943** Spring to cone point on **51944** Tip Valve and thread inlet bushing and sub-assembly into place. Torque bushing to 35 N•m (310 lb.-in.).
9. Remove housing from **51989** Repair Collar and place repair collar onto the bench top with the part number identifier against the bench. Align the throttle lever holes to housing pinhole and rest the housing and throttle lever onto the legs of the repair collar. Press **96444** Coiled Pin into lever hole and center into housing.

Tool Assembly Complete. Please allow 30 minutes for adhesives to cure before operating tool.

Important: Before operating, place 2-3 drops of Dynabrade Air Lube (P/N **95842**) directly into inlet with throttle lever depressed. Operate tool for 30 seconds to allow air lube to properly lubricate internal motor components. Motor should now be tested for proper operation at 90 PSIG max. If tool operates at a higher RPM than marked on the tool or if vibration and sound levels seem abnormal, the tool should be serviced to correct the cause before use.

Preventative Maintenance Schedule

For All 1hp Right Angle Buffer/Polishers

This service chart is published as a guide to expectant life of component parts. The replacement levels are based on average tool usage over one year. Dynabrade Inc. considers one year usage to be 1,000 hours.

Parts Common to all Models:

LEGEND	
T	Part included in 96532 Tune-up Kit
X	Type of wear, no other comments apply.
L	Easily lost. Care during assembly/disassembly.
D	Easily damaged during assembly/disassembly.
R1	Replace each time tool is disassembled.
R2	Replace each second time tool is disassembled.



96532 – 1hp. Motor Tune-Up Kit

Index #	Part Number	Description	Number Required	High Wear 100%	Medium Wear 70%	Low Wear 30%	Non-Wear 10%
1	50963	Retainer	1				X
2	50899	Seal	1	R2			
3	See Pg.4	Spindle	1				X
4	97679	Bearing	1		X		
5	97678	Shim	1				X
6	97677	Shim	1				X
7	See Pg.4	Gear Set	1			X	
8	53608	Wick	1		X		
9	53600	Right-Angle Housing Assy.	1				X
A	96325	Shell Bearing	1		X		
B	53649	Gear Oil Plate	1				X
C	01041	Gear Oil Fitting	1				X
10	53163	Side Handle	1				X
11	01266	Bearing	1		X		
12	53635	Pinion Adapter	1				X
13	51969	Coupler Nut	2				X
14	50902	Coupler	1			X	
15	53650	Lock Ring	1				X
16	53651	Spacer	1				X
17	96498	Wave Spring	1		T, L		
18	95438	O-Ring	1				T, X
19	53620	Adapter	1				X
20	54520	Bearing	1		T, X		
21	04014	Set Screw	1		L		
22	01041	Grease Fitting	1			X	
23	53695	Adapter	1				X
24	See Pg.4	Carrier	1			X	
25	See Pg.4	Gear	2			X	
26	04026	Needle Bearing	4			X	
27	53679	Shaft	1			X	
28	53665	Ring Gear	1			X	
29	51951	Shim Pack	1		T, L		
30	51922	Front Bearing Plate	1			X	
31	96441	Pin	2			X	
32	51927	Spacer	1		T, X		
33	See Pg.4	Rotor	1			X	
34	51926	Blade (4/pkg.)	1	T, X			
35	51925	Cylinder	1			X	
36	51923	Rear Bearing Plate	1			X	
37	02057	Bearing	1		T, X		
38	96445	Pin	2			X	
39	51924	Gasket	1		T, X		
40	See Pg.4	Governor Assembly	1				X
41	See Pg.4	Housing	1				X
42	96444	Pin	1		T, L		
43	51949	Safety Lever Assembly	1			X	
44	51946	Valve Stem Assembly (Includes 96443 O-Ring)	1		T, X		
45	51945	Valve Seat	1				X
46	51944	Tip Valve	1		T, X		
47	51943	Spring	1				X
48	96442	O-Ring	1		T, L		
49	51940	Spacer	1				X
50	53682	Gasket	1				X
51	94528	Felt Silencer	1	T, R1			
52	53686	Muffler Cap	1				X
53	94924	Wave Spring	1				X
54	53683	Spacer	1				X
55	53681	Inlet Bushing (Incl. 2 – 51938 Screens)	1				X

Optional Accessories



DYNASWIVEL®

- Swivels 360° AT TWO PIVOT POINTS allowing the air hose to drop directly to the floor while providing superb tool handling.

95461 – 3/8" NPT

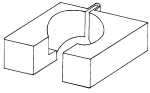

51989 Repair Collar

- Specially designed collar for use in vise to prevent damage to valve body of tool during disassembly/assembly.



DYNABRADE Air Lube

- Formulated for pneumatic equipment.
- Absorbs up to 10% of its weight in water.
- Prevents rust and formation of sludge.
- Keeps pneumatic tools operating longer with greater power and less down time.

95842: 1pt. (473 ml)

95843: 1gal. (3.8 L)



Bearing Press Tool

- Used to install bearings.

96243: For installing 02057 Bearing.

96244: For installing 01266 Bearing.



DYNABRADE Angle Gear Oil

- Specifically formulated to saturate wick system in right angle gear head.

95848: 2 oz. tube

95849: 10 oz. tube

95541: Push-Type Gear Oil Gun



97782 Retainer Repair Tool

- Tool has a 3/8 in. square socket for use with 3/8 in. drive; breaker bar, ratchet head, or torque wrenches.



96209 Motor Repair Clamp

- Specially designed clamp to secure motor cylinder before disassembly.

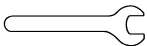

95263 – 17 mm open-end wrench.

95281 – 19 mm open-end wrench.



53209 Ergo-Handle

- Increases operators comfort when using unbalanced wheels.

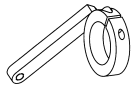

50984 Top Handle Assembly



96532 Motor Tune-Up Kit

- Includes assorted parts to help maintain and repair motor.

01902 Drop-In Motor - 4,500 RPM

01904 Drop-In Motor - 2,800 RPM

01905 Drop-In Motor - 1,250 - 1,800 RPM

- Allows quick and easy replacement. No motor adjustments needed.



53621 Over Hose Assembly

- Over Hose Assembly directs exhaust away from operator.



30335 Air Supply Hose

- 3/8 in. I.D. x 60 in. Wide air supply hose, includes: 3/8 in. NPT male and female threaded fittings.



53698 Carrier Wrench

- Carrier Wrench has a 3/8 in. square socket for use with 3/8 in. drive; breaker bar, ratchet head, or torque wrenches.



95542 Grease 10 oz.

- Multi-purpose grease for all types of bearings, cams, gears.
- High film strength; excellent resistance to water, steam, etc.
- Workable range 0° F to 300° F.

95541 Push-type Grease Gun

- One-hand operation.



6" Disc Pads (3,200 RPM Max.)

50828 (5/8"-11) - Foam-Backed Rubber-Face Soft Pad for PSA.

57545 (5/8"-11) - Hook-Face Pad for Reattachable Discs.

7-1/4" Disc Pads (3,200 RPM Max.)

50853 (5/8"-11) - Hook-Face Pad for Reattachable Discs.

50854 (M14x2) - Hook-Face Pad for Reattachable Discs.

8" Disc Pads (3,200 RPM Max.)

50829 (5/8"-11) - Foam-Backed Rubber-Face Soft Pad for PSA.

50947 (5/8"-11) - Hook-Face Pad for Reattachable Discs.

