



DYNABRADE[®]



INNOVATIVE AUTOMOTIVE AFTERMARKET PRODUCTS

Dynabrade Warranty Information

Dynabrade Pneumatic Tools Lifetime Warranty

Tools purchased beginning August 18, 2008 may be registered for Lifetime Warranty. Lifetime Warranty applies only to portable pneumatic tools manufactured by Dynabrade, Inc. in the USA. Warranty applies only to the original tool owner; warranty is non-transferable.

All Dynabrade portable pneumatic power tools are rigorously inspected and performance tested in our factory before shipping to our customers.

Dynabrade warrants all Dynabrade portable pneumatic power tools against defects of workmanship and materials under normal use and service for the lifetime of the tool as set forth herein.

Upon examination and review at Dynabrade's factory, Dynabrade shall confirm whether the tool qualifies for warranty status, in which case Dynabrade will repair or replace the tool at no charge to the customer.

This warranty is contingent upon proper use of the tool in accordance with factory recommendations, instructions and safety practices. It shall not apply to equipment that has been subjected to misuse, negligence, accident or tampering in any way so as to affect its normal performance.

This warranty does NOT cover normally wearable parts and accessories, including, but not limited to, bearings, contact wheels, rotor blades, regulators, valve stems, levers, shrouds, guards, O-rings, seals, gaskets and other wearable parts. Dynabrade only warrants such normally wearable parts and accessories against manufacturing defects at the time of receipt. If, upon receipt and prior to use, a normally wearable part or accessory is found to be defective, Dynabrade will repair or replace such part or accessory at no charge to the customer.

Dynabrade will not honor Lifetime Warranty on unregistered tools. A one-year warranty will be honored on all unregistered portable pneumatic power tools. (In European countries, warranty on unregistered tools will be two years.) Customer must return the defective unregistered tool to Dynabrade within one year (or two years in European countries) from the date of purchase.

To be considered for warranty, tools must be sent back to our factory, transportation prepaid by user. Please send tool back to attention "Repair Department" with note fully explaining the nature of the problem along with a copy of original invoice indicating model and serial number.

THIS WARRANTY IS MADE IN LIEU OF ALL OTHER WARRANTIES, EXPRESS OR IMPLIED, INCLUDING, BUT NOT LIMITED TO, WARRANTIES OF MERCHANTABILITY OR FITNESS FOR A PARTICULAR PURPOSE, AND THERE ARE NO OTHER WARRANTIES THAT EXTEND BEYOND THIS EXPRESS WARRANTY.

Dynabrade will not be liable for damages to products, other property or persons due to improper use or through attempts to use products for other than their intended use. DYNABRADE WILL NOT BE LIABLE TO CUSTOMER OR ANY THIRD PARTY FOR ANY SPECIAL, CONTINGENT, INCIDENTAL, INDIRECT OR CONSEQUENTIAL DAMAGES. Dynabrade's liability with respect to a claim for any other damages arising out of or connected with the manufacture, sale, purchase, non-delivery, use or performance of any product sold by Dynabrade will in no event exceed to the price paid for the product.

Dynabrade Autobrade Red® Tools 6-Month Warranty

Dynabrade warrants all "Autobrade Red®" tools against defects in workmanship and materials under normal use and service for a period of 6 months from the date of purchase as set forth herein.

Customer must return the defective tool to Dynabrade within 6 months from the date of purchase. Upon examination and review at Dynabrade's factory, Dynabrade shall confirm whether the tool qualifies for warranty status, in which case Dynabrade shall repair or replace the tool at no charge to the customer.

This warranty is contingent upon proper use of the "Autobrade Red®" tool in accordance with factory recommendations, instructions and safety practices. It shall not apply to equipment that has been subjected to misuse, negligence, accident or tampering in any way so as to affect its normal performance. This warranty does NOT apply in the following cases: (i) consumables such as sanding pads, etc.; (ii) lack of lubrication or evidence of rust, dirt or corrosion; (iii) tools requiring normal tune-up or cleaning; (iv) tools being used after they are badly worn such as using ratchet with worn yoke; (v) ratchet anvils damaged by excessive hand torquing; (vi) use in production-type applications.

This warranty does NOT cover normally wearable parts and accessories, including, but not limited to, bearings, contact wheels, rotor blades, regulators, valve stems, levers, shrouds, guards, O-rings, seals, gaskets and other wearable parts. Dynabrade only warrants such normally wearable parts and accessories against manufacturing defects at the time of receipt. If, upon receipt and prior to use, a normally wearable part or accessory is found to be defective, Dynabrade will repair or replace such part or accessory at no charge to the customer.

To be considered for warranty, tools must be sent back to our factory, transportation prepaid by user. Please send tool back to attention "Repair Department" with note fully explaining the nature of the problem along with a copy of original invoice indicating model and serial number.

THIS WARRANTY IS MADE IN LIEU OF ALL OTHER WARRANTIES, EXPRESS OR IMPLIED, INCLUDING, BUT NOT LIMITED TO, WARRANTIES OF MERCHANTABILITY OR FITNESS FOR A PARTICULAR PURPOSE, AND THERE ARE NO OTHER WARRANTIES THAT EXTEND BEYOND THIS EXPRESS WARRANTY.

Dynabrade will not be liable for damages to products, other property or persons due to improper use or through attempts to use products for other than their intended use. DYNABRADE WILL NOT BE LIABLE TO CUSTOMER OR ANY THIRD PARTY FOR ANY SPECIAL, CONTINGENT, INCIDENTAL, INDIRECT OR CONSEQUENTIAL DAMAGES. Dynabrade's liability with respect to a claim for any other damages arising out of or connected with the manufacture, sale, purchase, non-delivery, use or performance of any product sold by Dynabrade will in no event exceed to the price paid for the product.

Dynabrade Electric Tools 6-Month Warranty

Dynabrade warrants all electric tools against defects in workmanship and materials under normal use and service for a period of 6 months from the date of purchase. All conditions of "Autobrade Red" tool 6-month warranty also apply to Dynabrade electric tools.

Dynabrade 90-Day Warranty on Reconditioned and Repaired Tools

All reconditioned and repaired tools manufactured by Dynabrade have been refurbished by Dynabrade's factory experts, and have undergone rigorous testing to ensure that they meet our high standards of quality.

Dynabrade warrants all reconditioned and repaired tools manufactured by Dynabrade against defects in workmanship and materials under normal use and service for a period of 90 days from the date of purchase as set forth herein.

Customer must return the defective tool to Dynabrade within 90 days from the date of purchase. Upon examination and review at Dynabrade's factory, Dynabrade shall confirm whether the tool qualifies for warranty status, in which case Dynabrade shall repair or replace the tool at no charge to the customer.

This warranty is contingent upon proper use of the reconditioned and repaired tool in accordance with factory recommendations, instructions and safety practices. It shall not apply to equipment that has been subjected to misuse, negligence, accident or tampering in any way so as to affect its normal performance.

This warranty does NOT cover normally wearable parts and products, including, but not limited to, bearings, contact wheels, rotor blades, regulators, valve stems, levers, shrouds, guards, O-rings, seals, gaskets and other wearable parts. Dynabrade only warrants such normally wearable parts and accessories against manufacturing defects at the time of receipt. If, upon receipt and prior to use, a normally wearable part or accessory is found to be defective, Dynabrade will repair or replace such part or accessory at no charge to the customer.

To be considered for warranty, tools must be sent back to our factory, transportation prepaid by user. Please send tool back to attention "Repair Department" with note fully explaining the nature of the problem along with a copy of original invoice indicating model and serial number.

THIS WARRANTY IS MADE IN LIEU OF ALL OTHER WARRANTIES, EXPRESS OR IMPLIED, INCLUDING, BUT NOT LIMITED TO, WARRANTIES OF MERCHANTABILITY OR FITNESS FOR A PARTICULAR PURPOSE, AND THERE ARE NO OTHER WARRANTIES THAT EXTEND BEYOND THIS EXPRESS WARRANTY.

Dynabrade will not be liable for damages to products, other property or persons due to improper use or through attempts to use products for other than their intended use. DYNABRADE WILL NOT BE LIABLE TO CUSTOMER OR ANY THIRD PARTY FOR ANY SPECIAL, CONTINGENT, INCIDENTAL, INDIRECT OR CONSEQUENTIAL DAMAGES. Dynabrade's liability with respect to a claim for any other damages arising out of or connected with the manufacture, sale, purchase, non-delivery, use or performance of any product sold by Dynabrade will in no event exceed to the price paid for the product.

Dynabrade Portable Vacuums Two-Year Warranty

Dynabrade warrants all Portable Vacuums manufactured by Dynabrade against defects in workmanship and materials under normal use and service for a period of 2 years from the date of purchase as set forth herein.

Customer must return the defective vacuum to Dynabrade within 2 years from the date of purchase. Upon examination and review at Dynabrade's factory, Dynabrade shall confirm whether the vacuum qualifies for warranty status, in which case Dynabrade shall repair or replace the vacuum at no charge to the customer.

This warranty is contingent upon proper use of the Portable Vacuum in accordance with factory recommendations, instructions and safety practices. It shall not apply to equipment that has been subjected to misuse, negligence, or accident, such as using incorrect filters. It shall also not apply to equipment that has been tampered with in any way so as to affect its normal performance.

This warranty does NOT cover normally wearable parts and products, including, but not limited to, electrical motor brushes, hoses, couplers, filters, dust bags and other wearable parts. Dynabrade only warrants such normally wearable parts and accessories against manufacturing defects at the time of receipt. If, upon receipt and prior to use, a normally wearable part or accessory is found to be defective, Dynabrade will repair or replace such part or accessory at no charge to the customer.

To be considered for warranty, vacuums must be sent back to our factory, transportation prepaid by user. Please send vacuum back to attention "Repair Department" with note fully explaining the nature of the problem along with a copy of original invoice indicating model and serial number.

THIS WARRANTY IS MADE IN LIEU OF ALL OTHER WARRANTIES, EXPRESS OR IMPLIED, INCLUDING, BUT NOT LIMITED TO, WARRANTIES OF MERCHANTABILITY OR FITNESS FOR A PARTICULAR PURPOSE, AND THERE ARE NO OTHER WARRANTIES THAT EXTEND BEYOND THIS EXPRESS WARRANTY.

Dynabrade will not be liable for damages to products, other property or persons due to improper use or through attempts to use products for other than their intended use. DYNABRADE WILL NOT BE LIABLE TO CUSTOMER OR ANY THIRD PARTY FOR ANY SPECIAL, CONTINGENT, INCIDENTAL, INDIRECT OR CONSEQUENTIAL DAMAGES. Dynabrade's liability with respect to a claim for any other damages arising out of or connected with the manufacture, sale, purchase, non-delivery, use or performance of any product sold by Dynabrade will in no event exceed to the price paid for the product.

Table of Contents

Random Orbital Sanders

Palm-Style Dynorbital-Spirit®	4-6
Mini-Dynorbital®	6
HiVac Dynorbital-Spirit®	7
Dynorbital® Silver Supreme	8-10
Mini-Dynorbital® Silver Supreme	10
Two-Hand Dynorbital®	11
11" Diameter Sanders	12
Random Orbital Sander Accessories/Sanding Pads.....	42, 54-56

"Mud Hog" Sanders

6" & 8" Diameter Sanders	13
11" Diameter Sanders	14

Combination Disc Sander/Random Orbital

DynaLocke® Dual-Action Sander	15
-------------------------------------	----

Dynabug® "Model T" Sanders

16

Wet Sanders

Dynabug® "Model T"	17
Random Orbitals	18
Dynafine®	19

Board Sanders

Dynabug®	20
Dynabug® II	20
8" Dynaline In-Line.....	21
11" Dynaline In-Line.....	22

Detailing Tools

Dynorbital® Supreme Scrubber.....	22
Palm-Style Mini-Dynorbital® Buffers.....	23
7"-8" Electric Rotary Buffer	24
7"-8" Random Orbital Buffers	25
"Two-Step" Spot Repair System.....	26
Dynafine® Detail Sander.....	27
Dynafine® Finger Sander	27
DynaPen Filer Kit	31

Heavy Duty Tools

Disc Sanders	28
Cut-Off Tool	28
Die Grinders.....	28
Drill	28
Mini-Dynafine® II Abrasive Belt Tool	29
Buffers.....	29

Electric Tools

Dynafine® II Abrasive Belt Tool	30
Depressed Center Wheel Grinder	30
7"-8" Rotary Buffer	24
7"-8" Random Orbital Buffer	25
11" Random Orbital Sanders	12

Autobrade Red®

Abrasive Belt Tool	31
RED-TRED® Eraser Disc Tools.....	32
Pistol Grip Buffer	32
DynaZip	33
Die Grinders, Die Grinder/Disc Sander Kit.....	34
Disc Sanders	35
Cut-Off Wheel Tools	35
Dual-Piston Sander	35
Buffers.....	36

Accessories

Dynaswivel® Air Line Connectors	37
Ported Plugs and Couplers, Test Gauge	38-40
Blow Guns, Tool Oil, Grease, Finesse Compound.....	41
Random Orbital Sander Accessories	42
Random Orbital Head Kits, Hook-Face Pads, Carbide Burrs.....	43
F-R-L's, Locking-Type Pads, Buffing Pads.....	44
RED-TRED® Disc and Wheel, DynaZip Accessories	45
Threaded Adapters, DynaMitt, Mini-Dynorbital® Sanding Pads	45

Downdraft Sanding Tables

46

Portable Vacuum Systems

47

Portable Vacuum Accessories.....	48
Vacuum Hose and Cuffs	49-51
Air Line Accessories	51-52
Vacuum Accessories.....	53-54

Replacement Sanding Pads.....

54-58

Interface Pads / Pad Conversions

59

Point-of-Purchase Accessories

60-62

Dynabrade Product Information

63

Tool Performance Assurance

64-65

Numerical Index of Tools

66-67

Dynorbital-Spirit® Random Orbital Sander

Our Lightweight Sander Offers Many Advantages!

Compact Grip Size

Ideal for operators with smaller hands, and for use in vertical applications!

Single-Piece Locking Ring

Allows easier assembly and provides tighter seal.

Perfectly Balanced Sanding Pad

Ask for the ORANGE!

Perfectly-balanced, weight-mated sanding pad with exclusive **one-piece hub design**. Dynabrade premium urethane pads offer smoother operating performance and minimal vibration.

3" (76 mm) – 75 grams

3-1/2" (89 mm) – 80 grams

5" (127 mm) – 100 grams

6" (152 mm) – 130 grams

Auto-Recess Throttle Lever

Lever recesses into housing grip when depressed, eliminating pressure-point on operator's palm. Lever is made from composite material to insulate against cold air. Lever is color-coded to identify tool orbit (see page 5).

Comfort Platform

U.S. Patent No. D610,428

Provides additional hand and wrist support, enhancing operator comfort. Also offers protection against cold air exhaust.

ONE-HAND Speed Control

Speed Control dial allows "thumb control" regulating of tool speed.

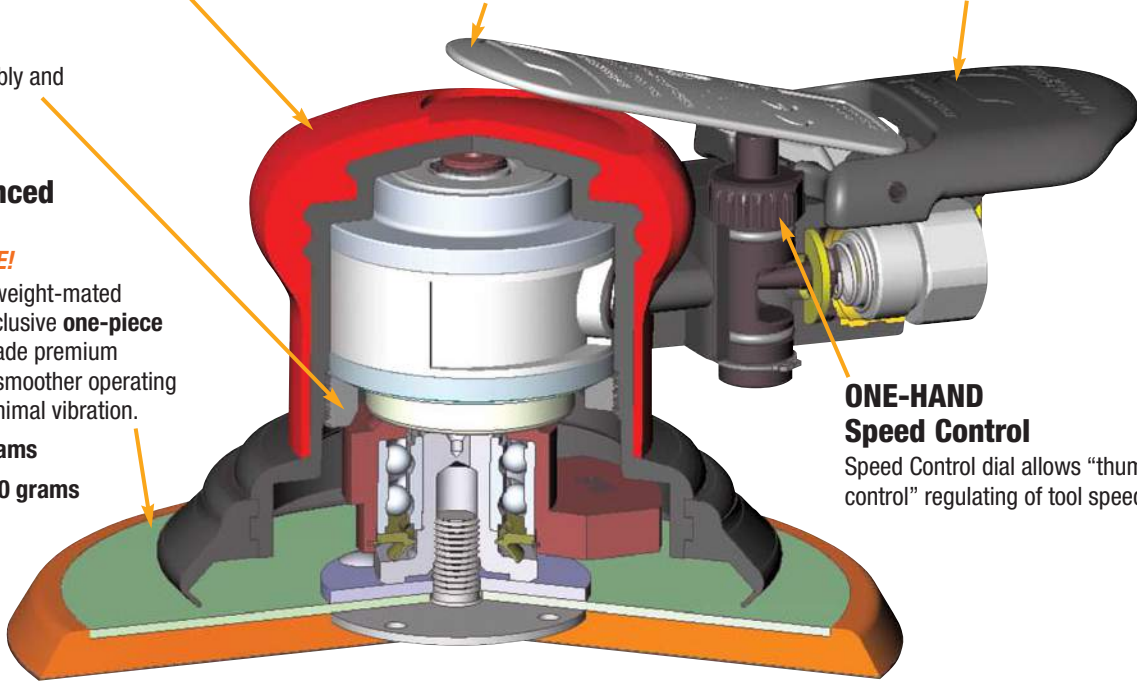

Enhanced Vacuum Capabilities

Large port for maximum capture of dust and debris!



5" (127 mm) Dia.
Vacuum Shroud shown.

"Stays-Tight" Threaded Muffler

Remains firmly attached to tool during use.



Patented Bearing Protection

"V-Seal" bearing seal protects balancer shaft bearing from sanding residue, resulting in longer tool life.



"Top Hat" Seal

Protects front motor bearing from sanding residue, and holds in bearing lubrication while keeping out contaminants.

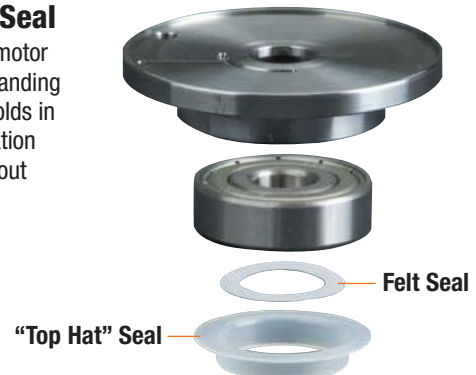

Dynorbital-Spirit® Models

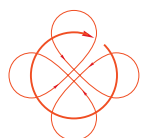

3/8"
(10 mm)
Diameter Orbit

For Aggressive Sanding



Look for **ORANGE** Throttle Lever

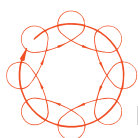

3/16"
(5 mm)
Diameter Orbit

For General Sanding



Look for **GREY** Throttle Lever

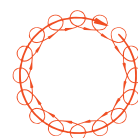

3/32"
(2 mm)
Diameter Orbit

For Ultra-Fine Sanding



Look for **BLACK** Throttle Lever

Non-Vacuum

- Includes low profile, premium urethane weight-mated PSA sanding pad.
- Optional vacuum conversion kits available, to easily convert non-vacuum tool to self-generated or central vacuum tool (see page 42).

Pad Diameter Inch (mm)	3/8" Orbit Models	3/16" Orbit Models	3/32" Orbit Models
3 (76 mm)	21000	21020	21040
3-1/2 (89 mm)	21005	21025	21045
5 (127 mm)	21010	21030	21050
6 (152 mm)	21015	21035	21055
6 w/Hook-Face Pad	21060	21061	21062

Tune-Up Kit: No. 96510



Model
21035

**SEE PAGE 55
FOR ORANGE
SANDING PADS!**

Self-Generated Vacuum

- Includes low profile, premium urethane weight-mated PSA sanding pad.
- Connects to portable self-contained dust collection system, included.

Pad Diameter Inch (mm)	3/8" Orbit Models	3/16" Orbit Models	3/32" Orbit Models
3 (76 mm)	21001	21021	21041
3-1/2 (89 mm)	21006	21026	21046
5 (127 mm)	21011	21031	21051
6 (152 mm)	21016	21036	21056

Tune-Up Kit: No. 96510



Model
21036

**50617 Portable Dust Collection
System Included! See page 53.**

Central Vacuum

- Includes low profile, premium urethane weight-mated PSA sanding pad.
- Has 1" outside diameter vacuum port, for easy connection to central vacuum or shop vac only.

Pad Diameter Inch (mm)	3/8" Orbit Models	3/16" Orbit Models	3/32" Orbit Models
3 (76 mm)	21004	21024	21044
3-1/2 (89 mm)	21009	21029	21049
5 (127 mm)	21014	21034	21054
6 (152 mm)	21019	21039	21059
6 w/Hook-Face Pad	21063	21064	21065

Tune-Up Kit: No. 96510



Model
21039

See page 6 for complete specifications of each Dynorbital-Spirit® model.

Dynorbital-Spirit® Random Orbital Sander

Dynorbital-Spirit® Specifications

Model Number	Vacuum Style	Tool Dia. Inch (mm)	Dia. Orbit Inch (mm)	Sound Level	Weight Pound (kg)	Length Inch (mm)
21005	Non-Vac	3-1/2 (89)	3/8 (10)	78 dB(A)	1.4 (.6)	6 (152)
21010	Non-Vac	5 (127)	3/8 (10)	82 dB(A)	1.5 (.7)	6-1/2 (165)
21015/21060	Non-Vac	6 (152)	3/8 (10)	82 dB(A)	1.6 (.7)	7 (178)
21025	Non-Vac	3-1/2 (89)	3/16 (5)	80 dB(A)	1.4 (.6)	6 (152)
21030	Non-Vac	5 (127)	3/16 (5)	80 dB(A)	1.4 (.6)	6-1/2 (165)
21035/21061	Non-Vac	6 (152)	3/16 (5)	81 dB(A)	1.5 (.7)	7 (178)
21045	Non-Vac	3-1/2 (89)	3/32 (2)	80 dB(A)	1.4 (.6)	6 (152)
21050	Non-Vac	5 (127)	3/32 (2)	79 dB(A)	1.4 (.6)	6-1/2 (165)
21055/21062	Non-Vac	6 (152)	3/32 (2)	80 dB(A)	1.5 (.6)	7 (178)
21000	Non-Vac	3 (76)	3/8 (10)	78 dB(A)	1.4 (.6)	6 (152)
21020	Non-Vac	3 (76)	3/16 (5)	80 dB(A)	1.4 (.6)	6-1/2 (165)
21040	Non-Vac	3 (76)	3/32 (2)	79 dB(A)	1.3 (.6)	7 (178)
21006	Self-Gen	3-1/2 (89)	3/8 (10)	87 dB(A)	1.5 (.7)	8-1/2 (216)
21011	Self-Gen	5 (127)	3/8 (10)	87 dB(A)	1.6 (.7)	8-1/2 (216)
21016	Self-Gen	6 (152)	3/8 (10)	86 dB(A)	1.7 (.7)	9 (229)
21026	Self-Gen	3-1/2 (89)	3/16 (5)	87 dB(A)	1.4 (.6)	8-1/2 (216)
21031	Self-Gen	5 (127)	3/16 (5)	85 dB(A)	1.5 (.7)	8-1/2 (216)
21036	Self-Gen	6 (152)	3/16 (5)	86 dB(A)	1.6 (.7)	9 (229)

Model Number	Vacuum Style	Tool Dia. Inch (mm)	Dia. Orbit Inch (mm)	Sound Level	Weight Pound (kg)	Length Inch (mm)
21046	Self-Gen	3-1/2 (89)	3/32 (2)	87 dB(A)	1.4 (.6)	8-1/2 (216)
21051	Self-Gen	5 (127)	3/32 (2)	84 dB(A)	1.5 (.6)	8-1/2 (216)
21056	Self-Gen	6 (152)	3/32 (2)	86 dB(A)	1.5 (.7)	9 (229)
21001	Self-Gen	3 (76)	3/8 (10)	87 dB(A)	1.5 (.7)	8-1/2 (216)
21021	Self-Gen	3 (76)	3/16 (5)	87 dB(A)	1.4 (.6)	8-1/2 (216)
21041	Self-Gen	3 (76)	3/32 (2)	87 dB(A)	1.4 (.6)	9 (229)
21009	Central	3-1/2 (89)	3/8 (10)	78 dB(A)	1.5 (.7)	7 (178)
21014	Central	5 (127)	3/8 (10)	82 dB(A)	1.5 (.7)	7-1/4 (184)
21019/21063	Central	6 (152)	3/8 (10)	83 dB(A)	1.6 (.7)	7-3/4 (197)
21029	Central	3-1/2 (89)	3/16 (5)	80 dB(A)	1.4 (.6)	7 (178)
21034	Central	5 (127)	3/16 (5)	81 dB(A)	1.5 (.6)	7-1/4 (184)
21039/21064	Central	6 (152)	3/16 (5)	82 dB(A)	1.6 (.7)	7-3/4 (197)
21049	Central	3-1/2 (89)	3/32 (2)	80 dB(A)	1.4 (.6)	7 (178)
21054	Central	5 (127)	3/32 (2)	81 dB(A)	1.4 (.6)	7-1/4 (184)
21059/21065	Central	6 (152)	3/32 (2)	81 dB(A)	1.5 (.7)	7-3/4 (197)
21004	Central	3 (76)	3/8 (10)	78 dB(A)	1.5 (.6)	7 (178)
21024	Central	3 (76)	3/16 (5)	80 dB(A)	1.4 (.6)	7-1/4 (184)
21044	Central	3 (76)	3/32 (2)	80 dB(A)	1.4 (.6)	7-3/4 (197)

Additional Specifications: Motor .25 hp (186 W) • Motor 12,000 RPM • Pad Thread 5/16"-24 Male • Air Inlet Thread 1/4" NPT
 Hose I.D. Size 1/4" (6 mm) • Air Flow Rate 14 SCFM/396 LPM • Height 3-1/2" (89 mm) • Air Pressure 90 PSIG (6.2 Bar)
 Sound Level is the pressure measurement according to the method outlined in ISO regulation ISO-15744

Bodyman Tool Kit

Model 21080

Includes:

- 21035 Dynorbital-Spirit® Random Orbital Sander (6" diameter, Non-Vacuum, 3/16" diameter orbit) with premium urethane, weight-mated sanding pad.
- 18010 Right Angle Die Grinder, see page 33 for details.
- Two value-line PSA sanding pads (6" diameter).
- Eight abrasive discs (6" diameter, 80, 120, 180 and 220 grit).
- Locking-type backup pad (2" diameter) for use with Die Grinder.
- One non-woven nylon disc (2" diameter, coarse).
- Three coated abrasive discs (2" diameter, 60, 80 and 120 grit).



Palm-Style Mini-Dynorbital® Sander

Model 10360

- Includes 54034 Random Orbital Sanding Head and 1-1/4" dia. medium sanding pad with sample micro-finishing film abrasive discs.
- 5,000 RPM, 3/16" orbit.
- Level dust nibs on clear coat finishes with ease – stop hand-sanding!
- 1-1/4" dia. discs confine sanding to smallest possible area. Eliminates need to refinish entire body panels.
- Easy to control, quiet and lightweight, adjustable speed control, rear exhaust.
- Combined orbital and random action provides ultra-smooth finishes.



Optional 3/4" PSA Pad (54017) also available.

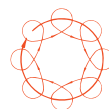

3/16" ORBIT
Random Action



Model Number	Motor RPM	Sound Level	Spindle Thread	Air Flow Rate CFM/SCFM	Air Inlet Thread	Hose Size	Air Pressure PSIG	Weight Pound	Length Inch	Height Inch
10360	5,000	70 dB(A)	1/4"-20 male	1/6	1/4" NPT	1/4"	90	1.7	5	3-5/8

HiVac 3" Dia. Dynorbital-Spirit® Models

- The combination of our unique shroud design and 3-hole sanding pad provide enhanced collection of dust and debris.
- No bulky sanding shroud to get in the way!
- A small tool with big power and vacuum capability.
- 3" diameter pad accepts Hook-Face or Mesh-Style abrasive discs.
- The random orbital action enables operator to achieve swirl-free finishes.
- Comfortable tool weight of only 1.3 lbs. minimizes operator fatigue.

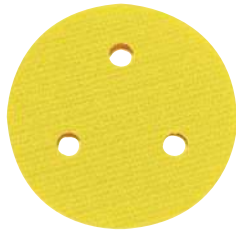
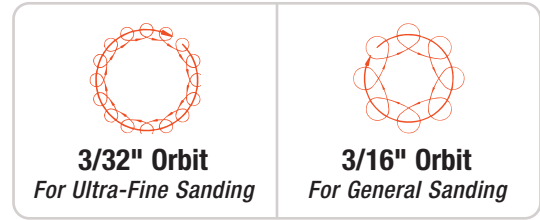

56114 Replacement Back-Up Pad
Medium Density.



Bottom View

↑ 1" Dia.
Vac Port



Model 21071

Compact shroud allows for maximum sanding and visibility near edges.

Self-Generated Vacuum

- Self-generated vacuum-ready models are ready for connection to portable dust collection systems (optional).

Orbit Diameter	Model Number
3/32"	21069
3/16"	21068



Model 21069

50617 Dust Collection System must be ordered separately. See page 53.

Central Vacuum

- Ready for hook-up to portable vacuum or central vacuum system.
- All models include combination lip seal/overskirt shroud, which offers enhanced vacuum capability and greater workpiece visibility.

Orbit Diameter	Model Number
3/32"	21071
3/16"	21070



Model 21071

Model Number	Motor hp	Motor RPM	Max. Air Flow CFM/SCFM	Hose I.D. Size Inch	Air Inlet Thread	Air Pressure PSIG	Spindle Thread	Weight Pound	Length Inch	Height Inch
21068/21069	.25	12,000	2/14	1/4	1/4" NPT	90	5/16"-24	1	7-3/4	3-3/4
21070/21071	.25	12,000	2/14	1/4	1/4" NPT	90	5/16"-24	1	6-1/2	3-3/4

Dynorbital® Silver Supreme

**Ideal for the Most Demanding Applications!
Combines Supreme Power with Lightweight Comfort!**

Compact Grip Size

Compact, ergonomic design is ideal for operators with smaller hands.

Auto-Recess Throttle Lever

Lever recesses into housing grip when depressed, eliminating pressure-point on operator's palm. Lever is made from composite material to insulate against cold air. Lever is color-coded to identify tool orbit (see page 9).

Comfort Platform

U.S. Patent No. D610,428

Provides additional hand and wrist support, enhancing operator comfort. Also offers protection against cold air exhaust.

Single-Piece Locking Ring

Allows easier assembly and provides tighter seal.

ONE-HAND Speed Control

New Speed Control dial allows "thumb control" regulating of tool speed. Also reduces accidental contact.

Perfectly Balanced Sanding Pad

Ask for the ORANGE!

Perfectly-balanced, weight-mated sanding pad with exclusive **one-piece hub design**. Dynabrade premium urethane pads offer smoother operating performance and minimal vibration.

3" (76 mm) – 75 grams

3-1/2" (89 mm) – 80 grams

5" (127 mm) – 100 grams

6" (152 mm) – 130 grams

Steel Cylinder and End Plates

Steel cylinder and end plates stay perfectly aligned. Design of end plates keeps more air in cylinder, increasing motor efficiency!

Enhanced Vacuum Capabilities

Large port for maximum capture of dust and debris!



3" (76 mm) Dia. Vacuum Shroud shown.

"Stays-Tight" Threaded Muffler

Remains firmly attached to tool during use.



LIGHTWEIGHT Design

Tool weighs only **1.8 lbs (.8 kg)**! Combines optimum comfort with heavyweight power!

Patented Bearing Protection

"V-Seal" bearing seal protects balancer shaft bearing from sanding residue, resulting in longer tool life.



"Top Hat" Seal

Protects front motor bearing from sanding residue, and holds in bearing lubrication while keeping out contaminants.



Dynorbital® Silver Supreme Models

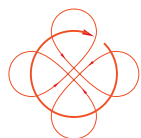

3/8"
(10 mm)
Diameter Orbit

For Aggressive Sanding



Look for **ORANGE** Throttle Lever

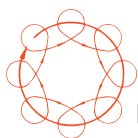

3/16"
(5 mm)
Diameter Orbit

For General Sanding



Look for **GREY** Throttle Lever

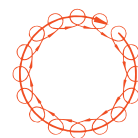

3/32"
(2 mm)
Diameter Orbit

For Ultra-Fine Sanding



Look for **BLACK** Throttle Lever

Non-Vacuum

- Includes low profile, premium urethane weight-mated PSA sanding pad.
- Optional vacuum conversion kits available, to easily convert non-vacuum tool to self-generated or central vacuum tool (see page 42).

Pad Diameter Inch (mm)	3/8" Orbit Models	3/16" Orbit Models	3/32" Orbit Models
3 (76 mm)	69100	69105	69110
3-1/2 (89 mm)	69000	69015	69030
5 (127 mm)	69005	69020	69035
6 (152 mm)	69010	69025	69040
6 w/Hook-Face Pad	69060	69061	69062

Tune-Up Kit: No. 96620



Model
69025

SEE PAGE 55
FOR **ORANGE**
SANDING PADS!

Self-Generated Vacuum

- Includes low profile, premium urethane weight-mated PSA sanding pad.
- Ready for connection to optional portable self-contained dust collection system.

Pad Diameter Inch (mm)	3/8" Orbit Models	3/16" Orbit Models	3/32" Orbit Models
3 (76 mm)	69103	69108	69113
3-1/2 (89 mm)	69003	69018	69033
5 (127 mm)	69008	69023	69038
6 (152 mm)	69013	69028	69043

Tune-Up Kit: No. 96620



Model
69028

50617 Portable Dust Collection System
(Optional - See Page 53)

Central Vacuum

- Includes low profile, premium urethane weight-mated PSA sanding pad.
- Has 1" outside diameter vacuum port, for easy connection to central vacuum or shop vac only.

Pad Diameter Inch (mm)	3/8" Orbit Models	3/16" Orbit Models	3/32" Orbit Models
3 (76 mm)	69104	69109	69114
3-1/2 (89 mm)	69004	69019	69034
5 (127 mm)	69009	69024	69039
6 (152 mm)	69014	69029	69044

Tune-Up Kit: No. 96620



Model
69029

See page 10 for complete specifications of each Dynorbital® Silver Supreme model.

Dynorbital® Silver Supreme

Dynorbital® Silver Supreme Specifications

Model Number	Vacuum Style	Tool Dia. Inch (mm)	Dia. Orbit Inch (mm)	Sound Level	Weight Pound (kg)	Length Inch (mm)
69000	Non-Vac	3-1/2 (89)	3/8 (10)	76 dB(A)	1.8 (.8)	6 (152)
69005	Non-Vac	5 (127)	3/8 (10)	79 dB(A)	1.9 (.9)	6-1/2 (165)
69010	Non-Vac	6 (152)	3/8 (10)	83 dB(A)	1.9 (.9)	7 (178)
69015	Non-Vac	3-1/2 (89)	3/16 (5)	77 dB(A)	1.7 (.8)	6 (152)
69020	Non-Vac	5 (127)	3/16 (5)	77 dB(A)	1.8 (.8)	6-1/2 (165)
69025	Non-Vac	6 (152)	3/16 (5)	77 dB(A)	1.8 (.8)	7 (178)
69030	Non-Vac	3-1/2 (89)	3/32 (2)	75 dB(A)	1.7 (.8)	6 (152)
69035	Non-Vac	5 (127)	3/32 (2)	77 dB(A)	1.7 (.8)	6-1/2 (165)
69040	Non-Vac	6 (152)	3/32 (2)	77 dB(A)	1.8 (.8)	7 (178)
69100	Non-Vac	3 (76)	3/8 (10)	79 dB(A)	1.8 (.8)	6 (152)
69105	Non-Vac	3 (76)	3/16 (5)	80 dB(A)	1.7 (.8)	6-1/2 (165)
69110	Non-Vac	3 (76)	3/32 (2)	80 dB(A)	1.7 (.8)	7 (178)
69003	Self-Gen	3-1/2 (89)	3/8 (10)	83 dB(A)	1.9 (.9)	8-1/2 (216)
69008	Self-Gen	5 (127)	3/8 (10)	80 dB(A)	2.0 (.9)	8-1/2 (216)
69013	Self-Gen	6 (152)	3/8 (10)	83 dB(A)	2.1 (.9)	9 (229)
69018	Self-Gen	3-1/2 (89)	3/16 (5)	82 dB(A)	1.8 (.8)	8-1/2 (216)
69023	Self-Gen	5 (127)	3/16 (5)	81 dB(A)	1.9 (.9)	8-1/2 (216)
69028	Self-Gen	6 (152)	3/16 (5)	83 dB(A)	2.0 (.9)	9 (229)

Model Number	Vacuum Style	Tool Dia. Inch (mm)	Dia. Orbit Inch (mm)	Sound Level	Weight Pound (kg)	Length Inch (mm)
69033	Self-Gen	3-1/2 (89)	3/32 (2)	83 dB(A)	1.8 (.8)	8-1/2 (216)
69038	Self-Gen	5 (127)	3/32 (2)	84 dB(A)	1.9 (.9)	8-1/2 (216)
69043	Self-Gen	6 (152)	3/32 (2)	81 dB(A)	2.0 (.9)	9 (229)
69103	Self-Gen	3 (76)	3/8 (10)	81 dB(A)	1.9 (.9)	8-1/2 (216)
69108	Self-Gen	3 (76)	3/16 (5)	82 dB(A)	1.8 (.8)	8-1/2 (216)
69113	Self-Gen	3 (76)	3/32 (2)	83 dB(A)	1.8 (.8)	9 (229)
69004	Central	3-1/2 (89)	3/8 (10)	79 dB(A)	1.9 (.9)	7 (178)
69009	Central	5 (127)	3/8 (10)	80 dB(A)	2.0 (.9)	7-1/4 (184)
69014	Central	6 (152)	3/8 (10)	84 dB(A)	1.9 (.9)	7-3/4 (197)
69019	Central	3-1/2 (89)	3/16 (5)	83 dB(A)	1.8 (.8)	7 (178)
69024	Central	5 (127)	3/16 (5)	83 dB(A)	1.9 (.9)	7-1/4 (184)
69029	Central	6 (152)	3/16 (5)	83 dB(A)	2.0 (.9)	7-3/4 (197)
69034	Central	3-1/2 (89)	3/32 (2)	81 dB(A)	1.8 (.8)	7 (178)
69039	Central	5 (127)	3/32 (2)	81 dB(A)	1.8 (.8)	7-1/4 (184)
69044	Central	6 (152)	3/32 (2)	82 dB(A)	2.0 (.9)	7-3/4 (197)
69104	Central	3 (76)	3/8 (10)	82 dB(A)	1.9 (.9)	7 (178)
69109	Central	3 (76)	3/16 (5)	82 dB(A)	1.8 (.8)	7-1/4 (184)
69114	Central	3 (76)	3/32 (2)	82 dB(A)	1.8 (.8)	7-3/4 (197)

Additional Specifications: Motor .26 hp (194 W) • Motor 12,000 RPM • Pad Thread 5/16"-24 Male • Air Inlet Thread 1/4" NPT
 Hose I.D. Size 1/4" (6 mm) • Air Flow Rate 16 SCFM/450 LPM • Height 3-1/2" (89 mm) • Air Pressure 90 PSIG (6.2 Bar)
 Sound Level is the pressure measurement according to the method outlined in ISO regulation ISO-15744



Mini-Dynorbital® Silver Supreme

Model 69503 5,000 RPM

- Ideal tool for spot repair using available 1-1/4" fine micro discs.
- Level dust nibs the easy way.
- 3/16" random orbit action. Includes hanger bracket (not shown).
- Compact, lightweight and low-profile design all make it fast and effective with proven results.
- Includes 54037 locking-type vinyl-face pad, 1-1/4" diameter.



Model Number	Motor hp	Motor RPM	Sound Level	Maximum Air Flow SCFM (LPM)	Tool Thread	Air Pressure PSIG	Hose I.D. Inch	Air Inlet Thread	Weight Pound	Length Inch	Height Inch
69503	.03	5,000	70 dB(A)	5 (153)	Locking	90	1/4	1/4" NPT	1.3	6	3-5/16

Two-Hand Dynorbital® Sanders

- Lightweight, with smooth performance.
- Adjustable-speed control.
- Includes our best PSA urethane, weight-mated sanding pad.
- Long handle provides excellent comfort and control, especially when working on vertical sides of workpiece.
- Composite tool housing and handle create non-slip feel and reduce cold air transmission to operator.
- Hook-face pads available on pages 55 and 56.

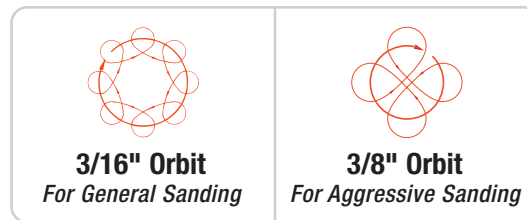

Non-Vacuum

- 5" and 6" models are 12,000 RPM. Pads have 5/16"-24 male spindle.
- 8" models are 10,000 RPM. Pads mount with screws.

Pad Diameter	3/16" Orbit Models	3/8" Orbit Models
5"	10710	10730
6"	10720	10733
8"	10725	N/A

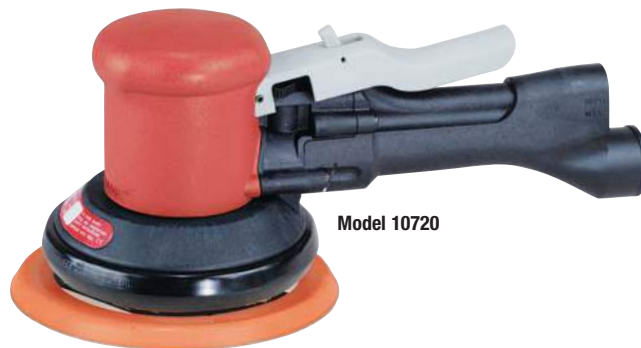

Vacuum-Ready

- Self-generated vacuum-ready models are ready for connection to portable dust collection systems (optional).

Pad Diameter	3/16" Orbit Models	3/8" Orbit Models
5"	10712	10731
6"	10722	10734
8"	10727	N/A



Central Vacuum

- Ready for hook-up to portable or central vacuum system.
- All models include combination lip seal/overskirt shroud, which offers enhanced vacuum capability and greater workpiece visibility.

Pad Diameter	3/16" Orbit Models	3/8" Orbit Models
6"	10724	10735
8"	10729	N/A



SEE PAGE 55 & 56 FOR ORANGE SANDING PADS!

Model Inch	Motor hp	Motor RPM	Orbit Dia. Inch	Maximum Air Flow CFM/SCFM	Hose I.D. Size Inch	Air Inlet Thread	Air Pressure PSIG	Weight Pound	Length Inch	Height Inch
5	.45	12,000	3/16	3/23	1/4	1/4" NPT	90	2.5	11-1/16	4-15/16
6	.45	12,000	3/16	3/23	1/4	1/4" NPT	90	5	11-3/8	4-15/16
8	.45	12,000	3/16	3/23	1/4	1/4" NPT	90	4	12-1/2	5-5/8

11" Random Orbital Sanders

- Sand large areas faster than ever! Smooth and controllable.
- Ideal for trucks, buses and emergency vehicles.
- All models include 56231 Hook-Face Pad and reversible side comfort handle.

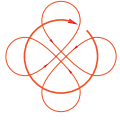

Large 3/4" diameter random orbital action makes the difference!



Pneumatic, Non-Vacuum

Model 58480

- Powerful 2,500 RPM, .7 hp air motor.
- Reversible side comfort handle.
- Insulated handle.

Pneumatic, Vacuum-Ready

Model 58485

- For use with "O" style abrasive discs, which allow dust to be drawn up through pad holes.
- For connection to external vacuum system.



Note: Interface Pads available on page 59.

Model Number	Motor hp	Motor RPM	Pad Dia. Inch	Maximum Air Flow CFM/SCFM	Hose I.D. Size Inch	Air Inlet Thread	Air Pressure PSIG	Weight Pound	Length Inch	Height Inch
58480	.7	2,500	11	3/27	3/8	1/4" NPT	90	8.3	17	6
58485	.7	2,500	11	3/27	3/8	1/4" NPT	90	9.1	17	6

Electric, Non-Vacuum

Model 51582

- 9 amp motor.
- 0 - 3,000 RPM with variable speed control – desired RPM can be locked-in with speed lock button.
- Comfort grip, three-position handle included.
- Smooth and controllable.
- Double-insulated housing, 8 ft. flexible cord, and built-in tool rest.



Electric, Vacuum-Ready

Model 51583

- For use with "O" style abrasive discs, which allow dust to be drawn up through pad holes.
- For connection to external vacuum system.

Model Number	Motor RPM	Pad Dia. Inch	Voltage	Current	Phase	Frequency	Weight Pound	Length Inch	Height Inch
51582	0 - 3,000	11	120 V (AC)	9 Amp.	1	60 Hz	11.3	21	7-5/16
51583	0 - 3,000	11	120 V (AC)	9 Amp.	1	60 Hz	12.5	21-1/2	7-5/16

6" & 8" Gear-Driven "Mud Hog" Sanders

- Powerful and lightweight.
- 900 RPM motor produces excellent low speed torque.
- Adjustable speed control. Soft grip housing insulates from cold.
- Our best PSA urethane, weight-mated sanding pad included for optimum performance.
- Hook pads available on page 56.

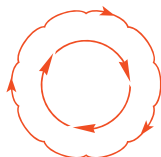

Unique cutting action is specific to "Mud Hogs" for quick and efficient filler removal.



Non-Vacuum

Model 10760

6" Diameter

- Includes 57762 PSA Pad.

Model 10763

8" Diameter

- Includes 56234 PSA Pad.



Model 10763

Central Vacuum-Ready

- Combination lip-seal overskirt allows enhanced vacuum capability and greater workpiece visibility.
- Dust is drawn away from air motor (reducing contamination) for a smoother, easier path of extraction.
- Anti-clog design is advantageous when sanding damp filler material.

Model 10761

6" Diameter

- Includes 57763 PSA Pad.
- 1-1/4" dia. vacuum port.

Model 10764

8" Diameter

- Includes 56235 PSA Pad.
- 2" dia. vacuum port.



Model 10764

**SEE PAGE 56 FOR
ORANGE SANDING PADS!**

Model Number	Motor hp	Motor RPM	Pad Dia. Inch	Maximum Air Flow CFM/SCFM	Hose I.D. Size Inch	Air Inlet Thread	Weight Pound	Length Inch	Height Inch
10760	.45	900	6	3/23	1/4	1/4" NPT	3.6	11-1/2	5-5/8
10761	.45	900	6	3/23	1/4	1/4" NPT	3.8	11-1/2	5-5/8
10763	.45	900	8	3/23	1/4	1/4" NPT	3.9	12-1/2	5-9/16
10764	.45	900	8	3/23	1/4	1/4" NPT	4.3	12-1/2	5-9/16

Additional Specifications: Air Pressure 90 PSIG

11" Gear-Driven "Mud Hog" Sanders

- Excellent torque; levels filler with ease and efficiency.
- 950 RPM. Excellent size-to-weight ratio.
- Great for truck and bus work.
- Composite handle with soft grip housing for comfort.
- Easy adjust speed control.
- Largest sander Dynabrade offers!

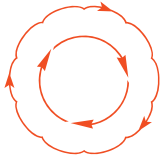

Unique cutting action is specific to "Mud Hogs" for quick and efficient filler removal.



Non-Vacuum

Model 58040

- Includes 56231 Hook-Face Sanding Pad.



Vacuum-Ready

Model 58041

- For use with "O" style abrasive discs, which allow dust to be drawn up through pad holes.
- Vacuum shroud has 1-1/4" diameter port, for connection to external vacuum system.
- Includes 56231 Hook-Face Sanding Pad.
- Conversion Pad available on page 56.



**SEE PAGE 56 FOR
11" SANDING PADS!**

Model Number	Motor hp	Motor RPM	Pad Dia. Inch	Maximum Air Flow CFM/SCFM	Hose I.D. Size Inch	Air Inlet Thread	Air Pressure PSIG	Weight Pound	Length Inch	Height Inch
58040	.45	950	11	3/23	1/4	1/4" NPT	90	5	14-3/32	5-10/16
58041	.45	950	11	3/23	1/4	1/4" NPT	90	5.5	14-3/32	5-10/16

DynaLocke® Dual Action Sander

Unique Disc Sander and Random Orbital Sander in one!

- Fast and Powerful
- Versatile
- Lightweight
- Soft grip housing insulates operator's hand from cold.
- Adjustable speed control; rear exhaust.
- All models include our best urethane hook-face sanding pad with common 5/16"-24 male thread.

Disc Sander OR 3/16" Random Orbital

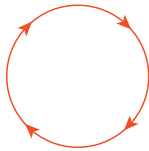

ROTARY ORBIT Strip, level and grind to bare metal!

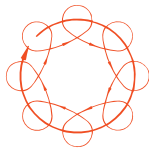

3/16" ORBIT Featheredge and finesse body panels!

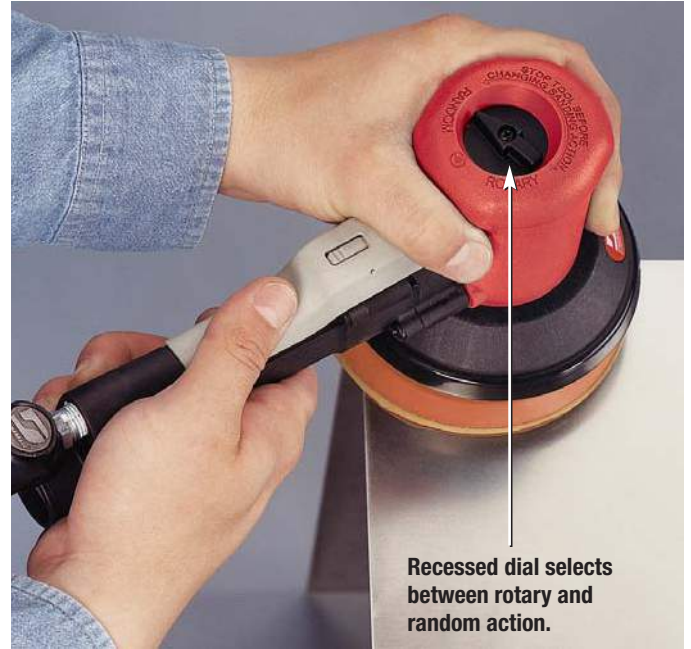

Recessed dial selects between rotary and random action.

**Amazing! Two Tools In One!
Performs Like No Other Sander!**

Non-Vacuum

Model 10770

3" Diameter

- Includes 56087 Pad.

Model 10780

3-1/2" Diameter

- Includes 54313 Pad.

Model 10750

5" Diameter

- Includes 54325 Pad.

Model 10754

6" Diameter

- Includes 54327 Pad.



Self-Generated Vacuum

- For connection to shop vac or central vacuum systems.
- Designed to vacuum in random orbital mode only.

Model 10771

3" Diameter

- Includes 56087 Pad.

Model 10781

3-1/2" Diameter

- Includes 54313 Pad.

Model 10752

5" Diameter

- Includes 54326 Pad.

Model 10756

6" Diameter

- Includes 54328 Pad.



Self-Generated Vacuum Model 10756

1-1/4" Dia. Vac Port

50617 Dust Collection System available. See page 53.

Model Description	Motor hp	Motor RPM	Air Flow Rate CFM/SCFM	Air Inlet Thread	Hose Size	Air Pressure PSIG	Weight Pound	Length Inch	Height Inch
3" Models	.45	12,000	3/23	1/4" NPT	1/4"	90	2.35	10-5/16	5-3/8
3-1/2" Models	.45	12,000	3/23	1/4" NPT	1/4"	90	2.35	10-5/16	5-3/8
5" Models	.45	12,000	3/23	1/4" NPT	1/4"	90	2.6	11-1/16	5-1/8
6" Models	.45	12,000	3/23	1/4" NPT	1/4"	90	2.7	11-1/2	5-1/8

Dry Dynabug® "Model T" Sander

- The lightest tool we offer – weighs only 1 pound!
- Great finishing tool; use for color sanding.
- Base plate is Hook-Face to accept interface pads.
- Adjustable speed control, runs up to 20,000 RPM.
- Uses reattachable and PSA abrasive sheets and discs.
- Never needs air tool oil.
- All models on this page include 3 ft. flexible air hose.

Up to **3/16" ORBITAL ACTION** – the faster the sander runs, the more aggressive the cutting action.



5" and 6" Diameter Round Models

Model 10475

5" Diameter

- Includes 56249 PSA Pad.

Model 10481

6" Diameter

- Includes 56269 PSA Pad.

Model 10477

5" Diameter

- Includes 56248 Hook-Face Pad.

Model 10483

6" Diameter

- Includes 56268 Hook-Face Pad.

4" x 4-1/4" Rectangular Models

- Use 4-1/2" x 4-1/4" paper for hook or PSA pads.
- Clips are good for 9" x 11" sheet paper, cut in four, or 6" disc will fit.

Model 10470

- With clips, includes 57999 PSA Pad.

Model 10479

- Without clips, includes 56244 PSA Pad.

Model 10472

- Without clips, includes 57998 Hook-Face Pad.

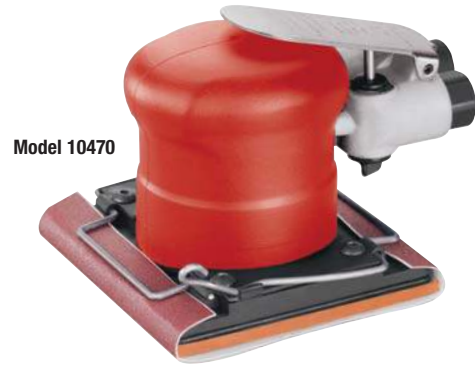

Central Vacuum Models

- Ready for hook-up to central vac system or our portable vacuum systems. Both models have 1" diameter exhaust port for vacuum hose hook-up.

Model 10485

- Includes 56286 PSA Vacuum Pad.

Model 10487

- Includes 56285 Hook-Face Vacuum Pad.



Hook-face base plate included on all models.

Model Number	Motor RPM	Orbit Dia. Inch	Sound Level	Air Flow Rate CFM/SCFM	Air Inlet Thread	Hose Size	Air Pressure PSIG	Weight Pound	Length Inch	Height Inch
All Models	20,000 max.	3/16"	83 max. dB(A)	1/9	1/4" NPT	1/4"	90	1.0	5	3

Wet Dynabug® "Model T" Sander

Self-siphoning. Includes 20 ft. of water hose, siphon-weight with replaceable water filter and foam interface pad.

- Ultra-lightweight, just over 1 lb!
- Stainless steel components never rust.
- 20,000 RPM tool never needs oil!
- Easy-adjust water valve with on/off and fast/slow selection.
- Fast, smooth and uniform surface preparation; reduced labor time.
- Our unique water feed "through-the-pad" design allows use of standard round wet paper with holes. No special sand paper or hole punch needed!
- Up to 3/16" diameter orbital action with adjustable speed control.

Model 10288

5" Diameter

- Includes standard 58086 Hook-Face Pad and soft 5" 53978 Interface Pad.

Model 10289

6" Diameter

- Includes standard 58093 Hook-Face Pad and soft 6" 53980 Interface Pad.

Available Interface Pads for Contours

- Soft foam increases conformability, allowing operator to easily follow contours. Converts standard pad into a fine finishing and finessing pad!
- Attaches between sanding pad and hook 'n loop abrasive. Easily contours to most surfaces.

Part No.	Description	Density
56245	4-1/4" x 4-1/2" Vinyl-Face Sponge Pad	1/2" Thick, Soft
57996	4-1/4" x 4-1/2" Hook-Face Sponge Pad	1/2" Thick, Soft
56246	5" Round Vinyl-Face Sponge Pad	1/4" Thick, Soft
56247	5" Round Hook-Face Sponge Pad	1/2" Thick, Soft
56287	6" Round Vinyl-Face Sponge Pad	1/4" Thick, Medium
56288	6" Round Hook-Face Sponge Pad	1/4" Thick, Soft

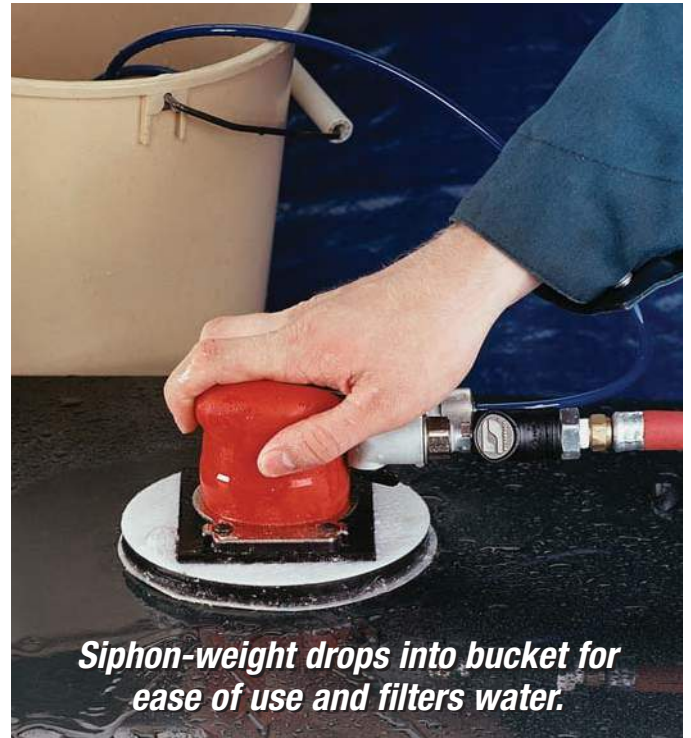

Siphon-weight drops into bucket for ease of use and filters water.



Double-sided hook-face interface pad attaches between sanding pad and hook-face abrasive.

Optional Portable Wet Tank

Part No. 96575

- Two gallon capacity. Makes wet sanders self-sufficient.
- Hand pump manually pressurizes container (50 PSI max.).



Optional Faucet/Garden Hose Connection

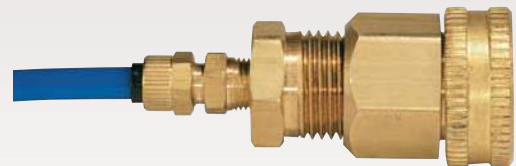

Model Description	Motor RPM	Orbit Dia. Inch	Sound Level	Air Flow Rate CFM/SCFM	Air Inlet Thread	Hose Size	Air Pressure PSIG	Weight Pound	Length Inch	Height Inch
All Models	20,000 max.	3/16" max.	72 dB(A)	1/9	1/4" NPT	1/4"	90	1.2	5	3

Wet Random Orbital Sanders

- Quickly remove runs, sags, orange peel, dust nibs and other imperfections.
- Achieve a uniform and consistent finish faster and easier than before.
- Saves time and labor; increases production.
- Each model comes complete with air and water connections.
- 10,000 RPM air motor with adjustable speed control.
- Overskirt shroud is standard on all machines to control water splash.
- "Short-Nap" Hook-Face Sanding Pad included (1/2" thick).
- Hook-up to garden hose or optional 96575 Portable Wet Tank (shown below).
- Interface Pads available on page 59.



TWO-WAY WATER VALVE
Push the button as desired, or... lock the valve in place for desired water flow rate!

Wet Random Orbital Sander Models

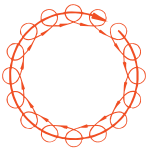

TIGHT 3/32" ORBIT

- Provides the very best finish. Excellent finesse sander.

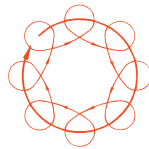

3/16" ORBIT

- Ideal for general wet sanding and production-type jobs.

Tool Size	3/32" Orbit Models
3-1/2"	10351
5"	10353
6"	10354

Tool Size	3/16" Orbit Models
3-1/2"	10341
5"	10343
6"	10345

Included Air and Water Connections



Optional Portable Wet Tank

Part No. 96575

- Eliminates need for garden hose.
- Two gallon capacity.
- Hand pump manually pressurizes container (50 PSI max.).
- Bring water source to the work. No need to trip over water hoses on the busy shop floor.



Model Number	Motor hp	Motor RPM	Pad Dia. Inch	Sound Level	Air Flow Rate CFM/SCFM	Air Inlet Thread	Air Pressure PSIG	Weight Pound	Length Inch	Height Inch
10341/10351	.24	10,000	3-1/2	76 dB(A)	2/16	1/4" NPT	90	2.1	6	3-3/4
10343/10353	.24	10,000	5	77 dB(A)	2/16	1/4" NPT	90	2.1	6-1/2	3-5/8
10345/10354	.24	10,000	6	74 dB(A)	2/16	1/4" NPT	90	2.2	7	3-1/2

Wet Dynafine® Detail Sander

Model 10880

- Tiny 1/32" diameter orbital action for a superior finish.
- Hooks directly up to hose or optional wet tank.
- Perfect for quick spot repair and efficient removal of dust nibs on clear coat paint systems. With built-in misting system, operator can spray the work surface then remove the imperfection – all within seconds!
- Powerful .15 hp air motor, 13,000 RPM.
- Accepts 2" and 3" diameter sanding pads (PSA or hook-face) for corresponding abrasive discs. One PSA pad of each diameter is included with tool.
- Misting System helps flush abrasive to achieve a consistent, repeatable finish.
- Ergonomic 7° offset design for greater operator comfort and control.
- Rear exhaust directs air away from work piece; reduces sound levels.
- Insulated tool housing reduces cold air transmission to the operator.
- Includes 10 ft. water line with Male Quick Disconnect and faucet/garden hose connection (see below).
- Optional hook-face pads available on page 57.



*Features Our
"Finger Touch"
Misting System
for Total Water
Control!*



Includes Faucet/Garden Hose Connection

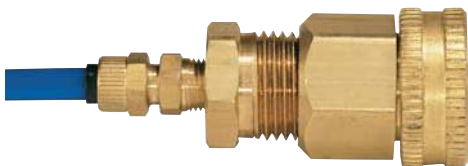

Optional Portable Wet Tank

Part No. 96575

- Two gallon capacity. Makes wet sanders self-sufficient; no need for a garden hose.
- Translucent tank allows easy viewing of liquid level.
- Hand pump manually pressurizes container (50 PSI maximum pressure).



Model Number	Motor hp	Motor RPM	Sound Level	Air Flow Rate CFM/SCFM	Hose Size	Air Inlet Thread	Weight Pound	Length Inch	Height Inch
10880	.15	13,000	65 dB(A)	3/20	1/4"	1/4" NPT	1.75	9	3-3/4

Dynabug® Orbital "Jitterbug" Sander

- Great for blocking on flat surfaces. Smooth and quiet operation.
- 10,000 RPM, rear exhaust, adjustable speed control.
- Spring clips hold sandpaper securely.

Non-Vacuum

- 3-2/3" x 7" abrasive sheet fits pad area. Use 3-2/3" x 9" paper when securing the paper to the built-in clips.
- Includes premium 57850 PSA Pad.

Model 10170 3/32" Orbit **Model 57800** 3/16" Orbit



Central Vacuum

- Includes premium 57855 PSA Pad.
- Ready to connect to your central vacuum system or shop vacuum.

Model 10174 3/32" Orbit **Model 57804** 3/16" Orbit



Optional Punch Plate

Part No. 57476

- 3-2/3" x 7" Punch Plate for converting non-vac to vacuum paper.



NOTE: Self-Generated Vacuum Model (57801), 3/16" orbit only, also available.

Model Number	Motor hp	Motor RPM	Air Flow Rate CFM/SCFM	Hose Size	Air Inlet Thread	Air Pressure PSIG	Weight Pound	Length Inch	Height Inch
10170 / 10174	.25	10,000	2/16	1/4"	1/4" NPT	90	2.75	7-1/4	4-1/4
57800 / 57804	.24	8,000	2/16	1/4"	1/4" NPT	90	2.8	7-1/4	4-1/4

Dynabug® II Orbital Finishing Sander

- A small tool that's big on performance. 3/32" orbit with 10,000 RPM.
- Premium urethane hook-face pad included on all models.
- Designed for efficient finishing of composites, fiberglass, painted and metal surfaces.
- Lightweight and compact. Rectangular pad sands deep into corners where orbitals can't touch.
- Central-vacuum models have 1" vacuum port. Ready for external vacuum source.
- Replacement and PSA pads on page 58.

Non-Vacuum

Model 10280

- 3" x 4-1/4" pad.

Model 10283

- 3-1/4" x 5" pad.

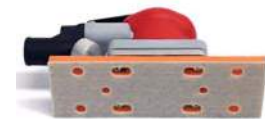

Loop Face Pad

Part No. 56324

- Compatible with reverse hook 'n loop abrasives.

Central Vacuum

Model 10282

- 3" x 4-1/4" pad.

Model 10285

- 3-1/4" x 5" pad.



Model Number	Motor hp	Motor RPM	Air Flow Rate CFM/SCFM	Hose I.D. Size Inch	Air Inlet Thread	Air Pressure PSIG	Weight Pound	Length Inch	Height Inch
10282/10285	.15	10,000	1.8/13	1/4"	1/4" NPT	90	1.6	5-3/4	3-1/2
10280/10283	.15	10,000	1.8/13	1/4"	1/4" NPT	90	1.7	8-1/2	3-1/2

Dynaline 8" Board Sander

- Ultra-smooth in-line sanding action.
- Tool's precision gear-set provides unstoppable sanding power with control.
- 2,400 strokes per minute; 3/8" long sanding stroke is very consistent.
- Ideal for areas where a conventional long board sander is too big.
- Adjustable speed control. Rear exhaust.
- Not a "jitterbug" type sander.
- Piston driven sanders don't even come close to this tool's performance.
- Contoured specialty pads available on page 57.



On Non-Vac Model, Pad Can Be Rotated 360° and Set at Any Comfortable Position. No Other Tool Like It!

Non-Vacuum

Model 10400

- Includes 57454 PSA Pad for 2-3/4" wide x 8" abrasive paper.
- 3-2/3" x 7" and 2-3/4" x 11" pads are also available.
- Reattachable abrasive sheets may be mounted with optional "short-nap" hook-face pad.

Central Vacuum

Model 10404

- Includes 57455 PSA Sanding Pad. Ready to connect to your central vacuum system or shop vac.
- Mount 2-3/4" x 8" vacuum paper (6-hole).
- Optional 57474 Punch Plate for 2-3/4" x 8" pad and 57476 Punch Plate for 3-2/3" x 7" pad are available to convert to vacuum paper.



360° Pad Rotation!
Set Pad to Desired Position!

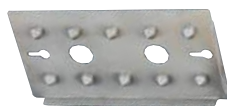

Optional Punch Plate

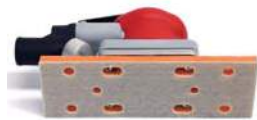

Loop Face Pad

Part No. 56324

- Compatible with reverse hook 'n loop abrasives.



Model 10404

Model Number	Motor hp	Stroke Inch	Strokes per Minute	Sound Level	Air Flow Rate CFM/SCFM	Air Inlet Thread	Hose Size	Air Pressure PSIG	Weight Pound	Length Inch	Height Inch
All Models	.25	3/8	2,400	85 dB(A)	3/18	1/4" NPT	1/4"	90	2.6	7	3-3/4

Dynaline 11" Board Sander

- Ultra-smooth in-line sanding action.
- Tool's precision gear-set provides unstoppable sanding power with control.
- Available non-vacuum only.
- Insulated longer handle for added control and stability.
- 2,400 strokes per minute; 3/8" long sanding stroke is very consistent.
- Not a "jitterbug" type sander.
- Piston-driven sanders don't even come close to this tool's performance.



Model 10540

- Includes 2-3/4" wide x 11" long, premium urethane PSA sanding pad with clips (57512).
- For use with hook-face, PSA coated abrasives.
- 3-2/3" x 7" and 2-3/4" x 8" pads may also be used – see page 57.



10541 Kit

- Includes 10540 tool with 2-3/4" wide x 11" long, premium urethane PSA pad with clips (57512), and hook-face pad (57513) with sample abrasives.

Model Number	Motor hp	Stroke Inch	Strokes per Minute	Sound Level	Air Flow Rate CFM/SCFM	Air Inlet Thread	Hose Size	Air Pressure PSIG	Weight Pound	Length Inch	Height Inch
10540	.25	3/8	2,400	85 dB(A)	3/18	1/4" NPT	1/4"	90	3.1	11	3-3/4

Dynorbital® Supreme Scrubber

Model 10350

- Excellent tool for detail shops! Use with shampoo or cleaner to power out dirt and stains.
- Random orbital 10,000 RPM action allows brush bristles to loosen trapped dirt particles. Adjustable speed control.
- Helps to restore matted carpet fibers. Rejuvenate worn and dirty interiors!
- Random orbital "agitation" action makes the difference in deep cleaning carpets, floor mats, seats (cloth, leather, vinyl), trunk areas, tires and convertible tops.
- Tool includes 54309 Brush Holder, 90840 Short-Nap 3-1/2" Cleaning Brush (1/2" thick) and 90841 Long-Nap 3-1/2" Cleaning Brush (7/8" thick).



Model Number	Motor hp	Motor RPM	Sound Level	Spindle Thread	Air Flow Rate CFM/SCFM	Air Inlet Thread	Hose Size	Air Pressure PSIG	Weight Pound	Length Inch	Height Inch
10350	.24	10,000	77 dB(A)	5/16"-24 Female	2/16	1/4" NPT	3/8"	90	2.2	5-3/4	3-1/2

Palm-Style Mini-Dynorbital® Buffers

3" Diameter Buffer

Model 10390

- Includes 50125 Hook-Face 3" Back-Up Pad, sample 90027 Terry Cloth and 90028 Wool Pads.
- Compact and powerful.
- 2,400 RPM geared, rotary motor with rear exhaust and speed control.
- Full-size buffers are too big for small jobs and parts.
- Buffing pads selection on page 44.



5" Diameter Buffer

Model 10398

- Includes 50146 Hook-Face Back-Up Pad and sample 90040 5" Foam Polishing Pad.

3" Three-In-One Versatility Kit

10393

- **3" Buffer, 3" Rotary Sander, 1-1/4" Dust Nib Remover!**
- Includes all you need for quick, simple spot repair on painted surfaces. Remove dust nibs and scratches on base coat/clear coat!
- Basic tool – 2,400 RPM.
- 50125 Hook-Face Backing Pad (3" diameter).
- 54018 "Medium" 1-1/4" Vinyl-Face Sanding Pad.
- 54486 "Soft" Vinyl-Face Pad (3-1/2" diameter).
- 54476 Mini-Orbital Head with 1/4"-20 female thread to fit tool spindle, 1/4"-20 male thread to mate with sanding pad.
- Sample 9-micron (1,000 grit) micro-finishing film discs (1-1/4" diameter); 92096 Sample Abrasive Pack (3-1/2" 100 grit PSA sanding discs).
- 90027 Terry Cloth Bonnet (3" diameter); 90028 Wool Bonnet (3" diameter); 90038 Foam Pad (3" diameter).
- 95723 Dynabrade Finesse Creme (4 oz.); 95727 Dynabrade Glaze (4 oz.); Wrenches for pad changes.



CHECK OUT OUR BUFFING PAD SELECTION ON PAGE 44.

Spot Repair Made Easy!

Model Number	Motor RPM	Sound Level	Spindle Thread	Air Flow Rate CFM/SCFM	Air Inlet Thread	Hose Size	Air Pressure PSIG	Weight Pound	Length Inch	Height Inch
All Models	2,400	82 dB(A)	1/4"-20 male	3/18	1/4" NPT	1/4"	90	1.7	5	3-1/4

7" - 8" Electric Rotary Buffer

Model 51580

- Variable speed trigger with adjustable 0-3,000 RPM roller dial for optimum performance and control. Desired RPM can be locked with speed-lock button.
- Top-quality brushes last longer, and are externally accessible for increased productivity.
- Versatile rubberized side handle mounts in three positions, for ultimate versatility.
- 11-amp motor for power!
- Long 8-foot electric cord is made of oil-resistant rubber, and stays flexible when cold.





 C US
120 V (AC)

3 Positions To Choose From!

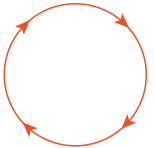

Handle Rotates 180° Here

Model 51580



ROTARY ORBIT For cutting, polishing and buffing using compounds.

Shown with optional 50853 Backing Pad, and optional 90082 Polishing Pad.



One-touch switch easily allows new trigger handle to rotate 180° into any position.

Note: Back-up pads and polishing pads are sold separately.

Model Number	Motor RPM	Maximum Watts Out	Voltage	Current Amps	Phase	Frequency	Spindle Thread	Weight Lb.	Length Inch	Height Inch
51580	0-3,000	1305	120 V (AC)	11	1	60 Hz	5/8"-11	7.8	17	5-1/4

Random Orbital Buffers

NO MORE SWIRLS!

NEW!

Electric Powered

Model 51584

- Same great features as Rotary Model 51580, with our exclusive "Twist Handle" capability.
- Works without leaving haze, halo or swirl marks... a must for dark finishes!
- Unique random orbit provides outstanding performance over conventional rotary buffers.
- Prevents "burn through" on edges of clear coat finishes!
- Includes comfort grip handle that fits on either side or top of tool.
- Includes 50855 Hook-Face Backup Pad and 90082 Wool Buff, 7" in diameter.



120 V (AC)

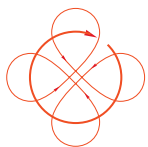

Large 3/4" diameter random orbital action makes the difference! No heat build-up, surface stays cool.

Model Number	Motor RPM	Voltage	Current	Phase	Frequency	Weight Pound	Length Inch	Height Inch
51584	0-3,000	120 V (AC)	11	1	60 Hz	7.8	17	5-1/4

Air Powered

Model 10786

- .7 hp motor, 2,500 RPM. Insulated housing for comfort.
- Random Action prevents swirls and helps achieve a beautiful finish!
- Includes comfort grip handle that fits on top or either side of tool.
- Helps prevent burn-through on edges of clear coat finishes.
- Includes 50855 Hook-Face Backup Pad, 7" in diameter.
- Accepts optional buffing pads 7" to 8" in diameter.



Air Model 10786 shown with optional Foam Pad

61374 Random Orbital Conversion Head Kit also available separately – see page 43.



Model Number	Motor hp	Motor RPM	Maximum Air Flow CFM/SCFM	Hose I.D. Size Inch	Air Inlet Thread	Air Pressure PSIG	Weight Pound	Length Inch	Height Inch
10786	.7	2,500	3/27	3/8	1/4" NPT	90	6.3	14-3/8	5-3/8

"Two-Step" Spot Repair System

- Remove minor surface defects that protrude through clear coat.
- Achieve OEM results in your shop.
- Eliminates swirl marks, "hazing" and sanding scratches common with other methods.

Step 1

Using Model 57502 Mini-Random Orbital Sander, place the sanding disc slightly off-center of the defect with slight pressure on the pad. Throttle the tool on, and sand in a random pattern for 2-5 seconds. Water must be used for sanding lubrication. Apply water directly to the disc. Keep the sanding pad flat while sanding. Throttle the tool off and remove from surface. Let the tool and the abrasive do the work. Keep the area sanded as small as possible. Wipe the area clean when finished with a clean non-scratching cloth.



Mini-Random Orbital Sander

Model 57502

- 7,500 RPM. Includes 54035 Sanding Head (accepts 3" and smaller dia. sanding pads with male locking-type threads).

Step 2

Apply a small drop of polishing compound. Using Dynabuffer (3" or 5" diameter models), use the buff to spread compound evenly over spot. (Note: precondition pad by evenly spreading compound directly on pad.) Place the buff on the sanding area. Apply approx. 10 lbs. of force to the work surface, throttle the tool on, adjust force as required, and buff in a random pattern for 5-10 seconds. Keep buff flat or slightly tipped forward. Feather the area with lighter pressure for two seconds. Wipe the area clean with non-scratching cloth and inspect. If scratches are still visible, re-polish as needed.

Dynabuffer

- Features a 14 mm diameter offset orbit.
- Tools run at 10,000 RPM free speed.
- Patented balancer compensates for vibration when running under load, resulting in a smooth operating performance (Patent 6,206,771).
- Rear exhaust muffler design reduces sound levels.

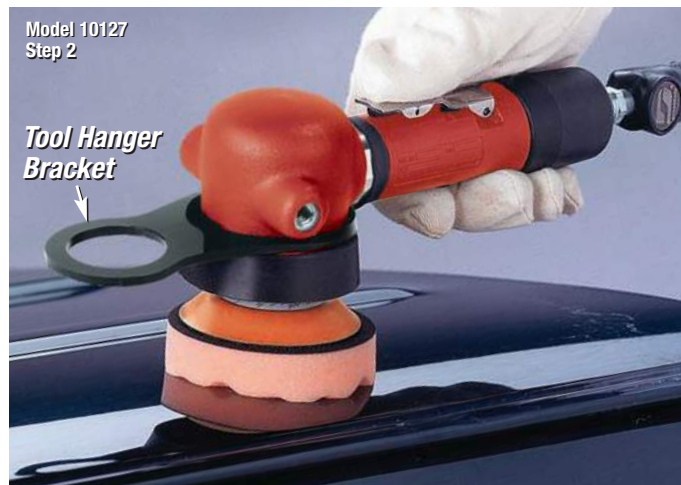

Model 10127

3" Diameter

- Includes 56142 Backup Pad and hanger bracket.
- 90070 Foam Buff must be ordered separately.
- Optional 53163 Side Handle available.

Model 10745 (Not Shown)

5" Diameter

- 90063 Foam Buff and 56195 Backup Pad must be ordered separately.

Foam Buff Pads

90070

3-1/4" Diameter

90063

5" Diameter

90071

95 mm Diameter



Model Number	Motor hp	Motor RPM	Sound Level	Maximum Air Flow CFM/SCFM	Hose I.D. Size Inch	Air Pressure PSIG	Tool Thread	Weight Pound	Length Inch	Height Inch
10127	.16	7,000	74 dB(A)	3/20	3/8	90	5/16"-24 Female	2.0	8-1/4	3-1/8
10745	.36	10,000	79 dB(A)	3/20	3/8	90	5/16"-24 Female	2.7	10-1/4	4-1/2
57502	.05	7,500	70 dB(A)	1/6	1/4	90	1/4"-20 Male	1.7	5	3-5/8

Additional Specifications: Air Inlet Thread 1/4" NPT

Dynafine® Detail Sander

- Amazingly smooth and very quiet. Lightweight... only 1.6 lbs!
- Uses reattachable and PSA mounted, coated non-woven nylon and sponge abrasives.
- 15,000 RPM rear exhaust air motor. Features 1/32" dia. orbital action for a superior finish.
- Insulated composite handle is offset for operator comfort and may be adjusted for left or right-handed users.
- Non-marring composite Dynaswivel® flow-control speed regulator is included.
- **Many versatile applications:**
 - Composite bumper repair; bevel edges of cut-outs; restoration work.
 - Grooves, contours, window sills, doorjambs, spoilers and more!



Non-Vacuum

Model 10800

- Includes tear-drop hook-face pads.

10810 Versatility Kit

- Includes tool with hook-face and PSA pads and an assortment of coated hook-face, non-woven nylon and sponge abrasives.



Self-Generated Vacuum

Model 50815

- Utilizes tool's exhaust to create strong vacuum suction.
- 1" diameter vacuum port ready for connection to optional portable self-contained dust collection system (such as 50617 Flex-Hose System, sold separately).

Central Vacuum

Model 50817

- 1-1/4" diameter vacuum port ready for connection to external or central vacuum system.
- Includes Conductive Hose and Cuffs to shield operator from electrostatic discharge (ESD).



Dynafine® Finger Sander

Model 10820

- Tiny 1/32" diameter orbital action for fine finishes. Eliminate tedious hand sanding.
- Lightweight... only 1.6 lbs. Excellent for use on edges, corners and hard-to-reach areas. Eliminate wrapping sand paper around paint sticks, let the tool do the work.
- Includes tool with 3/8" wide sanding arm, sample platen pads and sample abrasive strips (120, 180 and 240 grit).



10821 Deluxe Versatility Kit

- 10820 tool, 57932 and 57931 3/4" Sanding Arms.
- Hook-face and PSA pads.
- 3/8" and 3/4" abrasive strip assortment (120, 180, 240 grits).
- Coated hook-face, non-woven nylon and sponge abrasives.



Model Number	Motor hp	Motor RPM	Sound Level	Air Flow Rate CFM/SCFM	Hose Size	Air Pressure PSIG	Weight Pound	Length Inch	Height Inch
All Models	.16	15,000	65 dB(A)	2/19	3/8"	90	1.6	9	3-3/4

Heavy Duty Pneumatic Tools

4-1/2" - 5" Dia. Pistol Grip Disc Sander

Model 50321 11,000 RPM

- 5/8"-11 male spindle, .7 hp, rear exhaust.
- Includes 50263 Disc Mount Assembly.
- Ideal for use with abrasive impregnated non-woven nylon discs.
- Removable side handle.



Model 50321

4" Diameter Pistol Grip Disc Sander

Model 50324 11,000 RPM

- 3/8"-24 male spindle, .7 hp, rear exhaust.
- Ideally speed-mated to 4" diameter locking-type discs.
- Includes 50192 locking-type pad. Removable side handle.



Model 50324

3" Dia. Gearless Cut-Off Wheel Tool

Model 52420 Front Exhaust

- .5 hp, 20,000 RPM, right angle, safety-lock throttle lever.
- Ideal for cutting metal, fiberglass and plastic.
- 7° lightweight composite offset handle for greater operator comfort and control.



Model 52420

7° Offset, 1/4" Collet Die Grinders

- .4 hp, gearless, rear exhaust. Great for left or right hand usage.
- Lightweight, insulated, ergonomic handle.
- Adjustable collar for comfort and control.

Model 52335 25,000 RPM

Model 52337 30,000 RPM



Model 52335

2" Dia., .4 hp, 7° Offset Disc Sander

Model 52503 25,000 RPM

- Lightweight, composite, ergonomic handle.
- Includes locking-type pad for 2" diameter locking-type discs.
- Has 1/4"-20 male spindle, rear exhaust.



Model 52503

.4 hp, 1/4" Chuck Drill

Model 52836 20,000 RPM

- Air-powered in NEW pistol grip design!
- Powerful high-torque air motor is ideal for countless applications.
- Finger platform on both sides of tool allows increased stability and comfort.
- Ergonomic, compact design for enhanced comfort with textured tactile grip.



Model 52836

Convenient Finger Platform on both sides of tool

Model Number	Motor hp	Motor RPM	Sound Level	Spindle Thread	Air Flow Rate CFM/SCFM	Air Inlet Thread	Hose Size	Air Pressure PSIG	Weight Pound	Length Inch	Height Inch
50321/50324	.7	11,000	79 dB(A)	3/8"-24 male	4/32	1/4" NPT	3/8"	90	2.2	6-5/8	5-5/8
52335	.4	25,000	76 dB(A)	3/8"-24 male	3/18	1/4" NPT	1/4"	90	1.0	6	3-3/4
52337	.4	30,000	79 dB(A)	3/8"-24 male	3/21	1/4" NPT	1/4"	90	1.0	6	3-3/4
52420	.5	20,000	85 dB(A)	3/8"-24 male	4/28	1/4" NPT	3/8"	90	2.2	6	5-1/2
52503	.4	25,000	87 dB(A)	1/4"-20 male	3/20	1/4" NPT	1/4"	90	1.3	9	3-3/4
52836	.4	20,000	78 dB(A)	3/8"-24 male	3/22	1/4" NPT	1/4"	90	1.8	5.9	5

Heavy Duty Mini-Dynaflex® II Belt Tool

Model 15003

- Grind, sand, and deburr in those tight spots!
- Tool includes 15026 Contact Arm for 1/2" wide x 12" long abrasive belts; other arms available for 1/8" and 1/4" wide belts.
- Lightweight, ergonomic tool. Rear exhaust.
- Light grinding and deburring applications. Great for engine porting.
- Accepts coated and abrasive impregnated non-woven nylon belts.
- Screw-off belt guard for easy abrasive change.
- Multi-position grinding head pivots 180°.



Model 15003

15006 Versatility Kit

- Belt Sander and Die Grinder in one tool!
- Includes 15003 tool with unique drive wheel which accepts included threaded collet for easy conversion to a die grinder.
- 15026 Contact Arm mounted on tool. Two additional arms: 15028 and 15030.
- Carry case and sample 1/2" wide coated abrasive and non-woven nylon belts.

Model 15006



Model Number	Motor hp	Motor RPM	Sound Level	Abrasive Belt Size Inch	Maximum Air Flow CFM/SCFM	Maximum SFCM	Weight Pound	Length Inch	Height Inch
15003	.4	25,000	80 dB(A)	1/8-1/2 W x 12 L	3/20	4,890	1.8	11-3/4	3-1/2

Additional Specifications: Air Inlet Thread 1/4" NPT • Hose I.D. Size 1/4" • Air Pressure 90 PSIG

Heavy Duty Buffers

3" Right Angle Buffers

- Includes 50126 Hook-Face Pad, 90027 Terry Cloth Bonnet and 90028 Wool Buffing Bonnet. Hook-face attachment makes changing pads quick and easy.
- Conventional rotary action. 7° offset handle, .4 Hp motor.

Model 51400
3,200 RPM

Model 51401
5,000 RPM



90027 Terry Pad

90028 Wool Pad Shown on 51400 Tool

5" Right Angle Buffer

Model 51430
3,200 RPM

- Includes 50147 Hook-Face Pad. Hook-face attachment makes changing pads quick and easy. Also includes 90040 Foam "Flat Face" Buffing Pad.
- 7° offset handle, .4 hp motor.



51430 Tool shown with optional 13141 Handle Assembly

Model Number	Motor hp	Motor RPM	Sound Level	Spindle Thread	Air Flow Rate CFM/SCFM	Air Inlet Thread	Hose Size	Air Pressure PSIG	Weight Pound	Length Inch	Height Inch
51400/51401	.4	3,200/5,000	82 dB(A)	3/8" - 24 male	3/24	1/4" NPT	1/4"	90	1.7	8-3/4	4-1/4
51430	.4	3,200	82 dB(A)	3/8" - 24 male	3/24	1/4" NPT	1/4"	90	2.4	9-3/4	4-1/2

Electric Tools

Electric Dynafile® II Abrasive Belt Tool

Model 40610

- Electric Dynafile® II runs coated abrasive and non-woven nylon belts, and is ideal for countless applications on metal, plastic, fiberglass, solid surface, stone, glass, etc.
- Includes 11203 Contact Arm, for abrasive belts 1/2" wide by 18" long.
- Grind with contact wheel or platen pad. Finish and polish using slack of belt.
- Tool accepts over 20 interchangeable contact arms for use with belts 1/4" to 3/4" wide x 18" long.
- Comfortable switch with "lock on" feature.
- Easily accessible brushes for quick replacement.
- Sanding head pivots 360°, for working in previously inaccessible areas.
- Reversible side handle for operator comfort.
- Tool is double-insulated for safety, and includes electric cord, 8 feet in length.



Electric Dynafile® II Versatility Kit

Model 40611

- Includes 40610 Electric Dynafile® II with 11203 Contact Arm, and two additional arms (11202 and 11204). Also includes eight abrasive belts of various grits, and an assortment of platen pads. All items contained in a durable carrying case.

Model Number	Motor RPM	Maximum Watts Out	Abrasive Belt Size Inch (mm)	Voltage	Current Amps	Phase	Frequency	Weight Pound (kg)	Length Inch (mm)	Height Inch (mm)
40610	11,000	680	1/4-3/4 (6-19) W x 18-24 (457-610) L	120 V (AC)	6	1	60 Hz	5 (2.3)	19 (483)	5.5 (140)

Additional Specifications: Maximum 2,520 SFPM (768 SMPM)

Electric Depressed Center Wheel Grinder

Model 40260

- For 4-1/2" diameter grinding wheels and abrasive discs.
- 5/8"-11 spindle thread accepts optional Type 27 Depressed Center Wheels and Abrasive Flap Discs, 4-1/2" diameter with 7/8" center hole.
- Industrial-quality electric motor rated at 6 amps.
- Easily accessible brush holders allow quick brush replacement (recommended every 150 hours).
- Convenient spindle lock offers fast change of accessory.
- Locking power switch for extended use with less fatigue.
- Repositioning side handle for left or right hand operation.
- All ball-bearing and needle-bearing construction ensures longer tool durability.



Important: Always use required wheel guard. Never remove wheel guard from tool. Speed of tool must not exceed maximum operating speed of accessory. Never mount bonded grinding wheels. Always wear eye, face and body protection.

Model Number	Maximum Watts Out	Motor RPM	Voltage (AC)	Current Amps	Phase	Frequency	* Weight Pound	Length Inch	Height Inch
40260	680	11,000	120	6	1	60 Hz	4.6	12	4.25

*Weight includes flanges, side handle and wheel guard, with no wheel attached.

DynaPen Filer Kit

- Ideal for intricate deburring on delicate parts.
- Powers files at 14,000 strokes a minute, in short stroke length of .007" (.018 mm).
- Air line swivels 360° for great maneuverability, especially on contoured parts.
- One-touch on/off button, conveniently mounted to air line.
- Tool also accepts optional collet sizes of 1/16" (51780) and 3/32" (51674).

10844 Kit

- Includes 10832 DynaPen with 51673 Collet Insert (3 mm), 51659 Collet Insert (1/8"), 95731 Wrench, 90900 Straight File, 90901 Curved File and 90930 Half-Round File.

Model 10843

- Tool includes 51659 Collet Insert (1/8") only.



**ASK ABOUT
KITS WITH
CHISELS AND
SCRIBE POINTS!**



Model Number	Motor RPM	Stroke Length Inch	Maximum Air Flow SCFM	Air Pressure PSIG	Collet Size	Weight Pound	Length Inch	Diameter Inch	Hose Length Inch
10832	14,000	.007	7	90	3 mm	.57	4.25	.9	56

AutobradeRed® FOR THE VALUE-MINDED PRO

Auto File II Abrasive Belt Tool

Model 18100

3/4" Wide

- Includes 11206 Contact Arm for 3/4" x 18" long coated abrasive and non-woven nylon belts. 1/2" x 18" long belts also fit.
- Excellent multi-purpose tool for grinding sharp metal edges, rusted bolts, welds, etc. Works well on composites, blending, scuffing grooves and contours. Hundreds of uses in every shop!



Additional contact arms available – call for details.

Four-In-One Versatility Kit

18025

1/4" Die Grinder • 3" Cut-Off Tool
Belt Sander • 3" Disc Sander

- Quick and convenient, easy to change accessories. A must for all shops.
- Includes: 18100 basic tool, .5 hp gearless 20,000 RPM motor, front exhaust, 7° offset composite handle with safety-lock throttle; 50010 Collet; 50292 Cut-Off Guard; 50269 Flange; 51347 3" Backing Pad (3/8"-24); 15352 Drive Wheel; 40014 Belt Housing Assembly; 11206 Contact Arm Assembly; 94300 Dynaswivel®; wrenches for accessory changes; sample abrasive belt and 3" abrasive disc; deluxe storage/carrying case.



Model Number	Motor hp	Motor RPM	Sound Level	Maximum Air Flow CFM/SCFM	Air Inlet Thread	Hose Size Inch	Air Pressure PSIG	Weight Pound	Length Inch	Height Inch
18100	.5	20,000	79 dB(A)	3/22	1/4" NPT	3/8	90	2.8	15	5

AutobradeRed® FOR THE VALUE-MINDED PRO

RED-TRED® Eraser Disc Pistol Grip Tool

Model 18069 5/8"-11 Thread

- 2,500 RPM right angle tool includes 92295 RED-TRED® Eraser Disc Assembly.
- Efficiently remove graphics, decals, pinstriping and tape without harming the paint.
- Ergonomic pistol grip design enhances operator comfort.
- Tool is also ideal for running optional buffing accessories (see 18071 Kit).



Pistol Grip Buffer

Model 18068 3/8"-24 Thread

- Operates at 2,500 RPM, ideal for a variety of buffing applications.
- Includes 50126 Hook-Face Backing Pad, for accepting optional buffs and bonnets 3" in diameter (see Versatility Kit).
- Ergonomic pistol grip design enhances operator comfort.
- To run 92295 RED-TRED® Eraser Disc Assembly, order optional 55066 Adapter (converts 3/8"-24 spindle thread to 5/8"-11 thread).



Ideal for use with optional 90044 Foam Cutting Pad.

SEE RED-TRED® DISC ASSEMBLY ON PAGES 45 & 61!

Pistol Grip Eraser Disc/Buffing Versatility Kit

Model 18071

Includes:

- 18068 Pistol Grip Buffer with 50126 Hook-Face Backing Pad
- 92295 RED-TRED® Eraser Disc Assembly (5/8"-11 thread)
- 90027 Terry Cloth Pad and 90080 Sheepskin Pad
- 90038 Polishing Foam Pad and 90044 Foam Cutting Pad
- 55066 Spindle Thread Adapter (converts 3/8"-24 thread to 5/8"-11)
- 95281 Open-End Wrench (19 mm)



Model Number	Motor hp	Motor RPM	Pad Dia. Inch	Sound Level	Air Flow Rate CFM/SCFM	Spindle Thread	Air Inlet Thread	Weight Pound	Length Inch	Height Inch
18068	.18	2,500	3	80 dB(A)	23/651	3/8"-24	1/4" NPT	1.7	5	6-3/8
18069	.18	2,500	4	80 dB(A)	23/651	5/8"-11	1/4" NPT	2.5	5.3	7

RED-TRED® Eraser Disc Standard Duty Tool

Model 18067

- 2,400 RPM right angle tool includes 92295 RED-TRED® Eraser Disc.
- Compact, comfortable design easily reaches into tight areas.
- Rear exhaust tool is speed-mated for optimum performance.
- Offers greater visibility on work surface. Includes fully adjustable side handle.

Model 18067



RED-TRED® Eraser Disc Heavy-Duty Tool

Model 10789

- More powerful tool is ideal for aggressive applications.
- Right angle tool includes 92295 RED-TRED® Eraser Disc.
- 2,500 RPM with variable speed lever throttle.
- Comfortable side handle is adjustable for left or right hand use.

Model 10789



Model Number	Motor hp	Motor RPM	Pad Dia. Inch	Sound Level	Air Flow Rate CFM/SCFM	Spindle Thread	Air Inlet Thread	Weight Pound	Length Inch	Height Inch
18067	.4	2,400	4	82 dB(A)	3/28	5/8"-11	1/4" NPT	3	11-7/8	2-3/4
10789	.7	2,500	4	77 dB(A)	3/27	5/8"-11	1/4" NPT	5	12-1/2	4-1/4

DynaZip Surface Preparation Tool

- Excellent power and torque at 3,200 RPM for effectively removing seam sealer, rust proofing, chip guard, paint and surface rust in common and tight areas around vehicles.
- These spring steel wheels dramatically outperform conventional spiral-wound wire wheels without clogging.
- Quick and easy accessory change.
- Tool duplicates sand-blasting effect without surface fatigue and provides ultimate contour adaptation.
- Replacement hubs, wire and eraser wheels shown on page 45.



DynaZip Air Tool

Model 18255

- Includes: 3,200 RPM tool, multi-position handle with fully adjustable guard, 92245 3/4" Coarse Wire Wheel and 92284 3/4" Hub Assembly.

Model 18253

- 3,200 RPM Tool ONLY (no accessories included).

RED-TRED® DynaZip-Eraser Decal Removal Tool

Model 18258

- Superior performance versus conventional "solid" or "doughnut-type" wheel erasers with **NO PAINT DAMAGE!** Works great on metal surfaces; excellent for removing two-sided adhesive molding tape too.
- RED-TRED® wheel has serrations for improved cooling effect air flow. Also resists heat buildup and prevents "jumping" or vibrations.
- Includes 3,200 RPM tool with side handle, wheel guard and 92257 Decal Removal Wheel Assembly (which includes hub).



DynaZip Basic Kit

Model 18256

- 18255 Standard Tool
- 92252 1/2" Wheel Hub Assy.
- 92245 3/4" Coarse Wire Wheel
- 92284 Wheel Hub Assy.
- 92248 1/2" Coarse Wire Wheel
- 92255 RED-TRED® Zip Eraser Wheel



Model Number	Motor hp	Motor RPM	Wheel Size	Sound Level	Spindle Thread	Air Flow Rate CFM/SCFM	Air Inlet Thread	Hose Size	Air Pressure PSIG	Weight Pound	Length Inch	Height Inch
All	.4	3,200	4-1/2"	87 dB(A)	1/4" - 20 female	3/28	1/4" NPT	3/8"	90	2.5	12	5-1/2

AutobradeRed® FOR THE VALUE-MINDED PRO

Mini-Straight-Line Die Grinder

Model 18000

- 1/4" Collet, 25,000 RPM. Compact, lightweight, easy to use design.
- Rear exhaust, directs air away from work.
- Safety-lock lever throttle.
- Smooth, efficient air motor with built-in speed regulator.
- Optional collet insert: 1/8" (18432).



Model 18000

Mini-Right Angle Die Grinder

Model 18010

- 1/4" Collet, 20,000 RPM. Compact, lightweight design permits easy access to tight spots.
- Composite grip absorbs vibration and reduces cold air transmission to the operator.
- Rear exhaust, directs air away from work. Safety-lock lever throttle.
- Applications: high speed porting, blending and deburring where clearance is a factor.
- Optional collet insert: 1/8" (18432).



Model 18010

Die Grinder/Disc Sander Kit

18015

- Two tools in one! Convenient for surface preparation, scuffing, deburring and light-duty general jobs. Kit comes complete with accessories for easy conversion between die grinder/disc sander.
- Includes: Model 18010 Die Grinder – 20,000 RPM, rear exhaust, composite insulated grip; 3" hard density back-up pad; 3" trial pack of assorted coated and non-woven nylon abrasives; 50103 1/4"-20 shank; 94300 Dynaswivel®; deluxe storage/carry case.



18015 Kit

7° Offset Die Grinder

Model 18020

- 1/4" Collet, 20,000 RPM, front exhaust.
- 7° offset handle for comfort and control.
- Composite grip absorbs vibration and reduces cold air transmission to the operator.



Model 18020

TRY OUR CARBIDE BURRS –
SEE PAGE 43.



**GEARLESS
FOR LESS
MAINTENANCE**

Model Number	Motor hp	Motor RPM	Sound Level	Maximum Air Flow CFM/SCFM	Air Inlet Thread	Hose Size Inch	Air Pressure PSIG	Weight Pound	Length Inch	Height Inch
18000	.2	25,000	87 dB(A)	3/28	1/4" NPT	3/8	90	1	6-1/2	1-3/4
18010	.2	20,000	87 dB(A)	3/19	1/4" NPT	3/8	90	1.3	6-1/2	3
18020	.5	20,000	78 dB(A)	3/22	1/4" NPT	3/8	90	1.9	8	5-3/4

AutobradeRed® FOR THE VALUE-MINDED PRO

Disc Sanders

- 7° offset handle for comfort and control, front exhaust, safety-lock lever throttle. Composite grip absorbs vibration and reduces cold air transmission to the operator.
- Model 18160 includes 2" dia. locking-type pad; Model 18180 includes 3" dia. locking-type pad.

Model 18160
2" Diameter

Model 18180
3" Diameter

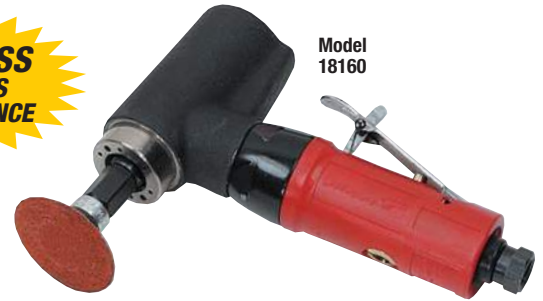

Model 18160

Model Number	Motor hp	Motor RPM	Sound Level	Spindle Thread	Air Flow Rate CFM/SCFM	Air Inlet Thread	Hose Size	Air Pressure PSIG	Weight Pound	Length Inch	Height Inch
18160	.5	20,000	78 dB(A)	1/4"-20 male	3/22	1/4" NPT	3/8"	90	1.8	8-1/2	5-1/2
18180	.5	20,000	78 dB(A)	3/8"-24 male	3/22	1/4" NPT	1/4"	90	1.9	8-1/4	5-1/4

Long Neck 3" Dia. Cut-Off Wheel Tool

Model 18075

- Extension design allows easier access to tight or confined areas. Plus, tool design allows for easier straight-type cuts! Offers better visibility of workpiece.
- 20,000 RPM with rear exhaust. Adjustable guard.
- Accepts standard 3" wheels with 3/8" center hole.
- Comfortable composite handle insulates from cold air.
- Plenty of power for everyday shop tasks.



Model 18075

ASK ABOUT NEW 4" DIA. REVERSIBLE MODEL!

3" Dia., 7° Offset Cut-Off Wheel Tool

Model 18080

- Accepts standard 3" wheels with 3/8" center hole.
- Design is similar to circular saw for added control.
- Front exhaust keeps work surface clear.
- Offset design provides maximum user comfort and control.
- Composite grip absorbs vibration and reduces cold air transmission to the operator.



Model 18080



Important: Always use proper guards, wear eye gear and body protection. Never mount wheels with lower maximum RPM rating than tool.

Model Number	Motor hp	Motor RPM	Sound Level	Maximum Air Flow CFM/SCFM	Air Inlet Thread	Hose Size Inch	Air Pressure PSIG	Weight Pound	Length Inch	Height Inch
18075	.5	20,000	87 dB(A)	3/28	1/4" NPT	3/8	90	2	12	3-1/2
18080	.5	20,000	85 dB(A)	3/22	1/4" NPT	3/8	90	2.2	8-3/4	5

Dual-Piston Sander

Model 18066

- 2,500 strokes per minute.
- Long board air-powered sander, two-handed operation.
- Accepts 2-3/4" wide x 17" long paper abrasives.
- Includes rubber pad with clips for securing abrasives.

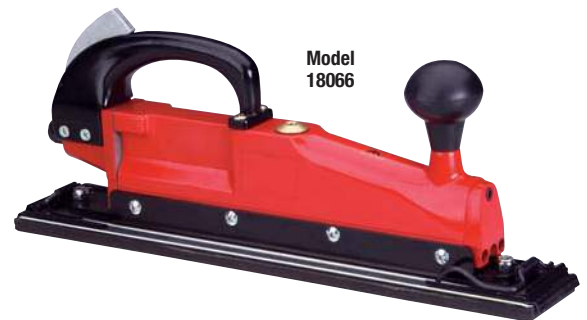

Model 18066

Model Number	Maximum Air Flow CFM/SCFM	Air Pressure PSIG	Air Inlet Thread	Weight Pound	Stroke Length Inch	Pad Size Inch	Paper Size Inch
18066	2/14	90	1/4" NPT	6	1	2-3/4 x 16	2-3/4 x 17-1/2

AutobradeRed® FOR THE VALUE-MINDED PRO

3" Dia., Right Angle Buffer

- Uses 3" diameter buffs. Built-in speed control, rear exhaust.
- 3/8"-24 male spindle. Safety-lock lever throttle.
- Composite comfort grip reduces cold air transmission to the operator.
- Includes 50126 Back-Up Pad (3" dia. hook-face) and 90034 Wool Buff (3-1/2" dia.).
- Ideal for small areas where full size buffers are too big.
- Polish aluminum wheels, side view mirrors and more.
- Buffing pad selection on page 44.

Model 18055
2,400 RPM

Model 18056
3,200 RPM



3" Dia., Right Angle Buffer/Spot Sander Kit

18058

- Excellent tool for spot repair and buffing/polishing. Angle-head design permits access to difficult areas.

Includes:

- 18055 2,400 RPM tool
- 50122 3" Hook-Face Backing Pad (3/8"-24)
- 90027 3" Terry Cloth Bonnet
- 90028 3" Synthetic Wool Pad
- 90034 3" Natural Wool Pad
- 90038 3" White Polishing Foam Pad
- 90044 3" Yellow Cutting Foam Pad
- 95723 4 oz. Finesse Creme
- 95727 4 oz. Dynabrade Glaze
- 54034 Random Orbit Sanding Head
- 54018 1-1/4" Sanding Pad
- 93191 Sample 9-Micron 1-1/4" Abrasive Discs
- 94300 Dynaswivel®
- Wrenches for Accessory Changes
- Deluxe Storage/Carry Case



Buffer

Model 18050

- 0 - 2,500 RPM free speed. Uses 5" to 8" diameter buffs.
- Insulated handle reduces cold air transmission to the operator.
- Common 5/8"-11 male spindle.
- Lightweight and compact in size.
- Rear exhaust, variable speed safety-lock lever throttle.
- Soft-grip handle can be positioned for right or left hand operation.
- Back-up pad (50853) and polishing bonnet (90082) not included.



Model Number	Motor hp	Motor RPM	Pad Size	Sound Level	Spindle Thread	Air Flow Rate CFM/SCFM	Air Inlet Thread	Hose Size	Air Pressure PSIG	Weight Pound	Length Inch	Height Inch
18050	.7	0-2,500	5" - 8"	87 dB(A)	5/8" - 11 male	3/27	1/4" NPT	3/8"	90	5.3	12	4
18055/18056	.4	2,400/3,200	3"	87 dB(A)	3/8" - 24 male	3/28	1/4" NPT	3/8"	90	2	10-3/8	2-1/2

Dynaswivel® Air Line Connectors

Never Fight an Air Hose Again!

- Dynaswivel® is a “universal-joint” that connects portable air tools to an air line.
- It improves tool maneuverability, minimizes operator fatigue and extends hose life.
- Patented; works great on air tools or paint guns.
- Choose from the most popular original Dynaswivel® style:
 - SWIVELS 360° AT TWO LOCATIONS which allows air hose to drop straight to the floor, no matter how the tool is held.
- OR, choose from the “single-pivot” style:
 - Right angle, “single-pivot” swivels 360° at one location. Permits 360° maneuverability of tool, while air hose extends horizontally.



1/8" NPT Model

95852

- 1/4" NPT and 1/8" NPT; fits small air tool.
- Air flow: up to 25 SCFM.
- Weight: 0.19 lb.
- Heavy duty aluminum.



1/4" NPT Model

95460

- Air flow: up to 25 SCFM.
- Heavy duty aluminum.



1/4" NPT, Composite Model

94300

- Air flow: up to 33 SCFM.
- Non-marring lightweight composite construction.
- Allows greater air flow than the “original” model (see 95460).



1/4" NPT, Flow Control Model

95734

- Air flow: up to 25 SCFM.
- Built-in dial allows for air flow control.
- Heavy duty aluminum.



1/4" NPT, Flow Control, Composite Model

94407

- Air flow: up to 46 SCFM.
- Built-in dial allows for air flow control.



1/4", 3/8" & 1/2" NPT, Single-Pivot

- Heavy duty aluminum.

95590

1/4" NPT

- Air flow: up to 25 SCFM.

95591

3/8" NPT

- Air flow: 26 to 45 SCFM.

95592

1/2" NPT

- Air flow: 46 to 65 SCFM.



3/8", 1/2" & 3/4" NPT Models

- Heavy duty aluminum.

95461

3/8" NPT

- Air flow: 26 to 45 SCFM.

95462

1/2" NPT

- Air flow: 46 to 65 SCFM.



95690

3/4" NPT

- Air flow: above 65 SCFM.

Ball-Swivel Plug

97016

- Offers 53° conical range of motion for added tool maneuverability and operator comfort.
- A natural fit with Dynabrade palm-style Random Orbital Sanders!
- Ported plug design allows air flow up to 74 SCFM.
- Maximum air pressure of 90 PSIG.



Important: 150 PSI maximum on all models. Do not use on percussion tools or in areas of high mechanical abuse.

Note: Do not exceed recommended torque value of 20 ft. lbs.

Push-Button, Composite Couplers & Plugs

Couplers

- Available in 1/4" female and male NPT styles.
- Lightweight 1.4 oz., non-marring composite material.
- Heavy duty construction.
- Shock-proof, low-vibration, crush-resistant.
- Easy push-button action to disconnect!



Female Coupler



Male Coupler

Part Number	Thread Size	Air Flow Range
94960	1/4" Female NPT	Up to 83 SCFM
94980	1/4" Male NPT	Up to 83 SCFM

Plugs

- Available in 1/4", 3/8" and 1/2" female and male NPT styles.
- Durable zinc-plated steel construction.
- Plugs have "ported" design to prevent "starving" of the air tool.
- Provides up to twice the air flow compared to standard plug design.

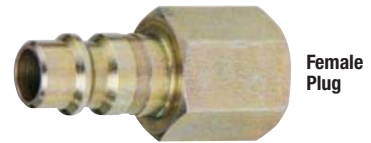

Female Plug



Male Plug

Part Number	Thread Size	Air Flow Range
95675	1/4" Male NPT	Up to 74 SCFM
95677	1/4" Female NPT	Up to 74 SCFM

Assemblies

- Available in 1/4" female and male NPT styles.
- Assembly includes one composite-style coupler and one plug.
- Maximum working pressure: 150 PSI.
- Temperature range: -4°F to 212°F.

Part Number	Coupler Thread Size	Plug Thread Size
94990	1/4" Female NPT	1/4" Male NPT
94991	1/4" Female NPT	1/4" Female NPT
94992	1/4" Male NPT	1/4" Male NPT
94993	1/4" Male NPT	1/4" Female NPT



Female to Male Assembly



Female to Female Assembly



Male to Male Assembly



Male to Female Assembly



Connect/Disconnect Air Hoses with Ease!

Spring-Action, Steel Couplers & Plugs

Couplers

- “Ported” design for maximum air flow!
- Available in 1/4", 3/8" and 1/2" female and male NPT styles.
- Durable nickel-plated steel and brass construction.
- Single action quick-connect by just inserting plug into coupler. Pull back on sleeve of coupler for quick disconnect.

Part Number	Thread Size	Air Flow Range
95674	1/4" Female NPT	Up to 74 SCFM
95684	1/4" Male NPT	Up to 74 SCFM
98261	3/8" Female NPT	Up to 138 SCFM
98262	3/8" Male NPT	Up to 138 SCFM
98269	1/2" Female NPT	Up to 138 SCFM
98270	1/2" Male NPT	Up to 138 SCFM



Female Coupler



Male Coupler

Plugs

- Available in 1/4", 3/8" and 1/2" female and male NPT styles.
- Durable zinc-plated steel construction.
- Plugs have “ported” design to prevent “starving” of the air tool.
- Provides up to twice the air flow compared to standard plug design.

Part Number	Thread Size	Air Flow Range
95675	1/4" Male NPT	Up to 74 SCFM
95677	1/4" Female NPT	Up to 74 SCFM
98263	3/8" Male NPT	Up to 138 SCFM
98264	3/8" Female NPT	Up to 138 SCFM
98271	1/2" Male NPT	Up to 138 SCFM
98272	1/2" Female NPT	Up to 138 SCFM

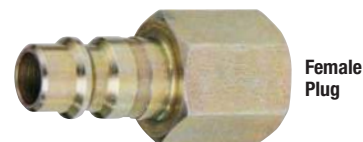

Female Plug



Male Plug

Assemblies

- Assembly includes one coupler and one plug.
- Available in 1/4", 3/8" and 1/2" female and male NPT styles.
- Maximum working pressure: 232 PSI.
- Temperature range: -4°F to 212°F.

Part Number	Coupler Thread Size	Plug Thread Size
95676	1/4" Female NPT	1/4" Male NPT
95850	1/4" Female NPT	1/4" Female NPT
95685	1/4" Male NPT	1/4" Male NPT
95851	1/4" Male NPT	1/4" Female NPT
98265	3/8" Female NPT	3/8" Male NPT
98266	3/8" Female NPT	3/8" Female NPT
98267	3/8" Male NPT	3/8" Male NPT
98268	3/8" Male NPT	3/8" Female NPT
98273	1/2" Female NPT	1/2" Male NPT
98274	1/2" Female NPT	1/2" Female NPT
98275	1/2" Male NPT	1/2" Male NPT
98276	1/2" Male NPT	1/2" Female NPT



Female to Male Assembly



Female to Female Assembly



Male to Male Assembly



Male to Female Assembly

Safety Couplers & Plugs

Unique “Two Step” safety disconnect system releases air pressure before tool is disconnected. Eliminates “hose whip.”

- Couplers and plugs have “Ported” design for maximum air flow!
- Ergonomically designed for easy one-hand operation!
- Advanced composite and stainless steel construction.
- Impact resistant with non-scratch surface.
- Aerodynamically-designed valve improves air flow to tool.
- Anti-static construction; cannot rust or corrode.
- Very lightweight to reduce operator fatigue.



Step One: Pull back on the sleeve and the compressed air is vented.

Step Two: Push forward on the sleeve to disconnect the coupler in complete safety!

Safety Couplers

Part No.	Coupler Body Size	Thread Size	Air Flow Range
97566	1/4"	1/4" Female NPT	Up to 55 SCFM
97567	1/4"	1/4" Male NPT	Up to 55 SCFM

- Disconnect steps are easily identified!



Plugs

Part No.	Plug Body Size	Thread Size	Air Flow Range
95675	1/4"	1/4" Male NPT	74 SCFM
95677	1/4"	1/4" Female NPT	74 SCFM



Safety Coupler/Plug Assemblies

Part Number	Coupler Body Size	Coupler Thread Size	Plug Body Size	Plug Thread Size
97572	1/4"	1/4" Female NPT	1/4"	1/4" Male NPT
97573	1/4"	1/4" Female NPT	1/4"	1/4" Female NPT
97574	1/4"	1/4" Male NPT	1/4"	1/4" Male NPT
97575	1/4"	1/4" Male NPT	1/4"	1/4" Female NPT

Female to Male Assembly

Female to Female Assembly

Male to Male Assembly

Male to Female Assembly



Air Line Test Gauge

94315

- Use to test air line pressure at selected areas of an air supply system.
- Comes complete with brass “T” connector, quick disconnect coupler and a round pressure gauge.



Accessories

DynaJet In-Line Blow Guns

- Connects only one time... mounts permanently between a coupler and air hose.
- Small, lightweight design, durable, aluminum construction, weighs only 2 oz.
- Each unit has 1/4" female NPT thread at both ends for easy installation.
- Purges air lines of water and/or contaminants before starting up air tools.
- Clean off work pieces and/or work stations after grinding and sanding.
- Recommended air flow range on both models is up to 35 SCFM.
- Model 94467 meets O.S.H.A. requirements of special relief hole in nozzle which limits pressure to 30 PSI when dead ended and used on an air line of 150 PSI or less.

94466
Standard Model

94467
Safety Tip Model



Dynabrade Air Lube

- Highly recommended in use of all Dynabrade tools.
- Absorbs up to 10% of its weight in water.
- Prevents rust and formation of gum and sludge.
- Keeps pneumatic tools operating longer with greater power and less downtime.

95821
4 oz.

95843
1 Gallon

95842
1 pt.



Grease and Grease Gun

- Multi-purpose grease for all types of bearings, cams, gears.
- High film strength: excellent resistance to water, steam, etc.
- Workable range 0° to 300°.

95541
Push-Type Grease Gun

95542
10 oz. Tube

- One-hand operation.



Dynabrade Finesse Creme and Glaze

- Finesse Sanding Creme is a sanding compound for metal, fiberglass and composites; use with fine-grade sanding discs.
- Glaze is for use with slow-speed tools to achieve a high-gloss finish after compounding.

95723
4 oz. Finesse Creme

95727
4 oz. Glaze

95724
1 qt. Finesse Creme

95728
1 qt. Glaze

95725
1 gal. Finesse Creme



Random Orbital Sander Accessories

Non-Vacuum to Vacuum Conversion Kits

- For use with Dynorbital-Spirit® and Dynorbital® Silver Supreme Random Orbital Sanders.
- All kits include PSA vacuum sanding pad, shroud, vac adapter and necessary hardware for quick and easy conversion!
- Hook-face pads may be substituted upon request.

*Kit No. 57104 can be ordered with no pad.



Non-Vac Tool Pad Diameter	Converts Tool To	Kit Part Number
3-1/2 (89 mm)	Self-Generated	57118
3-1/2 (89 mm)	Central Vacuum	57119
5 (127 mm)	Self-Generated	57120
5 (127 mm)	Central Vacuum	57121
6 (152 mm)	Self-Generated	57122*
6 (152 mm)	Central Vacuum	57123

Replacement Parts for Exhaust Assemblies

No.	Part #	Description	No.	Part #	Description	No.	Part #	Description
1	69364	Shroud Adapter	5	95526	O-Ring	9	56027	Muffler Insert (3)
2	57083	Vacuum Adapter	6	69353	Vac Nozzle	10	69359	Muffler Cap
3	96197	Dowel Pin	7	57067	Vac Tube	11	69273	Muffler Assembly
4	57066	Muffler Body	8	57093	Vacuum Adapter			

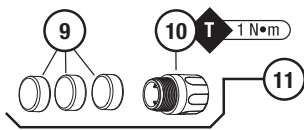

Non-Vacuum Exhaust

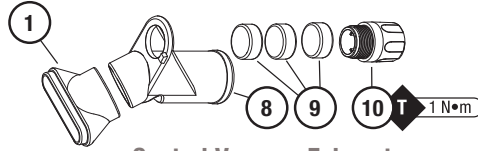

Central Vacuum Exhaust

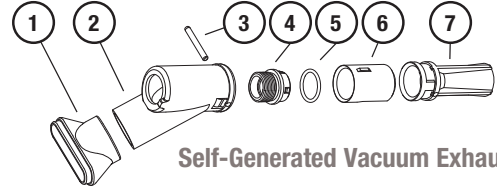

Self-Generated Vacuum Exhaust

Dynorbital-Spirit® Replacement Drop-In Motors

- Allows quick and easy replacement.
- No motor adjustments needed.
- Follow maintenance procedures described in parts page.



Select Tool Orbit and Size:

Diameter Orbit	3" Dia. Models	3-1/2" Dia. Models	5" Dia. Models	6" Dia. Models
3/8"	59450	59450	59453	59456
3/16"	59451	59451	59454	59457
3/32"	59452	59452	59455	59458

Note: 3/8" motor includes new lock ring.

Dynorbital® Silver Supreme Replacement Drop-In Motors

- Allows quick and easy replacement.
- No motor adjustments needed.
- Follow maintenance procedures described in parts page.



Select Tool Orbit and Size:

Diameter Orbit	3" Dia. Models	3-1/2" Dia. Models	5" Dia. Models	6" Dia. Models
3/8"	69450	69453	69456	69459
3/16"	69451	69454	69457	69460
3/32"	69452	69455	69458	69461

Note: 3/8" motor includes new lock ring.

Optional Vacuum Overskirts

- Enhances vacuum pick-up!
- **57084** – 3" & 3-1/2" Models
- **57086** – 5" Models
- **57087** – 6" Models



Repair and Tune-Up Accessories

57098 Full Service Repair Kit

- Special tools for proper disassembly/assembly of Dynorbital-Spirit® and Dynorbital® Silver Supreme sanders.
- Includes: 57092 Repair Collar
56058 Lock Ring Wrench
56056 Bearing Puller
57091 Bearing Press Tool
57099 Bearing Puller
96034 12 mm Hex Wrench



59459 Drop-In Motor Repair Kit

- Special tools for proper disassembly/assembly of Dynorbital-Spirit® and Dynorbital® Silver Supreme drop-in motors.
- Includes: 57092 Repair Collar
56058 Lock Ring Wrench



96510 Tune-Up Kit for Dynorbital-Spirit® Sanders

- Tune-up kit contains high and medium wear parts.



96620 Tune-Up Kit for Dynorbital® Silver Supreme Sanders

- Tune-up kit contains high and medium wear parts.



50679

- Replacement 26 mm open-end wrench for changing sanding pads.



Accessories

Random Orbital Head Kit

61374

- Turn your rotary buffer into a swirl-free finishing tool! Fast, easy conversion and removal.
- Large 3/4" offset simulates hand polishing action. Ideal for final finishing. 3,200 maximum RPM.
- Random action prevents "burn through" on edges of clear coat finishes. No heat build-up means no "haze" or swirl-marks, surface stays cool.
- Includes Random Orbital Head, wrenches, weight-mated Hook-Face Backing Pad (50855) and Sheepskin Buff (90082).



Fits most buffers with common 5/8"-11 spindle

Hook-Face pad

3/4" ORBIT Random Action



Cut & Polish Rotary/Random Orbital Head

61384

- Run pad in rotary (cut) mode for initial buffing and removing dust nibs, light scratches, oxidation and "orange peel." Then switch to random orbital (polish) mode for buffing to a swirl-free finish with no "haze" or "halo" effects!
- A great time-saver when a "final finish" is required!
- Includes cut & polish head, wrenches, 50855 Hook-Face Backing Pad and 90082 Natural Sheepskin Polishing Buff.

Common 5/8"-11 spindle

Patent Pending



CUT with Rotary Motion

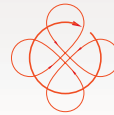

POLISH with 3/4" Offset Random Action

Hook-Face Pads

Part No.	Diameter	Thread Size	Description
50120	3"	1/4"-20 Female	Foam Backing
50122	3"	3/8"-24 Female	Foam Backing
50125	3"	1/4"-20 Female	Rigid Backing
50126	3"	3/8"-24 Female	Rigid Backing
50146	4"	1/4"-20 Female	Rigid Backing
50147	4"	3/8"-24 Female	Rigid Backing
50884	5"	5/8"-11 Female	Rigid Backing
50946	6"	5/8"-11 Female	Foam Backing
50853	7"	5/8"-11 Female	Rigid Backing
50947	8"	5/8"-11 Female	Foam Backing



50122



50126

Dynaburr Carbide Burrs

- Used for grinding, deburring, and finishing on stainless steel and other metals.

93350

1/4" Dynaburr Kit

- Includes 8 carbide burrs.

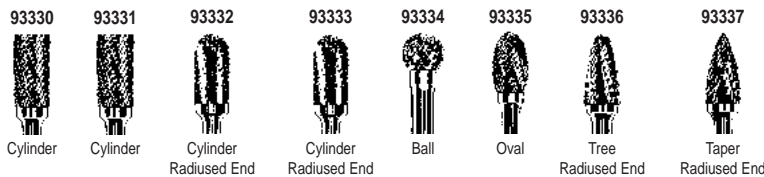

93330

93331

93332

93333

93334

93335

93336

93337

Cylinder

Cylinder

Cylinder Radiused End

Cylinder Radiused End

Ball

Oval

Tree Radiused End

Taper Radiused End



93350

93351

1/8" Dynaburr Kit

- Includes 12 carbide burrs.

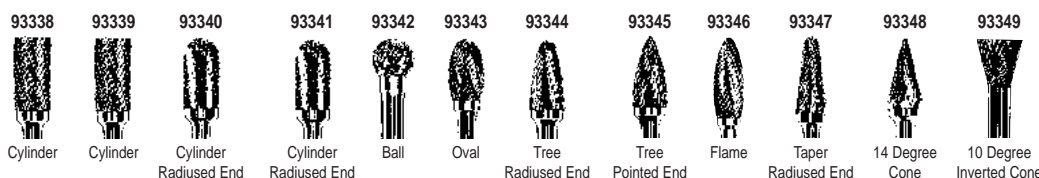

93338

93339

93340

93341

93342

93343

93344

93345

93346

93347

93348

93349

Cylinder

Cylinder

Cylinder Radiused End

Cylinder Radiused End

Ball

Oval

Tree Radiused End

Tree Pointed End

Flame Radiused End

Taper Radiused End

14 Degree Cone

10 Degree Inverted Cone



93351

Accessories

Filter-Regulator-Lubricator

- Provides accurate air pressure regulation, two stage filtration of water/contaminants and lubrication of pneumatic components.

Filter

- Five-micron filter element is standard.
- Manual push-button drain easily discharges contaminants.

Part Number	Air Inlet Thread
10671	1/2" NPT



Regulator

- Compensation built into unit responds faster to changes in incoming pressure and flow.
- Built-in PSI pressure dial gauge.

Part Number	Air Inlet Thread
10673	1/2" NPT



Lubricator

- Built-in check valve permits tool to be filled with oil without having to turn off air pressure.
- Adjustable oil drop to meter amount of oil into air system.

Part Number	Air Inlet Thread
10675	1/2" NPT



Each unit includes two bushings for easy conversion to 3/8" NPT.

Additional Specifications: Maximum Operating Pressure 145 PSIG.

Filter-Regulator

- Unit has modular connections with mounting brackets for easy installation.

Part Number	Air Inlet Thread
10677	1/2" NPT



Regulator-Lubricator

- Unit has modular connections with mounting brackets for easy installation.

Part Number	Air Inlet Thread
10679	1/2" NPT



Filter-Regulator-Lubricator

- Unit has modular connections with mounting brackets for easy installation.

Part Number	Air Inlet Thread
10681	1/2" NPT



FRL Flow Characteristics

Flow • SCFM (LPM)	Pressure Drop Across FRL • PSI (Bar)
15 (425)	2.0 (.14)
30 (850)	3.0 (.21)
45 (1274)	6.0 (.41)
60 (1699)	7.0 (.48)
75 (2124)	8.0 (.55)

Dynabrade Locking-Type Pads

- Locking-type sanding pads available in three diameters.
- Constructed of durable, non-marring material.
- "Type-R" locking-type abrasive discs thread directly into Dynapad® back-up pad, allowing quick change of abrasives.



Part No.	Diameter	Female Thread	Pad MOS RPM
51344	2"	1/4"-20	30,000
51345	2"	3/8"-24	30,000
51346	3"	1/4"-20	20,000
51347	3"	3/8"-24	20,000
50192	4"	3/8"-24	12,000

3" to 7" Hook-Face Buffing Pads

- Use on two-hand or palm-style buffers.



Size	Part No.	Description	Type/Color
3"	90027	Terry Cloth	N/A
3"	90028	Synthetic Wool	N/A
3"	90038	Foam Flat Face	Polishing/White
3"	90044	Foam Flat Face	Cutting/Yellow
3"	90080	Natural Wool	Sheepskin
3-1/2"	90034	Natural Wool	Sheepskin
5"	90036	Wool	Thick Pile
5"	90040	Foam Flat Face	Polishing/White
5"	90045	Foam Flat Face	Cutting/Yellow
5"	90081	Natural Wool	Sheepskin
6"	90046	Foam Flat Face	Cutting/Yellow
6"	90047	Foam Flat Face	Polishing/White
7"	90082	Natural Wool	Sheepskin

Accessories

RED-TRED® Eraser Disc

92295 Complete Assembly



Patent Pending

- Maximum 3,500 RPM.
- Includes:
92298 Backing Plate
92297 Disc
04127 Flange
96507 Pin Wrench



92295



92298 Backing Plate



92297 Replaceable Disc (4" dia.) features "Staggered Teeth" Design for effective material removal and enhanced cooling of work surface



04127 Flange (5/8"-11) fits most Buffing Tools

DynaZip Accessories (Also Fit Competitive Tools)

Wire Wheels



Part No.	Size	Grade	Use	Tip Type
92245	4" dia. x 3/4" wide	Coarse	Sealants	Bent
92246	4" dia. x 3/4" wide	Medium	Rust	Bent
92247	4" dia. x 3/4" wide	Fine	Paint Removal	Straight
92248	4" dia. x 1/2" wide	Coarse	Sealants	Bent

Threaded Adapters



Part Number	Mounts to	Exposed	Shank Dia.	Length (Inch)
50103	1/4" Collet	1/4"-20 Male Thread	1/4"	1-1/4
51032	1/4" Collet	1/4"-20 Female Thread	1/4"	1-1/2
50106	3/8"-24 Male Thread	1/4"-20 Male Thread	-	1-1/16
54021	1/4"-28 Female Thread	1/4"-20 Male Thread	-	1-3/16
54040	5/8"-11 Male Thread	5/16"-24 Female Thread	-	1-5/8
55034	3/8"-24 Male Thread	5/8"-11 Male Thread	-	1-3/8

RED-TRED® Eraser Decal Removal Wheel

92255 Eraser Wheel Only (Also Fits Competitive Tools)

92257 Eraser Wheel with Hub

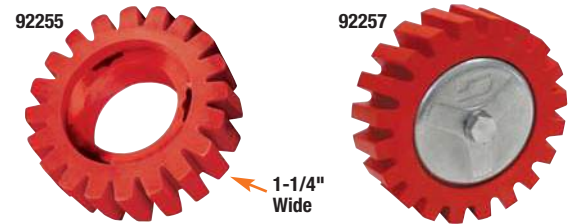

SEE DISPLAY PACKAGING ON PAGE 61!

Wheel Hub Assembly

92284

- Mounts the 3/4" wide wire wheels; also mounts the 92255 Eraser Decal Removal Wheel.



DynaMitt Sanding Glove

58005

- Sand difficult shades with ease – great for custom work. Give your fingers a break!
- Easily control pressure and sanding coverage.
- Includes rubber insert for more rigid applications. Insert fits into pocket under hook-face area.



Sample Abrasive Kit

58009

Mini-Dynorbital® Sanding Pads

- For PSA discs only.



54017



54018



Part Number	Pad Dia.	Description Face	Thread Type
54017	3/4"	Medium/Rubber	1/4"-20 Female
54018	1-1/4"	Medium/Rubber	1/4"-20 Female
54031	1-1/4"	Soft	Locking-Type
54085	3/4"	Very Soft	1/4"-20 Female
54086	1-1/4"	Very Soft	1/4"-20 Female
54087	3/4"	Soft/Vinyl	1/4"-20 Female
54088	1-1/4"	Soft/Vinyl	1/4"-20 Female

Downdraft Sanding Tables

- Keep shop area free of dust while sanding, grinding, etc.
- Great for sanding:
 - Fiberglass spoilers and wings
 - Doors and quarter panels
 - Motorcycle frames, fenders and gas tanks
 - Custom car, truck and van parts, etc.
 - Fiberglass parts
 - Bumper covers
- Easy to use, safe, unlike flimsy fender stands.
- No vacuum-type tools needed; use any sander/grinder.
- Keep machine on even when not in use – table actually filters air to help clean the shop environment.



Standard Duty Models

- | | | |
|---|-------------------------------|-------------------------------|
| 64201 | 64699 | 64700 |
| • 33" W x 41" L working area. | • 33" W x 60" L working area. | • 36" W x 72" L working area. |
| • Dual filtration – includes three 20" wide x 25" long x 2" thick, 1-micron pleated filters, and one 5-micron pre-filter blanket. | | |
| • Includes 5" diameter casters and two dust-tight electric outlets. | | |
| • Rhino Linings® coated tabletop is durable and anti-slip. | | |
| • Two handy storage compartments for tools and accessories. | | |

Specifications

- **Power Source:** One heavy duty electric motor, 1.0 Hp
- **Electric Capacity:** 110 volt, 220 volt (single phase). Three phase available upon request.
- **Two Paper Filter Sizes Available:**
 - 64671: 20" wide x 25" long x 2" thick standard paper air filter
 - 64672: 20" wide x 25" long x 2" thick UL rated class I non-flammable air filter.



Heavy Duty Model

- **64657**
- 48" wide x 96" long working area. Includes six 20" x 25" paper filters (64658) and four 16" x 25" paper filters (64659).
- Dual filtration – 5-micron pre-filter blanket and 1-micron paper filters.
- High quality reverse incline blowers. Heavy duty TEFC twin electric motors. Non-slip surface for easier tool maneuverability.
- Up to 70% more filter area than competitive brands.
- Base unit is all-metal construction with CNC milled 3/4" MDF tabletop.
- Optional anti-static and anti-slip mat available (P/N 64970) as well as optional 5" diameter casters.

Specifications

- **Power Source:** Two heavy duty TEFC electric motors, 1.5 Hp
- **Electric Capacity:** 115 volt (single phase). 208 volt (three phase), 230 volt (single phase), 230 volt (three phase), 460 volt (three phase) available upon request.
- **Sound Level:** 72 dB(A)
- **Shipping Weight:** 820 lbs.



Model Number	Motor Hp	Volts	Phase	Vacuum Suction	Sound Level	Working Area Width	Working Area Length	Height Inch	Shipping Weight
64201	1	110/220	1	3,000 CFM	72 dB(A)	33"	41"	36	275 lbs.
64657	1.5 (dual)	115	1	7,000 CFM	75 dB(A)	48"	96"	36	970 lbs.
64699	1	110/220	1	3,000 CFM	72 dB(A)	33"	60"	36	285 lbs.
64700	1	110/220	1	3,000 CFM	72 dB(A)	36"	72"	36	365 lbs.

Electric Portable Dry Vacuums

- For use with air tools – setup for two-tool operation.
- A cost-effective solution versus overhead central-vac systems.
- Quiet operation – only 76 dB(A).

Model 61300
9.9 Gallon

Model 61301
17 Gallon

Variable Vacuum Control

Adjust your vacuum flow, based on type of tool and work surface.

Automatic ON/OFF

Vacuum starts and stops with use of tool. Saves time and conserves energy!

H.E.P.A. Filtration

Retains 99.97% of ultra-fine particles (High Efficiency Particulate Air), as small as 0.3 microns in diameter.

Extra Thermal Protection Device

Additional safeguard against overload of electronic motor.

Two-Tool Setup

Connect and operate two tools simultaneously! Allows more efficient use of workshop space.



Each unit includes everything shown.

Electronic Thermal Protection Device

Prevents motor overload.

Heavy Duty Four-Wheel Trolley

The ultimate in portability! Vacuum unit effortlessly glides from one workstation to another.

“Tilt ‘n Clean” Stainless Steel Drum

Easily tilts backward for quick emptying. Requires no heavy lifting or tiresome bending! 9.9 or 17 gallon capacity.

Two 20-Foot Hoses

are included. Ultra-flexible and lightweight air and exhaust hose.

TWO YEAR Limited Warranty!
We back our quality with twice the coverage of competitive models (see page 2).

Model Number	Capacity Gallon	Voltage / Frequency	Watts/hp	Air Pressure PSIG	Water Static Lift Inch	Shipping Weight lbs.	Height Inch	Width Inch
61300	9.9	120V/60 Hz	1,300/1.75	90	90	48.4	38-1/2	20-7/8
61301	17	120V/60 Hz	1,300/1.75	90	90	61.6	44-7/8	27-5/8

17 Gallon Vacuum Combo Kit

- Included with each kit is two Dynorbital-Spirit® Random Orbital Sanders.
- 3/16" diameter orbit, central vacuum-ready.
- 6" diameter pads, with choice of PSA or Hook-Face Pads.

Model 10010

- Includes Sanders with PSA pads.

Model 10011

- Includes Sanders with Hook-Face pads.



Pneumatic Portable Dry Vacuum System

Model 64625

- 10 gallon capacity.
- Includes package of five dust bags (64627).

- **Stainless Steel Construction**
- **Air Flow Adjustment Dial**

- **Top Tool Shelf**
- **Two 16' Coaxial Hose Assemblies**

Model Number	Capacity Gallon	Air Pressure PSIG	Water Static Lift Inch	Sound Level	Shipping Weight lbs.	Height Inch	Width Inch
64625	10	110-120	90	73 dB(A)	48	44	19

Electric Portable Dry Vacuum Accessories

Conductive "Y" Connector

31968

- Allows two tools to be connected to Dynabrade Portable Vacuum.

Conductive Inlet

31964

- Attaches "Y" Connector to Dynabrade Portable Vacuum.



Vacuum Trays

- Help organize tools, abrasives, etc.

96567 9.9 Gallon

96563 17 Gallon



Hose Hanger

96581

- Keeps hoses out of the way and off the floor.
- Can be placed anywhere on the trays for your convenience.
- Requires vacuum tray.

Wall Mount Bracket

For 9.9 Gallon Vacuum Only

96534

- For those wanting a stationary vacuum.



Locking Front Wheel

80051

- Stabilize vacuum movement.



Cleaning Kit

96558

- Attachments for other cleanup jobs.
- Includes 6' long x 1-1/4" dia. vacuum hose, curved handle and two extension pipes along with round brush, crevis tool and coarse dirt nozzle attachments.



Edge Guard

For 9.9 Gallon Vacuum Only

61361

- Prevents scratching of surfaces when not on trolley.



Filters

64683

Standard Filter

- 1-micron filtering.

64684

H.E.P.A. Filter

- The highest in cartridge filtration; 0.3-micron filtering.



Closing Vacuum Bags

- Strong disposable vacuum bags that have a closing feature for unwanted contamination. 0.5-micron filtering. Package of 10 bags.

64682 9.9 Gallon

80076 17 Gallon



Vacuum Hoses

3/4" Diameter Exhaust Hoses

95729

- Hose by-the-foot (no cuffs). Specify length desired. Order 95602 Factory-Installed Cuffs, if desired.



1" Diameter Exhaust Hoses

50682

- 6 feet long with two cuffs.

95709

- 10 feet long with two cuffs.

95395

- Hose-by-the-foot (no cuffs). Specify length up to 50 feet. Order 95599 Factory-Installed Cuffs, if desired.

1-1/4" Diameter Exhaust Hoses

54205

- Hose-by-the-foot (no cuffs). Specify length up to 50 feet. Order 95894 Factory-Installed Cuffs, if desired.



1-1/2" Diameter Exhaust Hoses

95847

- Hose-by-the-foot (no cuffs). Specify length up to 50 feet.



Vacuum Hose Swivel Adapters

- Adds flexibility to vacuum hose connection.

96572

1" Swivel Adapter

96573

1-1/4" Swivel Adapter



Hose Cuffs

All measurements are I.D.

95601



3/4" Thread

3/4" Non-Thread

95396



1" Thread

1" Non-Thread

95800

- Use optional 95895 Insert to mount to tool's vacuum outlet on non-thread end.



1-1/4" Thread

1-1/4" Non-Thread

96413



1-1/4" Thread

1-1/2" Thread

95894



1-1/4" Thread

1" Non-Thread

96412

- Use to connect two 1-1/4" hoses.



1-1/4" Thread

1-1/4" Thread

96006

- Cuff swivels.



1-1/4" Thread

1" Non-Thread

96414



1-1/2" Non-Thread

1-1/4" Thread

95699



1-1/4" Non-Thread

1-1/2" Thread

96102

- Use optional 95895 Insert to mount to tool's vacuum outlet; or 95396 Hose Cuff for 1" exhaust hose.



1-1/2" Thread

1-1/4" Non-Thread

96103



1-1/2" Thread

1" Non-Thread

97051



2" Non-Thread

1-1/2" Thread

95698

- Cuff swivels.



2" Non-Thread

2-1/4" Thread

96004

- Cuff swivels.



1-1/4" Thread

1-1/4" Non-Thread

96104



1-1/2" Thread

1" Non-Thread

- Keeps air line out of the way.

95700

- Includes 95699 Cuff Adapter and 95698 2" Swivel Cuff.

- Use with optional 95396 Hose Cuff for 1" Exhaust Hose.



2" Thread

1-1/4" Non-Thread

96580

- Hose Assy.



1-1/4" Thread

2" Non-Thread

54208



1" Thread

1-1/4" Non-Thread

Conductive Vacuum Hoses & Cuffs

*Carbon-Impregnated to Shield Operator From Electrostatic Discharge (ESD)!
Ideal for Use with Dynabrade Portable Vacuum and Vacuum Tools*

- Conductive Vacuum Hoses & Cuffs shield operator from ESD, by surrounding the static charge and safely conducting it to ground.
- Conductive parts are carbon-impregnated and have no wearable coating. They provide permanent protection for the life of the hose or cuff.



Vacuum Hoses

Part No.	Hose Diameter
31920	1-1/4" (specify length)
31921	1" (specify length)
31924	1" x 6' long
31925	3/4" (specify length)

Hose Cuffs

Part No.	Connection (To Hose / To Tool)
31900	1" Thread / 1" Non-Thread
31901	1-1/2" Thread / 1" Non-Thread
31902	1-1/4" Thread / 1" Non-Thread
31904	1-1/4" Thread / 1-1/4" Non-Thread

Part No.	Connection (To Hose / To Tool)
31905	1-1/4" Vac Swivel Adapter
31907	1-1/4" Thread / 1" Non-Thread - Swivel
31908	3/4" Thread / 3/4" Non-Thread
31909	1" Thread / 1-1/4" Non-Thread

Conductive Coaxial Vacuum Hose Assembly

For Dynabrade Vacuum Systems

See Page 46 for Electric Models 61300 and 61301

31962

1-1/4" Diameter x 20' Long (32 mm x 6 m)

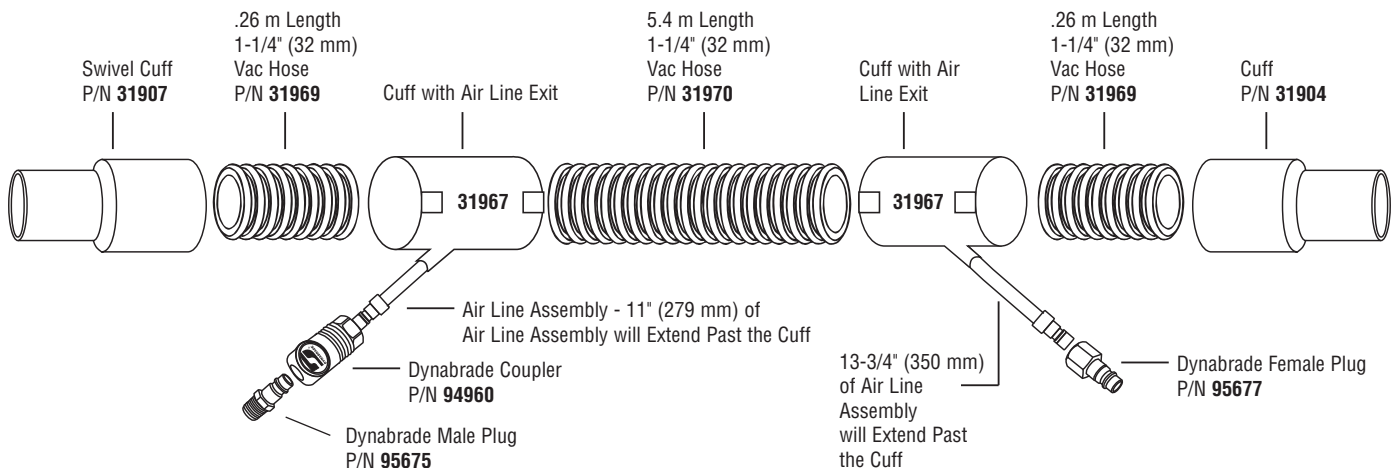

Coaxial Vacuum Hose Assemblies

For Dynabrade Vacuum Systems

See Page 46 for Electric Models 61300 and 61301

94941

1-1/4" x 20 ft.

- Includes everything as shown below.
- Air line is inside of exhaust hose for ease of use and convenience.

Compared To The Competition:

- 2 - 4 ft. longer.
- 2 lbs. lighter.
- More flexible exhaust hose.
- 66% lighter airline – see below for specific details.
- Added features of the swivel adapter, Dynabrade's button-release coupler.

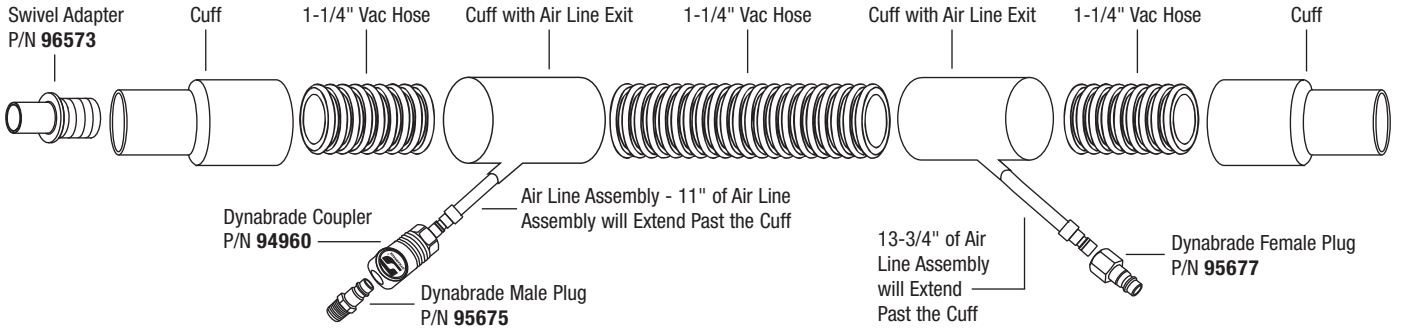

Air Line Accessories

10 mm Air Hose with Reusable Fittings

Lightweight Design with "Non-Crimp" Fittings to Ensure Hose Integrity!

- 10 mm Air Hose offers great flexibility, improves tool maneuverability and reduces operator fatigue.
- Designed to weigh 66% less than conventional rubber hoses!
- Reusable fittings (see below) ensure no crimping of air hose, eliminating potential hazard. (Standard fittings often crimp hose, creating weak spot where air bubble may form.)
- Fittings may be removed and used again, saving time and money!
- Hose offered in various lengths with two fittings included; also in longer roll (see chart).



Part Number	Hose Length Feet (Meters)	94898 Fittings Included
94856	5' (1.5 m)	Male - Male
94857	12' (3.7 m)	Male - Male

Part Number	Hose Length Feet (Meters)	94898 Fittings Included
94858	25' (7.6 m)	Male - Male
94859	164' (50 m)	–

"Non-Crimp" Hose Fittings

Easy, Secure Connection to Hose

94898

Includes Two Fittings

- **Fitting A** has threaded ferrule. This is fitted over outside diameter of hose.
- **Fitting B** has threaded barb, which is inserted into hose (ensuring that hose is completely seated).
- **Fitting A** and **Fitting B** are then thread-connected, and tightened until secure.

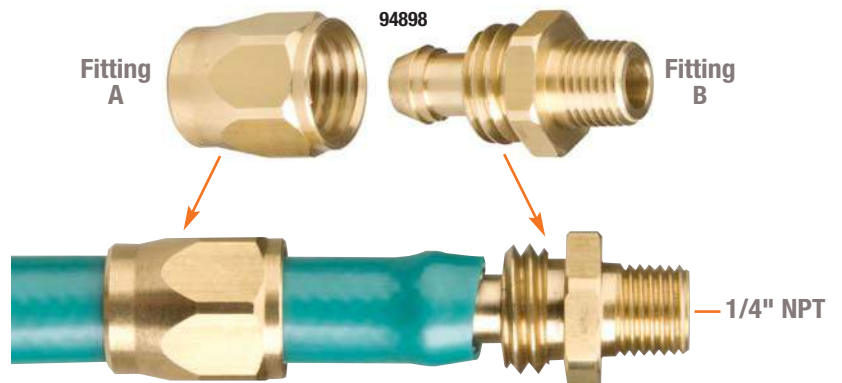

Air Line Accessories

Flex-Hose Air Line

- Abrasion resistant.
- For use on air tools and spray equipment.
- Two-thirds lighter than PVC/rubber-type hose.
- 290 lbs. working pressure. 870 PSI burst strength.

**LIGHTWEIGHT,
TOUGH AND HIGHLY
FLEXIBLE!**

3/8" Sizes

94851

- 12 ft. with male to male fittings.

94876

- 25 ft. with male to male fittings.

94853

- 50 ft. with male to male fittings.

94860

- 328 ft., bulk roll, no fittings.

94852

- 12 ft. with male to female fittings.

94892

- 25 ft. with male to female fittings.

94854

- 50 ft. with male to female fittings.

96569

- Hose-by-the-foot, up to 328 ft, no fittings.



Factory Installed Fittings

96497

- Male and male.

96491

- Male and female.

Air Line Hoses

95361

- 5 feet long, with male and female fittings.

11292

- 3/8" I.D. with two 1/4" male fittings. 8 feet long.

95938

- One set, factory-installed male and female fittings.

95807

- 1/4" air line custom length, no fittings (specify length). Use 95938.

95580

- 28 inches long with male and female fittings.

95870

- 1/2" I. D. with male and female fittings. 5 feet long.

94855 Whip Hose Assembly

- Includes 5 feet long hose, fittings and 94300 Composite Dynaswivel®.



Swivel Air Line Hoses

- Eliminates kinking. Tough, flexible and lightweight.
- Fittings swivel 360° for easy use.

Part No.	Description	Hose Dia.	Length
96217	1/4" Female to 1/4" Male	1/4"	3 ft.
96218	1/4" Female to 1/8" Male	1/4"	3 ft.
96219	1/4" Female to 1/4" Male	1/4"	6 ft.
96220	1/4" Female to 1/8" Male	1/4"	6 ft.
96221	Hose by the foot (no fittings). Order fittings separately, if desired.	1/4"	Custom
96225	1/4" NPT Female Fitting	For 1/4" Hose	–
96226	1/4" NPT Male Fitting	For 1/4" Hose	–
96227	1/8" NPT Male Fitting	For 1/4" Hose	–
96228	1/4" NPT Female Fitting	For 3/8" Hose	–
96229	1/4" NPT Male Fitting	For 3/8" Hose	–



Vacuum Accessories

6' Long Flex-Hose Systems

- All systems include 6' long flex-hose.

50617

- Has 50683 Standard Reusable Cloth Bag with hook 'n loop closure for easy emptying.

56303

- Has 56304 Reusable Cloth Bag with zipper-lock closure.

54420

- Includes 50683 Cloth Bag, 95361 6 ft. air line, 95362 Rubber Connectors and 50682 Exhaust Hose.



Bag-In-A-Box System

54217

- Includes: 95816 Air Line 11' long, 95709 Flex-Hose (1" dia. x 10' long), 95362 Rubber Connectors (5) and 95575 Durable Box Receptacle.
- Sample paper bag included. Paper bag reorder: 50692 (400/case) or 50693 (24/pkg.)

Longer hose lengths available for both systems! Also available without bag and box: Order 95820 Hose Assembly which includes 95816, 95709, and 95362 described above.



Reusable Cloth Bags

56304

- With zipper. Both these collection bags measure 14-1/2" long x 7-1/2" wide and connect to vacuum hose. 5-micron filtration.

50683

- With hook 'n loop closure.



Mini-Reusable Cloth Bags

50694

- 11" long x 3" wide bag connects to vac hose or directly to tool.
- Has hook 'n loop closure. 5-micron filtration.

54284

- 95580 Air line 1/4" dia. x 28" long.
- 50638 Flex-hose 1" dia x 18" long.
- 50694 Mini-Reusable Cloth Bag.
- 95362 Rubber Bands which connect air line to exhaust hose.



Hose Cover

95986

- 5' long cloth cover.
- Covers air line and exhaust/vacuum hoses (not included).
- Eliminates damage from hoses dragging on the workpiece.



Vacuum Accessories

Exhaust Hose Assembly

95820

- 1" diameter x 10' long.
- 95709 Flex Hose (1" dia., 10' long with cuffs).
- 95816 Air Line (1/4" dia., 11' long).
- 95362 Rubber Bands.
- Use with Dynorbital® sanders.



Rubber Bands

95362

- Five per package. Used to strap tool air line to tool's exhaust hose for easy "all-in-one" maneuverability.



In-Line Speed Regulators

- Mounts directly to air tool.

95745

- 1/4" NPT connection (25 CFM).

95746

- 3/8" NPT connection (26-45 CFM).



Respirator Masks

- Dynabrade's new Respirator Masks help filter out airborne particles. Ideal for workplaces where grinding, sanding, deburring and buffing take place.
- N95 – NIOSH approved. N95 rating indicates the mask blocks 95% of particles 0.3 microns in size and larger!
- Both styles are double-strapped and feature adjustable nosepiece for added comfort.
- Disposable, lightweight and maintenance-free!
- Masks are packaged 20 per box.

15465

- Standard mask.

15462

- Includes Exhalation Valve, which allows exhaled air to exit without outside air returning into valve. This also reduces breathing resistance and hot air buildup within mask.



Sanding Pads

3" (76 mm) Diameter Vacuum Sanding Pad

For Use with 10127 Dynabuffer

56142

- Hook-Face, premium urethane, medium density, 5/16"-24 thread.
- Also used with 3" (76 mm) diameter HiVac Random Orbital Sanders. 6 holes allow maximum source capture.



56142

**SEE MORE
SANDING PADS
ON PAGE 55!**

Sanding Pads For All Random Orbital Sanders / DynaLocke®

- All pads: 5/16"-24 male thread. • 13,000 RPM maximum rated. • Fit most brands of orbital sanders. • Perfectly balanced for use with Spirit sanders!

<p>Good Rubber Pad</p> 	<p>Better Urethane Value Line</p>  <p>PSA Only</p>	<p>Best (Standard on Tools) Premium Urethane</p>  <p>PSA and Hook-Face</p>	<p>Best (Channel-Vac Pads) Premium Urethane</p> <ul style="list-style-type: none"> • Circular recessed channel is 1/8" deep into the pad face connecting the pad's vacuum holes. • Eliminates need to align the pre-punched holes in the abrasive with the holes in the pad. • Great for production situations. 
---	--	---	---

3/8" Thick, Low Profile

PSA

Pad Construction	Density	5" Diameter		6" Diameter	
		Non-Vacuum	Vacuum	Non-Vacuum	Vacuum
Rubber	Medium	50630	50631	50632	50633
Rubber Post Pattern	Medium	–	50695	–	50696
Value Urethane	Medium	56205	56207	56206	56208
Premium Urethane	Soft	56102	56100	56103	56101
Premium Urethane	Medium	56106	56104	56107	56105
Premium Urethane Channel-Vac	Soft	–	56251	–	56261
Premium Urethane Channel-Vac	Medium	–	56252	–	56262

Hook-Face, Short Nap

Premium Urethane	Soft	56157	56155	56158	56156
Premium Urethane	Medium	54325	54326	54327	54328
Premium Urethane Channel-Vac	Soft	–	56253	–	56263
Premium Urethane Channel-Vac	Medium	–	56250	–	56260

Hook-Face, Long Nap (For Non-Woven Nylon)

Rubber	Medium	50605	50607	50606	50610
--------	--------	-------	-------	-------	-------

5/8" Thick, All Premium Urethane

- A thicker pad conforms more easily to curved and contoured surfaces and makes it ideal for featheredging.

PSA

Density	3" Diameter Dual Purpose		5" Diameter		6" Diameter	
	3-1/2" Diameter Dual Purpose	3-1/2" Diameter Dual Purpose	Non-Vacuum	Vacuum	Non-Vacuum	Vacuum
Soft	56086	56097	56185	56186	56187	56188
Medium	56084	56098	56175	56176	56177	56178
Channel-Vac Soft	–	–	–	56256	–	56266
Channel-Vac Medium	–	–	–	56254	–	56264

Hook-Face, Short Nap

Soft	–	54311	56195	56196	56197	56198
Medium	56087	54313	56180	56181	56182	56183
Channel-Vac Soft	–	–	–	56257	–	56267
Channel-Vac Medium	–	–	–	56255	–	56265

Hook-Face, Long Nap (For Non-Woven Nylon)

Medium	56090	54314	–	–	–	–
--------	-------	-------	---	---	---	---

Sanding Pads

Mesh Abrasive Vacuum Pads

- Vacuum sanding pads compatible with mesh abrasives for improved finish and longer abrasive life (mesh abrasives from Mirka Co. for example are screen-like on grit side and hook on back).
- 13,000 RPM maximum operating speed. Common 5/16"-24 male thread on 5" and 6" pads. 3/8" thick. Premium urethane resists heat and provides longevity.

56320 5" Diameter

- 44 holes.

56321 6" Diameter

- 52 holes.

56322 8" Diameter

- 48 holes.

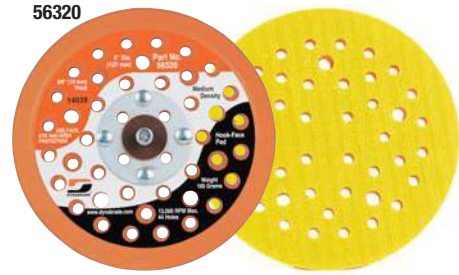

Note: All 8" pads mount with screws.

Loop-Face Sanding Pads

- Created for reverse hook 'n loop abrasives. Securely holds discs and allows for easy change and reattachment.
- Premium urethane resists heat and provides maximum durability. Weight-mated and perfectly balanced – assures performance.
- 5/16"-24 male thread fits many brands of random orbital sanders. 13,000 RPM maximum operating speed.

Part No.	Diameter	Type
56310	5"	Non-Vac
56311	5"	Vacuum
56312	6"	Non-Vac
56313	6"	Vacuum

Radius Edge Pads

- Ideal for finishing surfaces with contoured corners!
- Premium foam, soft density, rounded edge pad conforms to shape of coves and corners. 5/16"-24 Male Thread.
- Ideal for use with scalloped-edge abrasives. Scalloped edge easily conforms to rounded edge of sanding pad, allowing more abrasive to contact work surface.

57796

3-1/2" Diameter

57795

5" Diameter



6" & 8" Random Orbital and "Mud Hog" Pads

57772



57773



54333



PSA

Pad Construction	Density	6" Diameter				8" Diameter	
		Non-Vacuum	Screws	Vacuum	Screws	Non-Vacuum	Vacuum
Premium Urethane	Medium	57771	4	57772	4	56234	56235
Premium Urethane	Medium	57762	5	57763	5	-	-

Hook-Face, Short Nap

Pad Construction	Density	6" Diameter				8" Diameter	
		Non-Vacuum	Screws	Vacuum	Screws	Non-Vacuum	Vacuum
Premium Urethane	Medium	57773	4	57775	4	56236	56237
Premium Urethane	Medium	57764	5	57765	5	-	-

Hook-Face, Long Nap (For Non-Woven Nylon)

Pad Construction	Density	6" Diameter				8" Diameter	
		Non-Vacuum	Screws	Vacuum	Screws	Non-Vacuum	Vacuum
Rubber	Medium	-	-	-	-	54332	54333

Note: All 8" pads mount with screws.

11" Rotary and Random Sanding Pads

- For vacuum and non-vacuum use. Pads mount with screws.

56231

Hook-Face Pad

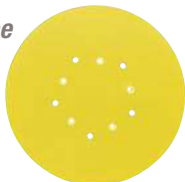

56230

PSA Pad

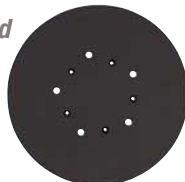

56232

Loop-Face Pad

- Accepts reverse hook 'n loop abrasive discs.



56220

Conversion Pad

- Allows attachment of reverse hook 'n loop abrasive discs to 56231 Hook-Face Pad. Non-Vacuum only.



Sanding Pads

2-3/4" Wide x 8" Long Dynaline Pads



Part No.	Type	Description
56324	Vacuum	Loop-Face
57454	Non-Vacuum	PSA
57455	Vacuum	PSA
57456	Non-Vacuum	Hook-Face "Short Nap"
57457	Vacuum	Hook-Face "Short Nap"
57471*	Non-Vacuum	Hook-Face "Long Nap"

Note: For PSA pad with clips, order 57460; uses 2-3/4" x 11" abrasive sheets.

8" Dynaline Contoured Specialty Pads

- Accepts 2-3/4" wide x 8" long PSA abrasive sheets.

57458 Curved Pad



57462 Radiused Pad



2-3/4" Wide x 11" Long Dynaline Pads

- Premium urethane pad resists heat build-up.
- For use with PSA or hook-face coated abrasives and non-woven nylon sheets or rolls.



Part No.	Density	Description
57511	Medium	PSA
57512	Medium	PSA
57513	Medium	Hook-Face "Short Nap"
57514*	Medium	Hook-Face "Long Nap"

Dynafine® Sanding Pads



Triangular Pads

Part No.	Description
57950	PSA
57951	Short-Nap, Hook-Face
57955*	Long-Nap, Hook-Face

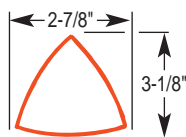

Tear-Drop Pads

Part No.	Description
57952	PSA
57953	Short-Nap, Hook-Face
57954*	Long-Nap, Hook-Face

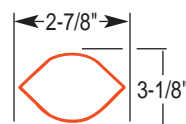

***Note:** Long Nap Pads are designed for use with non-woven nylon.

3-2/3" Wide x 7" Long Pads



Part No.	Type	Description
57850	Non-Vacuum	PSA
57851	Non-Vacuum	Hook-Face "Short Nap"
57852*	Non-Vacuum	Hook-Face "Long Nap"
57855	Vacuum	PSA
57856	Vacuum	Hook-Face "Short Nap"

Vacuum Dynafine® Sanding Pads



Part No.	Shape	Type
58045	Tear-Drop	Vinyl-Face
58048	Tear-Drop	Hook-Face
58046	Triangular	Vinyl-Face
58049	Triangular	Hook-Face
58044	Round	Vinyl-Face
58047	Round	Hook-Face

Wet Dynafine® Sanding Pads



Part No.	Diameter	Type
58025	2"	Loop-Face
58030	2"	PSA
58031	2"	Hook-Face
58026	3"	Loop-Face
58032	3"	PSA
58033	3"	Hook-Face

Sanding Pads

Dynabug® "Model T" Sanding Pads

5" Diameter

Part No.	Type	Density
56246	PSA	Soft
56249	PSA	Medium
56247	Hook-Face	Soft
56248	Hook-Face	Medium

6" Diameter

Part No.	Type	Density
56269	PSA	Medium
56287	PSA	Soft
56268	Hook-Face	Medium
56288	Hook-Face	Soft

4" W x 4-5/16" L with Clips

Part No.	Type	Density
57999	PSA	Medium

4-1/4" W x 4-1/2" L

Part No.	Type	Face Type	Density
56244	Non-Vacuum	PSA	Medium
56245	Non-Vacuum	PSA	Soft
56286	Vacuum	PSA (1/4" Thick)	Medium
56291	Vacuum	PSA (3/8" Thick)	Medium
56293	Vacuum	PSA	Soft
57996	Non-Vacuum	Hook-Face (Short Nap)	Soft
57998	Non-Vacuum	Hook-Face (Short Nap)	Medium
56292	Vacuum	Hook-Face (Short Nap)	Soft (1/4" Thick)
56294	Vacuum	Hook-Face (Short Nap)	Soft
56285	Vacuum	Hook-Face (Short Nap)	Medium (1/8" Thick)



Dynabug® II Sanding Pads

- All pads mount with 4 screws and are interchangeable.

2-3/4" W x 7-3/4" L

Part No.	Face Type	Type
56324	Loop-Face	Vacuum

3" W x 4-1/4" L

Part No.	Face Type	Type
56315	Hook-Face	Non-Vacuum
56316	Hook-Face	Vacuum
56343	Long Nap Hook-Face	Non-Vacuum
56355	PSA	Non-Vacuum
56356	PSA	Vacuum

3-1/4" W x 5" L

Part No.	Face Type	Type
56317	Hook-Face	Non-Vacuum
56318	Hook-Face	Vacuum ("4 x 4" Pattern)
56319	Hook-Face	Vacuum
56357	PSA	Non-Vacuum
56359	PSA	Vacuum

4" W x 5-3/4" L "Delta Style"

Part No.	Face Type	Type
56323	Hook-Face	Vacuum

4-1/4" W x 4-1/2" L

Part No.	Face Type	Type
56331	Hook-Face	Non-Vacuum



56323



56315



56343



56318



56319

Interface Pads and Pad Conversions

Dynafoam Interface Pads

- Soft foam increases conformability allowing operator to easily follow contours. Converts standard pad into a fine finishing and finessing pad!
- Interface pad easily contours to most surfaces.
- Attaches between hook-face sanding pad and hook 'n loop abrasive.



White printed side attaches to standard hook-face pad. 1/2" Thick Foam

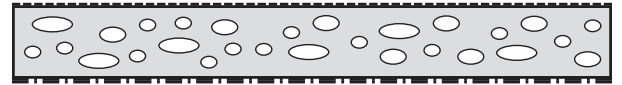

Black hook side accepts conventional hook 'n loop abrasives.

For Random Orbital Sanders Non-Vac and Vacuum Orbitals

Part No.	Diameter	
53974	3"	○
53976	3-1/2"	○
53978	5"	●●●
53980	6"	●●●●
53982	8"	●●●●●●

For Dynafine® Detail Sanders Tear Drop and Triangle

Part No.	Diameter	
53970	Tear Drop	◐
53972	Triangle	◓

For 11" Dia. Sanders "O" Style Pad

Part No.	Diameter	
53998	11"	○

For Board Sanders Dynaline and Dynabug®

Part No.	Size and Tool For Use With	
53984	2-3/4" x 11" Tool: Dynaline	□
53986	2-3/4" x 8" Tool: Dynaline	●●●
53988	3-2/3" x 7" Tools: Dynaline/Dynabug®	●●●●

PSA-To-Hook Pad Conversions

- Thin sticky-back sheet adheres to current PSA pad and accepts hook 'n loop abrasives.

Peel-off liner with sticky-back adheres to operator's current vinyl-face pad.



Hook-face material for accepting standard hook 'n loop abrasives.

For Random Orbital Sanders Non-Vac and Vacuum Orbitals

Part No.	Diameter	
53975	3"	○
53977	3-1/2"	○
53979	5"	●●●
53981	6"	●●●●
53983	8"	●●●●●●

For Dynafine® Detail Sanders Tear Drop and Triangle

Part No.	Diameter	
53971	Tear Drop	◐
53973	Triangle	◓

For Board Sanders Dynaline and Dynabug®

Part No.	Size and Tool For Use With	
53985	2-3/4" x 11" Tool: Dynaline	□
53987	2-3/4" x 8" Tool: Dynaline	●●●
53989	3-2/3" x 7" Tools: Dynaline/Dynabug®	●●●●

Hook-To-PSA Pad Conversions

- Thin velcro-backed sheet attaches to standard hook-face pad and accepts PSA abrasives.

Non-Vacuum and Vacuum Orbitals

Part No.	Diameter	
53992	5"	●●●
53993	6"	●●●●



Loop material attaches to standard hook-face sanding pad.



Premium vinyl-face for stick-on abrasives.

Point-of-Purchase Accessories

Pre-Packaged Accessories for Showroom and Will Call Areas!

Random Orbital Sander Pads

- Premium urethane random orbital sanding pads with 5/16"-24 male thread.
- Weight-mated to Dynabrade Random Orbital Sanders for low vibration!

Vinyl-Face Pads

- 76006** 5" Diameter, Vacuum
- 76007** 5" Diameter, Non-Vacuum
- 76008** 6" Diameter, Vacuum
- 76009** 6" Diameter, Non-Vacuum

Hook-Face Pads

- 76010** 5" Diameter, Vacuum
- 76011** 5" Diameter, Non-Vacuum
- 76012** 6" Diameter, Vacuum
- 76013** 6" Diameter, Non-Vacuum

Counter Displays

- Each display pack consists of ten pads in a refillable Dynabrade display box.

- 95994** 5" Diameter, Non-Vacuum
- 95995** 5" Diameter, Vacuum
- 95996** 6" Diameter, Non-Vacuum
- 95997** 6" Diameter, Vacuum



Individual Pad



Counter Display

Buffing Pad Packages

All Pads 3,200 RPM M.O.S.

76000 Buffing Kit

- Includes one of each:
 - 3" Terry Cloth Pad (90027)
 - 3" Wool Pad (90028)
 - 3" White "Polishing" Foam Pad (90038)
 - 3" Yellow "Cutting" Foam Pad (90044)
 - 3" Hook-Face Pad Backing (50125)
 - 1/4" Shank (50103)

76014 Terry Cloth Buffing Pads

- Includes four pads.

76015 Wool Buffing Pads

- Includes four pads.

76016 Foam "Polishing" Pads

- Includes four white "polishing" buff pads.

76017 Foam "Cutting" Pads

- Includes four yellow "cutting" buff pads.



Point-of-Purchase Accessories

Pre-Packaged Accessories for Showroom and Will Call Areas!

DynaZip Accessories

92255 RED-TRED® Eraser Wheel

- For removal of vinyl graphics.
- 4" diameter x 1-1/4" wide.
- For use with Dynabrade 92284 Wheel Hub Assembly.

92257 RED-TRED® Eraser Wheel & Hub (Not Shown)

- For use on DynaZip Surface Preparation Tool.

92295 RED-TRED® Eraser Disc Assembly

- For use on RED-TRED® Eraser Disc Tools.

76001 DynaZip Wire Wheel

- 4" dia. x 3/4" wide
- Ideal for removing paint, rust and sealants.
- Coarse Grade with Bent Tip Wire.
- Ideal for use with Dynabrade DynaZip Air Tool.



92255



92295



76001



61374

Random Orbital Head Kit

61374

- Unique random orbital motion minimizes “haze” and “halo” effects, while reducing “burn through” of top coats and sealants.

Cut & Polish Rotary/Random Orbital Head

61384

- Run pad in rotary (cut) mode for initial buffing and removing dust nibs, light scratches, oxidation and “orange peel.” Then switch to random orbital (polish) mode for buffing to a swirl-free finish with no “haze” or “halo” effects!



61384



93889

DynaMitt Accessories

58005 DynaMitt Sanding Glove

- Palm side of DynaMitt accepts hook face abrasive sheets.
- Conforms to surfaces. Put sanding in the palm of your hand!

93889 DynaMitt Abrasive Sheets

- Sample abrasives kit, including coated and non-woven nylon sheets.

Dynabrade Lubri-Pak

76020

- Includes 10 oz. tube of multi-purpose grease, push-type gun and 4 oz. bottle of Dynabrade air tool oil.
- Convenient kit for tools with gears – tool maintenance made easy!
- Air lube prevents formation of contamination build-up.
- Grease suitable for bearings, cams, gears, etc.



76020



96101

Dynabrade Air Lube Display Box

96101

- (24) 4 oz. bottles (95821).
- Highly recommended in use of all Dynabrade tools.
- Absorbs up to 10% of its weight in water.

Point-of-Purchase Air Line Accessories

Pre-Packaged Accessories for Showroom and Will Call Areas!

Lightweight 8mm I.D. Air Line Assembly

- Air line is 66% lighter than conventional hoses.
- High flexibility and narrow bending prevents choking.
- Includes one male and one female fitting.

76018 5 ft. Length

76019 2 ft. Length

76018



Dynaswivel® Air Line Connector

Never Fight an Air Hose Again!

- Dynaswivel® rotates 360° at two locations allowing air hose to drop straight to the floor, no matter how the tool is held.
- 1/4" NPT.

94300 Non-Marring Composite Construction

95460 Aluminum Construction

94300



96177

Dynaswivel® Store Counter Display Pack

96177

- Ten 94300 1/4" NPT Dynaswivel® Air Line Connectors in a refillable display box.
- Convenient way to buy!

Coupler and Plug Sets

76004 Push-Button Quick Coupler and Plug Set

- Lightweight 1.4 oz, non-marring composite material.
- Heavy-duty construction.
- 1/4" Female Coupler to 1/4" Male Plug.

76005 Pull-Back Steel and Brass Coupler/Plug Set

- Durable nickel-plated steel and brass construction.
- Pull back on sleeve of coupler for quick disconnect of tool from air line.
- 1/4" Female Coupler to 1/4" Male Plug.



76004



76005

DynaJet In-Line Blow Guns

- Purges air lines of water and contaminants before starting air tool.
- Clean off work pieces after grinding and sanding.
- Meets O.S.H.A. requirements which limits air pressure to 30 PSIG.

76003 DynaJet In-Line Blow Gun with Safety Tip

76002 Standard DynaJet In-Line Blow Gun



76003



76002

Dynabrade Product Information

Tool Maintenance Is Important

Air tools do require maintenance to keep them running in tip-top shape. Problems can occur if maintenance is not performed. Moisture can gather in air lines and be blown into air tools during use.

Motor lubrication is necessary. Greater performance and longevity of air tools can be expected with the use of a filter-regulator-lubricator. A clean, dry, air source and proper lubrication with a good-grade non-detergent oil (such as Dynabrade Air Lube on page 41) is a preventative measure that will go a long way – and potentially save on costly repairs.

Run Dynabrade air tools at 90 PSI or less, unless otherwise specified. Running the tools at higher pressures can be the cause of unnecessary premature wear and can contribute to an unsafe condition.

Customer Service

Dynabrade's customer service staff has one very important job – to make sure that you are completely satisfied with your order. Our service department is staffed with highly-trained people, ready to serve you in any way they can, from technical advice and order taking to rush shipments.

Dynabrade Tools Meet the Following High Quality Standards

Ergonomics and operator comfort have worked their way into each Dynabrade air tool design. Factors including Vacuum, Vibration, Insulation and Sound are addressed at every integral design stage. These factors are critical to our research and development of new products as we continue to meet the needs of the marketplace.

➤ VACUUM

Airborne sanding particles can cause severe inflammation of the eyes and lung tissue, varying on the degree of exposure and the type of airborne contaminants involved. It is because of this danger that Dynabrade manufactures self-generated and central vacuum tools that direct airborne particles away from the operator, air motor and work surfaces.

➤ VIBRATION

All hand-held machines transmit vibration to an operator's hand while in operation. Operators that work with vibrating machines for extended periods of time risk many different types of injury. The main types of injuries that are likely to occur are vascular injury, nerve injury, skeletal injury and joint injury. To help reduce vibration, we have built features into our tools that include composite housings, rubber overmolds and insulated handles.

➤ INSULATION

Cold caused by pneumatic-powered tools can cause a variety of work-related injuries. Dynabrade manufactures a variety of tools with thermal-insulated housings to reduce cold air transmission to the operator, reducing the risk of whitefinger disease and other injury-related symptoms.

➤ SOUND

High sound levels over an extended period of time can damage hearing. New enhancements to muffling systems, exhaust protection and other tool design factors further reduce tool sound levels in the workplace.

TECH TIP – Air Consumption

“Air Consumption” is an averaged maximum rating, recorded at free speed on non-governed tools and at maximum horsepower on governed tools, and expressed in SCFM (Standard Cubic Feet Per Minute). Dynabrade adheres to this standard of measurement. It is usually sufficient to directly compare the tool's SCFM consumption with the compressor's inlet CFM rating to determine if and how many tools a particular compressor will run. Depending on the duty cycle of the tool, storage tanks may allow a compressor to run a tool that has a larger consumption than the compressor has output. **NOTE:** Some manufacturers may present air consumption figures using ACFM (Actual Cubic Feet Per Minute), which is the “flow rate of air measured at a given reference point at the given pressure.” This enables these manufacturers to seemingly gain a competitive advantage, although SCFM is the accepted term that most manufacturers (including Dynabrade) use. Typical airflow for a random orbital sander is 15 SCFM (2.1 CFM @ 90 PSIG). If a tool user compares the 15 SCFM of consumption to the compressor inlet CFM directly (1:1), proper sizing will occur. If the 2.1 CFM rating is compared directly to the compressor's inlet CFM rating, the compressor may be drastically undersized. As a consumer, one should question any tools that claim to produce high horsepower with unusually low air consumption and/or weigh much less than Dynabrade models!

Air Tool & System Performance Assurance

AIR TOOL INSPECTION

Inspect the air tool.



Is the tool's air inlet clean?



Is the tool's exhaust (muffler/silencer) clean?



Has the motor been oiled?

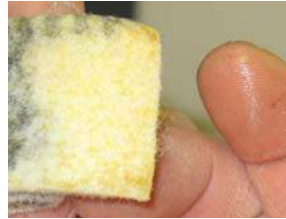

This silencer shows evidence of oil.



This air motor received "Last-Rites Oil."

Notice, the puddle of oil appears clean.

Can the tool's spindle be turned by hand?



"The spindle won't turn." This usually indicates broken vanes.

Generally, broken vanes indicate that the motor has not been oiled regularly.

AIR SYSTEM CHECK

Tachometer

- Affix a 1/2" (12 mm) square piece of reflective tape to the tool's spindle or pad.
- Aim the Laser Pointer at the reflective tape and run the tool. (Operational distance: 2"/50 mm to 20"/500 mm)
- Read RPM. (Notice: Refer to User's Manual for more detailed instructions.)

PSI Gauge

- Connect Air Gauge and air supply hose to the air inlet of the tool.
- Run the tool and adjust air supply pressure to 90 PSIG (6.2 Bar).

Condition of Coupler and Plug

- Check for wear or damage to coupler and/or plug.
- Can the I.D. of the plug supply enough air to the tool?

Condition of Air Hose

- Check to see if the hose is frayed or cracked? (see "Cost of an Air Hose Leak" on reverse side)
- What is the length of the hose?
- Match length and I.D. of hose to air requirement of tool.
- Is there a hose reel?

Condition of Air Hose (Continued)

- How many coupler connections exist from the drop to the workbench?
- Are there any "T's" or a manifold at the workbench?
- How can Dynaswivel® prolong the life of the hose?

Filter-Regulator-Lubricator

- FRL – is it present? If yes, is it working?
- Filled with oil? Set for proper lubrication?
- What type of oil? (Weight, Non-detergent vs. Detergent – Notice: Non-detergent oils contain little to no solvents. Air Tool Oils with "conditioner" usually contain solvents. Example: Both Marvel® Air Tool Oil and Marvel® Mystery Oil contain mineral spirits, a common solvent used as paint thinner.)
- Are there reducer bushings being used to connect the air supply to the FRL?
- What size is the fitting connecting the FRL to the air line that is supplying the air to the workbench?
- Are there any "T's" or manifolds coming directly off the FRL?
- What material is the pipe that is carrying the air supply? Black Iron?



AIR SUPPLY HOSE RECOMMENDATIONS

Air Motor SCFM	Hose and Fitting I.D.	Recommended Length
22 (623 LMP)	1/4"	1' - 8'
28 (793 LMP)	3/8"	1' - 25'
35 (991 LMP)	3/8"	1' - 20'
45 (1274 LMP)	3/8"	1' - 10'
73 (2067 LMP)	1/2"	1' - 20'

RANDOM ORBITAL SANDER SWIRL-FREE CHECKLIST

Equipment Check:

Random Orbital Sander

- 90 PSIG (6.2 Bar) is the required operating air supply pressure.** Check the air pressure at the sander while it is running. Note: Promote the use of Dynabrade maximum flow plugs and couplers to ensure proper airflow.
- Confirm that the tool is running at the rated "Free Speed" RPM.** On an average a 10,000 RPM non-vacuum sander will run at 9,500 RPM; a 12,000 RPM non-vacuum sander will run at 11,500 RPM. A vacuum sander normally runs slightly slower.
- Inspect the balancer bearing (pad bearing).** Remove the back-up pad and rotate the balancer bearing shaft while holding the counterbalance stationary. The balancer shaft should turn freely.



Back-Up Pad

- Inspect the face of the sanding pad.** The pad must be flat and smooth, without any defects. Check if they are using a Dynabrade back-up pad that is "weight-mated" to the sander. Using another pad can make the sander vibrate excessively and lead to an unacceptable finish.

Sanding Techniques:

- Always START the sander ON the surface, and STOP the sander OFF the surface.**
- When sanding keep the sander, and pad FLAT on the surface.**
Important: Do not exert heavy downward force on the sander. Apply enough downward force to keep the back-up pad and abrasive flat on the surface allowing the back-up pad to orbit freely over the surface.

Sanding Techniques (Continued)

- Follow a set pattern when sanding.** It is suggested to pass over the surface following a "North, South, East, West" pattern (see below), overlapping each pass 1/4 the diameter of the back-up pad and abrasive. This insures that the previous scratches are removed and that a uniform finish is achieved. Two "patterns" per sanding step are recommended.

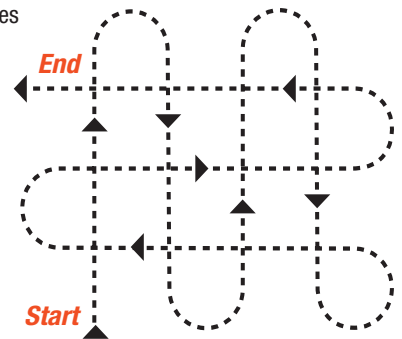

- Frequently inspect abrasive for tears, folds, or build-up.** When changing abrasive to proceed to the next sanding step, first inspect the condition of the abrasive that is on the sander. If any defects are noticed in that abrasive, remove it and install another piece of the same grain and sand the work surface again before proceeding on to the next sanding step.
- Always clear away sanding dust and abrasive debris before progressing to the next sanding step with a finer "grit" abrasive.**

THE COST OF AN AIR HOSE LEAK

One 1/16" hole in a hose leaks at 100 PSIG:

- 4.25 cubic feet per minute (CFM)
- 255 cubic feet per hour
- 2,040 cubic feet in an 8-hour day
- 6,120 cubic feet per 24 hours

*Costs will vary based on local charges per kilowatt-hour.

PLUG CONNECTORS

Compare Airflow SCFM (LPM)

All information based upon size of I.D. at 90 PSIG (6.2 Bar) in conjunction with mating coupler.



Common Plug Connector
25 SCFM (708 LPM)



Dynabrade Plug Connector
76 SCFM (2,152 LPM)

Numerical Index of Tools

Model	Description	Page No.	Model	Description	Page No.
10127	3" Dynabuffer w/Hanger Bracket, 7,000 RPM	26	10735	6" Two-Hand Dynorbital® R.O. Sander 12,000 RPM, 3/8" Dia. Orbit (Central Vac).....	11
10170	Dynabug® Sander with 3/32" Orbit (Non-Vac)	20	10745	5" Dynabuffer w/Hanger Bracket, 10,000 RPM	26
10174	Dynabug® Sander with 3/32" Orbit (Central Vac-Ready).....	20	10750	5" DynaLocke® 12,000 RPM (Non Vac)	15
10280	Dynabug® II (Non-Vac).....	20	10752	5" DynaLocke® 12,000 RPM (Basic Vac)	15
10282	Dynabug® II (Central Vac-Ready)	20	10754	6" DynaLocke® 12,000 RPM (Non-Vac)	15
10283	Dynabug® II (Non-Vac).....	20	10756	6" DynaLocke® 12,000 RPM (Basic Vac)	15
10285	Dynabug® II (Central Vac-Ready)	20	10760	6" "Mud Hog" Gear Driven Sander 900 RPM (Non-Vac)	13
10288	Wet "Model T" 5" w/Hook Pad	17	10761	6" "Mud Hog" Gear Driven Sander 900 RPM w/57772 Pad (Central Vac-Ready)	13
10289	Wet "Model T" 6" w/Hook Pad	17	10763	8" "Mud Hog" Gear Driven Sander 900 RPM (Non-Vac)	13
10341	3-1/2" Wet Dynorbital® Supreme ROS	18	10764	8" "Mud Hog" Gear Driven Sander 900 RPM (Central Vac-Ready)	13
10343	5" Wet Dynorbital® Supreme ROS	18	10770	3" DynaLocke® 12,000 RPM (Non Vac)	15
10345	6" Wet Dynorbital® Supreme ROS	18	10771	3" DynaLocke® 12,000 RPM (Self-Gen Vac-Ready)	15
10350	3-1/2" Dynorbital® Scrubber 10,000 RPM	22	10780	3-1/2" DynaLocke® 12,000 RPM (Non-Vac).....	15
10351	3-1/2" 3/32" Dia. Orbit Wet Dynorbital® Supreme	18	10781	3-1/2" DynaLocke® 12,000 RPM (Self-Gen Vac-Ready)	15
10353	5" - 3/32" Dia. Orbit Wet Dynorbital® Supreme	18	10786	8" Random Orbital Buffer (3/4" Orbit)	25
10354	6" - 3/32" Dia. Orbit Wet Dynorbital® Supreme	18	10789	RED-TRED® Heavy-Duty Eraser Disc Tool	32
10360	1-1/4" Mini-Dynorbital® Sander 5,000 RPM Palm-Style.....	6	10800	Dynafine® Detail Sander	27
10390	3" Buffer 2,400 RPM Palm-Style	23	10810	Dynafine® Detail Sander Versatility Kit	27
10393	3" Buffer Sander Versatility Kit 2,400 RPM Palm-Style	23	10820	Dynafine® Finger Sander	27
10398	4 - 5" Palm-Buffer 2,400 RPM Palm-Style.....	23	10821	Dynafine® Finger Sander Versatility Kit.....	27
10400	Dynaline Sander (Non-Vac)	21	10843	DynaPen Filer, 1/8" Collet	31
10404	Dynaline Sander (Cen Vac-Ready)	21	10844	DynaPen Filer Versatility Kit	31
10470	"Model T" Sheet Sander w/57999 Pad	16	10880	Wet Dynafine®	19
10472	"Model T" Sheet Sander w/57998 Pad	16	15003	Mini-Dynafine® II Abrasive Belt Tool	29
10475	"Model T" 5" Round w/56249 Pad.....	16	15006	Mini-Dynafine® II Versatility Kit.....	29
10477	"Model T" 5" Round w/56248 Pad.....	16	18000	Mini Straight-Line Die Grinder, 25,000 RPM, 1/4" Collet	34
10479	"Model T" Sheet Sander w/56244 Pad	16	18001	Mini Straight-Line Die Grinder, 25,000 RPM, 6 mm Collet	34
10481	"Model T" 6" Round w/ 56269 Pad	16	18010	Mini Right-Angle Die Grinder, 20,000 RPM, 1/4" Collet	34
10483	"Model T" 6" Round w/ 56268 Pad	16	18015	Mini Right-Angle Die Grinder/Disc Sander Kit	34
10485	"Model T" w/Vinyl Pad Central Vac	16	18020	Die Grinder, 20,000 RPM, 1/4" Collet.....	34
10487	"Model T" w/Hook Pad Central Vac	16	18025	"Four Tools In One" Versatility Kit.....	31
10540	11" File Board Sander	22	18050	5" - 8" Dia. Buffer	36
10541	11" File Board Sander Kit	22	18055	3" Dia. Buffer (3/8"-24 male spindle)	36
10710	5" Two-Hand Dynorbital® R.O. Sander 12,000 RPM, 3/16" Dia. Orbit (Non-Vac).....	11	18056	3" Buffer, 3,200 RPM.....	36
10712	5" Two-Hand Dynorbital® R.O. Sander 12,000 RPM, 3/16" Dia. Orbit (Basic Vac)	11	18058	3" Dia. Buffer/Sander Kit	36
10720	6" Two-Hand Dynorbital® R.O. Sander 12,000 RPM, 3/16" Dia. Orbit (Non Vac)	11	18066	File Board, 2-3/4" x 17-1/2"	35
10722	6" Two-Hand Dynorbital® R.O. Sander 12,000 RPM, 3/16" Dia. Orbit (Basic Vac)	11	18067	RED-TRED® Eraser Disc Tool	32
10724	6" Two-Hand Dynorbital® R.O. Sander 12,000 RPM, 3/16" Dia. Orbit (Central Vac).....	11	18068	3" Pistol-Grip Buffer	32
10725	8" Two-Hand Dynorbital® R.O. Sander 10,000 RPM, 3/16" Dia. Orbit (Non Vac)	11	18069	Pistol-Grip RED-TRED® Eraser Disc Tool.....	32
10727	8" Two-Hand Dynorbital® R.O. Sander 10,000 RPM, 3/16" Dia. Orbit (Basic Vac)	11	18071	Pistol-Grip RED-TRED® Eraser Disc/Buffering Versatility Kit.....	32
10729	8" Two-Hand Dynorbital® R.O. Sander 10.000 RPM, 3/16" Dia. Orbit (Central Vac).....	11	18075	3" Extension Cut-Off Wheel Tool	35
10730	5" Two-Hand Dynorbital® R.O. Sander 12,000 RPM, 3/8" Dia. Orbit (Non Vac)	11	18080	3" Dia. 7° Offset Cut-Off Wheel Tool	35
10731	5" Two-Hand Dynorbital® R.O. Sander 12,000 RPM, 3/8" Dia. Orbit (Basic Vac)	11	18100	3/4" Auto File II Belt Tool.....	31
10733	6" Two-Hand Dynorbital® R.O. Sander 12,000 RPM, 3/8" Dia. Orbit (Non Vac)	11	18160	2" Dia., 7° Disc Sander	35
10734	6" Two-Hand Dynorbital® R.O. Sander 12,000 RPM, 3/8" Dia. Orbit (Basic Vac)	11	18180	3" Dia., 7° Disc Sander	35
			18253	DynaZip (Tool Only, No Accessories).....	33
			18255	DynaZip Air Tool.....	33
			18256	DynaZip Air Tool Kit	33
			18258	DynaZip Eraser Decal Removal Air Tool	33
			21000	3" Dynorbital-Spirit® ROS (Non-Vac)	5
			21001	3" Dynorbital-Spirit® ROS (Basic-Vac)	5
			21004	3" Dynorbital-Spirit® ROS (Central Vac-Ready).....	5
			21005	3-1/2" Dynorbital-Spirit® ROS (Non-Vac)	5
			21006	3-1/2" Dynorbital-Spirit® ROS (Basic-Vac)	5

Numerical Index of Tools

Model	Description	Page No.	Model	Description	Page No.
21009	3-1/2" Dynorbital-Spirit® ROS (Central Vac-Ready)	5	52335	Die Grinder 25,000 RPM .4 hp 7° Right Angle Rear Exhaust	28
21010	5" Dynorbital-Spirit® ROS (Non-Vac)	5	52337	Die Grinder 30,000 RPM .4 hp 7° Right Angle Rear Exhaust	28
21011	5" Dynorbital-Spirit® ROS (Basic-Vac)	5	52420	3" Dia., .5 Hp 7° Right Angle Cut-Off Front Exhaust.....	28
21014	5" Dynorbital-Spirit® ROS (Central Vac-Ready).....	5	52503	2" Disc Sander 25,000 RPM .4 hp 7° Rear Exhaust.....	28
21015	6" Dynorbital-Spirit® ROS (Non-Vac)	5	52836	1/4" Drill, .4 hp, 20,000 RPM, Pistol-Grip, DynaChuck	28
21016	6" Dynorbital-Spirit® ROS (Basic-Vac)	5	57502	Mini-Dynorbital® ROS (Locking-Type Pad)	26
21019	6" Dynorbital-Spirit® ROS (Central Vac-Ready).....	5	57800	Dynabug® Orbital Sander with 3/16" Orbit (Non-Vac).....	20
21020	3" Dynorbital-Spirit® ROS (Non-Vac)	5	57804	Dynabug® Orbital Sander with 3/16" Orbit (Central Vac-Ready)	20
21021	3" Dynorbital-Spirit® ROS (Basic-Vac)	5	58040	11" Gear-Driven Mud Hog Sander (Non-Vac)	14
21024	3" Dynorbital-Spirit® ROS (Central Vac-Ready).....	5	58041	11" Gear-Driven Mud Hog Sander (Central Vac-Ready)	14
21025	3-1/2" Dynorbital-Spirit® ROS (Non-Vac)	5	58480	11" Random Orbital Sander (Non-Vac).....	12
21026	3-1/2" Dynorbital-Spirit® ROS (Basic-Vac)	5	58485	11" Random Orbital Sander (Central Vac-Ready)	12
21029	3-1/2" Dynorbital-Spirit® ROS (Central Vac-Ready)	5	69000	3-1/2" Dynorbital® Silver Supreme ROS (Non-Vac)	9
21030	5" Dynorbital-Spirit® ROS (Non-Vac)	5	69003	3-1/2" Dynorbital® Silver Supreme ROS (Basic-Vac)	9
21031	5" Dynorbital-Spirit® ROS (Basic-Vac)	5	69004	3-1/2" Dynorbital® Silver Supreme ROS (Central Vac-Ready)	9
21034	5" Dynorbital-Spirit® ROS (Central Vac-Ready).....	5	69005	5" Dynorbital® Silver Supreme ROS (Non-Vac).....	9
21035	6" Dynorbital-Spirit® ROS (Non-Vac)	5	69008	5" Dynorbital® Silver Supreme ROS (Basic-Vac).....	9
21036	6" Dynorbital-Spirit® ROS (Basic-Vac)	5	69009	5" Dynorbital® Silver Supreme ROS (Central Vac-Ready)	9
21039	6" Dynorbital-Spirit® ROS (Central Vac-Ready).....	5	69010	6" Dynorbital® Silver Supreme ROS (Non-Vac).....	9
21040	3" Dynorbital-Spirit® ROS (Non-Vac)	5	69013	6" Dynorbital® Silver Supreme ROS (Basic-Vac).....	9
21041	3" Dynorbital-Spirit® ROS (Basic-Vac)	5	69014	6" Dynorbital® Silver Supreme ROS (Central Vac-Ready)	9
21044	3" Dynorbital-Spirit® ROS (Central Vac-Ready).....	5	69015	3-1/2" Dynorbital® Silver Supreme ROS (Non-Vac)	9
21045	3-1/2" Dynorbital-Spirit® ROS (Non-Vac)	5	69018	3-1/2" Dynorbital® Silver Supreme ROS (Basic-Vac)	9
21046	3-1/2" Dynorbital-Spirit® ROS (Basic-Vac)	5	69019	3-1/2" Dynorbital® Silver Supreme ROS (Central Vac-Ready)	9
21049	3-1/2" Dynorbital-Spirit® ROS (Central Vac-Ready)	5	69020	5" Dynorbital® Silver Supreme ROS (Non-Vac).....	9
21050	5" Dynorbital-Spirit® ROS (Non-Vac)	5	69023	5" Dynorbital® Silver Supreme ROS (Basic-Vac).....	9
21051	5" Dynorbital-Spirit® ROS (Basic-Vac)	5	69024	5" Dynorbital® Silver Supreme ROS (Central Vac-Ready)	9
21054	5" Dynorbital-Spirit® ROS (Central Vac-Ready).....	5	69025	6" Dynorbital® Silver Supreme ROS (Non-Vac).....	9
21055	6" Dynorbital-Spirit® ROS (Non-Vac)	5	69028	6" Dynorbital® Silver Supreme ROS (Basic-Vac).....	9
21056	6" Dynorbital-Spirit® ROS (Basic-Vac)	5	69029	6" Dynorbital® Silver Supreme ROS (Central Vac-Ready)	9
21059	6" Dynorbital-Spirit® ROS (Central Vac-Ready).....	5	69030	3-1/2" Dynorbital® Silver Supreme ROS (Non-Vac)	9
21060	6" Dynorbital-Spirit® ROS w/54327 Pad (Non-Vac)	5	69033	3-1/2" Dynorbital® Silver Supreme ROS (Basic-Vac)	9
21061	6" Dynorbital-Spirit® ROS w/54327 Pad (Non-Vac)	5	69034	3-1/2" Dynorbital® Silver Supreme ROS (Central Vac-Ready).....	9
21062	6" Dynorbital-Spirit® ROS w/54327 Pad (Non-Vac)	5	69035	5" Dynorbital® Silver Supreme ROS (Non-Vac).....	9
21063	6" Dynorbital-Spirit® ROS w/54328 Pad (Central Vac-Ready)	5	69038	5" Dynorbital® Silver Supreme ROS (Basic-Vac).....	9
21064	6" Dynorbital-Spirit® ROS w/54328 Pad (Central Vac-Ready)	5	69039	5" Dynorbital® Silver Supreme ROS (Central Vac-Ready)	9
21065	6" Dynorbital-Spirit® ROS w/54328 Pad (Central Vac-Ready)	5	69040	6" Dynorbital® Silver Supreme ROS (Non-Vac).....	9
21068	3" HiVac Dynorbital-Spirit®	7	69043	6" Dynorbital® Silver Supreme ROS (Basic-Vac).....	9
21069	3" HiVac Dynorbital-Spirit®	7	69044	6" Dynorbital® Silver Supreme ROS (Central Vac-Ready)	9
21070	3" HiVac Dynorbital-Spirit®	7	69060	6" Dynorbital® Silver Supreme ROS w/54327 Pad (Non-Vac)	9
21071	3" HiVac Dynorbital-Spirit®	7	69061	6" Dynorbital® Silver Supreme ROS w/54327 Pad (Non-Vac)	9
21080	Bodyman Kit - Includes 21035 6" Dynorbital-Spirit®, 18010 1/4" Die Grinder.....	6	69062	6" Dynorbital® Silver Supreme ROS w/54327 Pad (Non-Vac)	9
40260	Electric Depressed Center Wheel Grinder.....	30	69100	3" Dynorbital® Silver Supreme ROS (Non-Vac).....	9
40610	Electric Dynafine® II Abrasive Belt Tool	30	69103	3" Dynorbital® Silver Supreme ROS (Basic-Vac).....	9
40611	Electric Dynafine® II Versatility Kit	30	69104	3" Dynorbital® Silver Supreme ROS (Central Vac-Ready)	9
50321	4-1/2" - 5" Disc Sander 11,000 RPM .7 hp Pistol Grip Rear Exhaust	28	69105	3" Dynorbital® Silver Supreme ROS (Non-Vac).....	9
50324	4" Disc Sander 11,000 RPM .7 hp Pistol Grip Rear Exhaust.....	28	69108	3" Dynorbital® Silver Supreme ROS (Basic-Vac).....	9
50815	Dynafine® Detail Sander (Self-Generated Vac)	27	69109	3" Dynorbital® Silver Supreme ROS (Central Vac-Ready)	9
50817	Dynafine® Detail Sander (Central Vac-Ready).....	27	69110	3" Dynorbital® Silver Supreme ROS (Non-Vac).....	9
51400	3" 3,200 RPM .3 hp 7° Buffer	29	69113	3" Dynorbital® Silver Supreme ROS (Basic-Vac).....	9
51401	3" 5,000 RPM .3 hp 7° Buffer	29	69114	3" Dynorbital® Silver Supreme ROS (Central Vac-Ready)	9
51430	5" 3,200 RPM .3 hp 7° Buffer	29	69503	Palm-Style Mini-Dynorbital® Silver Supreme ROS	10
51580	7" - 8" Electric Rotary Buffer.....	24			
51582	11" Electric Random Orbital Sander (Non-Vac)	12			
51583	11" Electric Random Orbital Sander (Central Vac-Ready).....	12			
51584	8" Electric Random Orbital Buffer	25			