

Dynafile®

For Serial No. 4A1000 and Higher

Air Tool Manual – Safety, Operation and Maintenance

SAVE THIS DOCUMENT, EDUCATE ALL PERSONNEL

Models:

14000 – 20,000 RPM

14010 – Versatility Kit



⚠ WARNING

Read and understand this tool manual before operating your air tool. Follow all safety rules for the protection of operating personnel as well as adjacent areas. Always operate, inspect and maintain this tool in accordance with the American National Safety Institute (ANSI) Safety Code for Portable Air Tools – B186.1. For additional safety information, refer to Safety Requirements for the Use, Care and Protection of Abrasive Wheels – ANSI B7.1, Code of Federal Regulation – CFR 29 Part 1910, European Committee for Standards (EN) Hand Held Non-Electric Power Tools – Safety Requirements and applicable State and Local Regulations.

SAFETY LEGEND

	⚠ WARNING Read and understand tool manual before work starts to reduce risk of injury to operator, visitors, and tool.	⚠ WARNING Practice safety requirements. Work alert, have proper attire, and do not operate tools under the influence of alcohol or drugs.	
	⚠ WARNING Eye protection must be worn at all times, eye protection to conform to ANSI Z87.1.	⚠ WARNING Ear protection to be worn when exposure to sound, exceeds the limits of applicable Federal, State or local statutes, ordinances and/or regulations.	
	⚠ WARNING Respiratory protection to be used when exposed to contaminants that exceed the applicable threshold limit values required by law.	⚠ WARNING Air line hazard, pressurized supply lines and flexible hoses can cause serious injury. Do not use damaged, frayed or deteriorated air hoses and fittings.	

SAFETY INSTRUCTIONS

Carefully Read all instructions before operating or servicing any Dynabrade® Abrasive Power Tool.

Products offered by Dynabrade are not to be modified, converted or otherwise altered from the original design without expressed written consent from Dynabrade, Inc.

Tool Intent: Dynafile® abrasive belt machine replaces tedious hand filing and sanding and can be used for grinding, deburring, blending and polishing. Tool can be used on most materials including metal, plastic, fiberglass, composites, rubber, glass and stone.

Do not use tool for anything other than its intended applications.

This power tool is not intended for use in potentially explosive atmospheres and is not insulated against contact with electrical power.

Training: Proper care, maintenance, and storage of your tool will maximize its performance.

- Employer's Responsibility – Provide Dynafile® operators with safety instructions and training for safe use of tools and accessories.

Accessory Selection:

- Abrasive/accessory RPM (speed) rating MUST be approved for AT LEAST the tool RPM rating.
- Before mounting an accessory, visually inspect for defects. Do not use defective accessories.
- Mount only recommended accessories. See manual and Dynabrade catalog.
- Follow tool specifications before choosing size and type of accessory.
- Only use recommended fittings and air line sizes. (See tool Machine Specifications table.)

OPERATING INSTRUCTIONS

Warning: Always wear eye protection. Operator of tool is responsible for following: accepted eye, face, respiratory, hearing and body protection.

Caution: Hand, wrist and arm injury may result from repetitive work, motion and overexposure to vibration.

- Only use recommended fittings and air line sizes. Air supply hoses and air hose assemblies must have a minimum working pressure rating of 150 PSIG (10 Bars, g) or 150 percent of the maximum pressure produced in the system, whichever is higher. (See tool Machine Specifications table.)

(continued on next page)

OPERATING INSTRUCTIONS (continued)

- Keep hand and clothing away from working end of the air tool.
- Be sure that any loose clothing, hair and all jewelry is properly restrained.
- Secure inlet bushing on air tool with a wrench before attempting to install the air fitting to avoid damaging housing assembly.
- Check tool RPM (speed) with tachometer with air pressure set at 90 PSIG while the tool is running. If tool is operating at a higher speed than the RPM marked on the tool housing, or operating improperly, the tool must be serviced and corrected before use.

Caution: Tool RPM must never exceed abrasive/accessory RPM rating. Check accessory manufacturer for details on maximum operating speed or special mounting instructions.

- Disconnect air hose from tool when changing belts and contact arms.
- Connect air tool to power source. Be careful NOT to depress throttle lever in the process. **Do not expose air tool to inlet pressure above 90 PSIG or (6.2 Bars).**

Caution: After installing the accessory, before testing or use and/or after assembling tool, the Dynafile® must be started at a reduced speed to check for good balance. Gradually increase tool speed. DO NOT USE if tool vibration is excessive. Correct cause, and retest to insure safe operation.

- Make sure that work area is uncluttered, and visitors are at a safe range from the tools and debris.
- Use a vise or clamping device to hold work piece firmly in place.
- Do not apply excessive force on tool or apply "rough" treatment to it.
- Always work with a firm footing, good posture and proper lighting.
- Make sure that work area is uncluttered, and visitors are at a safe range from the tools and debris. Potentially explosive atmospheres can be caused by dust and fumes resulting from sanding or grinding. Always use dust extraction or suppression systems which are suitable for the material being processed.

Report to your supervisor any condition of the tool, accessories, or operation you consider unsafe.

Contact Arm Assembly/Disassembly Instructions

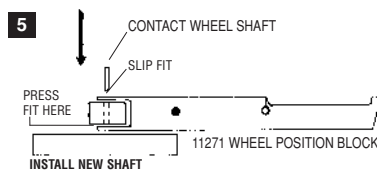
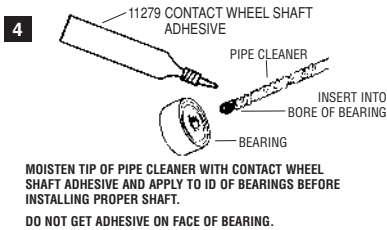
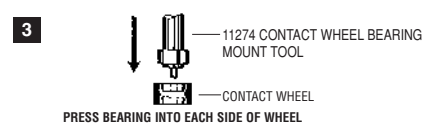
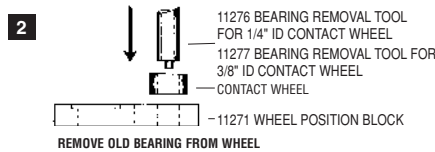
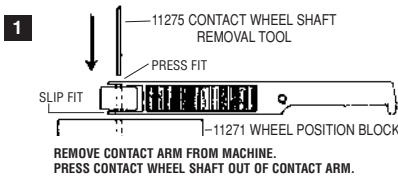

Abrasive Belt Exchange Instructions



With your thumb, pull and slide guard open in a clockwise direction.



Form a loop in belt keeping the belt splice between fingers as shown in photo above. Slip lower loop of belt under the drive wheel.



Depress idler arm lever and pull belt toward the contact wheel.



Slip belt over contact wheel. Release idler arm lever. Operate on the contact wheel or on the return side of the belt.



Completely close the guard.

Maintenance Instructions

Important: A Preventative Maintenance Program is recommended whenever portable power tools are used.

- Use only genuine Dynabrade replacement parts to insure quality. To order replacement parts, specify **Model #, Serial # and RPM** of your air tool.
- It is strongly recommended that all Dynabrade rotary vane air tools be used with a Filter-Regulator-Lubricator to minimize the possibility of misuse due to unclean air, wet air or insufficient lubrication. Dynabrade recommends the following: **11405** Air Filter-Regulator-Lubricator (FRL) – Provides for air pressure regulation, two stage filtration of water and contaminants. Operates 40 SCFM/1,133 LPM @ 100 PSIG with 3/8" NPT female ports.
- Dynabrade recommends one drop of air lube per minute for every 10 SCFM (example: if the tool specification states 40 SCFM, set the drip rate on the filter-lubricator to 4 drops per minute). Dynabrade Air Lube (P/N **95842**: 1 pt 473 ml) is recommended.

Routine Preventative Maintenance: Check free speed of Dynafire® using a tachometer.

- Mineral spirits are recommended when cleaning the tool and parts. Do not clean tool or parts with any solvents or oils containing acids, esters, ketones, chlorinated hydrocarbons or nitro carbons.
- **DO NOT** clean or maintain tools with chemicals that have a low flash point (example: WD-40®).
- A Motor Tune-Up Kit (P/N **95600**) is available which includes high wear and medium wear motor parts.
- Air tool labels must be kept legible at all times, if not, reorder label(s) and replace. User is responsible for maintaining specification information i.e.: Model #, S/N, and RPM. (See Assembly Breakdown)
- Blow air supply hose out prior to initial use.
- Visually inspect air hoses and fittings for frays, visible damage and signs of deterioration. Replace damaged or worn components.
- Refer to Dynabrade's Warning/Safety Operating Instructions Tag (Reorder No. **95903**) for safety information.

After maintenance is performed on tool, add a few drops of Dynabrade Air Lube (P/N **95842**) to the air line and start the tool a few times to lubricate air motor. Check for excessive tool vibration.

Handling and Storage:

- Use of tool rests, hangers and/or balancers is recommended.
- Protect tool inlet from debris (see Notice below).
- **DO NOT** carry tool by air hose.
- Protect abrasive accessories from exposure to water, solvents, high humidity, freezing temperature and extreme temperature changes.
- Store accessories in protective racks or compartments to prevent damage.

Machine Specifications

Model Number	Motor HP (W)	Motor RPM	Sound Level	Abrasive Belt Size Inch (mm)	Maximum Air Flow CFM/SCFM (LPM)	Max. SFPM (SMPM)	Weight Pound (kg)	Length Inch (mm)	Height Inch (mm)
All Models	.5 (373)	20,000	77 dB(A)	1/8-1/2 (3-13) W x 24 (610) L	4/31 (878)	5,800 (1,762)	3.1 (1.4)	14.6 (371)	4.6 (116)

Additional Specifications: Air Inlet Thread 1/4" NPT • Hose I.D. Size 3/8" or 10mm • Air Pressure 90 PSIG (6.2 Bars)

Notice

All Dynabrade motors use the highest quality parts and metals available and are machined to exacting tolerances. The failure of quality pneumatic motors can most often be traced to an unclean air supply or the lack of lubrication. Air pressure easily forces dirt or water contained in the air supply into motor bearings causing early failure. It often scores the cylinder walls and the rotor blades resulting in limited efficiency and power. Our warranty obligation is contingent upon proper use of our tools and cannot apply to equipment which has been subjected to misuse such as unclean air, wet air or a lack of lubrication during the use of this tool.

Index Key

No. Part # Description

1	Contact Arm Assembly	(See pages 8-11)
2	95218	Knob Assembly
3*	11420	Idler Arm Assy., Includes: 95070 Threaded Insert 11040 Spring
4	11359	Tension Spring
5*	95162	Screw (2)
6*	11011	Idler Wheel Assy. (2) Includes: 95162 Screw 11013 Bearing 11006 Idler Wheel
7	95216	Pivot Pin
8	11418	Housing
9	95311	Screw
10	40029	Motor Lock
11	11419	Cover
12	11424	Wave Spring
13	01197	Air Motor
14	01111	Drive Wheel
15	10295	Screen
16	04087	Lock Ring
17	04078	Felt Silencer
18	04084	Air Control Ring
19	04081	Rotor Nut
20	01007	Bearing
21	01121	Shim Pack (3/pkg.)
22	01008	Bearing Plate
23	50767	Pin (2)
24	01010	Rotor Spacer
25	01013	Cylinder
26	01011	Blade (4) (4/pkg.)
27	01120	Rotor
28	01244	Bearing Plate
29	01015	Bearing
30	95558	Retaining Ring
31	30420	Housing
32	01477	Valve Stem
33	95730	O-Ring
34	01024	O-Ring
35	01247	Speed Regulator Assembly
36	01953	Safety-Lock Throttle Lever
37	01017	Pin
38	01464	Seal
39	01472	Tip Valve
40	01438	Spring
41	53190	Block Plate
42	96065	O-Ring
43	01494	Inlet Adapter

Dynafile®

Complete Assembly Breakdown

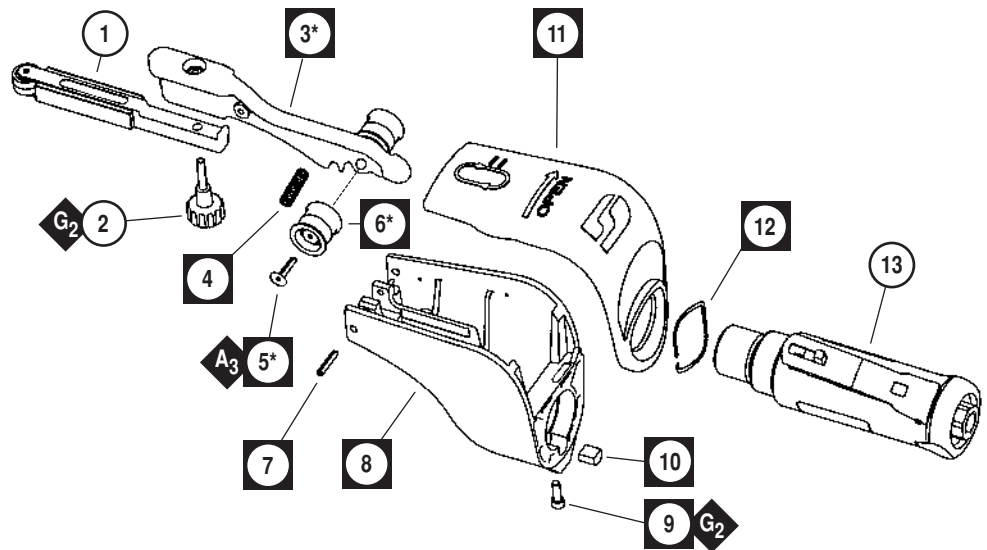

*Asterisk indicates parts that are included in 11421 Idler Arm Assembly.

Note: All Boxed index numbers represent 11431 Housing Assembly.

01197 Air Motor with 01111 Drive Wheel

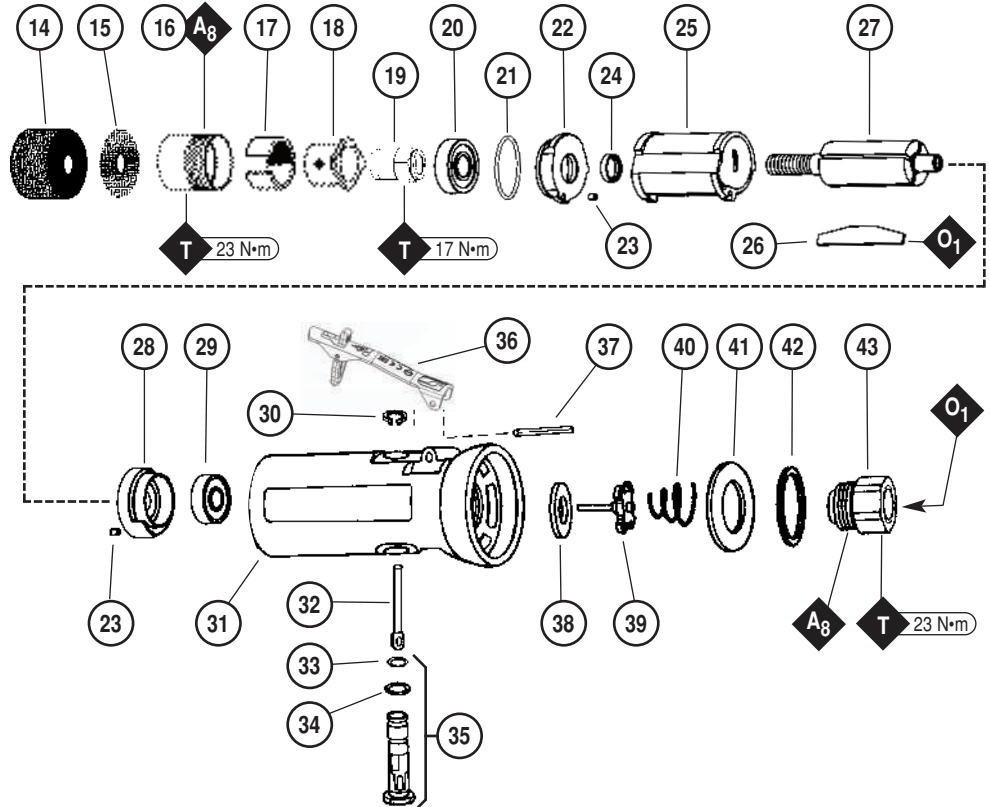

KEY	
O	Oil: O ₁ = Air Lube
A	Adhesive: A ₃ = Loctite #242 A ₈ = Loctite #567
T	Torque: N·m x 8.85 = In. - lbs.
G	Grease: G ₂ = Loctite #771

Note: 50971 Lock Ring Wrench is available for removal/installation of 04087 Lock Ring. See inside for Important Operating, Maintenance and Safety Instructions before operating tool.

Disassembly/Assembly Instructions – Dynafile®

Important: The manufacture warranty is void if the tool is disassembled before the warranty expires, by anyone other than a Dynabrade approved repair technician. **Notice:** A complete Motor Tune-Up Kit, part number 95600 is available. Also, the special repair tooling referred to in these instructions can be ordered through your Dynabrade Distributor. Please refer to this tool manual for correct part number identification.

Motor Disassembly:

1. Shut off the air supply, and depress throttle lever to dissipate the remaining air. Carefully disconnect the tool from the air supply hose.
2. Remove the abrasive belt and contact arm assembly.
3. Carefully hold the **11418** Housing in a vise with aluminum or bronze jaws.
4. Use a 9/64" hex key to loosen the **95311** Screw. Remove the **01197** Air Motor along with the **11424** Wave Spring and the **11419** Cover.
5. Hold the **01243** Housing of the **01197** Air Motor in a vise with aluminum or bronze jaws so that the drive wheel is pointing up. Fasten the flats near the inlet area of the housing.
6. Insert a 3/16" hex key through the **01111** Drive Wheel and into the end of the **01120** Rotor to hold it stationary. Grasp the drive wheel and turn it counterclockwise to remove. Remove the **10295** Screen.
7. Use the **50971** Lock Ring Wrench to remove the **04087** Lock Ring, turning it counterclockwise. Remove the **04084** Air Control Ring and the **04078** Felt Silencer. Pull the motor out of the housing.
8. Fasten the **96346** 2" Bearing Separator around the portion of the **01013** Cylinder closest to the **01244** Bearing Plate. Place the separator and the motor on the table of the **96232** #2 Arbor Press so that the threaded end of the rotor is pointing down.
9. Use a 3/16" or 5mm diameter flat end drive punch as a press tool and push the rotor out of the **01015** Bearing.
10. Remove the **01011** Blades (4).
11. The **01015** Bearing can be removed from the **01244** Bearing Plate with the **96211** Bearing Removal Tool and the arbor press.
12. Hold the blade portion of the **01120** Rotor in a vise with aluminum or bronze jaws and remove the **04081** Rotor Nut with an adjustable wrench, turning it counterclockwise.
13. The **01007** Bearing, **01008** Bearing Plate, **01121** Shims, and **01010** Spacer can now be removed from the **01120** Rotor.

Motor Disassembly Complete.

Valve Disassembly:

1. Hold the **01243** Housing in a vise with aluminum or bronze jaws. Fasten the flats near the inlet area of the housing so that the air inlet is pointing up.
2. Hold the **01494** Inlet Adapter stationary with a wrench and remove the air fitting with another wrench.
Important: The **01494** Inlet Adapter must be held stationary to prevent damage to the **01243** Housing.
3. Remove **01494** Inlet Adapter to access the **01438** Spring, **01472** Tip Valve, and **01464** Seal.
4. Use a 2.5mm drive punch to remove the **01017** Pin and the throttle lever.
5. The **01477** Valve Stem can be pulled out of the **01247** Speed Regulator Assembly.
6. Use retaining ring pliers to remove the **95558** Retaining Ring and then push the **01247** Speed Regulator Assembly out of the **01243** Housing.

Valve Body Disassembly Complete.

Idler Arm Disassembly:

1. Use a 1/8" or 3mm diameter drive punch to remove the **95216** Pivot Pin along with the **11420** Idler Arm Assembly and **11359** Tension Spring.
2. Use a 3/32" hex key to remove the **11011** Idler Wheel Assembly (2).

Idler Arm Disassembly Complete.

Important: Clean and inspect all parts before assembling.

Valve Assembly:

1. Hold the **01243** Housing in a vise with aluminum or bronze jaws. Fasten the flats of the housing near the inlet area so that the air inlet is pointing up.
2. Install the **01247** Speed Regulator Assembly (o-rings included) into the **01243** Housing and hold it in place with the **95558** Retaining Ring.
3. Insert the **01477** Valve Stem so that the end with the hole fits into the **01247** Speed Regulator Assembly.
4. Install the **01464** Seal into the air inlet so that it is laying flat.
5. Use a needle nose pliers to grasp the white nylon portion of the **01472** Tip Valve and insert the metal pin of the tip valve into the hole in the **01477** Valve Stem.
6. Install the **01438** Spring so that the smaller end of the spring fits against the center of the tip valve.
7. Install the **96065** O-Ring onto the **53190** Block Plate and install the block plate along with the o-ring so that the flat side of the block plate is positioned against the **01243** Housing.
8. Apply a small amount of the #567 Loctite® (or equivalent) to the threads of the **01494** Inlet Adapter and install the adapter into the housing. Torque to 23 N•m/200 lbs. in.
9. Install the throttle lever and fasten it with the **12132** Pin.

Valve Assembly Complete.

Idler Arm Assembly:

1. Apply a small amount of the Loctite® #242 (or equivalent) to the **95162** Screw (2) and install the **11011** Idler Wheel Assembly (2).
2. Install the **11359** Tension Spring into the **11418** Housing. Install the **11420** Idler Arm Assembly and fasten it into housing with the **95216** Pivot Pin.

Idler Arm Assembly Complete.

Motor Assembly:

1. Install the **01010** Spacer onto the rotor.
2. Select .003" (0.80mm) thickness in shims from the **01121** Shim Pack and place these into the **01008** Bearing Plate.
3. Install the **01007** Bearing into the bearing plate.

Disassembly/Assembly Instructions – Dynafile®

- Slip the bearing and plate onto the rotor.
- Install the **04081** Rotor Nut and check the clearance between the rotor and plate with a .001" (0.03mm) feeler gauge. The clearance should be .001"-.0015" (0.03-0.04mm). If the rotor/plate clearance needs adjustment, repeat steps 2-5 and remove or add shims as required to establish the correct clearance.
- Apply the **95842** Dynabrade® Air Lube, 10W/NR (or equivalent) to the 01011 Blades (4) and install these into the rotor.
- Install the **01013** Cylinder over the rotor so that the air inlet opening of the cylinder will align with the air inlet opening of the **01244** Bearing Plate.
- Use the **96241** Bearing Press Tool (position the raised outside diameter against the outside diameter of the bearing) and **96232** Arbor Press to install the **01015** Bearing into the bearing plate.
- Use the **96241** Bearing Press Tool (position the raised inside diameter against the inside diameter of the bearing) and the **96232** Arbor Press to install the bearing and plate onto the rear bearing journal of the rotor.
Important: Press the bearing and plate down onto the rotor until the **01244** Bearing Plate just touches the **01013** Cylinder. This fit will establish a preload on the motor bearings producing a "snug fit" between the bearing plates and the cylinder. If the fit is too tight it will cause the bearings to wear prematurely, too loose and the desired preload will not be achieved. If an adjustment is required, remove the bearing and plate. Repeat steps 7-9.
- Orient the motor assembly so that the air inlet passage in the housing aligns with the air passage in the **01244** Bearing Plate and install the motor assembly.
- Wrap the **04078** Felt Silencer around the **04084** Air Control Ring and install these into the **04087** Lock Ring.
- Apply a small amount of the Loctite® #567 (or equivalent) on the threads of the **04087** Lock Ring. Install the lock ring along with the air control ring and felt silencer onto the **01243** Housing. Torque to 23 N-m/200 lbs. in.
- Install the **11424** Wave Spring and the **11419** Cover onto the **01197** Air Motor.
- Insert the **01197** Air Motor into the **11418** Housing. Use a 9/64" hex key to fasten the motor in place with the **40029** Cam Lock and the **95311** Screw.
- Install a contact arm assembly and an abrasive belt onto the idler arm assembly.
- Adjust and Track the abrasive belt by hand. Close the **11419** Cover.
- Connect the Dynafile to the air supply hose. Open the air supply valve to charge the hose with air.
- Run the tool and check for proper operation.

Motor Assembly Complete. Tool Assembly Complete. Please allow 30 minutes for adhesives to cure before operating tool.

Important: Motor should now be tested for proper operation at 90 PSIG. If motor does not operate properly or operates at a higher RPM than marked on the tool, the tool should be serviced to correct the cause before use. Before operating, place 2-3 drops of Dynabrade Air Lube (P/N **95842**) directly into air inlet with throttle lever depressed. Operate tool for 30 seconds to determine if tool is operating properly and to allow lubricating oils to properly penetrate motor. Loctite® is a registered trademark of Loctite Corp.

Abrasive Belt Change and Removal:

To Remove Belt:

- Open **11419** Cover.
- Depress idler arm lever and pull belt away from the contact wheel.
- Slip belt off drive wheel.

To Replace Belt:

- Create a loop with belt by pinching together the sides of belt in the middle.
- Slip one loop under the **01111** Drive Wheel and around the idler arm.
- Depress idler arm lever and pull belt toward the contact wheel.
- Slip belt over contact wheel.
- Connect tool to power source.
- Adjust belt tracking using **95218** Knob.

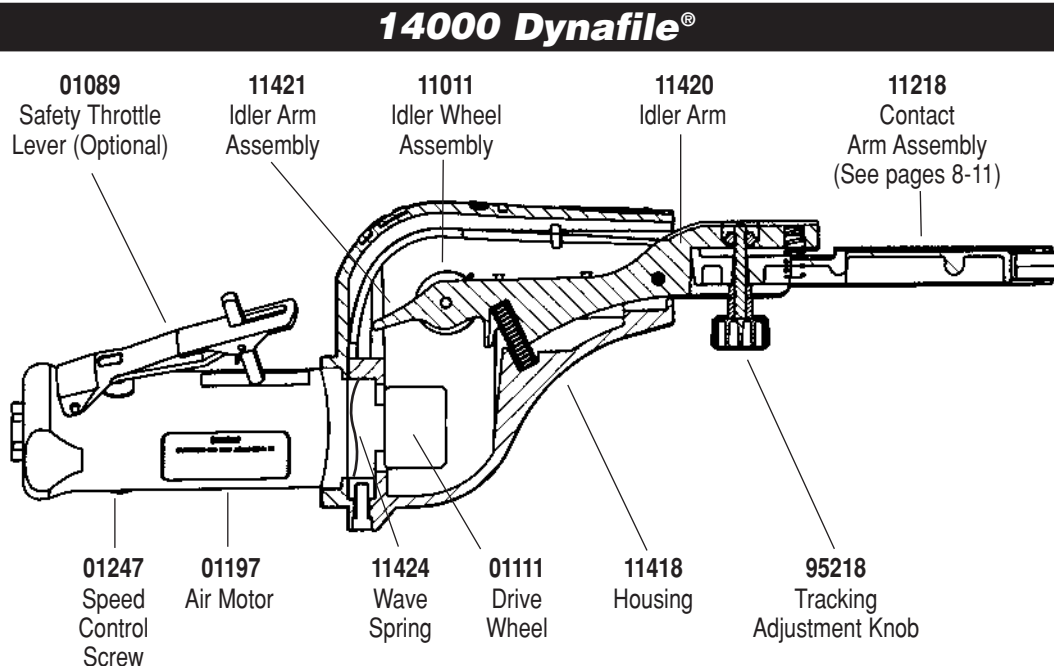

Preventative Maintenance Schedule

For All Dynafire® Models

This service chart is published as a guide to expectant life of component parts. The replacement levels are based on average tool usage over one year. Dynabrade Inc. considers one year usage to be 1,000 hours.

Parts Common to all Models:

Index #	Part Number	Description	Number Required	High Wear 100%	Medium Wear 70%	Low Wear 30%	Non-Wear 10%
1	See Note	Contact Arm Assembly	1				
2	95218	Knob Assembly	1			X	
3	11420	Idler Arm (Incl. 95070 Threaded Insert)	1				X
4	11359	Tension Spring	1			X	
5	95162	Screw	2				X
6	11011	Idler Wheel Assembly (Incl. 95162 Screw, 11013 Bearing & 11006 Idler Wheel)	2			X	
7	95216	Pivot Pin	1			X	
8	11418	Housing	1				X
9	95311	Screw	1			X	
10	40029	Motor Lock	1			L	
11	11419	Cover	1				X
12	11424	Wave Spring	1				X
13	01197	Air Motor	1				X
14	01111	Drive Wheel	1			X	
15	10295	Screen	1		T		
16	04087	Lock Ring	1				X
17	04078	Felt Silencer	2		T		
18	04084	Air Control Ring	1				X
19	04081	Rotor Nut	1				X
20	01007	Bearing	1		T		
21	01121	Shim Pack (3/pkg.)	1	T			
22	01008	Bearing Plate	1			X	
23	50767	Pin	1				X
24	01010	Rotor Spacer	1		T		
25	01013	Cylinder	1			X	
26	01011	Blade (4/pkg.)	1	T			
27	01120	Rotor	2				X
28	01244	Bearing Plate	1				X
29	01015	Bearing	1		T		
30	95558	Retaining Ring	1	T			
31	30420	Housing	1				X
32	01477	Valve Stem	2		T		
33	95730	O-Ring	1				X
34	01024	O-Ring	1				X
35	01247	Speed Regulator Assembly	1		T		
36	01953	Safety-Lock Throttle Lever	1			X	
37	01017	Pin	1		T		
38	01464	Seal	1		T		
39	01472	Tip Valve	1		T		
40	01438	Spring	1		T		
41	53190	Block Plate	1				X
42	96065	O-Ring	1		T		
43	01494	Inlet Adapter	1				X

LEGEND	
T	Included in Tune-Up Kit
X	Type of wear, no other comments apply.
L	Easily lost. Care during assembly/disassembly.
D	Easily damaged during assembly/disassembly.
R	Replace each time tool is disassembled.



95600 – Motor Tune-Up Kit

Note: Please refer to pages 8-10 of tool manual for specific part number.

Dynafile® Standard Contact Arm Assemblies

Part Number	Abrasive Belt Size	Contact Wheel Description	Comments	Contact Wheel Assembly	Contact Wheel Only	Bearing (2) Req.	Shaft
11178	1/2" x 34"	5/16" Dia. x 3/8" W Steel	9" Reach	11068	11067	11051	11054
11179	1/2" x 34"	5/8" Dia. x 3/8" W Rubber	9" Reach	11078	11077	11052	11054
11212	1/4" x 24"	5/16" Dia. x 1/8" W Steel	1/4" W Platen	11066	11065	11051 (1)	11056
11213	1/2" x 24"	5/16" Dia. x 3/8" W Steel	1/2" W Platen	11068	11067	11051	11054
11214	1/2" x 24"	7/16" Dia. x 3/8" W Rubber	1/2" W Platen	11070	11069	11051	11054
11215	1/4" x 24"	7/16" Dia. x 1/8" W Brass	1/4" W Platen	11072	11071	11052 (1)	11053
11216	1/4" x 24"	5/8" Dia. x 1/8" W Rubber	1/4" W Platen	11074	11073	11052 (1)	11053
11217	1/2" x 24"	1/2" Dia. x 3/8" W Steel	1/2" W Platen	11076	11075	11052	11054
11218	1/2" x 24"	5/8" Dia. x 3/8" W Rubber	1/2" W Platen	11078	11077	11052	11054
11219	1/4" or 1/2" x 24"	1" Dia. x 3/8" W Radiused Rubber	No Platen	11080	11079	11052	11054
11228	1/2" x 24"	5/8" Dia. x 3/8" W Rubber	H.D. Version of 11218 Arm	11078	11077	11052	11054
11231	1/2" x 24"	3/4" Dia. x 1/2" W Rubber	1/2" W Platen	11084	11083	11052	11055
11232	1/8" or 1/4" x 24"	1" Dia. x 3/8" W Tapered Urethane	No Platen	11086	11085	11052	11054
11234	1/2" x 34"	1" Dia. x 3/8" W Radiused Rubber	Double Burrer Arm	11080 (2)	11079 (2)	11052	N/A
11237	5/16" x 24"	5/16" Dia. x 1/8" W Steel	Polish Turbine Blades	11066	11065	11051 (1)	11053
11238	1/2" x 24"	1/4" Dia. x 3/8" W Steel	Polish Turbine Blades	11051 (3) and 11054	11051 (3)	N/A	11054
11239	1/2" x 24"	5/16" Dia. x 3/8" W Steel	H.D. Version of 11213 Arm	11068	11067	11051	11054
11240	1/2" x 34"	5/8" Dia. x 3/8" W Rubber	1/2" W Platen - 9" Reach	11078	11077	11052	11054
11241	1/4" x 34"	5/8" Dia. x 1/8" W Rubber	1/4" W Platen - 9" Reach	11074	11073	11052 (1)	11053
11243	1/2" x 24"	3/4" Dia x 1/2" W Rubber	H.D. Version of 11231 Arm	11084	11083	11052	11055
11244	1/2" x 44"	5/8" Dia. x 3/8" W Rubber	1/2" W Platen - 14" Reach	11078	11077	11052	11054
11245	1/4" x 44"	5/8" Dia. x 1/8" W Rubber	1/4" W Platen - 14" Reach	11074	11073	11052 (1)	11053
11254	1/2" or 1/4" x 34"	4-3/4" or 2-1/8" Dia. to 1/4" or 1/2" W	Grind in Deep Narrow Slots	Variable	Variable	11013 (1)	95162
11255	1/2" x 34"	5/8" Dia. x 3/8" W Rubber	Deburr I.D. 1" to 4"	11078	11077	11052	11054
11257	1/2" Wide	5/16" Dia. x 3/8" W Steel or 5/8" Dia. x 3/8" W Rubber	"Spear-Arm" - Specify length up to 32"	11068 Steel 11078 Rubber	11067 Steel 11077 Rubber	11051 Steel 11052 Rubber	11054
11258	1/2" x 24"	1/2" Dia. x 3/8" W Steel and 5/8" Dia. x 3/8" W Rubber	Platen Between 2 Contact Wheels	11076 Steel 11078 Rubber	11075 Steel 11077 Rubber	11052 (4)	11054 (2)
11261	1/2" x 24"	5/8" Dia. x 3/8" W Rubber	"Banana Arm" - For in-line scratch pattern.	11078	11077	11052	11054
11262	1/2" x 24"	5/8" Dia. x 3/8" W Rubber	"Offset Arm" - Contact wheel is offset to prevent gouging.	11078	11077	11052	11054
11297	1/2" x 24"	5/8" Dia. x 3/8" W Rubber	Contains two 11395 Guide Wheels. Prevents undercutting.	11090	11077	11052	95610

See next page for a complete guide to contact arms. Also see page 11 for contact arm disassembly and assembly instructions.



11288 Dynafile Contact Arm and Idler Wheel Repair Kit

- Contains special tools to assist in the replacement of contact wheels and bearings.

Dynafile® Standard Contact Arms

Standard Contact Arms allow for a 4" workable reach.

11212

File round openings as small as 7/16".
45 PSIG maximum.



Belt Size: 1/4" W x 24" L.

11066 Contact Wheel: 5/16" diameter x 1/8" wide, steel.

11034 Platen: 1/4" wide.

11213

See 11239 for heavy-duty version.
45 PSIG maximum.



Belt Size: 1/2" W x 24" L.

11068 Contact Wheel: 5/16" diameter x 3/8" wide, steel.

11027 Platen: 1/2" wide.

11214

Work on contact wheel or Dynapad®.
45 PSIG maximum.



Belt Size: 1/2" W x 24" L.

11070 Contact Wheel: 7/16" diameter x 3/8" wide, rubber.

11025 Platen: 1/2" wide.

11215

Enter 1/2" x 1/2" openings.



Belt Size: 1/4" W x 24" L.

11072 Contact Wheel: 7/16" diameter x 1/8" wide, brass.

11034 Platen: 1/4" wide.

11216

Enter 5/16" x 3/4" openings.



Belt Size: 1/4" W x 24" L.

11074 Contact Wheel: 5/8" diameter x 1/8" wide, rubber.

11032 Platen: 1/4" wide.

11217

Enter channels as narrow as 9/16".



Belt Size: 1/2" W x 24" L.

11076 Contact Wheel: 7/16" diameter x 3/8" wide, steel.

11027 Platen: 1/2" wide.

11218

Standard arm on model 14000.
See 11228 for heavy-duty version.



Belt Size: 1/2" W x 24" L.

11078 Contact Wheel: 5/8" diameter x 3/8" wide, rubber.

11025 Platen: 1/2" wide.

11219

No platen due to offset design.
Grind radiuses, slack polish.



Belt Size: 1/4" or 1/2" W x 24" L.

11080 Contact Wheel: 1" diameter x 3/8" wide, radiused rubber.

No Platen

11228 Heavy-Duty Steel

Optional **11028** Steel Platen
available for grinding.



Belt Size: 1/2" W x 24" L.

11078 Contact Wheel: 5/8" diameter x 3/8" wide, rubber.

11025 Platen: 1/2" wide.

11231

See 11243 for heavy-duty version.



Belt Size: 1/2" W x 24" L.

11084 Contact Wheel: 3/4" diameter x 1/2" wide, rubber.

11135 Platen: 1/2" wide.

11232 For 1/8" Wide Belts

V-Tapered

No platen due to offset design.
Grind corners, strap polish.



Belt Size: 1/8" or 1/4" W x 24" L.

11086 Contact Wheel: 1" diameter x 3/8" wide, tapered urethane.

No Platen.

11239 Heavy-Duty Steel

Grind in narrow areas.
45 PSIG maximum.



Belt Size: 1/2" W x 24" L.

11068 Contact Wheel: 5/16" diameter x 3/8" wide, steel.

11027 Platen: 1/2" wide.

11243 Heavy-Duty

Grind over contact wheel or Dynapad®.



Belt Size: 1/2" W x 24" L.

11084 Contact Wheel: 3/4" diameter x 1/2" wide, rubber.

11135 Platen: 1/2" wide.

11262 "Offset Arm"

For flat grinding using platen at or near corners
and edges of large radius round. Contact wheel
is offset to prevent gouging.

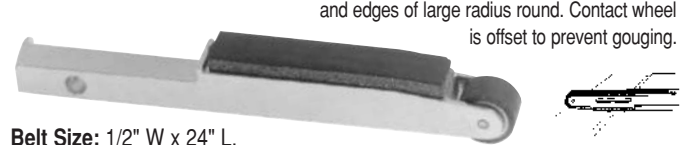

Belt Size: 1/2" W x 24" L.

11078 Contact Wheel: 5/8" diameter x 3/8" wide, rubber.

11026 Platen: 1/2" wide.

Dynaflex® Specialized Contact Arms

Designed to solve tough production problems.

11237 and 11238 Turbine Blade Arms

45 PSIG maximum.



11237: 1/4" wide x 24" long belts.
 11066 Contact Wheel: 5/16" dia. x 1/8" wide steel wheel.
 11238: 1/2" wide x 24" long belts.
 Contact Wheel: 1/4" dia. x 3/8" wide steel wheel.

11255 Cross-Bow Arm

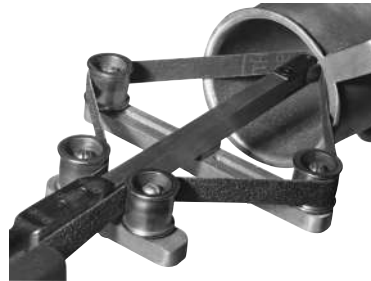

- I.D. polishing or deburring with one 180° wrist turn.
- Deburr leading radius of 1" to 4" round openings.

Belt Size: 1/2" W x 34" L.

11234 Double-Burrer Arm



- Deburrs both edges of workpiece simultaneously.
- Contact wheels adjust for material 1/8" to 5/8" thick.

Belt Size: 1/2" wide x 34" long.
 11080 Contact Wheels: 1" diameter x 3/8" wide, rubber.

11257, 11178 and 11179 Spear Arms



11257: Custom-made. Specify usable length up to 32".
 Specify 11068 - 5/16" diameter steel or 11078 - 5/8" diameter rubber contact wheel.

11178: Has 9" reach with 11068 - 5/16" diameter steel contact wheel.
 Belt Size: 1/2" W x 34" L (45 PSIG Max.).

11179: Has 9" reach with 11078 - 5/8" diameter rubber contact wheel.
 Belt Size: 1/2" W x 34" L.

11240, 11241, 11244 and 11245 Extra-Length Arms



9" Workable Reach:

11240 Arm:
 Belt Size: 1/2" W x 34" L belts.
 11078 Contact Wheel:
 5/8" dia. x 3/8" wide, rubber.

11241 Arm:
 Belt Size: 1/4" W x 34" L belts.
 11074 Contact Wheel:
 5/8" dia. x 1/8" wide, rubber.

14" Workable Reach:

11244 Arm:
 Belt Size: 1/2" W x 44" L belts.
 11078 Contact Wheel:
 5/8" dia. x 3/8" wide, rubber.

11245 Arm:
 Belt Size: 1/4" W x 44" L belts.
 11074 Contact Wheel:
 5/8" dia. x 1/8" wide, rubber.

11258 Stroke Sander Arm

Blend stainless steel.

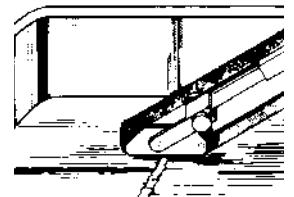

Belt Size: 1/2" W x 24" L.
 11078 Contact Wheel: 5/8" diameter x 3/8" wide, rubber.
 Platen: 1/2" W x 7/8" L.

11254 Big Wheel Arm

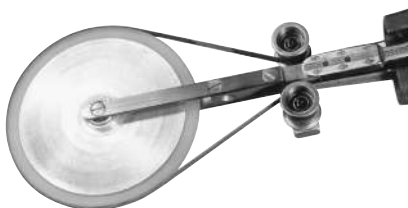

- Grinds and polishes deep slots or narrow groves.
- 1/4" to 1/2" wide wheels, 2-1/8" to 4-3/4" diameter (specify size).

Belt Size: 1/4" to 1/2" W x 34" L.

11253 Arms (specify width)

11377 Contact Wheel: 2-1/8" dia. x 1/2" wide, urethane.
 11378 Contact Wheel: 2-1/8" dia. x 1/4" wide, urethane.

11254 Arms (specify width)

11375 Contact Wheel: 4-3/4" dia. x 1/2" wide, urethane.
 11375 Contact Wheel: 4-3/4" dia. x 1/4" wide, urethane.

11297 Guide-Cut Arm



- Guide wheels prevent undercutting.
- Removes raised material within .020" or less.
- Use 60 to 80 grit abrasive belts with this arm.

Belt Size: 1/2" W x 24" L, 60 to 80 grit.
 11090 Contact Wheel: 5/8" diameter x 3/8" wide rubber.

MAINTENANCE INSTRUCTIONS

Important: To keep tool safe, a Preventative Maintenance Program is recommended. The program should include inspection of the tool and all related accessories and consumables, including air lines, pressure regulators, filters, oilers, etc. (refer to CAGI B186.1 for additional maintenance information). If accessory or tool breakage occurs, investigate failure to determine the cause and correct before issuing tool for work. Use the following schedule as a starting point in developing a Preventative Maintenance Program. If tool does not operate properly (RPM, vibration, start/stop) after these scheduled checks or at any time, the tool must be repaired and corrected before returning tool to use.

INSTALLATION



- To ensure long life and dependable service, use a Closed Loop Air System and Filter-Regulator-Lubricator (FRL) as diagramed below.
- Each tool should have its own dedicated hose connected to an air supply FRL. Quick disconnects should be installed at the FRL in an effort to reduce contamination into the tool. Securely affix all fittings and hose assemblies.
- It is strongly recommended that all Dynabrade rotary vane air tools be used with a Filter-Regulator-Lubricator to minimize the possibility of misuse due to unclean air, wet air or insufficient lubrication. Dynabrade recommends the following: **10690** Air Line Filter-Regulator-Lubricator — Provides accurate air pressure regulation, two-stage filtration of water contaminants and micro-mist lubrication of pneumatic components.
- Dynabrade recommends 1 drop of air lube per minute for each 20 SCFM (example: if the tool specification states 40 SCFM, set the drip rate on the filter-lubricator to 2 drops per minute). **95842** Dynabrade Air Lube is recommended.

MAINTENANCE SCHEDULE

Maintenance schedules depend on the type and style of tool. Refer to page 3 to reference symbols associated with specific maintenance items/areas. Match maintenance schedules accordingly. See page 4 for any additional maintenance information.

Note: Turbine style air motors do not require oil.

Daily (every 8 hours):

- Inspect tool and accessories for damage or broken parts. Replace items as necessary to ensure proper operation and safety.
-  Lubricate motor as recommended. Use **95842** Dynabrade Air Lube (10W/NR). Apply 1 drop/minute of air lube per 20 SCFM.
- Check air line pressure with a gage. (MAX. 90 PSIG or 6.2 Bar operating pressure at the air inlet of the tool.)
-  Lubricate wick system and right angle gears through gear case fitting. Apply 3 plunges of **95848** Gear Oil. Use **95541** Lubricant Gun (Prime lubricant gun before use).
- Check tool for proper operation: If operating improperly or demonstrates unusual vibration, the tool must be serviced and problem corrected before further use.

Every 20 Hours/Once a Week (which ever comes first):

-  For tools without "wick system", lubricate right angle gears through lubricant fitting. Apply 1 plunge of **95544** Grease. Use **95541** Lubricant Gun. (Prime lubricant gun before use).
- Measure RPM (speed) by setting air pressure to 90 PSIG (6.2 Bar) at tool inlet, without accessory mounted, while the tool is running. Using

tachometer, check spindle speed of the tool. Unless otherwise stated the no-load speed may not exceed the rated speed. If tool speed exceeds maximum rated RPM, service as required and correct before use.

- If tool is running too fast: look for worn, damaged or missing governor, air control rings and silencer(s). Service as required.
- If tool is running too slow: look for malfunctioning governor, clogged inlet screen, silencer(s) or air stream. Service as required.

Note: Special care must be taken when servicing governors. Refer to specific tool manual for governor instructions and/or speed control devices. Governor assemblies made from molded plastic components are non-serviceable and must be replaced.

Every 50 Hours:

-  Lubricate planetary gears through gear case fitting with 3 plunges of **95544** Grease. Use **95541** Lubricant Gun. (Prime lubricant gun before use).

REPAIR

- Use only genuine Dynabrade replacement parts to ensure quality. To order replacement parts, specify Model#, Serial# and RPM of your air tool.
- Mineral spirits are recommended when cleaning the tool and parts. Do not clean tool or parts with any solvents or oils containing acids, esters, ketones, chlorinated hydrocarbons or nitro carbons.
- A Motor Tune-Up Kit is available which includes high wear and medium wear motor parts.
- Air tool markings must be kept legible at all times, if not, reorder housing and replace. User is responsible for maintaining specification information.

-  After maintenance is performed on tool, add a few drops of **95842** Dynabrade Air Lube to the tool inlet and start the tool a few times to lubricate air motor. Verify RPM (per 20 hr maintenance schedule), vibration and operation.

HANDLING & STORAGE

- Use of tool rests, hangers and/or balancers is recommended.
- Protect tool inlet from debris (see Notice below).
- Do Not** carry tool by air hose or near the tool throttle lever.
- Store accessories in protective racks or compartments to prevent damage.
- Follow the handling instructions outlined in the operating instructions when carrying the tool and when changing accessories.
- Protect accessories from exposure to water, solvents, high humidity, freezing temperature and extreme temperature changes.

END OF USE/DISPOSAL

When tool has reached its end of useful service, disassemble tool into its primary components (i.e. steel, aluminum and plastic) and recycle or discard per local, state and/or federal regulations as to not harm the environment.

NOTICE

All Dynabrade air motors use the highest quality parts available and are manufactured to exacting tolerances. Air motor failures are often traced to lack of lubrication or unclean air supply. Compressed air can force dirt and other contaminants into motor bearings causing early failure. Contaminants can score cylinder wall and vanes resulting in reduced efficiency and power. Our warranty obligation is contingent upon proper use of our tools. Air motors which have been subjected to misuse, contaminated air or lack of lubrication will void warranty.

CLOSED LOOP AIR SYSTEM

Sloped in Direction of Air Flow

- Dynabrade Air Power Tools are designed to operate at 90 PSIG (6.2 Bar) maximum air pressure at the tool inlet, when the tool is running. Use recommended regulator to control air pressure.
- Ideally the air supply should be free from moisture. To facilitate removing moisture from air supply, the installation of a refrigerated air dryer after the compressor and the use of drain valves at each tool station is recommended.

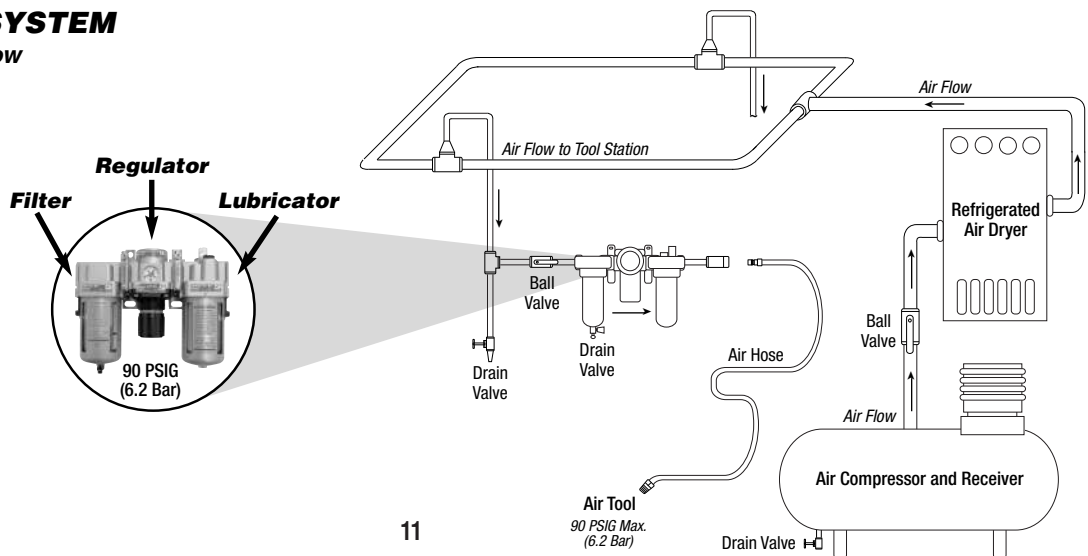

Lubricator Setting

1 Drop/Minute per 20 SCFM

Optional Accessories



Composite Dynaswivel®

Swivels 360° at two locations which allows an air hose to drop straight to the floor, no matter how the tool is held.

- 94300: 1/4" NPT.



50971 Lock Ring Tool

- Lock Ring Tool has a 3/8 in. square socket for use with 3/8 in. drive; breaker bar, ratchet head, or torque wrenches.



96211 Bearing Removal Tool

- This tool is designed to pass through the I.D. of the bearing plate and push against the I.D. of the bearing.



96241 Bearing Press Tool

- This tool is designed to safely press a bearing into a bearing plate and onto a shaft.



95600 Motor Tune-Up Kit:

- Includes assorted parts to help maintain and repair motor.



Dynabrade Air Lube

- Formulated for pneumatic equipment.
- Absorbs up to 10% of its weight in water.
- Prevents rust and formation of sludge.
- Keeps pneumatic tools operating longer with greater power and less down time.

95842: 1 pt. (473 ml)

95843: 1 gal. (3.8 L)



11288 Dynafire Contact Arm and Idler Wheel Repair Kit

- Contains special tools to assist in the replacement of contact wheels and bearings.

