

PORTABLE
FORCED AIR HEATERS
“USER’S MANUAL”



MODEL: DFA50

DFA80T

DFA135C

DFA180CV

DFA220CV



C

US



Before the first use of this heater, please read this USER’S MANUAL very carefully. This USER’S MANUAL has been designed to instruct you as to the proper manner in which to assemble, maintain, store, and most importantly, how to operate the heater in a safe and efficient manner. Please keep this manual for future reference.



CALIFORNIA RESIDENTS ONLY-WARNING: This product and the fuel used to operate this product (kerosene), and the products of combustion of such fuel, can expose you to chemicals including benzene, which is known to the State of California to cause cancer and reproductive harm. For more information go to: www.P65Warnings.ca.gov

**NEVER LEAVE THE HEATER
UNATTENDED WHILE BURNING!**

⚠ DANGER: IMPROPER USE OF THIS HEATER CAN RESULT IN SERIOUS INJURY OR DEATH FROM BURNS, FIRE, EXPLOSION, ELECTRICAL SHOCK AND/OR CARBON MONOXIDE POISONING.

⚠ WARNINGS:

1. RISK OF INDOOR AIR POLLUTION!

- Use **this heater only in well ventilated areas.** Provide at least a three-square foot (2,800 sq. cm.) opening of fresh outside air for each 100,000 BTU/hr. of heater rating.
- People with breathing problems should consult a physician before using the heater.
- **Carbon monoxide poisoning:** Early signs of carbon monoxide poisoning resemble the flu, with headaches, dizziness and/or nausea. If you have these signs, the heater may not be working properly.
Get fresh air at once! Have the heater serviced. Some people are more affected by carbon monoxide than others. These include pregnant women, persons with heart or lung disease or anemia, those under the influence of alcohol, or those at high altitudes.
- Never use this heater in living or sleeping areas.

2. RISK OF BURNS / FIRE / EXPLOSION!

- **NEVER** use any fuel other than 1-K kerosene, #1/#2 diesel/fuel oil, JET A or JP-8 fuels in this heater.
- **NEVER** use fuel such as gasoline, benzene, paint thinners or other oil compounds in this heater.
(RISK OF FIRE OR EXPLOSION)
- **NEVER** use this heater where flammable vapors may be present.
- **NEVER** refill the heaters fuel tank while heater is operating or is still hot.

⚠ CAUTION: Hot while in operation. Do not touch. Keep children, clothing and combustibles away from heater.

Minimum Clearances: Outlet: 8 feet (250cm) / Sides, top and rear: 4 feet (125cm)

- **NEVER** block air inlet (rear) or air outlet (front) of heater.
- **NEVER** use duct work in front or behind of heater.
- **NEVER** move or handle heater while it is hot, operating, or plugged in.
- **NEVER** transport heater with fuel in it's tank.
- When used with an optional thermostat or if equipped with a thermostat, heater may start at any time.
- **ALWAYS** locate heater on a stable and level surface.
- **ALWAYS** keep children and animals away from heater.
- Bulk fuel storage should be a minimum of 25 ft. from heaters, torches, portable generators or other sources of ignition.
All fuel storage should be in accordance with federal, state or local authorities having jurisdiction.

3. RISK OF ELECTRIC SHOCK!

- Use only the electrical power (voltage and frequency) specified on the model plate of the heater.
- Use only a three-prong, grounded outlet and extension cord.
- **ALWAYS** install the heater so that it is not directly exposed to water spray, rain, dripping water or wind.
- **ALWAYS** unplug the heater when not in use.

MASSACHUSETTS RESIDENTS: Massachusetts state law prohibits the use of this heater in any building which is used in whole or in part for human habitation. Use of this heating device in Massachusetts requires local fire dept. permit (M.E.L.C. 148, Section 10A.)

CANADIAN RESIDENTS: Use of this heater shall be in accordance with authorities having jurisdiction and CSA Standard B139.

NEW YORK CITY RESIDENTS: For use only at construction sites in accordance with applicable NYC codes under NYCFD certificate of approval # 5034 and 5037.

**NEVER LEAVE THE HEATER
UNATTENDED WHILE BURNING!**

CONTENTS OF USER'S MANUAL

<u>ITEM</u>	<u>PAGE #</u>
PRECAUTIONS - SAFETY GUIDE	1
1. INTRODUCTION	2
2. FEATURES	2
3. UNPACKING AND ASSEMBLY	4
4. FUELS	6
5. OVERVIEW OF HEATER DESIGN.....	7
6. FUELING YOUR HEATER	8
7. OPERATION	8
8. LONG TERM STORAGE OF YOUR HEATER	9
9. MAINTENANCE	10
10. REPLACING FUSE	14
11. TROUBLESHOOTING GUIDE	15
12. WIRING DIAGRAM.....	16
13. SPECIFICATIONS	17
14. EXPLODED PARTS DRAWING.....	18
15. PARTS LIST	21

1. INTRODUCTION

Please read this USER'S MANUAL carefully. It will show you how to assemble, maintain, and operate the heater safely and efficiently to obtain full benefits from its many built-in features.

2. FEATURES

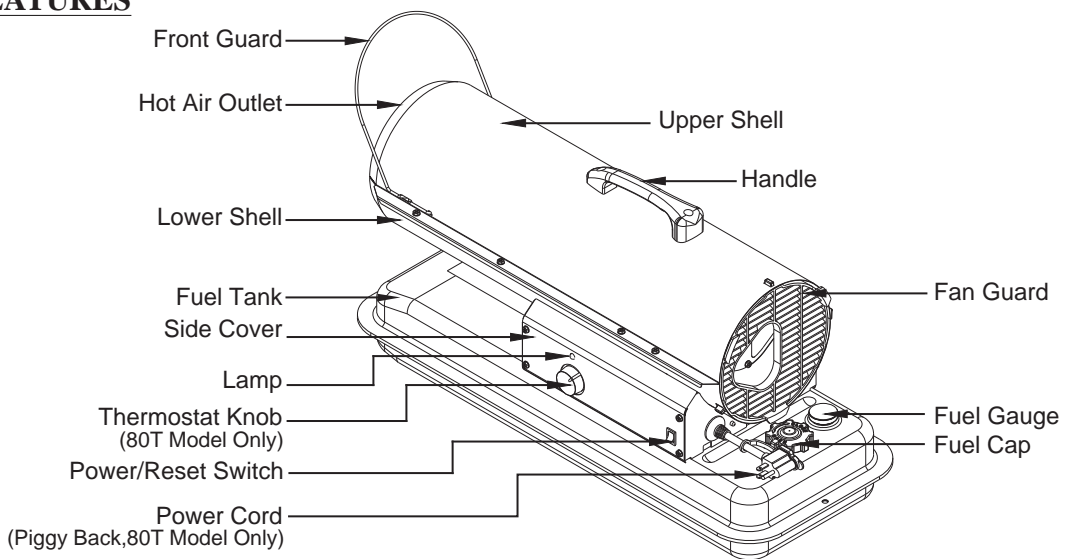

Figure 1. DFA50 / DFA80T MODELS

**NEVER LEAVE THE HEATER
UNATTENDED WHILE BURNING!**

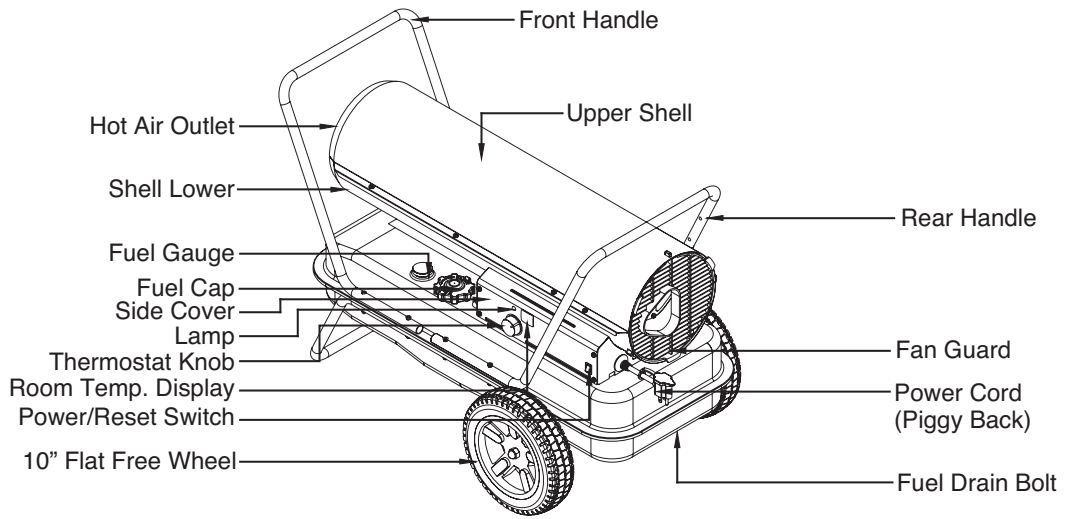

Figure 2. DFA135C MODEL

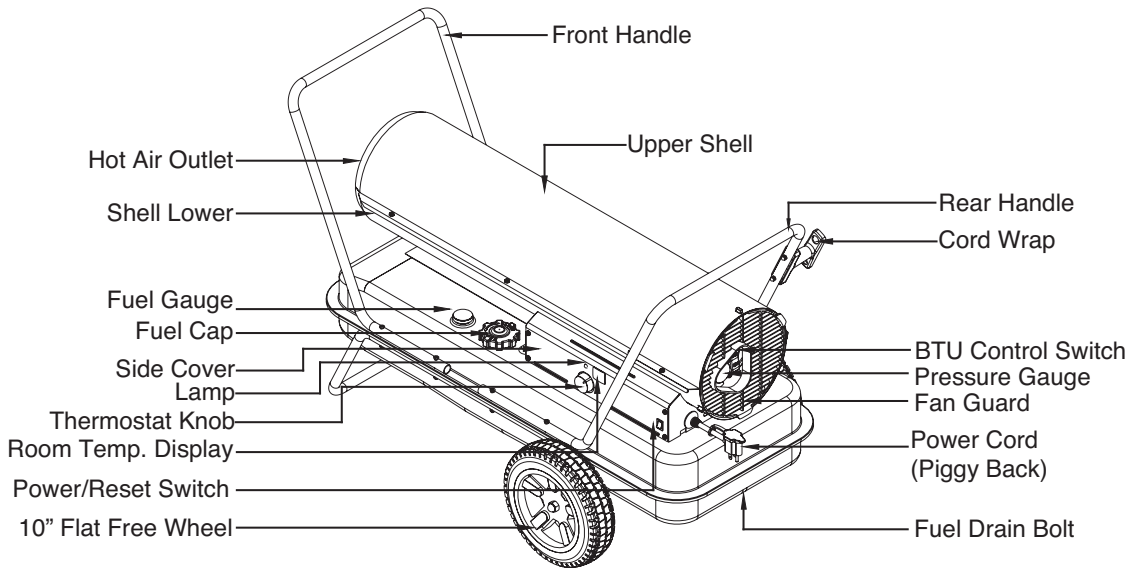

Figure 3. DFA180CV / DFA220CV MODELS

**NEVER LEAVE THE HEATER
UNATTENDED WHILE BURNING!**

3. UNPACKING AND ASSEMBLY

1. REMOVE THE HEATER AND ALL PACKING MATERIALS FROM THE BOX. (Fig. 4 and 5)

NOTE : Save the shipping carton and packing materials for future storage.

	DFA50/80T	DFA135C	DFA180CV	DFA220CV
Wheel Support Frame	No	Yes	Yes	Yes
Wheel	No	Yes	Yes	Yes
Threaded Axle	No	Yes	Yes	Yes
Front Handle	No	Yes	Yes	Yes
Rear Handle	No	Yes	Yes	Yes
Handle	Yes	No	No	No
Cord Wrap	No	No	Yes	Yes
Hardware kit : HW-KFA1016	No	Yes	Yes	Yes

Figure 4. DFA50 / 80T MODELS

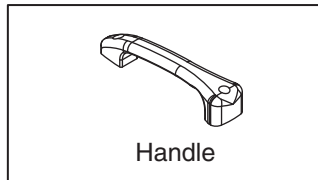
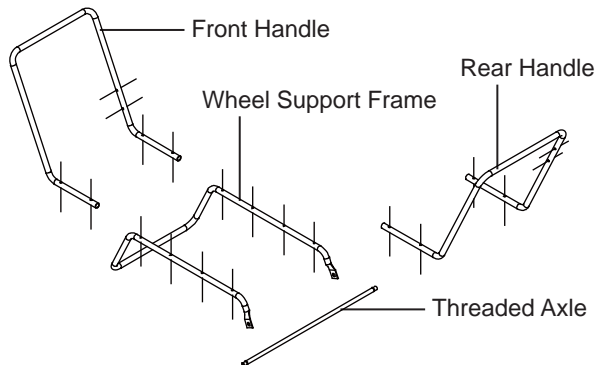
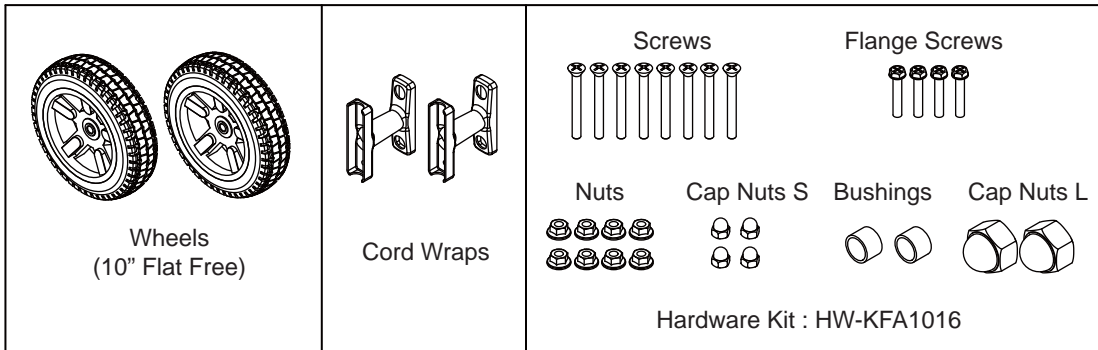

Figure 5. DFA135C / 180CV / 220CV MODELS



**NEVER LEAVE THE HEATER
UNATTENDED WHILE BURNING!**

2. ASSEMBLY

For DFA50/80T Models only

Tools Required

- Medium Phillips Screwdriver.
- 1) Lift front guard for arrow direction and make sure that guard's wedged portion fits into the slit hole on the upper housing.
 - 2) Remove the pre-assembled screws on the shell upper.
 - 3) Align the holes in the upper housing with two mounting holes on the handle as shown in Figure 6.
 - 4) Secure handle with the screws removed.

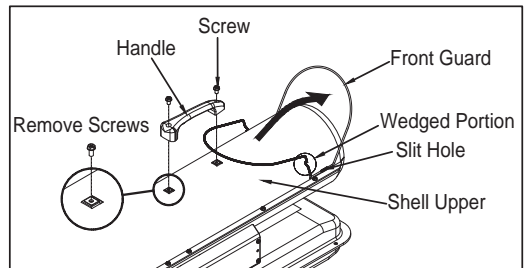

Figure 6. Assembling Handle

For DFA135C/180CV/220CV Models only

Tools Required

- Medium Phillips Screwdriver.
- 3/4 inch socket or adjustable wrench

Assembling Handle & Wheel and Cord Wrap

- 1) Slide threaded axle through the rear section of the wheel support frame.
- 2) Slide one axle bushing on to each side of the axle. Slide one wheel on to each side of the axle. Attach one cap nut on to each side of the threaded axle and tighten well.
- 3) Place heater on wheel support frame. Align the holes on fuel tank flange with holes on wheel support frame.
- 4) Position the Handles on top of fuel tank flange. Insert screws through handles, fuel tank flange and wheel support frames as shown in Figure 8 and attach nut finger tight after each screw is inserted.
- 5) Align the hole on the handles with the mounting hole on the Cord Wrap. Insert Screws through Cord Wrap, handles and attach nut finger tight after each screw is inserted. (DFA180CV/220CV Models only)
- 6) After all screws are inserted, tighten nuts firmly.

**NEVER LEAVE THE HEATER
UNATTENDED WHILE BURNING!**

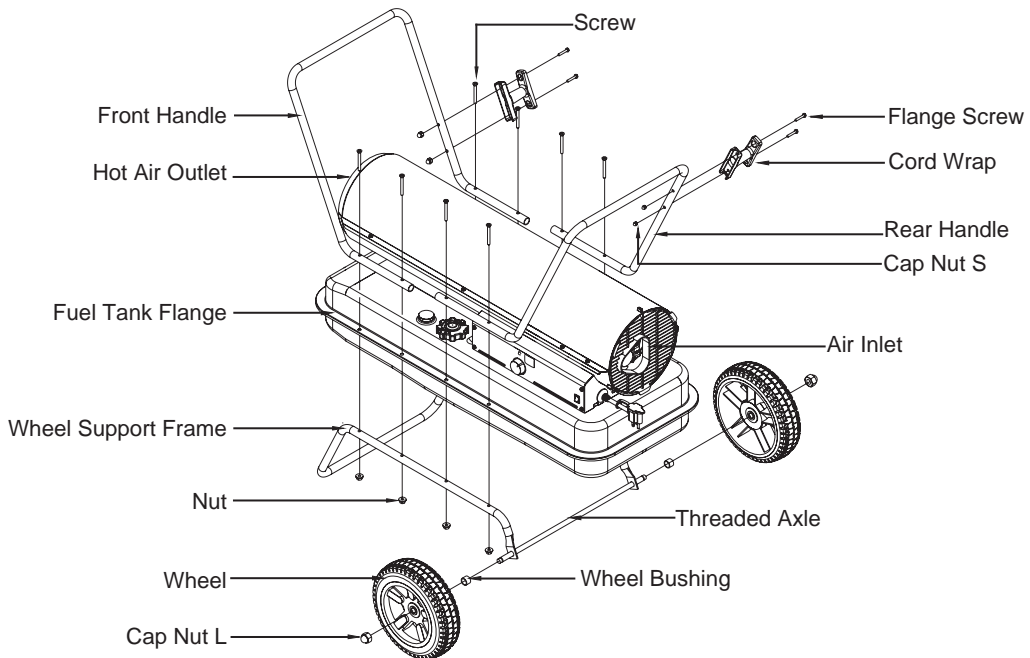

Figure 7. Assembling Handle, Wheel and Cord wrap

⚠ CAUTION: DO NOT OPERATE heater without support frame assembled to tank.

NOTE: Heater should be inspected before each use, and at least annually by a qualified service person.

4. FUELS

For optimal performance of this heater, it is strongly suggested that 1-K kerosene be used. 1-K kerosene has been refined to virtually eliminate contaminants, such as sulfur. Which can cause a rotten egg odor during the operation of the heater. However, #1/#2 diesel/fuel oil, JET A or JP-8 fuels may also be used if 1-K kerosene is not available. Be advised that these fuels do not burn as clean as 1-K kerosene, and care should be taken to provide more fresh air ventilation to accommodate any added contaminants that may be added to the heated space. #2 diesel/fuel oil heavier than 1-K kerosene in extreme cold temperatures without nontoxic anti-icer additives will not ignite properly.

KEROSENE SHOULD ONLY BE STORED IN A BLUE CONTAINER THAT IS CLEARLY MARKED “KEROSENE”. NEVER STORE KEROSENE IN A RED CONTAINER.

Red containers are associated with gasoline.

NEVER store kerosene in the living space. Kerosene should be stored in a well ventilated place outside the living area.

NEVER use any fuel other than 1-K kerosene (#1/#2 diesel/fuel oil, JET A or JP-8 fuels are acceptable substitutes)

NEVER use fuel such as gasoline, benzene, alcohol, white gas, camp stove fuel, paint thinners, or other oil compounds in this heater. These are volatile fuels that can cause an explosion or uncontrolled flames.

NEVER store kerosene in direct sunlight or near a source of heat.

NEVER use kerosene that has been stored from one season to the next. Kerosene deteriorates over time.

“OLD KEROSENE” WILL NOT BURN PROPERLY IN THIS HEATER.

**NEVER LEAVE THE HEATER
UNATTENDED WHILE BURNING!**

5. OVERVIEW OF HEATER’S DESIGN

Fuel System: This heater is equipped with an electric air pump that forces air through the air line connected to the fuel intake and then through a nozzle in the burner head. When the air passes in front of the fuel intake it causes fuel to rise from the tank and into the burner nozzle. This fuel and air mixture is then sprayed into the combustion chamber in a fine mist.

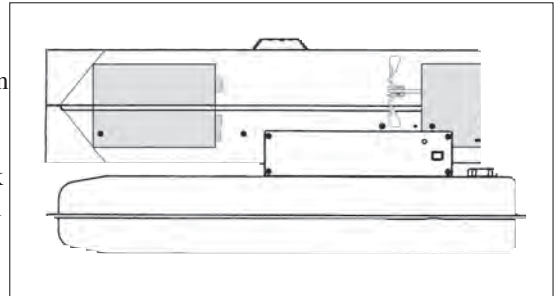

“Sure Fire Ignition” : The electronic ignitor sends voltage to a specially designed spark plug. The spark plug ignites the fuel and air mixture described above.

The Air System : The heavy duty motor turns a fan that forces air into and around the combustion chamber. Here the air is heated and then forced out the front of the heater.

The Safety System :

A. Temperature Limit Control : This heater is equipped with a Temperature Limit Control designed to turn off the heater should the internal temperature rise to an unsafe level. If this device activates and turns your heater off it may require service.

MODELS	Internal Shut-Off Temp. Plus/Minus 10 Degrees	Reset Temperature Plus/Minus 10 Degrees
DFA50	176°F/80°C	122°F/50°C
DFA80T	158°F/70°C	104°F/40°C
DFA135C	158°F/70°C	104°F/40°C
DFA180CV	230°F/110°C	194°F/90°C
DFA220CV	194°F/90°C	140°F/60°C

B. Electrical System Protection : This heater’s electrical system is protected by a fuse mounted to the PCB assembly that protects it and other electrical components from damage. If your heater fails to operate check this fuse first and replace as needed.

FUSE TYPE:	All Models	125 volt / 8 amps
-------------------	------------	-------------------

C. Flame-Out Sensor : Utilizes a photocell to monitor the flame in burn chamber during normal operation. It will cause the heater to shut-off should the burner flame extinguish.

**NEVER LEAVE THE HEATER
UNATTENDED WHILE BURNING!**

6. FUELING YOUR HEATER

**NEVER FILL THE HEATER FUEL TANK IN THE LIVING SPACE : FILL THE TANK OUTDOORS.
DO NOT OVERFILL YOUR HEATER AND BE SURE HEATER IS LEVELED.
IMPORTANT NOTICE REGARDING FIRST IGNITION OF HEATER :**

The first time you light the heater, it should be done outdoors. This allows the oils, etc. used in manufacturing the heater to burn off outside.

⚠ WARNING!! : NEVER REFILL HEATER FUEL TANK WHEN HEATER IS OPERATING OR STILL HOT.

7. OPERATION

A.) VENTILATION

RISK OF INDOOR AIR POLLUTION/USE HEATER ONLY IN WELL VENTILATED AREAS.

Provide a fresh air opening of at least three square feet (2,800 sq. cm) for each 100,000 BTU/Hr. rating. Provide extra fresh air if more heaters are being used.

Example :

A DFA220CV heater requires one of the following:

- a two-car garage door raised six inches (15.24 cm)
- a single-car garage door raised nine inches (22.86 cm)
- two, thirty-inch (76.20 cm) windows raised fifteen inches (38.1 cm)

B.) OPERATION

TO START HEATER

1. Fill fuel tank with fuel.

NOTE : Kerosene is recommended when the temperature drops below 0°F(-18°C) to prevent ignition delay or failure.

2. Attach fuel cap.
3. Plug power cord of heater into three-prong, grounded extension cord. Extension cord must be at least six feet long. Extension Cord Wire Size Requirements
 - 6 to 100 feet (1.8 to 30.5 meters) long, use 16 AWG conductor.
 - 101 to 200 feet (30.8 to 61 meters) long, use 14 AWG conductor.
4. Turn “THERMOSTAT CONTROL knob” to desired setting (setting range : 40°F ~ 110°F) (DFA80T/135C/180CV/220CV Models Only)
5. Push “BTU control Switch” to “High” level. (See Figure 8.) (DFA180CV/220CV Models Only)
6. Push Power Switch to “ON” position, Power Indicator Lamp will light and heater will start.
7. After startup, push “BTU control switch” to desired level “High or Low”

NOTE : Room Temperature display explanations are as follows: (DFA135C/180CV/220CV Models only)

- When the room temperature is less 0°F, the LED display will show “Lo”
- When room temp is between 0°F and 99°F, the number shown on the display is the current room temperature.
- When room temperature is greater than 99°F, the LED display will show “Hi”

If heater does not start, the thermostat setting may be too low, turn “thermostat Control Knob” to higher position to start heater. If heater still does not start, turn power switch to “OFF” and then to “ON” position. If heater still does not start, see Troubleshooting Guide on page15.

NOTE : User can select to operate the heater on two different BTU levels(High or Low).

To stabilize heater and prevent ignition delay, select BTU level after turning the heater on, or while it is in operation by pushing the BTU control switch. If the heater started at low BTU level in cold weather or low fuel tank, ignition failure can occur.

NOTE : In cold weather, ignition may be improved by holding a finger over the end of the relief valve or block fanguard in half with newspaper etc. until the heater ignites.

NEVER LEAVE THE HEATER UNATTENDED WHILE BURNING!

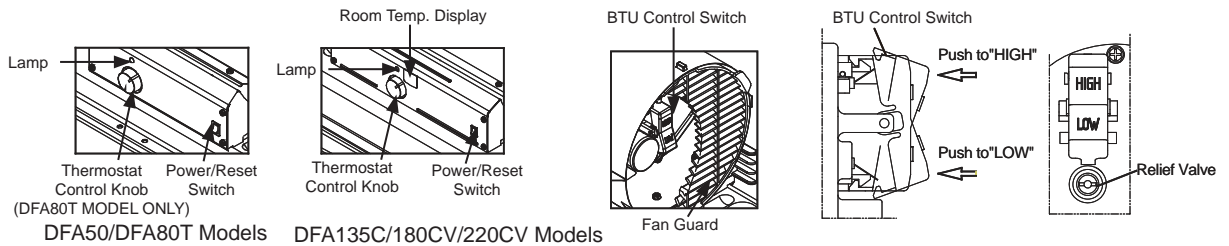

Figure 8. Controls for All Models

NOTICE : The major electrical components of this heater are protected by a safety fuse mounted to the PCB board. If your heater fails to start, check this fuse first and replace as necessary. You should also check your power source to insure that proper voltage and frequency are being supplied to the heater.

TO STOP HEATER

1. Turn switch to “OFF” and unplug power cord.

TO RESTART HEATER

1. Wait 10 seconds after stopping heater.
2. Repeat steps under to start heater.

PIGGYBACK POWER CORD

▲ WARNING : SHOCK HAZARD!

- Always cover electric outlet when not in use.
- Don’t plug and use an appliance more than 120V/60Hz 5A current in this outlet.

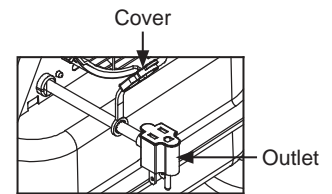

DFA80T/DFA135C/DFA180CV/DFA220CV Models only

Figure 9. Piggyback Power Cord

8. LONG TERM STORAGE OF YOUR HEATER

FUEL TANK DRAIN

1. Drain fuel tank through fuel cap opening. (For DFA50/DFA80T Models Only)
2. Remove fuel drain bolt from rear bottom side of fuel tank using 3/4” socket or adjustable wrench and drain. (For DFA135C/DFA180CV/DFA220CV Models Only. See Figure 10)
3. Using a small amount of kerosene, swirl and rinse the inside of the tank.

NEVER mix water with the kerosene as it will cause rust inside the tank.

Pour the kerosene out making sure that you remove it all.

IMPORTANT : Do not store kerosene over summer months for use during next heating season.

Using old fuel could damage heater.

4. Reinstall fuel cap. Properly dispose of old and dirty fuel. (For DFA50/DFA80T Models Only)
5. Reinstall fuel drain bolt to Fuel tank and tighten firmly using 3/4” socket or adjustable wrench. (DFA135C/DFA180CV/DFA220CV Models Only. See Figure 10)

IMPORTANT : Before reinstalling the fuel drain bolt, make sure the seal is on the bolt. If the seal is not used the bolt cannot be installed correctly and the fuel tank will leak.

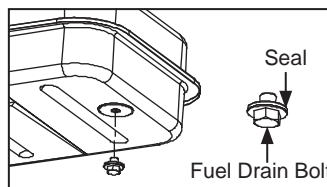

Figure 10. Drain Bolt

6. Store heater in dry well ventilated area. Make sure storage place is free of dust and corrosive fumes.
7. Store the heater in the original box with the original packing material and keep the USER’S MANUAL with the heater.

**NEVER LEAVE THE HEATER
UNATTENDED WHILE BURNING!**

9. MAINTENANCE

⚠ WARNING!! : NEVER SERVICE HEATER WHILE IT IS PLUGGED IN OR WHILE HOT!

USE ORIGINAL EQUIPMENT REPLACEMENT PARTS. Use of third party or other alternate components will void warranty and may cause unsafe operating conditions.

A.) FUEL TANK

FLUSH EVERY 200 HOURS OF OPERATION OR AS NEEDED (SEE STORAGE, PAGE 9)

B.) AIR INTAKE FILTER

WASH AND DRY WITH SOAP AND WATER EVERY 500 HOURS OF OPERATION OR AS NEEDED.

- Remove screws along each side of heater using medium phillips screwdriver.
- Lift upper shell off.
- Remove fan guard.
- Wash or replace air intake filter.
- Reinstall fan guard and upper shell.

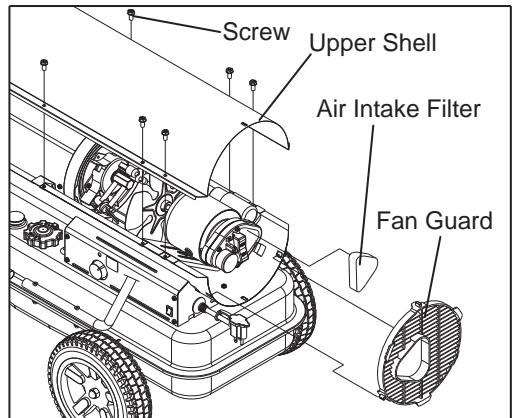

Figure 11. Air Intake Filter Access

C.) AIR OUTPUT FILTER, LINT FILTER

REPLACE EVERY 500 HOURS OF OPERATION OR ONCE A YEAR.

- Remove upper shell and fan guard (See Air Intake Filter).
- Turn Air pressure gauge counter-clock wise and remove.
- Remove end filter cover screws using medium phillips screwdriver.
- Remove end filter cover.
- Replace air output and lint filter.
- Reinstall end filter cover and air pressure gauge.
- Reinstall fan guard and upper shell.

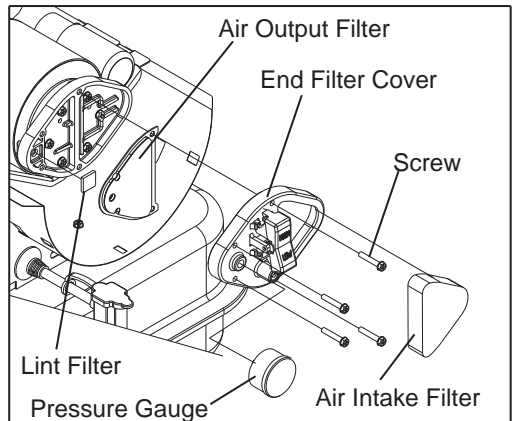

Figure 12. Air Output Filter Access

D.) FAN BLADES

CLEAN EVERY SEASON OR AS NEEDED.

- Remove upper shell (See Air Intake Filter).
- Use M6 allen wrench to loosen set screw which holds fan blade to motor shaft.
- Slip fan blade off motor shaft.
- Clean fan blade using a soft cloth moistened with kerosene or solvent.
- Dry fan blade thoroughly.
- Reinstall fan blade on motor shaft. Place fan blade hub flush with end of motor shaft.
- Place set screw on flat of shaft. Tighten set screw firmly (40-50 inch-pounds/4.5-5.6 N-m).
- Reinstall upper shell.

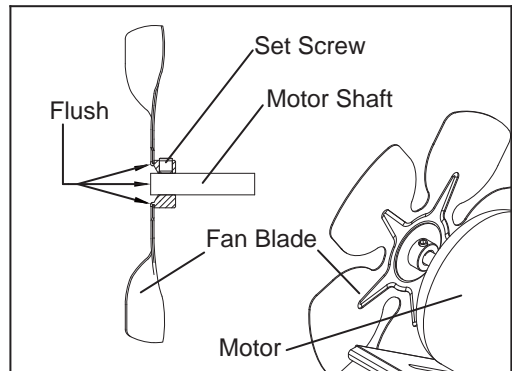

Figure 13. Fan Assembly

NEVER LEAVE THE HEATER UNATTENDED WHILE BURNING!

E.) NOZZLE

REMOVE DIRT IN NOZZLE AS NEEDED (SEE PAGE 16).
(For DFA50/80T/135C/180CV Models Only)

- Remove upper shell (See page 10).
 - Remove fan blade (See page 10).
 - Remove fuel and air line hoses from nozzle adaptor.
 - Remove ignitor wire from spark plug.
 - Remove spark plug from nozzle adaptor using medium phillips screwdriver.
 - Turn nozzle adaptor 1/9 turn(40°) to counter clock wise and pull toward motor to remove. (See Figure 14)
 - Place plastic hex-body into vise and lightly tighten.
 - Carefully remove nozzle from nozzle adaptor using 5/8" socket wrench.
 - Blow compressed air through face of nozzle. (this will remove any dirt in nozzle)
 - Reinstall nozzle into nozzle adaptor until nozzle seats. Tighten 1/3 turn more using 5/8" socket wrench. (40~45 inch-pounds)
 - Reinstall nozzle adaptor to burner head.
 - Reinstall spark plug to nozzle adaptor.
 - Attach ignitor wire to spark plug.
 - Attach fuel and air line hoses to nozzle adaptor.
 - Reinstall fan blade and upper shell.
- (For DFA220CV Model Only)

- Remove upper shell (See page 10).
- Remove fan (See page 10).
- Remove fuel and air line hoses from nozzle adaptor.
- Remove ignitor wire from spark plug.
- Remove spark plug from nozzle adaptor using medium phillips screwdriver.
- Turn nozzle adaptor 1/8 turn (45°) to counter clock wise and pull toward motor to remove. (See Figure 15)
- Place plastic hex-body into vise and lightly tighten.
- Carefully remove nozzle from nozzle adaptor using 5/8" socket wrench.
- Blow compressed air through face of nozzle. (this will remove any dirt in nozzle)
- Reinstall nozzle into nozzle adaptor until nozzle seats. Tighten 1/3 turn more using 5/8" socket wrench (40~45 inch-pounds)
- Reinstall nozzle adaptor to burner bracket
- Reinstall spark plug to nozzle adaptor.
- Attach ignitor wire to spark plug.
- Attach fuel and air line hoses to nozzle adaptor.
- Reinstall fan blade and upper shell. firmly (40-50 inch-pounds/4.5-5.6 N-m).
- Reinstall upper shell.

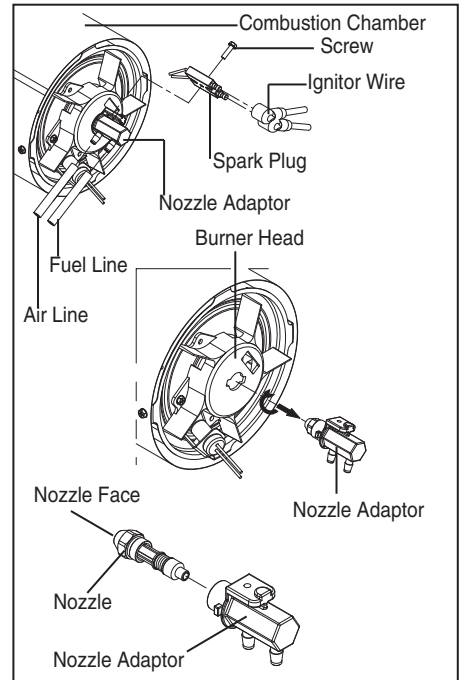

Figure 14. Nozzle Replacement

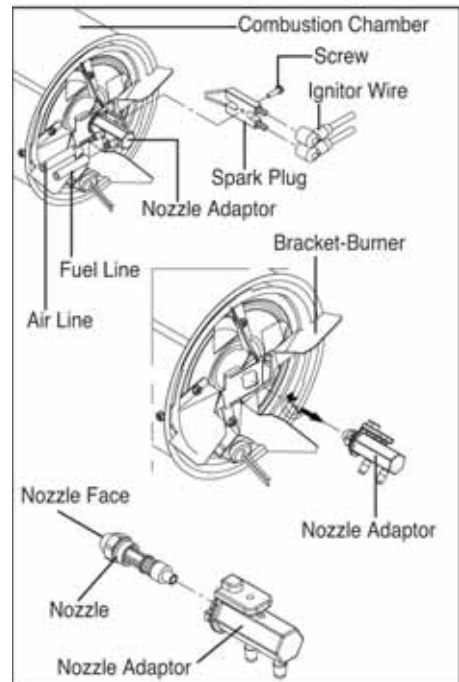

Figure 15. Nozzle Replacement

NEVER LEAVE THE HEATER UNATTENDED WHILE BURNING!

F.) SPARK PLUG

CLEAN AND REGAP EVERY 600 HOURS OPERATION OR REPLACE AS NEEDED.

(For DFA50/80T/135C/180CV Models Only)

- Remove upper shell (See page 10).
- Remove fan (See page 10).
- Remove ignitor wire from spark plug.
- Remove spark plug from nozzle adaptor using medium phillips screwdriver.
- Clean and regap spark plug electrodes to 3.5mm gap.
- Reinstall spark plug to nozzle adaptor.
- Attach ignitor wire to spark plug.
- Reinstall fan and upper shell.

(For DFA220CV Model Only)

- Remove upper shell (See page 10).
- Remove fan (See page 10).
- Remove ignitor wire from nozzle adaptor.
- Remove spark plug from nozzle adaptor using medium phillips screwdriver.
- Clean and regap spark plug electrodes to 3.5mm gap. (0.138")
- Reinstall spark plug to nozzle adaptor.
- Attach ignitor wire to spark plug.
- Reinstall fan and upper shell.

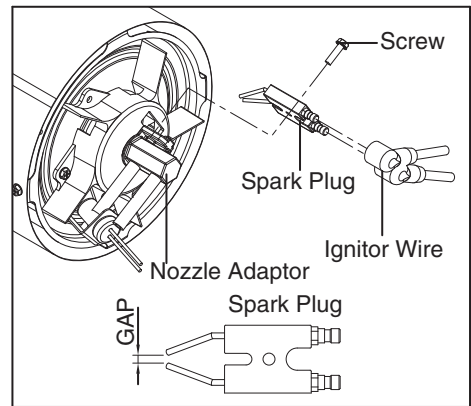

Figure 16. Spark Plug Regap

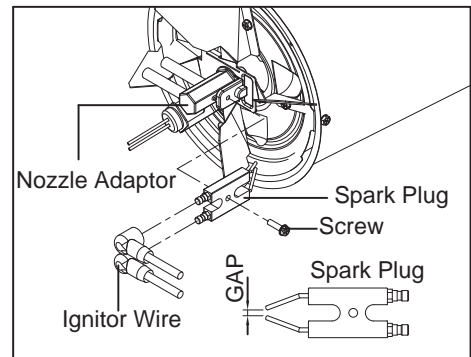

Figure 17. Spark Plug Regap

G.) PHOTOCELL

CLEAN PHOTOCELL ANNUALLY OR AS NEEDED.

- Remove upper shell (See page 10).
- Remove fan (See page 10).
- Remove photocell from it's mounting.
Clean photocell lens with cotton swab.

TO REPLACE:

- Remove side cover screws using medium phillips screwdriver.
- Disconnect switch wires from power switch and remove side cover.
- Disconnect wires from circuit board and remove photocell.
- Install new photocell and connect wires to circuit board.
- Replace switch wires to power switch and side cover.
- Replace fan and upper shell.

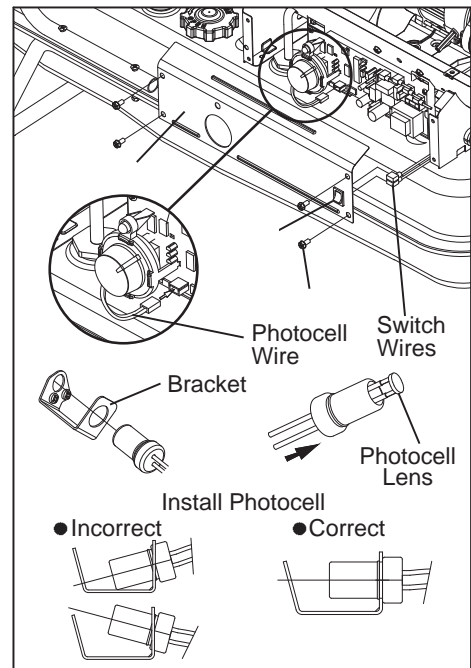

Figure 18. Photocell Replacement

NEVER LEAVE THE HEATER UNATTENDED WHILE BURNING!

H.) FUEL FILTER

CLEAN OR REPLACE TWICE A HEATING SEASON OR AS NEEDED.

- Remove side cover screws using medium phillips screwdriver.
- Disconnect switch wires from power switch and remove side cover.
- Pull fuel line off fuel filter neck.
- Turn fuel filter 90° to counter clockwise and pull to remove (DFA50/80T Models only).
- Turn fuel filter 90° to clockwise and pull to remove (DFA135C/180CV/220CV Models only).
- Wash fuel filter with clean fuel and replace in tank.
- Attach fuel line to fuel filter neck.
- Replace switch wires to power switch.
- Reinstall side cover.

I.) PUMP PRESSURE ADJUSTMENT

NOTE: If the pump pressure needs to be adjusted, make sure the heater is running on the HIGH BTU setting.

- Push the BTU CONTROL Switch to HIGH. (See Operation, page 8, DFA180CV/220CV Models only)
- Remove Pressure Gauge Plug from End Filter Cover. Install accessory Pressure Gauge. (DFA50/80T/135C Models only)
- Start heater (See Operation, page 8)
Allow motor to reach full speed
- Adjust pressure (Using a flat blade screwdriver) Turn relief valve to clockwise to increase pressure. Turn relief valve to counter clockwise to decrease pressure.
- Stop heater (See Operation, page 8)

MODEL	Pump Pressure	
	High BTU level	Low BTU level
DFA50	3.8 psi	N/A
DFA80T	3.8 psi	N/A
DFA135C	5.5 psi	N/A
DFA180CV	6.5 psi	4.5 psi
DFA220CV	8.5 psi	6.5 psi

NOTE: USE ONLY ORIGINAL EQUIPMENT REPLACEMENT PARTS.

Use of alternate or third party components will void any warranty and may cause unsafe operating condition.

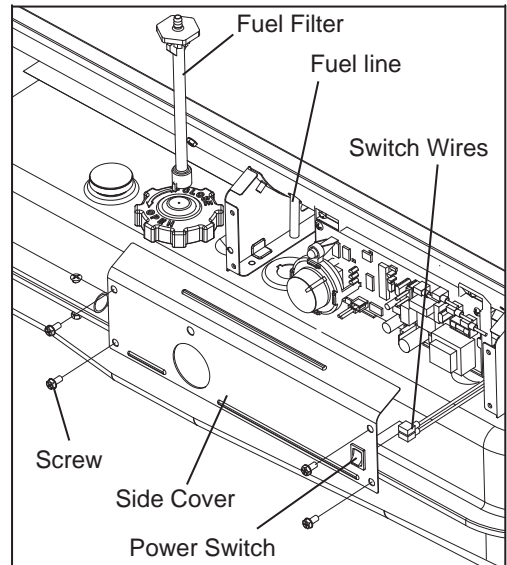

Figure 19. Fuel Filter Replacement

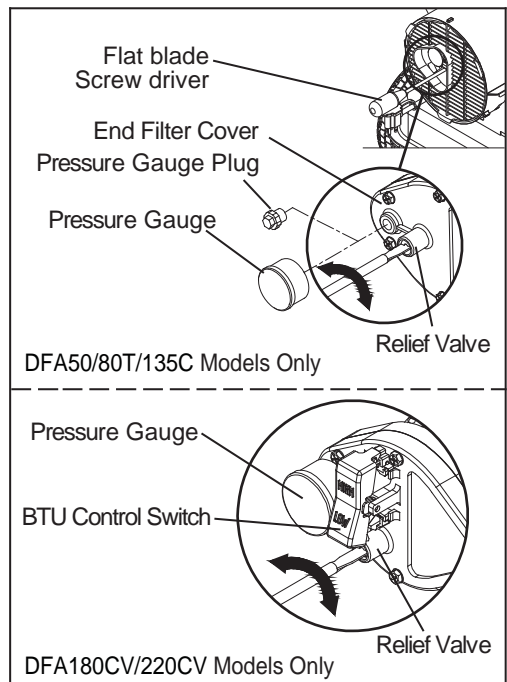

Figure 20. Adjusting Pump Pressure

**NEVER LEAVE THE HEATER
UNATTENDED WHILE BURNING!**

10. REPLACING FUSE

NOTICE : This heater is fuse protected.

If your heater fails to ignite, DO NOT RETURN YOUR HEATER TO THE STORE.

Please follow the simple instructions below to inspect and change the fuse.

PROCEDURE FOR REPLACING FUSE

⚠ WARNING : SHOCK HAZARD

To prevent personal injury, unplug the power cord before replacing fuse.

1. Unplug heater.
2. Remove side cover screws using medium phillips screw driver.
3. Disconnect switch wires from power switch.
4. Remove fuse from fuse holder.(See Figure 21.)
5. Replace fuse.

⚠ WARNING : FIRE HAZARD

To avoid fire, Do not substitute with a higher or lower current rating.

6. Replace switch wires to power switch.
7. Replace side cover.

NOTE : Specified fuse rating : AC 125/8A

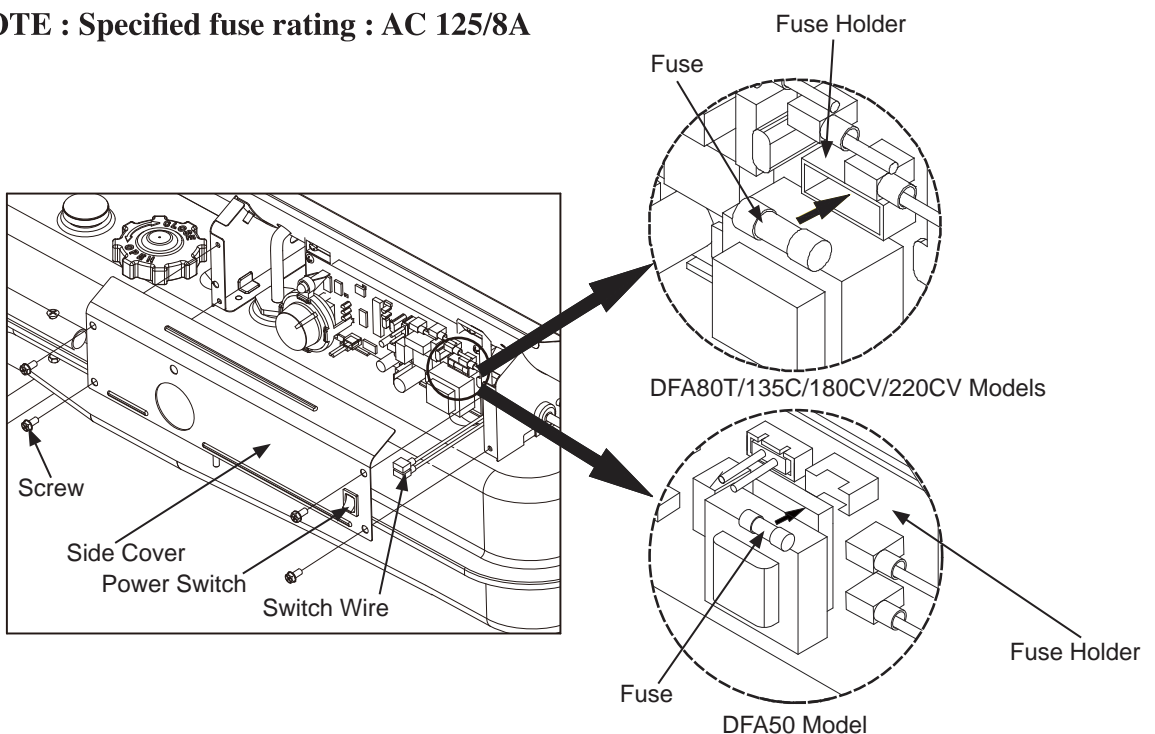

Figure 21. Replacing Fuse

**NEVER LEAVE THE HEATER
UNATTENDED WHILE BURNING!**

11. TROUBLESHOOTING GUIDE

TROUBLE	POSSIBLE CAUSE	CORRECTIVE ACTION
<p>Heater ignites but MAIN PCB assembly shuts heater off after a short period of time. (Indicator Lamp is flickering and room temp. display indicates “E1 “)</p>	<ol style="list-style-type: none"> 1. Wrong pump pressure. 2. Dirty Air Output, Air Intake or Lint Filter. 3. Dirty Fuel Filter. 4. Dirt in Nozzle. 5. Dirty Photocell Lens. 6. Photocell Assembly not Properly installed.(Not seeing the flame) 7. Bad electrical connection between photocell and MAIN PCB assembly. 8. Defective Photocell. 	<ol style="list-style-type: none"> 1. See Pump Pressure Adjustment, Page 13. 2. See Air Output, Air intake and Lint Filters, page 10. 3. See Fuel Filter, Page 13. 4. See Nozzle, Page 11. 5. Clean Photocell Lens, Page 12. 6. Make sure photocell boot is properly seated in bracket, Page 12. 7. Check electrical components See wiring diagram, Page 16. 8. Replace Photocell, Page 12.
<p>Heater will not ignite but motor runs for a short period of time.(Indicator Lamp is flickering and room temp.display indicates “E1 “)</p>	<ol style="list-style-type: none"> 1. No fuel in tank. 2. Wrong pump pressure. 3. Carbon deposits on spark plug and/ or improper gap. 4. Dirty fuel filter. 5. Dirt in Nozzle. 6. Water in fuel tank. 7. Bad electrical connection between ignitor and MAIN PCB assembly. 8. Ignition wire is not attached to spark plug. 	<ol style="list-style-type: none"> 1. Fill tank with kerosene. 2. See Pump Pressure Adjustment, Page 13. 3. See Spark Plug, Page 12. 4. See Fuel Filter, Page 13. 5. See Nozzle, Page 11. 6. Flush fuel tank with clean kerosene, Page 9. 7. Check electrical components See wiring diagram, Page 16. 8. Attach ignition wire to spark plug. See Spark Plug, Page 12.
<p>Fan does not turn when heater is plugged in and power switch was in the “ ON “ Position. (Indicator Lamp is on or flickering)</p>	<ol style="list-style-type: none"> 1. Thermostat setting is too low. 2. Bad electrical connection between motor and MAIN PCB assembly. 	<ol style="list-style-type: none"> 1. Turn thermostat control knob to a higher setting. 2. Check electrical connections, See Wiring Diagram, Page 16.
<p>(Indicator Lamp is flickering and room temp. display indicates “E2”)</p>	<ol style="list-style-type: none"> 1. Sensor Failure. 	<ol style="list-style-type: none"> 1. Replace sensor. See Wiring diagram, Page 16.
<p>(Indicator Lamp is flickering and room temp. display indicates “E3”)</p>	<ol style="list-style-type: none"> 1. Thermostat switch failure. 	<ol style="list-style-type: none"> 1. Replace switch. See Wiring diagram, Page 16.
<p>Heater will not turn-on (Indicator Lamp is off)</p>	<ol style="list-style-type: none"> 1. Temperature limit safety device is overheated. 2. No electrical power 3. Blown fuse. 4. Bad electrical connection between temperature limit safety device and PCB board. 	<ol style="list-style-type: none"> 1. Turn power switch to “OFF” and allow to cool (about 10 min.) 2. Check to insure heater cord and extension cord are plugged in. Check power supply. 3. Replace safety fuse in PCB board. 4. Check electrical connections See Wiring Diagram, Page 16.

NEVER LEAVE THE HEATER UNATTENDED WHILE BURNING!

12. WIRING DIAGRAM

A) WIRING DIAGRAM (DFA50 Model)

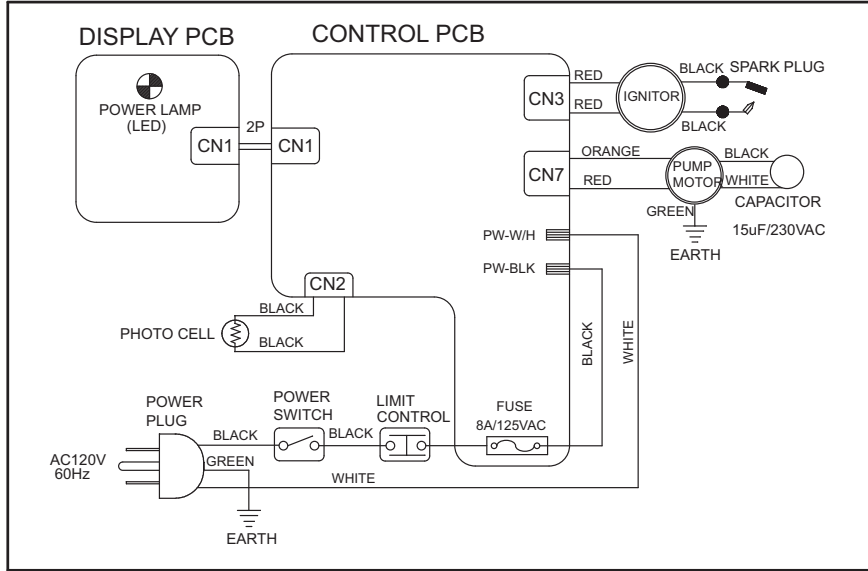

B) WIRING DIAGRAM (DFA80T/135C/180CV/220CV Models)

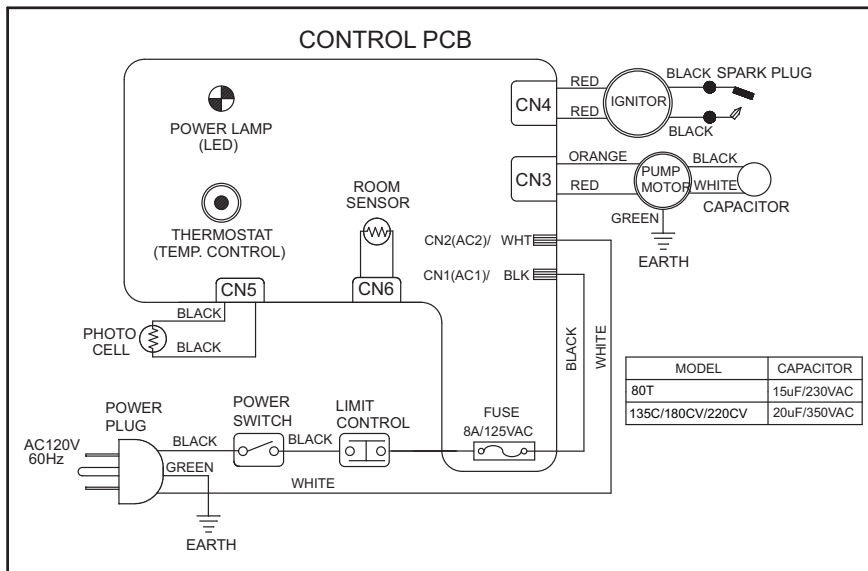

**NEVER LEAVE THE HEATER
UNATTENDED WHILE BURNING!**

13. SPECIFICATIONS

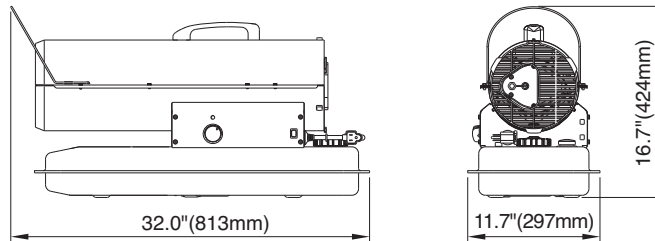

DFA50 / DFA80T Models

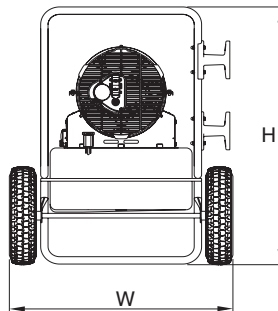
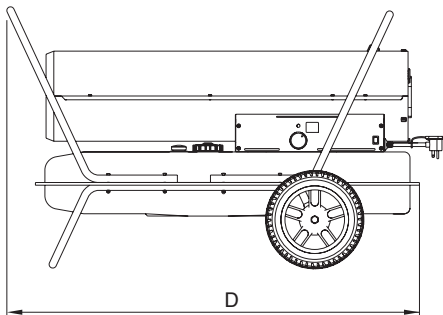

	DFA135C	DFA180CV DFA220CV
D	36.1"(918mm)	41.8"(1,062mm)
W	21.5"(547mm)	23.1"(587mm)
H	24.6"(625mm)	26.1"(664mm)

DFA135C / DFA180CV / DFA220CV Models

MODEL		DFA50	DFA80T	DFA135C	DFA180CV	DFA220CV
BTU/Hr.	HIGH	50,000	80,000	135,000	180,000	220,000
	LOW	N/A	N/A	N/A	140,000	180,000
Fuel Consumption - Gal./Hr(ℓ./Hr)	HIGH	0.38(1.44)	0.60(2.27)	1.02(3.86)	1.36(5.15)	1.66(6.28)
	LOW	N/A	N/A	N/A	1.06(4.01)	1.36(5.15)
Fuel Tank Capacity - Gal.(ℓ)		5.0(18.9)	5.0(18.9)	10.0(37.9)	13.0(49.2)	13.0(49.2)
Fuel Tank Capacity - Gal.(kgf/cm ²)	HIGH	3.8(0.27)	3.8(0.27)	5.5(0.39)	6.5(0.46)	8.5(0.60)
	LOW	N/A	N/A	N/A	4.5(0.32)	6.5(0.46)
Volt/Hz		120Vac/60hz	120Vac/60hz	120Vac/60hz	120Vac/60hz	120Vac/60hz
Amps.		1.6	1.6	2.5	3.2	3.7
Phase		1	1	1	1	1
Size(D×W×H), Inch(mm)		32.0×11.7×16.7 (813×297×424)	32.0×11.7×16.7 (813×297×424)	36.1×21.5×24.6 (918×547×625)	41.8×23.1×26.1 (1,062×587×664)	41.8×23.1×26.1 (1,062×587×664)
Weight Lbs.(kg)		26.9(12.2)	26.9(12.2)	51.4(23.3)	57.3(26.0)	59.5(27.0)

NEVER LEAVE THE HEATER UNATTENDED WHILE BURNING!

14. EXPLODED PARTS DRAWING (DFA50 / 80T / 135C Models Only)

NOTE : SPECIFY MODEL NUMBER AND PART NUMBER WHEN ORDERING PARTS.

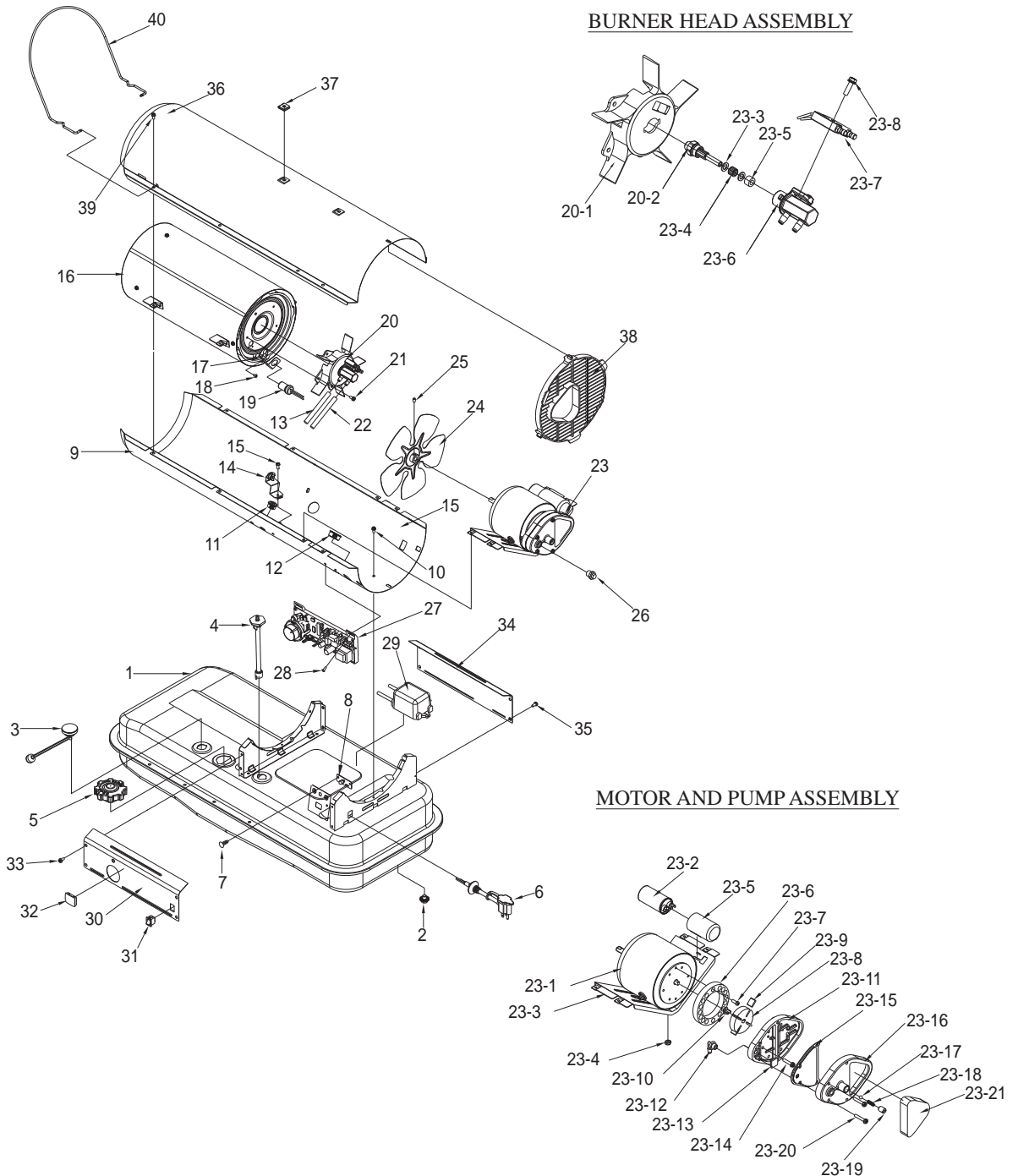

**NEVER LEAVE THE HEATER
UNATTENDED WHILE BURNING!**

14. EXPLODED PARTS DRAWING (DFA220CV Model Only)

NOTE : SPECIFY MODEL NUMBER AND PART NUMBER WHEN ORDERING PARTS.

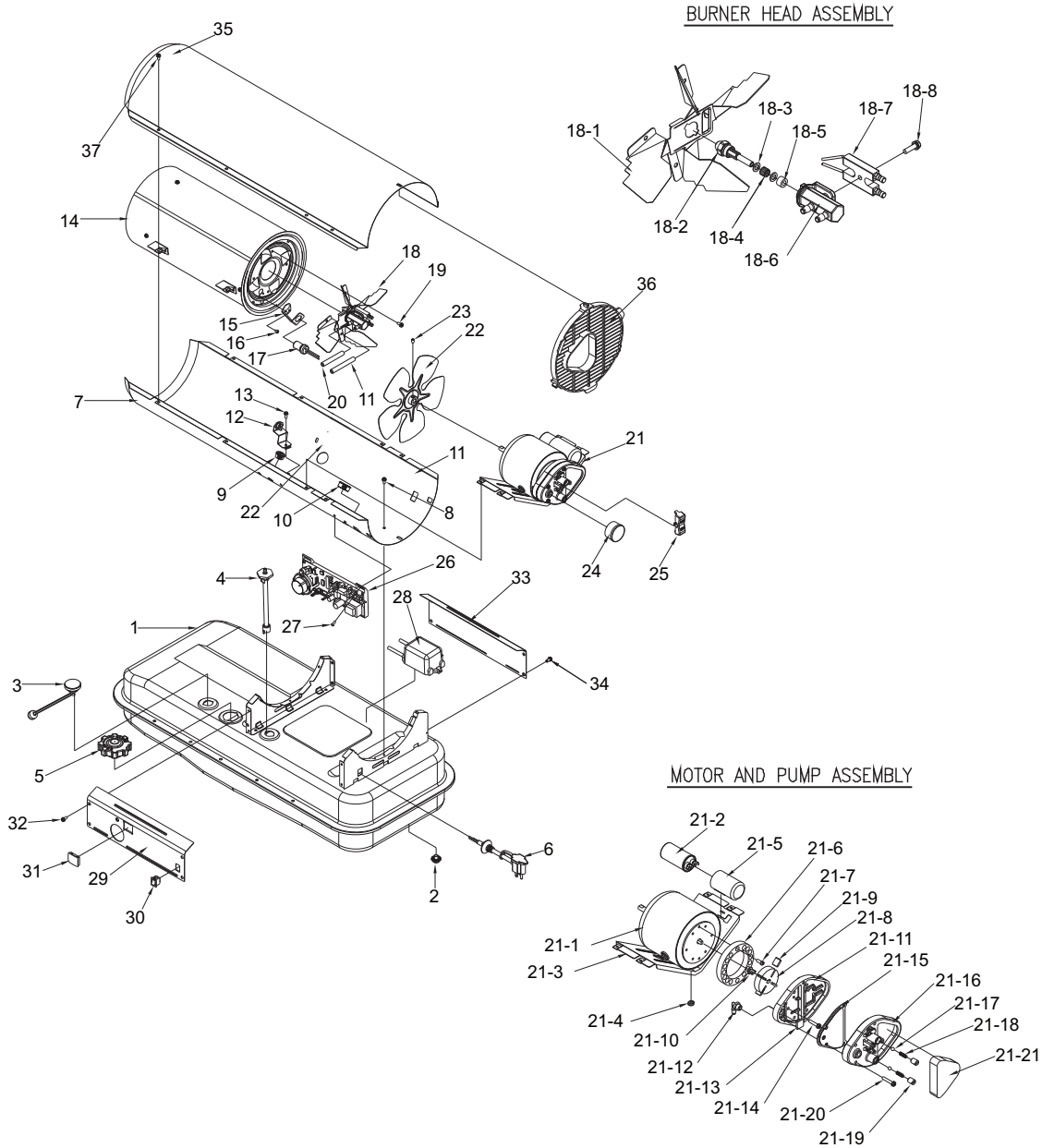

**NEVER LEAVE THE HEATER
UNATTENDED WHILE BURNING!**

15. PARTS LIST (DFA50/80T/135C Models Only)

KEY NO.	DESCRIPTION	PART NO.			QUANTITY
		DFA50	DFA80T	DFA135C	
1	Fuel Tank Assmebly	2151-0046-01	2151-0047-01	2151-0048-01	1
2	Fuel Drain-Bolt	-	-	4329-0072-00	1
3	Fuel Gauge	2156-0047-00	2156-0049-00	2156-0051-00	1
4	Fuel Filter Assmby	2155-0005-00	2155-0005-00	2155-0001-00	1
5	Fuel Cap	2151-0041-00	2151-0041-00	2151-0041-00	1
6	Power Cord	3980-0274-00	3980-0275-00	3980-0275-00	1
7	Button Support	3713-0048-00	-	-	2
8	Display P.C.B Assembly	215A-0013-00	-	-	1
9	Shell Lower	3111-0501-05	3111-0501-05	3111-0506-05	1
10	Flange Screw	4319-0015-00	4319-0015-00	4319-0015-00	4
11	Bushing-Grommet(S)	3231-0120-00	3231-0120-00	3231-0120-00	1
12	Bushing-Grommet(L)	3231-0121-00	3231-0121-00	3231-0121-00	2
13	Air-Line	3341-0035-00	3341-0035-00	3341-0036-00	1
14	Temperature Limit Assembly	2153-0022-00	2153-0013-00	2153-0013-00	1
15	Flange-Screw	4319-0015-00	4319-0015-00	4319-0015-00	1
16	Chamber Assembly	2152-0292-00	2152-0293-00	2152-0294-00	1
17	Bracket Photocell	3131-0159-00	3131-0159-00	3131-0159-00	1
18	Screw-BH1	4311-0068-00	4311-0068-00	4311-0068-00	2
19	Photocell Assembly	*SP-KFA1007	*SP-KFA1007	*SP-KFA1007	1
20	Burner Head Assembly	2152-0120-00	2152-0121-00	2152-0122-00	1
20-1	Burner Head	3531-0026-00	3531-0026-00	3531-0025-00	1
20-2	Nozzle	*SP-KFA1026	*SP-KFA1027	*SP-KFA1003	1
20-3	Washer-Nozzle Seal	4349-0016-00	4349-0016-00	4349-0016-00	2
20-4	Spring-Nozzle Seal	3431-0010-00	3431-0010-00	3431-0010-00	1
20-5	O-Ring	3311-0002-00	3311-0002-00	3311-0002-00	1
20-6	Nozzle Adaptor	3231-0178-00	3231-0178-00	3231-0179-00	1
20-7	Spark Plug	*SP-KFA1008	*SP-KFA1008	*SP-KFA1009	1
20-8	Bolt-Flange	4329-0079-00	4329-0079-00	4329-0079-00	1
21	Flange Screw	4319-0015-00	4319-0015-00	4319-0015-00	3
22	Fuel Line	3341-0034-00	3341-0034-00	3341-0032-00	1
23	Motor and Pump Assembly	2154-0135-00	2154-0135-00	2154-0136-00	1
23-1	Motor	3970-0210-00	3970-0210-00	3970-0211-00	1
23-2	Capacitor	3820-0257-00	3820-0257-00	3820-0258-00	1
23-3	Motor Support	3121-0440-00	3121-0440-00	3121-0439-00	1
23-4	Nut-Hex	4331-0022-00	4331-0022-00	4331-0022-00	2
23-5	Holder Capacitor	-	-	3231-0182-00	1
23-6	Pump Body	3541-0022-00	3541-0022-00	3541-0022-00	1
23-7	Bolt-BH Special	4321-0198-00	4321-0198-00	4321-0198-00	2

**NEVER LEAVE THE HEATER
UNATTENDED WHILE BURNING!**

15. PARTS LIST (DFA50/80T/135C Models Only)

KEY NO.	DESCRIPTION	PART NO.			QUANTITY
		DFA50	DFA80T	DFA135C	
23-8	Rotor	*SP-KFA1000	*SP-KFA1000	*SP-KFA1000	1
23-9	Blade	See SP-KFA1000	See SP-KFA1000	See SP-KFA1000	4
23-10	Insert	See SP-KFA1000	See SP-KFA1000	See SP-KFA1000	1
23-11	End Pump Cover	3531-0027-00	3531-0027-00	3531-0027-00	1
23-12	Elbow	3231-0181-00	3231-0181-00	3231-0181-00	1
23-13	Lint Filter	*SP-KFA1005	*SP-KFA1005	*SP-KFA1005	1
23-14	Bolt Flange	4329-0016-00	4329-0016-00	4329-0016-00	6
23-15	Output Filter	See SP-KFA1005	See SP-KFA1005	See SP-KFA1005	1
23-16	End Filter Cover	3221-0029-00	3221-0029-00	3221-0029-00	1
23-17	Ball	*SP-KFA1006	*SP-KFA1006	*SP-KFA1006	1
23-18	Spring	See SP-KFA1006	See SP-KFA1006	See SP-KFA1006	1
23-19	Adjusting Screw	See SP-KFA1006	See SP-KFA1006	See SP-KFA1006	1
23-20	Bolt Flange	4329-0016-00	4329-0016-00	4329-0016-00	4
23-21	Intake Filter	See SP-KFA1005	See SP-KFA1005	See SP-KFA1005	1
24	Fan Assembly	2154-0009-00	2154-0009-00	2154-0004-00	1
25	Bolt Headless Hex Socket	4323-0004-00	4323-0004-00	4323-0004-00	1
26	Plug	3231-0054-00	3231-0054-00	3231-0054-00	1
27	Main P.C.B Assembly	215A-0048-00	215A-0073-00	215A-0074-00	1
28	Screw-TH2S	4312-0046-00	4312-0046-00	4312-0046-00	2
29	Ignitor	39E0-0071-00	39E0-0071-00	39E0-0071-00	1
30	Side Cover-Right	3121-0496-05	3121-0497-26	3121-0498-18	1
31	Power Switch	39A0-0191-00	39A0-0191-00	39A0-0191-00	1
32	Window Display	-	-	3231-0113-00	1
33	Flange Screw	4319-0015-00	4319-0015-00	4319-0015-00	4
34	Side Cover-Left	3121-0190-00	3121-0350-00	3121-0352-00	1
35	Flange Screw	4319-0015-00	4319-0015-00	4319-0015-00	4
36	Shell Upper	3111-0502-05	3111-0502-05	3111-0507-05	1
37	Clip Nut	3131-0182-00	3131-0182-00	-	2
38	Fan Guard	3221-0074-00	3221-0074-00	3221-0075-00	1
39	Flange Screw	4319-0015-00	4319-0015-00	4319-0015-00	8
40	Front Guard	3561-0066-00	3561-0066-00	-	1

**NEVER LEAVE THE HEATER
UNATTENDED WHILE BURNING!**

15. PARTS LIST (DFA180CV Model Only)

KEY NO.	DESCRIPTION	PART NO.	QUANTITY
		DFA180CV	
1	Fuel Tank Assmebly	2151-0049-01	1
2	Fuel Drain-Bolt	4329-0072-00	1
3	Fuel Gauge	2156-0051-00	1
4	Fuel Filter Assmbly	2155-0001-00	1
5	Fuel Cap	2151-0041-00	1
6	Power Cord	3980-0275-00	1
7	Shell Lower	3111-0508-05	1
8	Flange Screw	4319-0015-00	4
9	Bushing-Grommet(S)	3231-0120-00	1
10	Bushing-Grommet(L)	3231-0121-00	2
11	Air-Line	3341-0038-00	1
12	Temperature Limit Assembly	2153-0023-00	1
13	Flange-Screw	4319-0015-00	1
14	Chamber Assembly	2152-0295-00	1
15	Bracket Photocell	3131-0159-00	1
16	Screw-BH1	4311-0068-00	1
17	Photocell Assembly	*SP-KFA1007	1
18	Burner Head Assembly	2152-0123-00	1
18-1	Burner Head	3531-0024-00	1
18-2	Nozzle	*SP-KFA1004	1
18-3	Washer-Nozzle Seal	4349-0016-00	2
18-4	Spring-Nozzle Seal	3431-0010-00	1
18-5	O-Ring	3311-0002-00	1
18-6	Nozzle Adaptor	3231-0179-00	1
18-7	Spark Plug	*SP-KFA1009	1
18-8	Bolt-Flange	4329-0079-00	1
19	Flange Screw	4319-0015-00	3
20	Fuel Line	3341-0034-00	1
21	Motor and Pump Assembly	2154-0142-00	1
21-1	Motor	3970-0212-00	1
21-2	Capacitor	3820-0258-00	1
21-3	Motor Support	3121-0439-00	1
21-4	Nut-Hex	4331-0022-00	2
21-5	Holder Capacitor	3231-0182-00	1
21-6	Pump Body	3541-0022-00	1
21-7	Bolt-BH Special	4321-0198-00	2
21-8	Rotor	*SP-KFA1000	1
21-9	Blade	See SP-KFA1000	4

**NEVER LEAVE THE HEATER
UNATTENDED WHILE BURNING!**

15. PARTS LIST (DFA180CV Model Only)

KEY NO.	DESCRIPTION	PART NO.	QUANTITY
		DFA180CV	
21-10	Insert	See SP-KFA1000	1
21-11	End Pump Cover	3531-0027-00	1
21-12	Elbow	3231-0181-00	1
21-13	Lint Filter	*SP-KFA1005	1
21-14	Bolt Flange	4329-0081-00	6
21-15	Output Filter	See SP-KFA1005	1
21-16	End Filter Cover	3221-0076-00	1
21-17	Ball	*SP-KFA1010	2
21-18	Spring	See SP-KFA1010	2
21-19	Adjusting Screw	See SP-KFA1010	2
21-20	Bolt Flange	4329-0016-00	4
21-21	Intake Filter	See SP-KFA1005	1
22	Fan Assembly	2154-0007-00	1
23	Bolt Headless Hex Socket	4323-0004-00	1
24	Pressure Gauge	3740-0049-00	1
25	BTU Control Switch	2154-0070-00	1
26	Main P.C.B Assembly	215A-0074-00	1
27	Screw-TH2S	4312-0046-00	2
28	Ignitor	39E0-0071-00	1
29	Side Cover-Right	3121-0499-36	1
30	Power Switch	39A0-0191-00	1
31	Window Display	3231-0113-00	1
32	Flange Screw	4319-0015-00	4
33	Side Cover-Left	3121-0354-00	1
34	Flange Screw	4319-0015-00	4
35	Shell Upper	3111-0349-01	1
36	Fan Guard	3221-0075-00	1
37	Flange Screw	4319-0015-00	8

**NEVER LEAVE THE HEATER
UNATTENDED WHILE BURNING!**

15. PARTS LIST (DFA220CV Model Only)

KEY NO.	DESCRIPTION	PART NO.	QUANTITY
		DFA220CV	
1	Fuel Tank Assmebly	2151-0049-01	1
2	Fuel Drain-Bolt	4329-0072-00	1
3	Fuel Gauge	2156-0052-00	1
4	Fuel Filter Assmby	2155-0001-00	1
5	Fuel Cap	2151-0041-00	1
6	Power Cord	3980-0275-00	1
7	Shell Lower	3111-0504-05	1
8	Flange Screw	4319-0015-00	4
9	Bushing-Grommet(S)	3231-0120-00	1
10	Bushing-Grommet(L)	3231-0121-00	2
11	Air-Line	3341-0036-00	1
12	Temperature Limit Assembly	2153-0005-00	1
13	Flange-Screw	4319-0015-00	1
14	Chamber Assembly	2152-0302-00	1
15	Bracket Photocell	3131-0159-00	1
16	Screw-BH1	4311-0068-00	2
17	Photocell Assembly	*SP-KFA1007	1
18	Burner Head Assembly	2152-0124-00	1
18-1	Bracket Burner	3121-0477-00	1
18-2	Nozzle	*SP-KFA1011	1
18-3	Washer-Nozzle Seal	4349-0016-00	1
18-4	Spring-Nozzle Seal	3431-0010-00	1
18-5	O-Ring	3311-0002-00	1
18-6	Nozzle Adaptor	3231-0180-00	1
18-7	Spark Plug	*SP-KFA1021	1
18-8	Bolt-Flange	4329-0079-00	1
19	Flange Screw	4319-0015-00	4
20	Fuel Line	3341-0039-00	1
21	Motor and Pump Assembly	2154-0137-00	1
21-1	Motor	3970-0213-00	1
21-2	Capacitor	3820-0258-00	1
21-3	Supportor Motor	3121-0439-00	1
21-4	Nut-Hex	4331-0022-00	2
21-5	Holder Capacitor	3231-0182-00	1
21-6	Pump Body	3541-0050-00	1
21-7	Bolt-BH Special	4321-0198-00	2
21-8	Rotor	*SP-KFA1022	1
21-9	Blade	See SP-KFA1022	4
21-10	Insert	See SP-KFA1022	1
21-11	End Pump Cover	3531-0027-0	1
21-10	Insert	See SP-KFA1022	1
21-11	End Pump Cover	3531-0027-00	1

**NEVER LEAVE THE HEATER
UNATTENDED WHILE BURNING!**

15. PARTS LIST (DFA220CV Model Only)

KEY NO.	DESCRIPTION	PART NO.	QUANTITY
		DFA220CV	
21-12	Elbow	3231-0181-00	1
21-13	Lint Filter	*SP-KFA1005	1
21-14	Bolt Flange	4329-0016-00	6
21-15	Output Filter	See SP-KFA1005	1
21-16	End Filter Cover	3221-0076-00	1
21-17	Ball	*SP-KFA1010	2
21-18	Spring	See SP-KFA1010	2
21-19	Adjusting Screw	See SP-KFA1010	2
21-20	Bolt Flange	4329-0016-00	4
21-21	Intake Filter	See SP-KFA1005	1
22	Fan Assembly	2154-0007-00	1
23	Bolt Headless Hex Socket	4323-0004-00	1
24	Pressure Gauge	3740-0049-00	1
25	BTU Control Switch	2154-0070-00	1
26	Main P.C.B Assembly	215A-0074-00	1
27	Screw-TH2S	4312-0046-00	2
28	Ignitor	39E0-0071-00	1
29	Side Cover-Right	3121-0499-37	1
30	Power Switch	39A0-0191-00	1
31	Window Display	3231-0113-00	1
32	Flange Screw	4319-0015-00	4
33	Side Cover-Left	3121-0354-00	1
34	Flange Screw	4319-0015-00	4
35	Shell Upper	3111-0505-05	1
36	Fan Guard	3221-0075-00	1
37	Flange Screw	4319-0015-00	8

**NEVER LEAVE THE HEATER
UNATTENDED WHILE BURNING!**

15. PARTS LIST (WHEELS AND HANDLE)

1) DFA50/80T MODELS

KEY NO.	DESCRIPTION	PART NO.		QUANTITY
		DFA50	DFA80T	
1	Handle	3231-0073-00	3231-0073-00	1

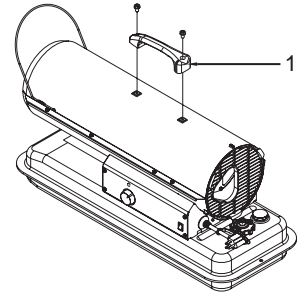

2) DFA135C/180CV/220CV MODELS

KEY NO.	DESCRIPTION	PART NO.		QUANTITY
		DFA135C	DFA180CV / 220CV	
1	Front Handle	3551-0023-00	3551-0022-00	1
2	Rear Handle	3551-0086-00	3551-0087-00	1
3	Wheel Support Frame	3551-0082-00	3551-0084-00	1
4	Wheel	3720-0017-00	3720-0017-00	2
5	Threaded Axle	3551-0088-00	3551-0089-00	1
6	Cord Wrap	-	3221-0042-00	2
7	Hardware Kit	HW-KFA1016	HW-KFA1016	1
7-1	Screw	INCLUDED IN HARDWARE KIT	INCLUDED IN HARDWARE KIT	8
7-2	Flange Screw	INCLUDED IN HARDWARE KIT	INCLUDED IN HARDWARE KIT	4
7-3	Cap Nut S	INCLUDED IN HARDWARE KIT	INCLUDED IN HARDWARE KIT	4
7-4	Nut	INCLUDED IN HARDWARE KIT	INCLUDED IN HARDWARE KIT	8
7-5	Bushing	INCLUDED IN HARDWARE KIT	INCLUDED IN HARDWARE KIT	2
7-6	Cap Nut L	INCLUDED IN HARDWARE KIT	INCLUDED IN HARDWARE KIT	2

