

# TIPS FOR THE ULTIMATE SHRINK WRAP JOB

## CAUTION:

This shrink wrap can burn. If heat is applied incorrectly, shrink wrap can ignite into open flame. It can also drop down on to other combustible material and cause secondary ignition and fire. If at any time you observe the shrink wrap on fire, immediately stop what you are doing and carefully inspect the area where you are working for a possible fire. Keep a fire extinguisher available at all times!

**1 INSTALL SUPPORT STRUCTURE ON YOUR BOAT FOLLOWING THE DIRECTIONS ON THE ENCLOSED TRAINING CD:** Please view the training CD at least twice before shrink wrapping your boat. Follow all necessary safety precautions when using a knife to cut strapping, saw wood and when climbing on any ladders.

## 2 BEFORE INSTALLING WRAP:

- Tape over fuel vents (contact your boat dealer for help in locating fuel vent).
- Pad all sharp objects with foam padding, shrink wrap, tape, etc.
- Be sure that film does not drag on the ground or floor (static electricity in the film attracts dirt and dust which won't allow the film to weld properly).

**3 SHRINKING:** Once the film is on the boat (after you have heat-welded around the perimeter band) there are a few steps that can help in achieving a wrinkle-free, tight cover.

- You must install the belly bands immediately after heat welding around the perimeter band on the boat. These taut straps pull the slack from the wrap allowing it to become tighter when heated.
- The shrinking order is as follows:
  - Seal all pleats in cover, including the bow and stern.
  - Begin applying heat at the bottom of the cover near one end (never in the middle). Guide the shrinking with the heat gun (use it as if you were spray painting) to the other end of the boat, up to the rub rail. Starting at the bottom of the cover allows the heat to rise and helps you shrink more quickly.
  - Now you can shrink the top; be careful not to put excess heat on the corners or sharp protruding objects. Avoiding these areas allows the shrink wrap to maintain its full thickness at these points.

**4 HOLE PATROL:** When the cover is completely shrunk, you must check for burn or puncture holes in the cover. A hole in the shrink wrap will not tear or rip, but will certainly allow the elements into the boat. The most effective method of repairing a hole or weak spot is to use shrink wrap tape which is made of the same materials as the wrap itself. When shrink wrap tape is applied to a hole, or to reinforce over a sharp object, it **MUST** be rubbed to remove air bubbles and activate the adhesives in the tape. The tape should also be lightly warmed using the gun so that the tape will adhere better.

**5 REMOVE TAPE FROM FUEL VENT**

**6 VENTS AND DOORS:** Vents and doors are installed after the cover is completely shrunk. They are not heated onto the cover at all. Vents are self-adhesive and the adhesive on them must be hand warmed and rubbed to have a complete seal. Doors are taped to the cover using either 2" or 4" shrink wrap tape. The door is then unzipped and a hole cut underneath the zippered area.

**Dr.Shrink<sup>+</sup>**  
INTERNATIONAL SHRINK WRAP SUPPLIER



Dr.  
TIPS FROM THE

# SHRINK WRAPPING SAILBOATS

## MAST DOWN

- ▽ Shrink wrapping a sailboat with the mast down uses many of the same principals explained on the training CD which is included with the heat tool kit. Before beginning the covering process, please view the CD at least twice to familiarize yourself with all the steps.

When covering a sailing vessel mast down, the steps listed below must be followed:

- 1** Run strapping fore and aft on the boat from the highest point on the bow (pulpit) to the highest point in the center on the stern (stern rails). Tighten this strap with a buckle by using the included buckle installation instructions.
- 2** Once the strap is tightened you may begin measuring the 2" x 4" wooden uprights that will form your support structure. These wooden uprights are forced under the fore and aft strapping and will give the shrink wrap cover the necessary pitch to allow snow and rain to run off. One upright will be needed in the cockpit and then every 5' – 6' until the bow is reached. If possible, the upright should be lined up between stanchions so a woven cord strap can be run laterally from the top of the stanchion across the top of the upright to the top of the opposing stanchion (this strap will give additional support to the cover and also keep your upright from falling down). The height of the uprights will vary with different boats, but when complete, the center strap must be at least 18" higher than the top of the stanchions. Again, this will give the cover enough slope to allow snow and rain to run off.
- 3** Now, staple the strapping onto the top of the upright where it crosses the fore and aft strap (an Arrow T-50 stapler works great). Pad the tops of the uprights as shown on the CD.
- 4** Once this is completed the rest of the process can be done by following the steps on the CD.

---

## MAST UP

- ▽ Covering a sailboat mast up can seem like a very daunting proposition at first, but it takes only a couple of more steps than shrink wrapping a mast down boat. Following the directions below and watching the training CD at least twice will minimize any problems.

- 1** Install your strapping fore and aft on the boat from the highest points at the bow and stern. The strapping will be tied around the mast from the stern and then around the mast from the bow (if the boom is left on, it can become part of the support structure aft of the mast, but you must put a 2" x 4" upright under the rear of the boom to give it strength). Pull the strapping tight as you normally would, measure and install your wooden uprights as on a mast down boat, put your lateral straps over the wooden uprights, or boom, and pad them.

- 2** Install the perimeter band following the CD instructions.
- 3** Go aboard the boat with a 25' tape measure. Measure from the mast back to the farthest point aft (top of the stern rail). To this figure add 2 feet which will extend aft of the mast and 4 feet that will drape over the bow (a total of 6 extra feet).
- 4** Now measure from the mast forward (top of the bow rail or pulpit). To this figure add on 2 feet which will extend aft of the mast and 4 feet that will drape over the bow (a total of 6 extra feet).
- 5** Next cut your roll of shrink wrap the measurement from the mast back. Roll it up and take it onto the boat. Lay the roll over the support structure or boom and open it enough to measure and find the center. Make a 2' lengthwise slit in the shrink wrap at the center of the wrap. This slit area will be wrapped around the mast to form a collar. Once you have a collar formed, take the roll of heat shrink tape and go around the collar twice very tightly (do not stick tape directly to the mast as there might be an adhesive residue in the spring).
- 6** Unroll the aft section of shrink wrap towards the stern (do not unfold its entire width yet; the wind might catch it). Go aft as far as possible, until you run into the aft stays. Now you can unfold the shrink wrap and have it lay as straight fore and aft, and side to side, as possible. Using your wrap cutting knife make slits in the shrink wrap up to stays and halyards. They should be as neat as possible. Use strips of heat shrink tape to seal them and then apply heat to warm the adhesives (press tape down firmly to remove all air bubbles).
- 7** Trim and tuck the shrink wrap under the perimeter band on the boat so that wind doesn't catch it.
- 8** Now the shrink wrap piece at the bow can be attached. It is done in a similar fashion as the aft piece. Place the measured piece of wrap just forward of the mast; find the center and slice into it 2 feet. Make a collar around the mast tightly and tape around it. Unroll the wrap toward the bow up to the forestay. Slice the wrap to the forestay and roll it over the bow. Tape the slit together and unfold the shrink wrap.
- 9** Run a strip of tape from the mast down to each side of the shrink wrap where the forward and aft pieces meet. Use the heat tool to warm the adhesives in the tape and actually heat weld the pieces of shrink wrap together.
- 10** Trim and tuck the forward piece under the perimeter band. Shrink wrap the boat according to CD.

# FILM SIZES & VENTING



All shrink wrap covers must be ventilated to eliminate moisture, condensation, and mildew during the winter storage season. The number of vents needed to give a boat cross-flow ventilation will depend on the size and shape of the vessel. Remember – it is better to over ventilate the cover with additional vents rather than not installing enough. The following is an idea of the number needed by boat size:

Boat Size	# of Vents	Location
0'-18'	3	Two vents behind windshield and one at rear of cockpit.
19'-24'	4	Two vents in rear of cockpit and two forward of windshield.
25'-32'	6	Two vents in rear of cockpit, two at midsection, and two near bow.
33'-42'	8	Two vents in rear of cockpit, two on fly bridge, two amidship, and two near bow.
43' & Above	8-12	Same as above, with extras along the sides of the craft.

## DS-683 "WEATHER-TIGHT" VENT INSTALLATION PROCEDURES:



1

Completely shrink the cover before installing vents.



2

Vents may be installed on a horizontal or vertical surface. In areas receiving significant snow loads, vertical orientation is best as the vent will be less susceptible to snow cover-up.

3

Clean the cover if it is damp or dirty. Push against the cover to assure there is nothing behind the section you wish to install the vent which could impede air flow or be damaged by cutting (such as a seat cushion).



4

Remove the vent cover by squeezing the ends and remove the paper covering the adhesive backing on the base of the vent.

5

Affix the vent base to desired location and press firmly.

6

Carefully cut out the shrink wrap on the inside edge of the base. Reach inside and compress the shrink wrap against the adhesive base to insure proper adhesion.

7

Reinstall vent cover.

Film Size	Sq. Ft	Boat Length	Beam	# of Boats	# of Vents	Description
12' x 175'	2100	0'-16'	up to 7'	8	4	Works well for finishing boats & boats with low windshields
14' x 150'	2100	14'-19'	up to 8'	6	4	Great for runabout with full windshields
17' x 120'	2040	17'-24'	up to 8.5'	4	6	Excellent for pontoon boats and cuddy cabin cruisers
20' x 100'	2000	25'-29'	up to 8.5'	3	6	Good for express cruisers
24' x 115'	2760	25'-29'	up to 9'	3	6	Superb for express cruisers with arches or small flybridges
26' x 100'	2600	28'-31'	up to 10'	2	8	Very little waste on wider, taller flybridge boats under 32'
32' x 100'	3200	30'-38'	up to 11'	2	10	Super for wide and tall flybridge boats with an arch
40' x 100'	4000	44'-60'	up to 16'	1	12	Covers very large boats with arches and bridges with one piece of wrap
50' x 100'	5000	60'+	16'+	1	16	Excellent one piece coverage for the largest of boats with multiple levels, arches & bridges

## USING THE STRAPPING & BUCKLES

The following is a brief visual explanation of how to use the buckles and strapping system.

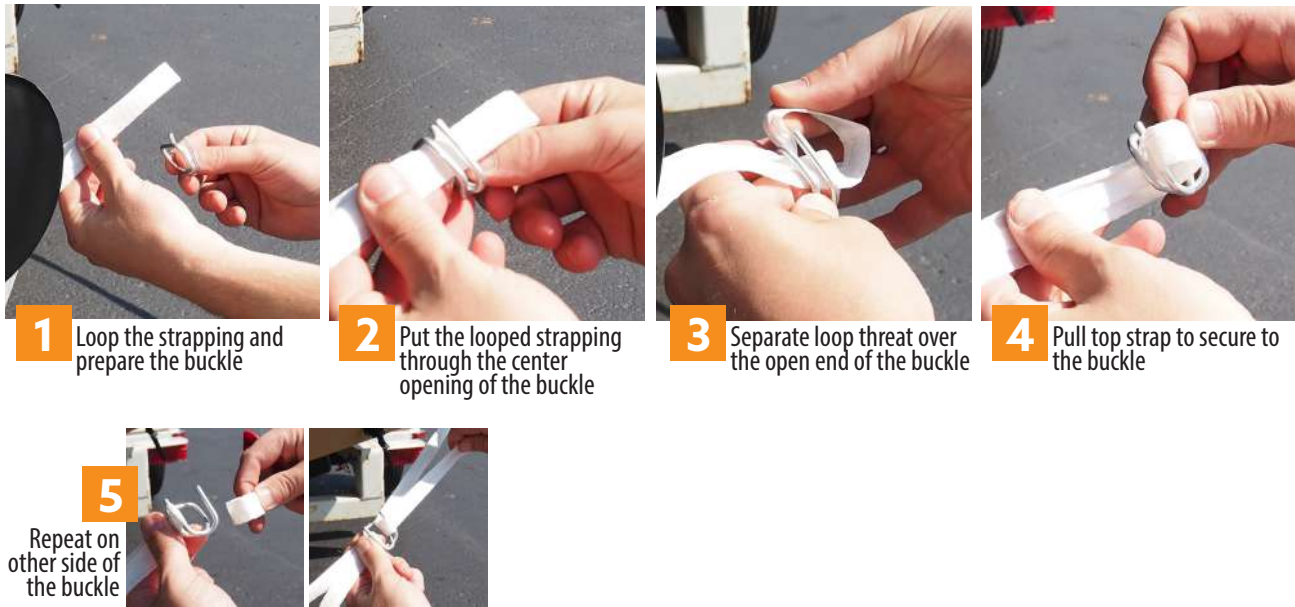

**1** Loop the strapping and prepare the buckle

**2** Put the looped strapping through the center opening of the buckle

**3** Separate loop thread over the open end of the buckle

**4** Pull top strap to secure to the buckle



**5** Repeat on other side of the buckle

### ITEMS PROVIDED BY THE CUSTOMER

The Dr. Shrink "Wrap It Up Kit" is a complete system that provides most of the necessary equipment to shrink wrap your boat except for the following items:

- 1** 20 pound propane tank. This is the same size tank that would be found on a home barbecue.
- 2** Ladders – you must have a sturdy step ladder that is tall enough so you won't have to stand on the upper rungs when you are shrinking the top of the boat cover. An extension ladder works well on larger power boats with fly bridges.
- 3** 25' tape measure
- 4** Handsaw for cutting 2" x 4" boards for your support structure.
- 5** Ring cutter (DS-RCUT) for cutting strapping.
- 6** Six 2" x 4" x 8' boards to be used as wooden uprights under the cover. This is the maximum that you will need; smaller boats will take fewer boards.
- 7** Stapler – an Arrow T-50 with 1/2" staples.
- 8** DVD player or computer to view the training CD. Watch at least twice to familiarize yourself with the techniques and safety procedures.

### THE REBAG® RECYCLING SYSTEM

The Dr. Shrink Rebag® recycling program is a simple, yet effective method of recycling your used shrink wrap boat cover after the storage season. It is made into a replacement for cardboard products and is a very environmentally responsible program. There are just a few easy steps that you must do so the wrap is desirable for recycling:

- 1** Remove the shrink wrap according to the instructions on the label affixed to your cover. There must be no strapping, rope, doors, or foreign material in the shrink wrap.
- 2** Stuff the shrink wrap into the Rebag®. Leave enough room so the bag can be closed with the cable tie included.
- 3** Attach the enclosed prepaid, self-adhesive label to the bag. Take the full bag to the marine dealer where you purchased your shrink wrap. It will be picked up there by our carrier, at no charge to you.
- 4** Thanks for recycling!

# PONTOON BOAT

## 24' SAMPLE BOAT



Pontoon boats are very similar to recreational deep v-hull boats, however, there are a few different tips and tricks we have for you to make your wrapping job quicker and easier. Here we outline ways to measure for your wrap and include details about great add-on's to avoid unnecessary damage to your customer's boat.

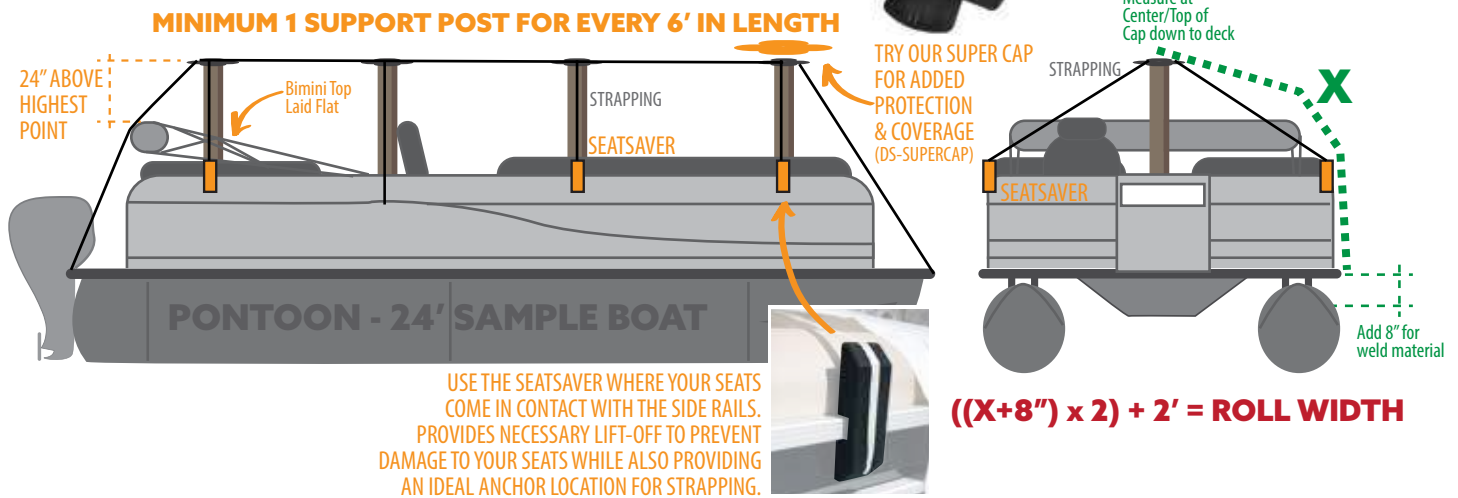

### MEASURING FILM WIDTH - PONTOON BOAT

Start at the highest point on your pontoon boat (at the top of your support post) and measure over the widest part of the boat to about 8" below the beam/perimeter band location as indicated below. Double this measurement and add 2' to the overall measurement. This will give you the narrowest shrink wrap that will be usable on your boat.



### PONTOON VENTING CHART

Shrink Wrap film requires venting for seasonal storage to help minimize the amount of harmful moisture buildup that can occur.

Length	Beam	Film Size	# of Vents
 0'-16'	8'	17' x 110'	4
 16'-22'	8'-9'	18' x 200'	6
 23'-28'	8-11'	20' x 89'	8

### WELD/PERIMETER BAND MATERIAL TIPS



Instead of tucking the shrink wrap film under the perimeter band (like you would with a traditional recreational boat), **the shrink wrap should be put on the boat before the perimeter band strapping.** The perimeter band is then installed over the shrink wrap just below the decking. Once the perimeter band is tightened over the shrink wrap, fold the loose shrink wrap up and heat weld it over the exposed strapping.

## TIPS & RESOURCES

# RECREATIONAL BOAT

## 18' SAMPLE BOAT

The following are some of the most frequently asked questions when shrink wrapping a recreational boat for seasonal storage or transportation. Here we highlight how to properly measure for your roll width while also providing tips to prevent holes with some of the great products offered by Dr. Shrink.



### MEASURING FILM WIDTH & DETERMINING SUPPORT POSTS NEEDED FOR STRUCTURE

Start at the highest point on your boat (at the top of your support post) and measure over the widest part of the boat to about 8" below the rub rail. Double this measurement and add 2' to the overall measurement. This will give you the narrowest shrink wrap that will be usable on your boat.

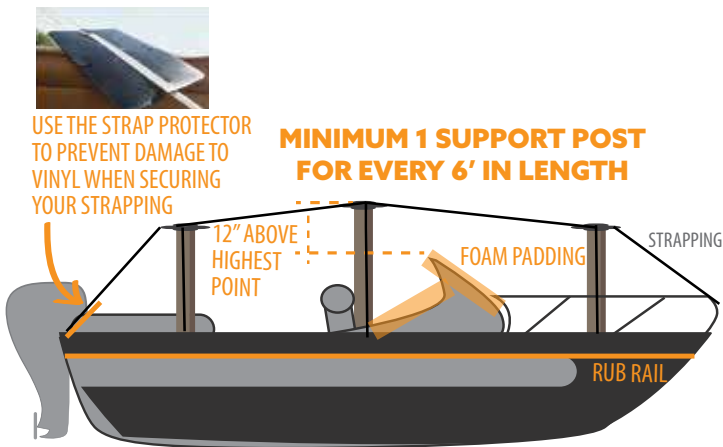

REC. BOAT - SIDE

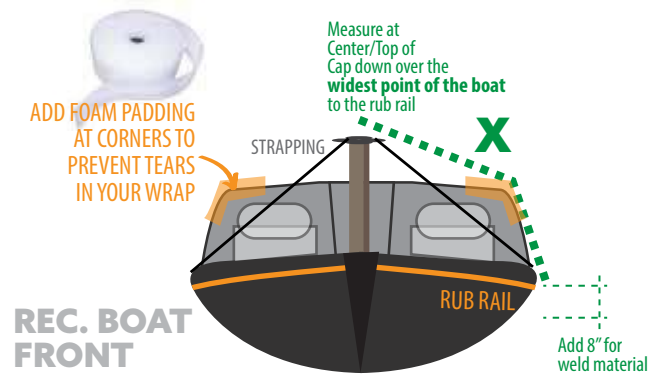

REC. BOAT FRONT

$$((X+8") \times 2) + 2' = \text{ROLL WIDTH}$$

### STRAPPING & BUCKLE TIPS



Tape buckles with heat shrink tape

This step is often overlooked by DIY shrink wrappers. Taped buckles prevent snagging when pulling the shrink wrap over the boat. Save yourself time, in not having to tape holes. Tape your buckles after you tighten the strapping when creating the sub-structure for your shrink wrap project.

### RECREATIONAL BOAT VENTING CHART

Length	Beam	Film Size	# of Vents
0'-16'	7'	12' x 149' 1,788 s.f.	4
14'-19'	8'	14' x 128' 1,792 s.f.	4
17'-24'	8.5'	17' x 110' 1,870 s.f.	6
25'-29'	8.5'	20' x 89' 1,780 s.f.	6
	9'	24' x 120' 2,880 s.f.	6
28'-31'	10'	26' x 100' 2,600 s.f.	8

## TIPS & RESOURCES

# FULL ENCAPSULATION

The following are some of the most frequently asked questions when fully encapsulating and shrink wrapping an object for storage or transportation. Here we highlight how to properly measure for your roll width while also providing tips to prevent holes with some of the great products offered by Dr. Shrink.



## MEASURING FILM SIZE AND CREATING THE ENCAPSULATION

To fully encapsulate an object, you will need to encase it completely in shrink wrap. Here are some quick tips to help you determine your roll widths needed for your project. For illustrative purposes (in both images and our how-to video) we are showing a fork lift being wrapped.

### DETERMINE BASE ROLL WIDTH SIZE STEP #1

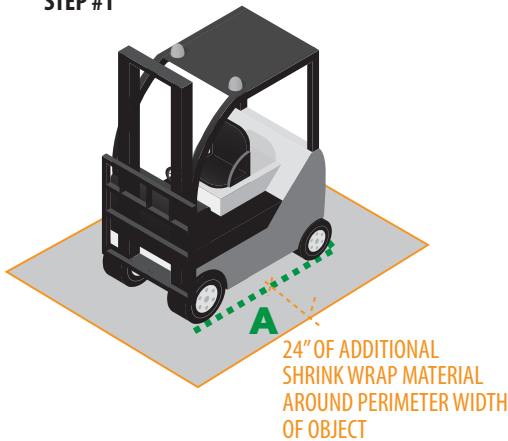

$A + 24" + 24" = \text{BASE WIDTH ROLL SIZE}$

### DETERMINE COVER ROLL WIDTH SIZE STEP #2

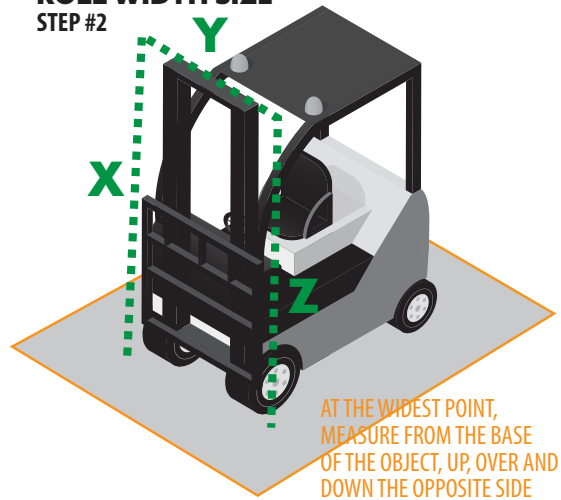

$X + Y + Z = \text{COVER ROLL WIDTH SIZE}$

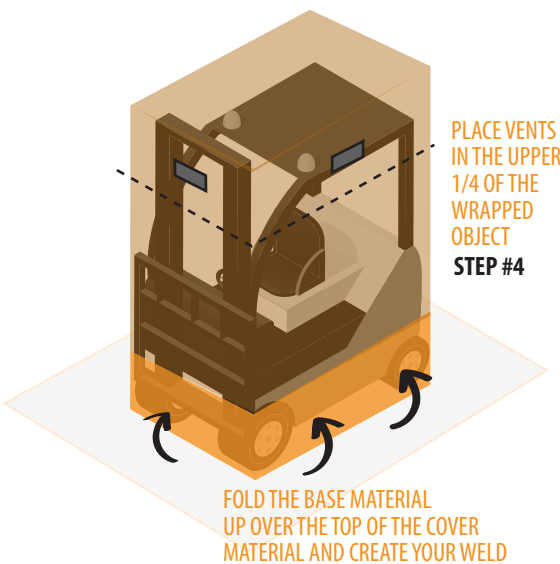

PLACE VENTS IN THE UPPER 1/4 OF THE WRAPPED OBJECT  
STEP #4

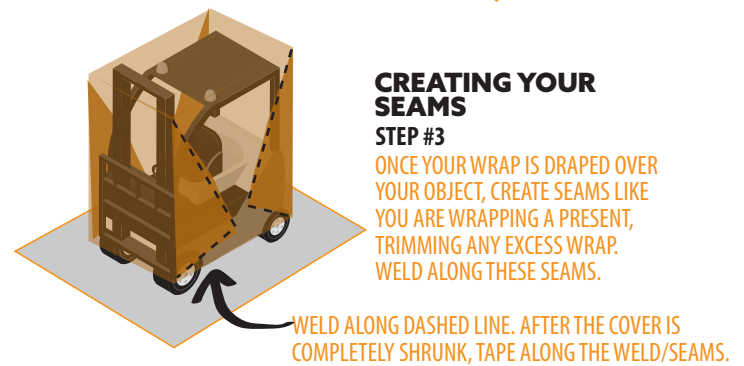

### CREATING YOUR SEAMS STEP #3

ONCE YOUR WRAP IS DRAPED OVER YOUR OBJECT, CREATE SEAMS LIKE YOU ARE WRAPPING A PRESENT, TRIMMING ANY EXCESS WRAP. WELD ALONG THESE SEAMS.



**ENCAPSULATING & YOUR VENT PLACEMENT**



OUR LIFTING LUG COVER IS IDEAL FOR FULL ENCAPSULATION PROJECTS WHEN ACCESS IS NEEDED TO ANCHOR/LIFT POINTS ON THE OBJECTS

# MODULAR UNITS

## FOR TRANSPORTATION & STORAGE

### HOW TO INSTALL SHRINK WRAP ON MODULAR UNITS

1. Pad all sharp objects where the shrink wrap will touch the module—corners, roof edges, ends of rafters, etc., with Dr. Shrink's Foam Padding. Install the padding in a similar fashion as would be done when installing regular plastic transit sheeting.

2. Lay the shrink wrap over the unit leaving at least two feet of material at each end of the roof. If you are covering a hinged roof unit, a 32' wide roll of shrink wrap will allow the roof and marriage wall to be wrapped in one piece. For flat top modules a 28' wide shrink wrap works well.

3. The shrink wrap must be held firmly on all sides so it will shrink properly. **Roll the edge of the shrink wrap one complete turn in furring strips (see detail).** The strips then need to be attached with either double headed nails or staples around the entire perimeter of the shrink wrap. This step is also very similar to installing regular plastic transit sheeting.

4. It is preferred to cover the roof and marriage wall with one piece of shrink wrap to ensure complete weather protection. Once the shrink wrap is firmly attached to the module it can then be shrunk. We recommend our more powerful heat tools such as the Shrinkfast 998 or the Ripack 3000 with extensions. **When heating the shrink wrap cover, begin at the bottom of the module and sweep the heat across the cover. Starting low on the units lets the heat rise to help shrink the upper surface.** After the entire side is shrunk the top may then be heated.

5. After shrinking the entire module it is necessary to do a "hole patrol." There can be small holes that occur from either a bit too much heat or by being poked with staples, nails, sharp corners, etc. Small holes are easily repaired with our heat shrink tape. Always cut the tape rather than ripping it so the ends are clean and will adhere to the shrink wrap much better.

6. The last step is to run a few vertical furring strips along the length of the marriage wall to keep the plastic from billowing. A good formula is to install them about 6-8 feet apart.

7. If access is needed into the module, nail furring strips on both sides of the opening before it is cut. The opening can be repaired with heat shrink tape or a larger piece of plastic taped over the opening. Always lightly heat the tape to warm the adhesives as this makes the tape stick much better.

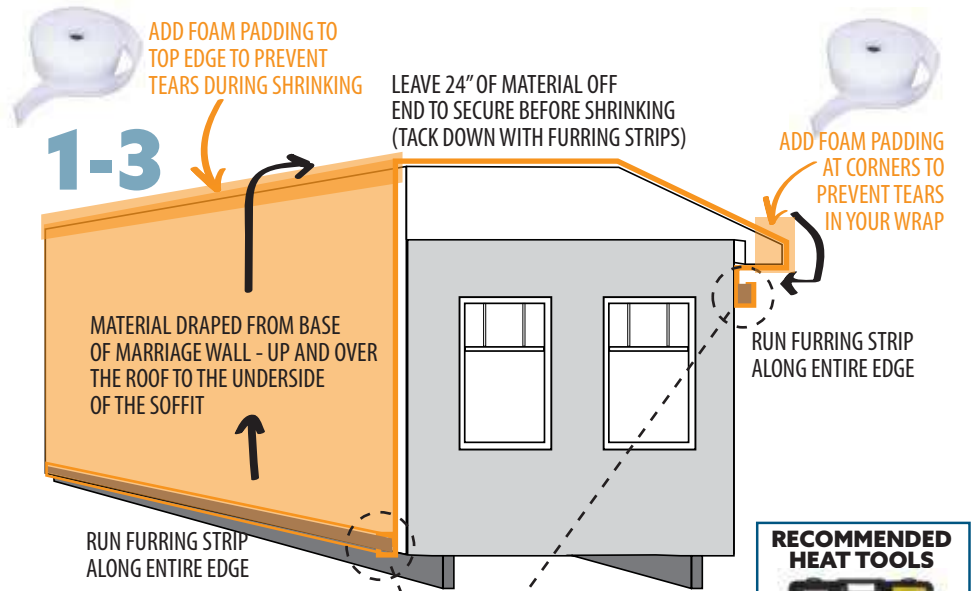

#### SECURING THE FURRING STRIPS PRIOR TO SHRINKING

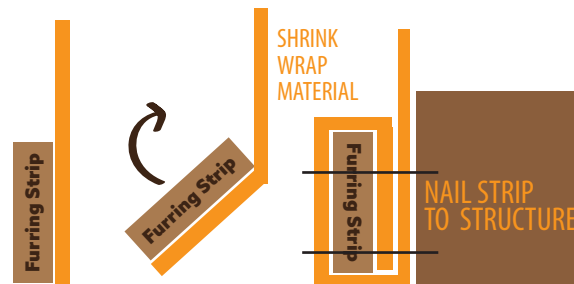

#### RECOMMENDED HEAT TOOLS



DS-SHFAST998



DS-RPK3000

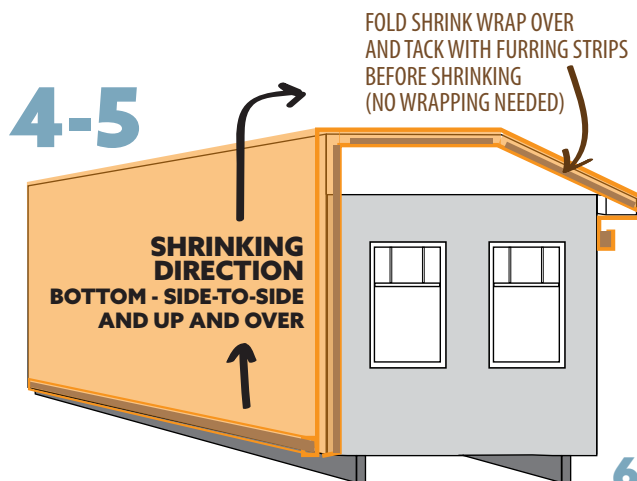

ONCE EDGE FURRING STRIPS AND END SIDE FURRING STRIPS ARE SECURELY HOLDING THE SHRINK WRAP IN PLACE, THE ENTIRE COVER CAN BE SHRUNK





# SCAFFOLDING SHRINK WRAPPING

The following are some of the most frequently asked questions when encapsulating and shrink wrapping scaffolding. Here we highlight how to properly measure for your roll width while also providing tips for fastening and securing to your sub structure.

## HOW TO INSTALL SHRINK WRAP OVER SCAFFOLDING

1. Make sure your scaffolding has top and bottom horizontal anchor points. If no poles are available, we recommend attaching steel cable. Tighten securely between each of the uprights the length of your desired shrink wrapping length. **We recommend using our 12-mil white shrink wrap** for all scaffolding projects. Flame retardant is also available.
2. Begin unfolding the shrink wrap and lapping it over the top support cable. Heat weld the shrink wrap around the cable every 5-6 feet as it is being unfolded to temporarily hold it in place. *Note: during the heat weld process, you are bringing the shrink wrap around the cable or scaffold pole and welding the material back to itself. A minimum heat weld of 12 inches is recommended.*
3. Once the material is unfolded and spot welded around the top, finish the top heat weld and perform the same operation on the bottom and sides.
4. When all four sides are secured, you are ready to start the shrinking process. Start at the bottom and work up using one continuous motion. After shrinking the entire cover, perform a visual inspection. Seal all holes, tears, and heat welds with our 4" Heat Shrink Tape.
5. Install our  $\frac{3}{4}$ " nylon banding over the exterior of the shrink wrap in an "X" fashion by tying around the scaffold poles and using our buckle and tension tool system to ensure the band is extremely tight. The goal here is to prevent the wind from blowing the shrink wrap out away from the scaffolding. **Note: for jobs requiring more than one sheet of material, our shrink wrap is easily joined together by overlapping the sheets and heat welding them using one of our premium heat tools.**

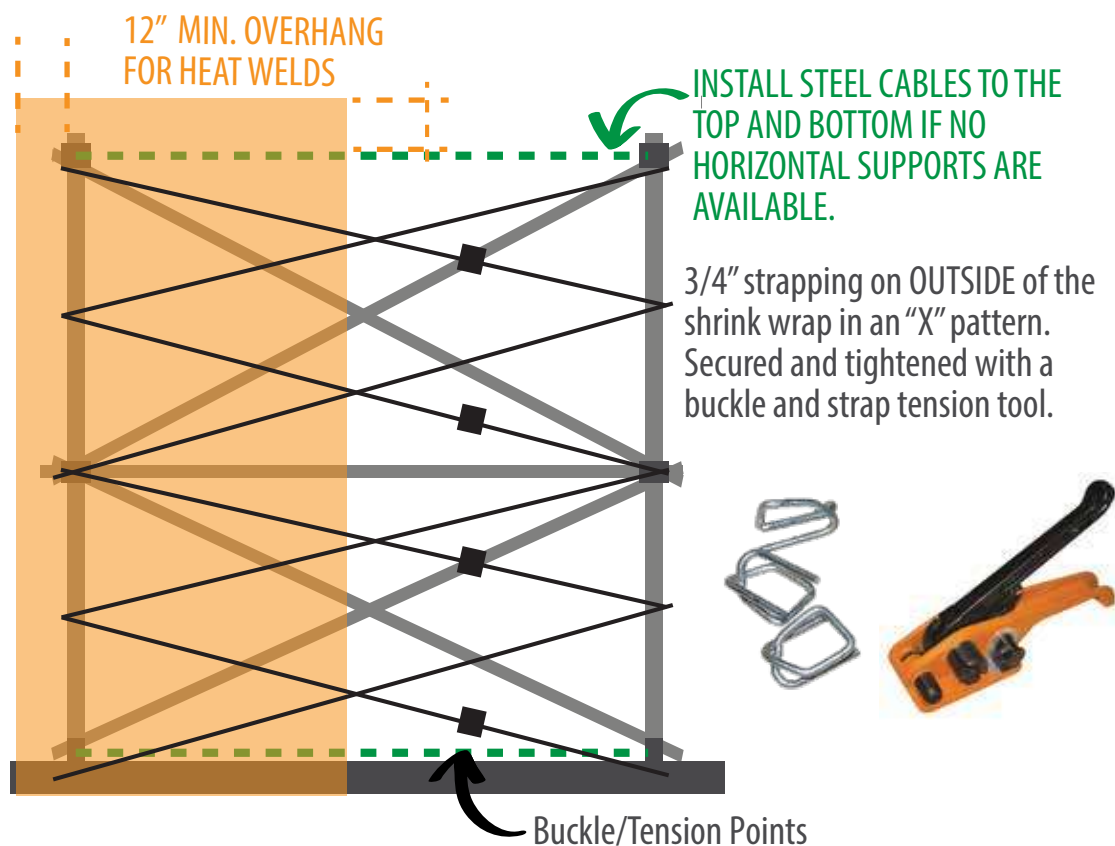

# FILM SIZES & VENTING



All shrink wrap covers must be ventilated to eliminate moisture, condensation, and mildew during the winter storage season. The number of vents needed to give a boat cross-flow ventilation will depend on the size and shape of the vessel. Remember – it is better to over ventilate the cover with additional vents rather than not installing enough. The following is an idea of the number needed by boat size:

Boat Size	# of Vents	Location
0'-18'	3	Two vents behind windshield and one at rear of cockpit.
19'-24'	4	Two vents in rear of cockpit and two forward of windshield.
25'-32'	6	Two vents in rear of cockpit, two at midsection, and two near bow.
33'-42'	8	Two vents in rear of cockpit, two on fly bridge, two amidship, and two near bow.
43' & Above	8-12	Same as above, with extras along the sides of the craft.

## DS-683 "WEATHER-TIGHT" VENT INSTALLATION PROCEDURES:



1

Completely shrink the cover before installing vents.



2

Vents may be installed on a horizontal or vertical surface. In areas receiving significant snow loads, vertical orientation is best as the vent will be less susceptible to snow cover-up.

3

Clean the cover if it is damp or dirty. Push against the cover to assure there is nothing behind the section you wish to install the vent which could impede air flow or be damaged by cutting (such as a seat cushion).



4

Remove the vent cover by squeezing the ends and remove the paper covering the adhesive backing on the base of the vent.

5

Affix the vent base to desired location and press firmly.



6

Carefully cut out the shrink wrap on the inside edge of the base. Reach inside and compress the shrink wrap against the adhesive base to insure proper adhesion.

7

Reinstall vent cover.

Film Size	Sq. Ft	Boat Length	Beam	# of Boats	# of Vents	Description
12' x 175'	2100	0'-16'	up to 7'	8	4	Works well for finishing boats & boats with low windshields
14' x 150'	2100	14'-19'	up to 8'	6	4	Great for runabout with full windshields
17' x 120'	2040	17'-24'	up to 8.5'	4	6	Excellent for pontoon boats and cuddy cabin cruisers
20' x 100'	2000	25'-29'	up to 8.5'	3	6	Good for express cruisers
24' x 115'	2760	25'-29'	up to 9'	3	6	Superb for express cruisers with arches or small flybridges
26' x 100'	2600	28'-31'	up to 10'	2	8	Very little waste on wider, taller flybridge boats under 32'
32' x 100'	3200	30'-38'	up to 11'	2	10	Super for wide and tall flybridge boats with an arch
40' x 100'	4000	44'-60'	up to 16'	1	12	Covers very large boats with arches and bridges with one piece of wrap
50' x 100'	5000	60'+	16'+	1	16	Excellent one piece coverage for the largest of boats with multiple levels, arches & bridges

# USING THE STRAPPING & BUCKLES

Dr.+



The following is a brief visual explanation of how to use the buckles and strapping system.



**1** Loop the strapping and prepare the buckle



**2** Put the looped strapping through the center opening of the buckle



**3** Separate loop thread over the open end of the buckle



**4** Pull top strap to secure to the buckle



**5** Repeat on other side of the buckle