

**INSTRUCTION MANUAL**

---

**DEWALT®**

---

**DWP849, DWP849X**

**Polishers**

**Polisseuses**

**Pulidoras**

## Definitions: Safety Guidelines

The definitions below describe the level of severity for each signal word. Please read the manual and pay attention to these symbols.

**⚠ DANGER:** Indicates an imminently hazardous situation which, if not avoided, **will** result in **death or serious injury**.

**⚠ WARNING:** Indicates a potentially hazardous situation which, if not avoided, **could** result in **death or serious injury**.

**⚠ CAUTION:** Indicates a potentially hazardous situation which, if not avoided, **may** result in **minor or moderate injury**.

**NOTICE:** Indicates a practice **not related to personal injury** which, if not avoided, **may** result in **property damage**.



**WARNING:** To reduce the risk of injury, read the instruction manual.

## General Power Tool Safety Warnings



**WARNING!** Read all safety warnings and all instructions. Failure to follow the warnings and instructions may result in electric shock, fire and/or serious injury.

## SAVE ALL WARNINGS AND INSTRUCTIONS FOR FUTURE REFERENCE

The term “power tool” in the warnings refers to your mains-operated (corded) power tool or battery-operated (cordless) power tool.

### 1) WORK AREA SAFETY

- a) **Keep work area clean and well lit.** Cluttered or dark areas invite accidents.
- b) **Do not operate power tools in explosive atmospheres, such as in the presence of flammable liquids, gases or dust.** Power tools create sparks which may ignite the dust or fumes.
- c) **Keep children and bystanders away while operating a power tool.** Distractions can cause you to lose control.

### 2) ELECTRICAL SAFETY

- a) **Power tool plugs must match the outlet. Never modify the plug in any way. Do not use any adapter plugs with earthed (grounded) power tools.** Unmodified plugs and matching outlets will reduce risk of electric shock.
- b) **Avoid body contact with earthed or grounded surfaces such as pipes, radiators, ranges and refrigerators.** There is an increased risk of electric shock if your body is earthed or grounded.
- c) **Do not expose power tools to rain or wet conditions.** Water entering a power tool will increase the risk of electric shock.
- d) **Do not abuse the cord. Never use the cord for carrying, pulling or unplugging the power tool. Keep cord away from heat, oil, sharp edges or moving parts.** Damaged or entangled cords increase the risk of electric shock.
- e) **When operating a power tool outdoors, use an extension cord suitable for outdoor use.** Use of a cord suitable for outdoor use reduces the risk of electric shock.
- f) **If operating a power tool in a damp location is unavoidable, use a ground fault circuit interrupter (GFCI) protected supply.** Use of a GFCI reduces the risk of electric shock.

### 3) PERSONAL SAFETY

- a) **Stay alert, watch what you are doing and use common sense when operating a power tool. Do not use a power tool while you are tired or under the influence of drugs, alcohol or medication.** A moment of inattention while operating power tools may result in serious personal injury.
  - b) **Use personal protective equipment. Always wear eye protection.** Protective equipment such as dust mask, non-skid safety shoes, hard hat, or hearing protection used for appropriate conditions will reduce personal injuries.
  - c) **Prevent unintentional starting. Ensure the switch is in the off position before connecting to power source and/or battery pack, picking up or carrying the tool.** Carrying power tools with your finger on the switch or energizing power tools that have the switch on invites accidents.
  - d) **Remove any adjusting key or wrench before turning the power tool on.** A wrench or a key left attached to a rotating part of the power tool may result in personal injury.
  - e) **Do not overreach. Keep proper footing and balance at all times.** This enables better control of the power tool in unexpected situations.
  - f) **Dress properly. Do not wear loose clothing or jewelry. Keep your hair, clothing and gloves away from moving parts.** Loose clothes, jewelry or long hair can be caught in moving parts.
  - g) **If devices are provided for the connection of dust extraction and collection facilities, ensure these are connected and properly used.** Use of dust collection can reduce dust-related hazards.
- b) **Do not use the power tool if the switch does not turn it on and off.** Any power tool that cannot be controlled with the switch is dangerous and must be repaired.
  - c) **Disconnect the plug from the power source and/or the battery pack from the power tool before making any adjustments, changing accessories, or storing power tools.** Such preventive safety measures reduce the risk of starting the power tool accidentally.
  - d) **Store idle power tools out of the reach of children and do not allow persons unfamiliar with the power tool or these instructions to operate the power tool.** Power tools are dangerous in the hands of untrained users.
  - e) **Maintain power tools. Check for misalignment or binding of moving parts, breakage of parts and any other condition that may affect the power tool's operation. If damaged, have the power tool repaired before use.** Many accidents are caused by poorly maintained power tools.
  - f) **Keep cutting tools sharp and clean.** Properly maintained cutting tools with sharp cutting edges are less likely to bind and are easier to control.
  - g) **Use the power tool, accessories and tool bits etc., in accordance with these instructions taking into account the working conditions and the work to be performed.** Use of the power tool for operations different from those intended could result in a hazardous situation.

### 5) SERVICE

- a) **Have your power tool serviced by a qualified repair person using only identical replacement parts.** This will ensure that the safety of the power tool is maintained.

### 4) POWER TOOL USE AND CARE

- a) **Do not force the power tool. Use the correct power tool for your application.** The correct power tool will do the job better and safer at the rate for which it was designed.

## Safety Instructions for All Operations

- a) **This power tool is intended to function as a polisher. Read all safety warnings, instructions, illustrations and specifications provided with this power tool. Failure to follow all instructions listed below may result in electric shock, fire and/or serious injury.**
- b) **Operations such as grinding, sanding, wire brushing or cutting-off are not recommended to be performed with this power tool. Operations for which the power tool was not designed may create a hazard and cause personal injury.**
- c) **Do not use accessories which are not specifically designed and recommended by the tool manufacturer. Just because the accessory can be attached to your power tool, it does not assure safe operation.**
- d) **The rated speed of the accessory must be at least equal to the maximum speed marked on the power tool. Accessories running faster than their rated speed can break and fly apart.**
- e) **The outside diameter and the thickness of your accessory must be within the capacity rating of your power tool. Incorrectly sized accessories cannot be adequately guarded or controlled.**
- f) **Threaded mounting of accessories must match the grinder spindle thread. For accessories mounted by flanges, the arbour hole of the accessory must fit the locating diameter of the flange. Accessories that do not match the mounting hardware of the power tool will run out of balance, vibrate excessively and may cause loss of control.**
- g) **Do not use a damaged accessory. Before each use inspect the accessory such as abrasive wheels for chips and cracks, backing pad for cracks, tear or excess wear, wire brush for loose or cracked wires. If power tool or accessory is dropped, inspect for damage or install an undamaged accessory. After inspecting and installing an accessory, position yourself and bystanders away from the plane of the rotating accessory and run the power tool at maximum no-load speed for one minute. Damaged accessories will normally break apart during this test time.**
- h) **Wear personal protective equipment. Depending on application, use face shield, safety goggles or safety glasses. As appropriate, wear dust mask, hearing protectors, gloves and workshop apron capable of stopping small abrasive or workpiece fragments. The eye protection must be capable of stopping flying debris generated by various operations. The dust mask or respirator must be capable of filtering particles generated by your operation. Prolonged exposure to high intensity noise may cause hearing loss.**
- i) **Keep bystanders a safe distance away from work area. Anyone entering the work area must wear personal protective equipment. Fragments of workpiece or of a broken accessory may fly away and cause injury beyond immediate area of operation.**
- j) **Hold power tool by insulated gripping surfaces only, when performing an operation where the cutting accessory may contact hidden wiring or its own cord. Cutting accessory contacting a "live" wire may make exposed metal parts of the power tool "live" and shock the operator.**
- k) **Position the cord clear of the spinning accessory. If you lose control, the cord may be cut or snagged and your hand or arm may be pulled into the spinning accessory.**
- l) **Never lay the power tool down until the accessory has come to a complete stop. The spinning accessory may grab the surface and pull the power tool out of your control.**

- m) **Do not run the power tool while carrying it at your side.** Accidental contact with the spinning accessory could snag your clothing, pulling the accessory into your body.
- n) **Regularly clean the power tool's air vents.** The motor's fan will draw the dust inside the housing and excessive accumulation of powdered metal may cause electrical hazards.
- o) **Do not operate the power tool near flammable materials.** Sparks could ignite these materials.
- p) **Do not use accessories that require liquid coolants.** Using water or other liquid coolants may result in electrocution or shock.

## Further Safety Instructions for All Operations

### KICKBACK AND RELATED WARNINGS

Kickback is a sudden reaction to a pinched or snagged rotating wheel, backing pad, brush or any other accessory. Pinching or snagging causes rapid stalling of the rotating accessory which in turn causes the uncontrolled power tool to be forced in the direction opposite of the accessory's rotation at the point of the binding.

For example, if an abrasive wheel is snagged or pinched by the workpiece, the edge of the wheel that is entering into the pinch point can dig into the surface of the material causing the wheel to climb out or kick out. The wheel may either jump toward or away from the operator, depending on direction of the wheel's movement at the point of pinching. Abrasive wheels may also break under these conditions.

Kickback is the result of tool misuse and/or incorrect operating procedures or conditions and can be avoided by taking proper precautions as given below:

- a) **Maintain a firm grip on the power tool and position your body and arm to allow you to resist kickback forces. Always use auxiliary handle, if provided, for maximum control over kickback or torque reaction during start up.** The operator can control torque reaction or kickback forces, if proper precautions are taken.
- b) **Never place your hand near the rotating accessory.** Accessory may kickback over your hand.
- c) **Do not position your body in the area where power tool will move if kickback occurs.** Kickback will propel the tool in direction opposite to the wheel's movement at the point of snagging.
- d) **Use special care when working corners, sharp edges, etc. Avoid bouncing and snagging the accessory.** Corners, sharp edges or bouncing have a tendency to snag the rotating accessory and cause loss of control or kickback.
- e) **Do not attach a saw chain woodcarving blade or toothed saw blade.** Such blades create frequent kickback and loss of control.

## Safety Warnings Specific for Polishing Operations

- a) **Do not allow any loose portion of the polishing bonnet or its attachment strings to spin freely. Tuck away or trim any loose attachment strings.** Loose and spinning attachment strings can entangle your fingers or snag on the workpiece.

## Additional Specific Safety Instructions for Polishers

- **Always use eye protection.** All users and bystanders must wear eye protection that conforms to ANSI Z87.1.

- **Clean out your tool often, especially after heavy use.** Dust and grit containing metal particles often accumulate on interior surfaces and could create an electric shock hazard.
- **Do not operate this tool for long periods of time.** Vibration caused by the operating action of this tool may cause permanent injury to fingers, hands and arms. Use gloves to provide extra cushion, take frequent rest periods and limit daily time of use.
- **Air vents often cover moving parts and should be avoided.** Loose clothes, jewelry or long hair can be caught in moving parts.
- **An extension cord must have adequate wire size (AWG or American Wire Gauge) for safety.** The smaller the gauge number of the wire, the greater the capacity of the cable, that is 16 gauge has more capacity than 18 gauge. An undersized cord will cause a drop in line voltage resulting in loss of power and overheating. When using more than one extension to make up the total length, be sure each individual extension contains at least the minimum wire size. The following table shows the correct size to use depending on cord length and nameplate ampere rating. If in doubt, use the next heavier gauge. The smaller the gauge number, the heavier the cord.

Minimum Gauge for Cord Sets						
Ampere Rating		Volts	Total Length of Cord in Feet (meters)			
		120V	25 (7.6)	50 (15.2)	100 (30.5)	150 (45.7)
		240V	50 (15.2)	100 (30.5)	200 (61.0)	300 (91.4)
More Than	Not More Than	AWG				
0	6		18	16	16	14
6	10		18	16	14	12
10	12		16	16	14	12
12	16		14	12	Not Recommended	

**⚠ WARNING: ALWAYS** use safety glasses. Everyday eyeglasses are NOT safety glasses. Also use face or dust mask if cutting operation is dusty. ALWAYS WEAR CERTIFIED SAFETY EQUIPMENT:

- ANSI Z87.1 eye protection (CAN/CSA Z94.3),
- ANSI S12.6 (S3.19) hearing protection,
- NIOSH/OSHA/MSHA respiratory protection.

**⚠ WARNING: Always wear proper personal hearing protection that conforms to ANSI S12.6 (S3.19) during use.** Under some conditions and duration of use, noise from this product may contribute to hearing loss.

**⚠ WARNING:** Some dust created by power sanding, sawing, grinding, drilling, and other construction activities contains chemicals known to the State of California to cause cancer, birth defects or other reproductive harm. Some examples of these chemicals are:

- lead from lead-based paints,
- crystalline silica from bricks and cement and other masonry products, and
- arsenic and chromium from chemically-treated lumber.

Your risk from these exposures varies, depending on how often you do this type of work. To reduce your exposure to these chemicals: work in a well ventilated area, and work with approved safety equipment, such as those dust masks that are specially designed to filter out microscopic particles.

- **Avoid prolonged contact with dust from power sanding, sawing, grinding, drilling and other construction activities. Wear protective clothing and wash exposed areas with soap and water.** Allowing dust to get into your mouth, eyes, or lay on the skin may promote absorption of harmful chemicals.

**⚠ WARNING:** Use of this tool can generate and/or disperse dust, which may cause serious and permanent respiratory or other injury. Always use NIOSH/OSHA approved respiratory protection appropriate for the dust exposure. Direct particles away from face and body.

**⚠ CAUTION:** Use extra care when working into a corner because a sudden, sharp movement of the polisher may be experienced when the wheel or other accessory contacts a secondary surface or a surface edge.

- The label on your tool may include the following symbols. The symbols and their definitions are as follows:

V.....volts	A.....amperes
Hz.....hertz	W.....watts
min .....minutes	~ or AC.....alternating current
== or DC...direct current	⎓ or AC/DC...alternating or direct current
⚠.....Class I Construction (grounded)	⎓.....no load speed
□.....Class II Construction (double insulated)	n .....rated speed
.../min .....per minute	⊕.....earthing terminal
BPM.....beats per minute	⚠.....safety alert symbol
IPM.....impacts per minute	
RPM.....revolutions per minute	
sfpm .....surface feet per minute	
SPM .....strokes per minute	

## SAVE THESE INSTRUCTIONS

### Motor

Be sure your power supply agrees with the nameplate marking. Voltage decrease of more than 10% will cause loss of power and overheating. DEWALT tools are factory tested; if this tool does not operate, check power supply.

### COMPONENTS (Fig. 1)

**⚠ WARNING:** Never modify the power tool or any part of it. Damage or personal injury could result.

- |                                    |                                |
|------------------------------------|--------------------------------|
| A. Speed control wheel             | G. Trigger locking button      |
| B. Cushion tool rest (DWP849 only) | H. Bale handle                 |
| C. Variable speed trigger switch   | I. Spindle                     |
| D. Brush inspection cap            | J. Soft rubber gear case cover |
| E. Spindle lock button             | K. Wool ingestion shield       |
| F. Auxiliary handle                |                                |

### INTENDED USE

The DWP849 and DWP849X heavy-duty polishers are designed for polishing painted or unfinished metal, fiberglass, and composite surfaces in professional applications. Common examples of use include but are not limited to: auto/marine/RV/motorcycle detailing and finish correction, boat construction and repair, and metal or concrete finishing.

Do not use in the presence of flammable liquids or gases. Do not let children come into contact with the tool. Supervision is required when inexperienced operators use this tool.

FIG. 1

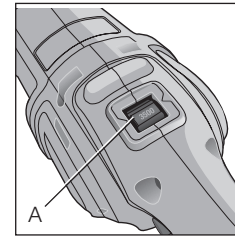
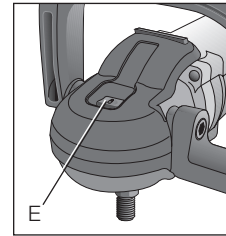
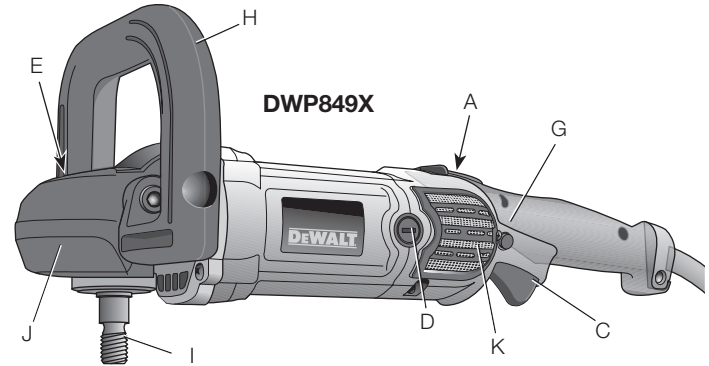
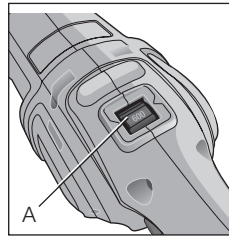
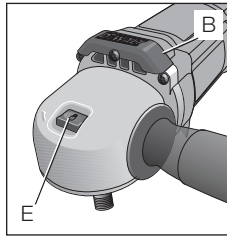
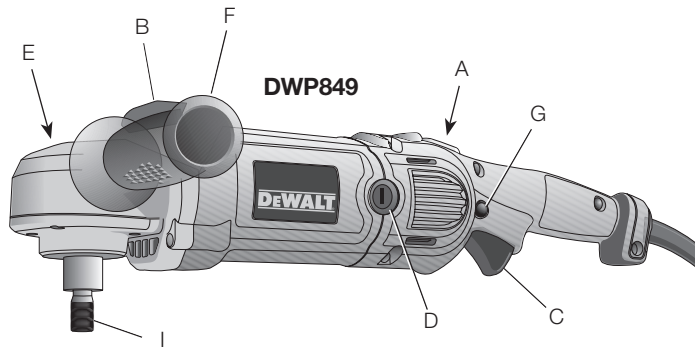

### **Auxiliary Handle (Fig. 1)**

An auxiliary handle (F) is furnished with your tool and can be installed on either side of the gear case. This handle should be used at all times to maintain complete control of the tool.

A bale handle (H) is also provided with the DWP849X and can be used in place of the auxiliary handle.

### **Variable Speed Trigger Switch (Fig. 1)**

These tools are equipped with a variable speed trigger switch that permits speed control from 0 to 3500 RPM. To turn the tool on, squeeze the trigger switch (C) shown in Figure 1 until the tool starts to run. The farther you depress the trigger, the faster it will operate. Releasing the trigger turns the tool off.



Use lower speeds for applying liquid waxes and polishes and higher speeds for removing dried liquid. Use the highest speed (fully depress trigger) for buffing the car to a final lustre.

The tool can be locked on for continuous use by squeezing the trigger switch fully and depressing the lock button (G) shown in Figure 1. Hold the lock button in as you gently release the trigger switch. The tool will continue to run. To turn the tool off from a locked-on position, squeeze and release the trigger switch once. Do not unplug the tool with the switch in the locked-on condition. Make sure the tool is not locked on when plugging in.

The variable speed trigger switch (C) has a no-volt release function. In the event of a power outage or other unexpected shut down, the trigger switch needs to be cycled (depress the trigger switch, release, then depress again) to restart the tool. Do not unplug the tool with the trigger switch in the locked-on condition. Make sure the tool is not locked on when plugging in. If the tool is plugged back in with the trigger switch in the locked-on position, the tool will not run until the trigger switch (C) is cycled as described above.

**NOTE:** The trigger switch can only be locked on with the tool running at the maximum RPM designated by the speed control wheel (A).

### **Speed Control Wheel (Fig. 1)**

The maximum speed of your tool can be changed by rotating the speed control wheel (A) to the desired setting. The wheel incorporates detents to prevent inadvertent wheel movement and to facilitate speed selection. For added versatility, the trigger switch may be locked in its full on position and tool speed changed by means of the speed control wheel (A) alone.

The electronic speed control not only lets you select the speed to suit the job, but also helps to maintain that speed as you load the tool by pressing down. It's this feature, coupled with the variable speed trigger switch, that make this tool such a value.

The speed control wheel (A) can be set for any speed between 600 and 3500 RPM and the variable speed switch will then control tool speed from zero to the wheel setting. For example: A control wheel setting of 2200 RPM will allow the variable speed switch to operate the tool between zero and 2200 RPM, depending on how far the trigger switch is depressed. A wheel setting of 600 RPM would allow the switch to operate the tool from zero to 600 RPM.

The electronic speed control feature comes into play whenever the trigger switch is fully depressed and the tool is running at the selected speed determined by the setting of the control wheel. As you load the tool by pushing it down on the work surface, (with the trigger fully depressed) the electronic circuit inside the tool will compensate for the loading and maintain the selected speed. If the speed selected by the control wheel is 2200 RPM, as in the example above, the tool will maintain 2200 RPM, as it is loaded.

It is important to remember two things about electronic speed control:

1. The electronic speed control operates only when the trigger switch (C) is fully depressed.
2. The effect of electronic speed control is much easier to observe at lower speed settings (2600 RPM and below), than at high speeds. As the tool approaches 3000 RPM, the effect is considerably less dramatic.

Keep in mind that, with a conventional polisher running at a typical no-load speed of 2400 RPM, the tool slows down to about 2000 RPM under a polishing load. Your DWP849 or DWP849X will continue to run at 2400 RPM (or any speed you select with the control wheel) as a load is applied. Since it doesn't slow down, the speed may be greater than you're used to, so some extra caution should be observed until you get the "feel" of your polisher. If you feel the speed is too great, you can, of course, slow the tool down with either the trigger switch or the control wheel.

## Spindle Lock Button (Fig. 1)

**⚠ WARNING:** To reduce the risk of serious personal injury, turn tool off and disconnect tool from power source before making any adjustments or removing/installing attachments or accessories. Before reconnecting the tool, depress and release the trigger switch to ensure that the tool is off.

In order to prevent the spindle of the tool from rotating while installing or removing accessories, a spindle lock button (E) has been provided in the gear head of the machine. To lock the spindle, depress and hold the lock button. NEVER DEPRESS THE SPINDLE LOCK BUTTON WITH THE TOOL RUNNING OR COASTING.

## Wool Ingestion Shields (Fig. 1, 2)

The wool ingestion shields (K) are designed to reduce the amount of wool, dust, and debris that gets ingested by the motor during normal use. The goal of the ingestion shields is to improve durability as compared to a unit without the ingestion shields.

Each ingestion shield can be easily removed for cleaning by removing the mounting screw (L), followed by sliding the shield back towards the trigger end of the tool and then lifting it off.

The wool ingestion shields can be cleaned with soap and water and a soft bristle brush in the event they get clogged with polish and debris. Clean the shields as soon as you start to see buildup on the outside. Your tool may come with a set of wool ingestion shields. The wool ingestion shields are available at extra cost from your local dealer or authorized service center.

FIG. 2

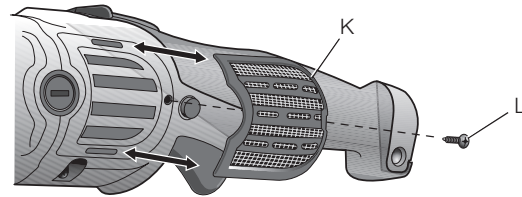

## Soft Rubber Gear Case Cover (Fig. 1)

The soft rubber gear case cover (J) is designed to eliminate metal gear case scuffs on painted or polished surfaces.

The soft rubber gear case cover can be removed if required. To take off the cover, remove the three mounting screws and lift the cover over the gear case.

Your tool may come with a soft rubber gear case cover. The soft rubber gear case cover is available at extra cost from your local dealer or authorized service center.

## OPERATION

**⚠ WARNING:** To reduce the risk of serious personal injury, turn tool off and disconnect tool from power source before making any adjustments or removing/installing attachments or accessories. Before reconnecting the tool, depress and release the trigger switch to ensure that the tool is off.

Polishing pads with a diameter of 6", 7" or 9" (15.2, 17.8 or 22.9 cm) may be used with the DWP849 and DWP849X.

## Attaching and Removing Polishing Pads (Fig. 3)

**⚠ WARNING:** To reduce the risk of serious personal injury, do not allow any loose portion of the polishing bonnet or its attachment strings to spin freely. Tuck away or trim any loose attachment strings. Loose and spinning attachment strings can entangle your fingers or snag on the workpiece.

**NOTE:** Both the DWP849 and the DWP849X may use either type of polishing pad assembly described below.

### TO ATTACH POLISHING PAD WITH RUBBER BACKING PAD (FIG. 3A)

1. To attach polishing pad (N), push the hub of the clamp washer (M) through the hole in the center of the polishing pad as far as it will go.
2. Engage the hexagonal hole in the backing pad (O). Holding the three pieces firmly together, place the assembly on the tool spindle (I).
3. Hold the spindle lock button (E) while turning the pads clockwise to thread them completely on the spindle.

FIG. 3A

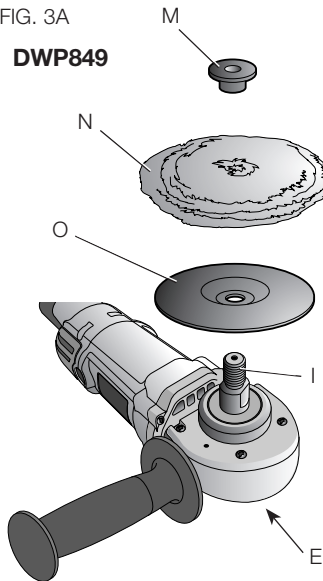

### TO ATTACH POLISHING PAD WITH HOOK AND LOOP BACKING PAD (FIG. 3B)

1. Attach hook and loop foam or wool pad (P) to hook and loop backing pad (Q), being careful to center the backing pad with the foam or wool pad.
2. Screw backing pad (Q) onto spindle (I), while depressing spindle lock button (E).

FIG. 3B

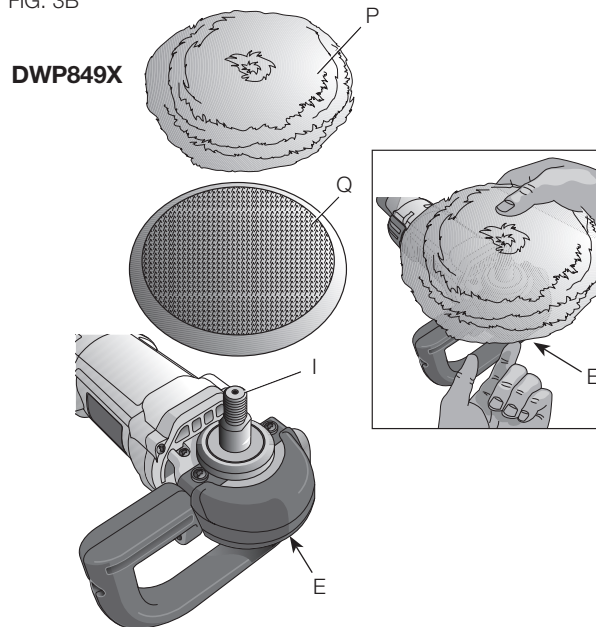

## TO REMOVE PADS

Turn them by hand in the opposite direction from normal rotation to allow lock button to engage spindle, then unscrew pads in normal direction for right-hand thread.

## Polishing (Fig. 4)

These instructions and suggestions are intended to familiarize new operators in overall general operation of power polishing. You will develop your own techniques which will make the job easier and faster as you learn power polishing.

FIG. 4

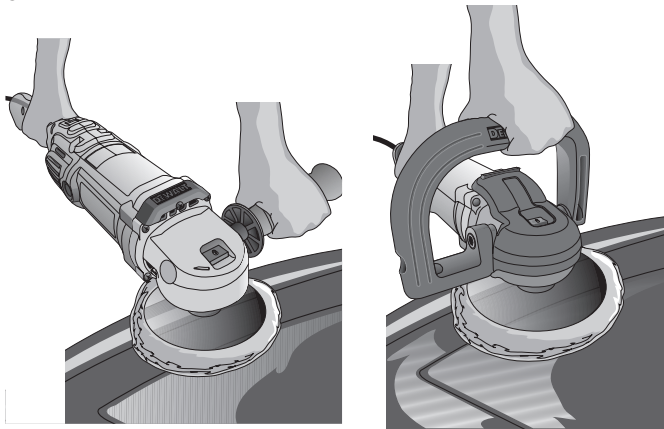

- You should use utmost care when power polishing around or over sharp objects and contours of the car body. It is very important to use the correct pressure while polishing various sections of an automobile body. For example, light pressure should be applied when polishing over sharp edges of body panels, or over edges of the rain gutter along the top.

- Since everyone does not use the same type of power polish, we recommend you clean and polish a test section on a flat area of the car first. From this test section, you can judge the strength or cleaning action of your power polish.
- Remember, all power polish is not the same. Different brands will react differently on various painted surfaces. Also, you are now using a power polisher with power polish. This is entirely different from any hand application which you may have done before. Wash the car before power polishing it. Washing will remove loose dirt, scum, road salt, etc. which could act as an abrasive and damage paint. Loose dirt, etc. will also clog the polishing pad and you will have to clean it more often.
- Without turning the tool on, grasp the handles of the tool and pick it up (Fig. 4). Keep the tool away from your body and depress the trigger switch. Make sure you have a firm grip on the handles and operate the tool freely without forced effort or unnecessary pressure. The side handle can be easily changed to either side of the tool for left-handed or right-handed operation.

**NOTE:** The high speed rubbing action of the polishing bonnet upon the surface of an automobile can build a static charge on the metal portions of this tool. This can result in a sensation of a very short mild electric shock when the metal area of the tool is touched, and will be more noticeable on days when the humidity is low. This is a harmless phenomenon but you are invited to bring the tool to a DEWALT service center where it can be checked to assure that no electrical malfunction is present.

## MAINTENANCE

Your DEWALT power tool has been designed to operate over a long period of time with a minimum of maintenance. Continuous satisfactory operation depends upon proper tool care and regular cleaning.

**⚠ WARNING:** To reduce the risk of serious personal injury, turn tool off and disconnect tool from power source before

**making any adjustments or removing/installing attachments or accessories. Before reconnecting the tool, depress and release the trigger switch to ensure that the tool is off.**

## Cleaning

**⚠ WARNING:** Blow dirt and dust out of all air vents with dry air at least once a week. Wear proper ANSI Z87.1 (CAN/CSA Z94.3) eye protection and proper NIOSH/OSHA/MSHA respiratory protection when performing this.

**⚠ WARNING:** Never use solvents or other harsh chemicals for cleaning the non-metallic parts of the tool. These chemicals may weaken the plastic materials used in these parts. Use a cloth dampened only with water and mild soap. Never let any liquid get inside the tool; never immerse any part of the tool into a liquid.

## Lubrication

DEWALT tools are properly lubricated at the factory and are ready for use. Tools should be relubricated regularly every sixty days to six months, depending on usage. (Tools used constantly on production or heavy-duty jobs and tools exposed to heat may require more frequent lubrication.) This lubrication should only be attempted by trained power tool repairpersons such as those at DEWALT service centers or other authorized service locations.

## Motor Brushes

Be sure tool is unplugged before inspecting brushes. Carbon brushes should be regularly inspected for wear. To inspect brushes, unscrew the plastic brush inspection caps (located in the sides of the motor housing) so the spring and brush assemblies may be withdrawn from the tool. Keep brushes clean and sliding freely in their guides. Carbon brushes have varying symbols stamped into them, and if the brushes are worn down to the line closest to the spring, they must be replaced.

## Accessories

**⚠ WARNING:** Since accessories, other than those offered by DEWALT, have not been tested with this product, use of such accessories with this tool could be hazardous. To reduce the risk of injury, only DEWALT recommended accessories should be used with this product.

Recommended accessories for use with your tool are available at extra cost from your local dealer or authorized service center.

Use only accessories having a maximum operating speed at least as high as the highest "NO LOAD RPM" marked on the tool's nameplate. This precaution applies to any accessory on any tool.

- 1-**Rubber backing pads:** 7" (17.8 cm) Quick Change Super Flexible Rubber Backing Pad (includes clamp washer)
- 2-**7" (17.8 cm) hook and loop backing pads**
- 3-**Soft rubber gear case cover**
- 4-**Wool ingestion shields**
- 5-**Auxiliary handle**
- 6-**Bale handle**

## Repairs

To assure product SAFETY and RELIABILITY, repairs, maintenance and adjustments (including brush inspection and replacement) should be performed by a DEWALT factory service center, a DEWALT authorized service center or other qualified service personnel. Always use identical replacement parts.