



**DCS331  
20V Max\* Cordless Jig Saw**

**Definitions: Safety Guidelines**

The definitions below describe the level of severity for each signal word. Please read the manual and pay attention to these symbols.

**⚠ DANGER:** Indicates an imminently hazardous situation which, if not avoided, **will result in death or serious injury.**

**⚠ WARNING:** Indicates a potentially hazardous situation which, if not avoided, **could result in death or serious injury.**

**⚠ CAUTION:** Indicates a potentially hazardous situation which, if not avoided, **may result in minor or moderate injury.**

**NOTICE:** Indicates a practice **not related to personal injury** which, if not avoided, **may result in property damage.**

**WARNING:** To reduce the risk of injury, read the instruction manual.

**General Power Tool Safety Warnings**

**⚠ WARNING!** Read all safety warnings and all instructions. Failure to follow the warnings and instructions may result in electric shock, fire and/or serious injury.

**SAVE ALL WARNINGS AND INSTRUCTIONS FOR FUTURE REFERENCE**

The term “power tool” in the warnings refers to your mains-operated (corded) power tool or battery-operated (cordless) power tool.

**1) WORK AREA SAFETY**

- Keep work area clean and well lit. Cluttered or dark areas invite accidents.
- Do not operate power tools in explosive atmospheres, such as in the presence of flammable liquids, gases or dust. Power tools create sparks which may ignite the dust or fumes.
- Keep children and bystanders away while operating a power tool. Distractions can cause you to lose control.

**2) ELECTRICAL SAFETY**

- Power tool plugs must match the outlet. Never modify the plug in any way. Do not use any adapter plugs with earthed (grounded) power tools. Unmodified plugs and matching outlets will reduce risk of electric shock.
- Avoid body contact with earthed or grounded surfaces such as pipes, radiators, ranges and refrigerators. There is an increased risk of electric shock if your body is earthed or grounded.
- Do not expose power tools to rain or wet conditions. Water entering a power tool will increase the risk of electric shock.
- Do not abuse the cord. Never use the cord for carrying, pulling or unplugging the power tool. Keep cord away from heat, oil, sharp edges or moving parts. Damaged or entangled cords increase the risk of electric shock.
- When operating a power tool outdoors, use an extension cord suitable for outdoor use. Use of a cord suitable for outdoor use reduces the risk of electric shock.
- If operating a power tool in a damp location is unavoidable, use a ground fault circuit interrupter (GFCI) protected supply. Use of a GFCI reduces the risk of electric shock.

**3) PERSONAL SAFETY**

- Stay alert, watch what you are doing and use common sense when operating a power tool. Do not use a power tool while you are tired or under the influence of drugs, alcohol or medication. A moment of inattention while operating power tools may result in serious personal injury.
- Use personal protective equipment. Always wear eye protection. Protective equipment such as dust mask, non-skid safety shoes, hard hat, or hearing protection used for appropriate conditions will reduce personal injuries.
- Prevent unintentional starting. Ensure the switch is in the off position before connecting to power source and/or battery pack, picking up or carrying the tool. Carrying power tools with your finger on the switch or energizing power tools that have the switch on invites accidents.
- Remove any adjusting key or wrench before turning the power tool on. A wrench or a key left attached to a rotating part of the power tool may result in personal injury.
- Do not overreach. Keep proper footing and balance at all times. This enables better control of the power tool in unexpected situations.
- Dress properly. Do not wear loose clothing or jewelry. Keep your hair, clothing and gloves away from moving parts. Loose clothes, jewelry or long hair can be caught in moving parts.
- If devices are provided for the connection of dust extraction and collection facilities, ensure these are connected and properly used. Use of dust collection can reduce dust-related hazards.

**4) POWER TOOL USE AND CARE**

- Do not force the power tool. Use the correct power tool for your application. The correct power tool will do the job better and safer at the rate for which it was designed.
- Do not use the power tool if the switch does not turn it on and off. Any power tool that cannot be controlled with the switch is dangerous and must be repaired.
- Disconnect the plug from the power source and/or the battery pack from the power tool before making any adjustments, changing accessories, or storing power tools. Such preventive safety measures reduce the risk of starting the power tool accidentally.
- Store idle power tools out of the reach of children and do not allow persons unfamiliar with the power tool or these instructions to operate the power tool. Power tools are dangerous in the hands of untrained users.
- Maintain power tools. Check for misalignment or binding of moving parts, breakage of parts and any other condition that may affect the power tool’s operation. If damaged, have the power tool repaired before use. Many accidents are caused by poorly maintained power tools.
- Keep cutting tools sharp and clean. Properly maintained cutting tools with sharp cutting edges are less likely to bind and are easier to control.
- Use the power tool, accessories and tool bits, etc. in accordance with these instructions, taking into account the working conditions and the work to be performed. Use of the power tool for operations different from those intended could result in a hazardous situation.

**5) BATTERY TOOL USE AND CARE**

- Recharge only with the charger specified by the manufacturer. A charger that is suitable for one type of battery pack may create a risk of fire when used with another battery pack.
- Use power tools only with specifically designated battery packs. Use of any other battery packs may create a risk of injury and fire.
- When battery pack is not in use, keep it away from other metal objects, like paper clips, coins, keys, nails, screws, or other small metal objects, that can make a connection from one terminal to another. Shorting the battery terminals together may cause burns or a fire.
- Under abusive conditions, liquid may be ejected from the battery; avoid contact. If contact accidentally occurs, flush with water. If liquid contacts eyes, additionally seek medical help. Liquid ejected from the battery may cause irritation or burns.

**6) SERVICE**

- Have your power tool serviced by a qualified repair person using only identical replacement parts. This will ensure that the safety of the power tool is maintained.

**Additional Specific Safety Rules for Jig Saws**

- Hold power tool by insulated gripping surfaces, when performing an operation where the cutting accessory may contact hidden wiring. Cutting accessory contacting a “live” wire may make exposed metal parts of the power tool “live” and could give the operator an electric shock.

- Use clamps or another practical way to secure and support the workpiece to a stable platform. Holding the work by hand or against your body leaves it unstable and may lead to loss of control.
- Allow the motor to come to a complete stop before withdrawing the blade from the kerf (the slot created by cutting). A moving blade may impact the workpiece causing a broken blade, workpiece damage or loss of control and possible personal injury.
- Keep handles dry, clean, free from oil and grease. This will enable better control of the tool.
- Keep blades sharp. Dull blades may cause the saw to swerve or stall under pressure.
- Clean out your tool often, especially after heavy use. Dust and grit containing metal particles often accumulate on interior surfaces and could create an electric shock hazard.
- Do not operate this tool for long periods of time. Vibration caused by the operating action of this tool may cause permanent injury to fingers, hands, and arms. Use gloves to provide extra cushion, take frequent rest periods, and limit daily time of use.
- Air vents often cover moving parts and should be avoided. Loose clothes, jewelry or long hair can be caught in moving parts.

**⚠ WARNING: ALWAYS** use safety glasses. Everyday eyeglasses are NOT safety glasses. Also use face or dust mask if cutting operation is dusty. ALWAYS WEAR CERTIFIED SAFETY EQUIPMENT:

- ANSI Z87.1 eye protection (CAN/CSA Z94.3),
- ANSI S12.6 (S3.19) hearing protection,
- NIOSH/OSHA/MSHA respiratory protection.

**⚠ WARNING:** Some dust created by power sanding, sawing, grinding, drilling, and other construction activities contains chemicals known to the State of California to cause cancer, birth defects or other reproductive harm. Some examples of these chemicals are:

- lead from lead-based paints,
- crystalline silica from bricks and cement and other masonry products, and
- arsenic and chromium from chemically-treated lumber.

Your risk from these exposures varies, depending on how often you do this type of work. To reduce your exposure to these chemicals: work in a well ventilated area, and work with approved safety equipment, such as those dust masks that are specially designed to filter out microscopic particles.

- Avoid prolonged contact with dust from power sanding, sawing, grinding, drilling, and other construction activities. Wear protective clothing and wash exposed areas with soap and water. Allowing dust to get into your mouth, eyes, or lay on the skin may promote absorption of harmful chemicals.

**⚠ WARNING:** Use of this tool can generate and/or disperse dust, which may cause serious and permanent respiratory or other injury. Always use NIOSH/OSHA approved respiratory protection appropriate for the dust exposure. Direct particles away from face and body.

**⚠ WARNING: Always wear proper personal hearing protection that conforms to ANSI S12.6 (S3.19) during use.** Under some conditions and duration of use, noise from this product may contribute to hearing loss.

**⚠ CAUTION: When not in use, place tool on its side on a stable surface where it will not cause a tripping or falling hazard.** Some tools with large battery packs will stand upright on the battery pack but may be easily knocked over.

- The label on your tool may include the following symbols. The symbols and their definitions are as follows:

V.....volts	A..... amperes
Hz.....hertz	W..... watts
min .....minutes	~ ..... alternating current
== ..... direct current	∞ ..... alternating or direct current
Ⓢ ..... Class I Construction (grounded)	no ..... no load speed
Ⓢ ..... Class II Construction (double insulated)	Ⓢ ..... earthing terminal
.../min .....per minute	▲..... safety alert symbol
IPM.....Impacts per minute	BPM.....beats per minute
	RPM..... revolutions per minute
	sfpm..... surface feet per minute

**Important Safety Instructions for All Battery Packs**

When ordering replacement battery packs, be sure to include the catalog number and voltage. Consult the chart at the end of this manual for compatibility of chargers and battery packs.

The battery pack is not fully charged out of the carton. Before using the battery pack and charger, read the safety instructions below and then follow charging procedures outlined.

**READ ALL INSTRUCTIONS**

- Do not charge or use the battery pack in explosive atmospheres, such as in the presence of flammable liquids, gases or dust. Inserting or removing the battery pack from the charger may ignite the dust or fumes.
- NEVER force the battery pack into the charger. DO NOT modify the battery pack in any way to fit into a non-compatible charger as battery pack may rupture causing serious personal injury. Consult the chart at the end of this manual for compatibility of batteries and chargers.
- Charge the battery packs only in designated DEWALT chargers.
- DO NOT splash or immerse in water or other liquids.
- Do not store or use the tool and battery pack in locations where the temperature may reach or exceed 105 °F (40 °C) (such as outside sheds or metal buildings in summer). For best life store battery packs in a cool, dry location.
- NOTE: Do not store the battery packs in a tool with the trigger switch locked on. Never tape the trigger switch in the ON position.

**⚠ WARNING:** Fire hazard. Never attempt to open the battery pack for any reason. If the battery pack case is cracked or damaged, do not insert into the charger. Do not crush, drop or damage the battery pack. Do not use a battery pack or charger that has received a sharp blow, been dropped, run over or damaged in any way (e.g., pierced with a nail, hit with a hammer, stepped on). Damaged battery packs should be returned to the service center for recycling.

**⚠ WARNING: Fire hazard. Do not store or carry the battery pack so that metal objects can contact exposed battery terminals.** For example, do not place the battery pack in aprons, pockets, tool boxes, product kit boxes, drawers, etc., with loose nails, screws, keys, etc. Transporting batteries can possibly cause fires if the battery terminals inadvertently come in contact with conductive materials such as keys, coins, hand tools and the like. The US Department of Transportation Hazardous Material Regulations (HMR) actually prohibit transporting batteries in commerce or on airplanes (e.g., packed in suitcases and carry-on luggage) UNLESS they are properly protected from short circuits. So when transporting individual battery packs, make sure that the battery terminals are protected and well insulated from materials that could contact them and cause a short circuit.

**SPECIFIC SAFETY INSTRUCTIONS FOR LITHIUM ION (Li-Ion)**

- Do not incinerate the battery pack even if it is severely damaged or is completely worn out. The battery pack can explode in a fire. Toxic fumes and materials are created when lithium ion battery packs are burned.
  - If battery contents come into contact with the skin, immediately wash area with mild soap and water. If battery liquid gets into the eye, rinse water over the open eye for 15 minutes or until irritation ceases. If medical attention is needed, the battery electrolyte is composed of a mixture of liquid organic carbonates and lithium salts.
  - Contents of opened battery cells may cause respiratory irritation. Provide fresh air. If symptoms persist, seek medical attention.
- ⚠ WARNING:** Burn hazard. Battery liquid may be flammable if exposed to spark or flame.

**The RBRC™ Seal**

The RBRC™ (Rechargeable Battery Recycling Corporation) Seal on the nickel cadmium, nickel metal hydride or lithium ion batteries (or battery packs) indicate that the costs to recycle these batteries (or battery packs) at the end of their useful life have already been paid by DEWALT. In some areas, it is illegal to place spent nickel cadmium, nickel metal hydride or lithium ion batteries in the trash or municipal solid waste stream and the RBRC program provides an environmentally conscious alternative.



RBRC™, in cooperation with DEWALT and other battery users, has established programs in the United States and Canada to facilitate the collection of spent nickel cadmium, nickel metal hydride or lithium ion batteries. Help protect our environment and conserve natural resources by returning the spent nickel cadmium, nickel metal hydride or lithium ion batteries to an authorized DEWALT service center or to your local retailer for recycling. You may also contact your local recycling center for information on where to drop off the spent battery.

RBRC™ is a registered trademark of the Rechargeable Battery Recycling Corporation.

**Important Safety Instructions for All Battery Chargers**

**SAVE THESE INSTRUCTIONS:** This manual contains important safety and operating instructions for battery chargers.

- Before using the charger, read all instructions and cautionary markings on the charger, battery pack and product using the battery pack.

**⚠ WARNING:** Shock hazard. Do not allow any liquid to get inside the charger. Electric shock may result.

**⚠ CAUTION:** Burn hazard. To reduce the risk of injury, charge only DEWALT rechargeable battery packs. Other types of batteries may overheat and burst resulting in personal injury and property damage.

**NOTICE:** Under certain conditions, with the charger plugged into the power supply, the charger can be shorted by foreign material. Foreign materials of a conductive nature, such as, but not limited to, grinding dust, metal chips, steel wool, aluminum foil or any buildup of metallic particles should be kept away from the charger cavities. Always unplug the charger from the power supply when there is no battery pack in the cavity. Unplug the charger before attempting to clean.

- DO NOT attempt to charge the battery pack with any chargers other than the ones in this manual. The charger and battery pack are specifically designed to work together.
- These chargers are not intended for any uses other than charging DEWALT rechargeable batteries. Any other uses may result in risk of fire, electric shock or electrocution.
- Do not expose the charger to rain or snow.
- Pull by the plug rather than the cord when disconnecting the charger. This will reduce the risk of damage to the electric plug and cord.
- Make sure that the cord is located so that it will not be stepped on, tripped over or otherwise subjected to damage or stress.
- Do not use an extension cord unless it is absolutely necessary. Use of improper extension cord could result in risk of fire, electric shock or electrocution.
- When operating a charger outdoors, always provide a dry location and use an extension cord suitable for outdoor use. Use of a cord suitable for outdoor use reduces the risk of electric shock.
- An extension cord must have adequate wire size (AWG or American Wire Gauge) for safety. The smaller the gauge number of the wire, the greater the capacity of the cable, that is, 16 gauge has more capacity than 18 gauge. An undersized cord will cause a drop in line voltage resulting in loss of power and overheating. When using more than one extension to make up the total length, be sure each individual extension contains at least the minimum wire size. The following table shows the correct size to use depending on cord length and nameplate ampere rating. If in doubt, use the next heavier gauge. The lower the gauge number, the larger the cord.

		Minimum Gauge for Cord Sets				
		Volts	Total Length of Cord in Feet (meters)			
Ampere Rating		120V	25 (7.6)	50 (15.2)	100 (30.5)	150 (45.7)
		240V	50 (15.2)	100 (30.5)	200 (61.0)	300 (91.4)
More Than	Not More Than	AWG				
0	6	18	16	16	14	
6	10	18	16	14	12	
10	12	16	16	14	12	
12	16	14	12	Not Recommended		

- Do not place any object on top of the charger or place the charger on a soft surface that might block the ventilation slots and result in excessive internal heat. Place the charger in a position away from any heat source. The charger is ventilated through slots in the top and the bottom of the housing.
- Do not operate the charger with a damaged cord or plug.
- Do not operate the charger if it has received a sharp blow, been dropped or otherwise damaged in any way. Take it to an authorized service center.

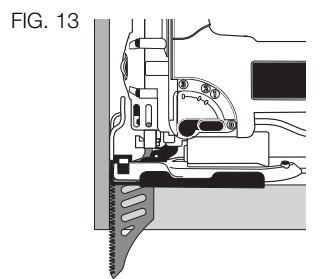
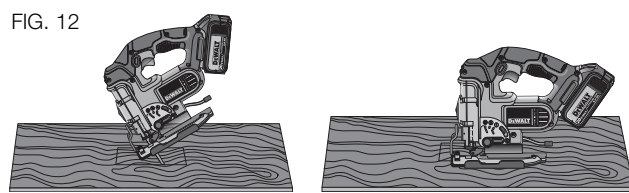
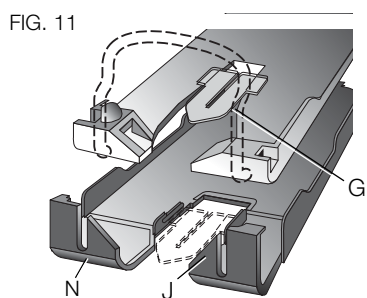
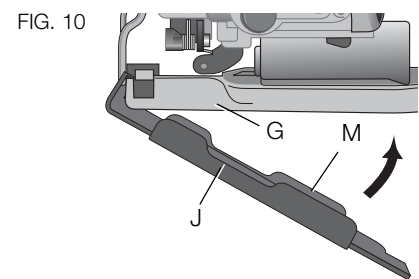
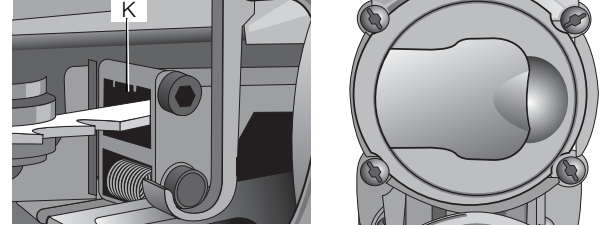
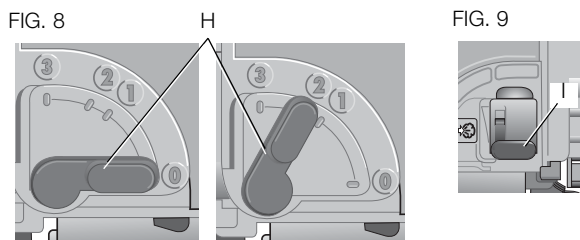
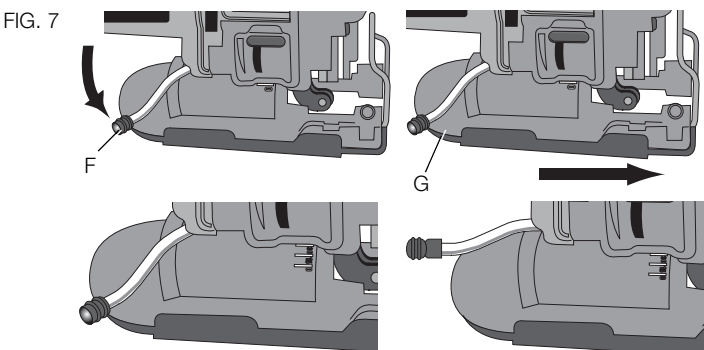
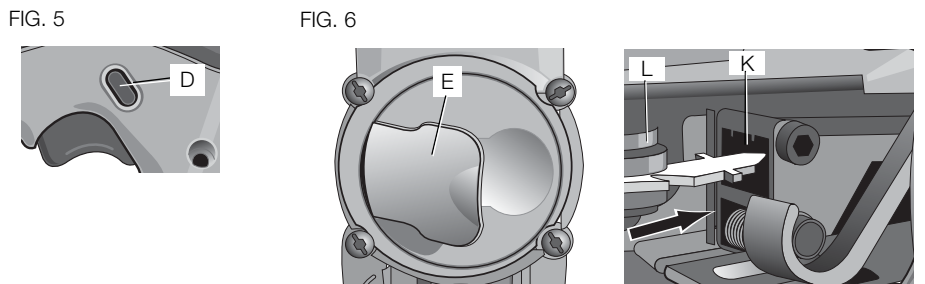
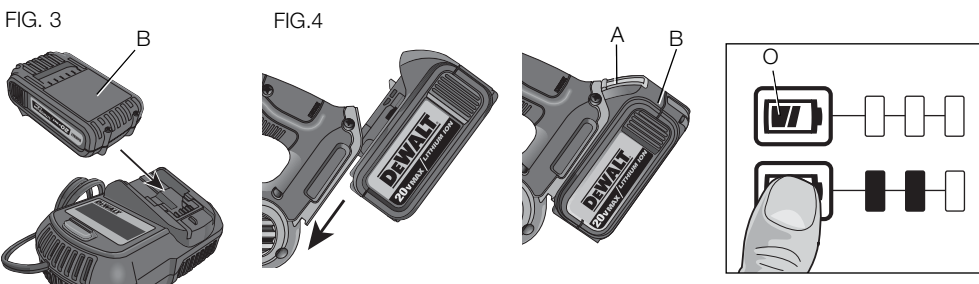
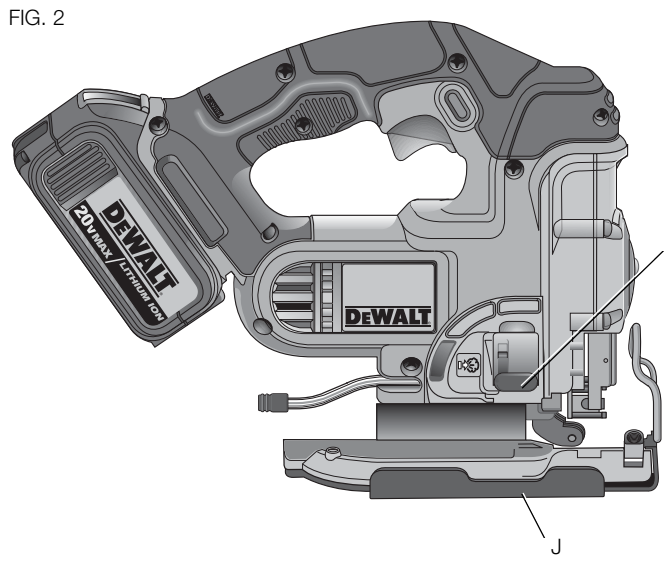
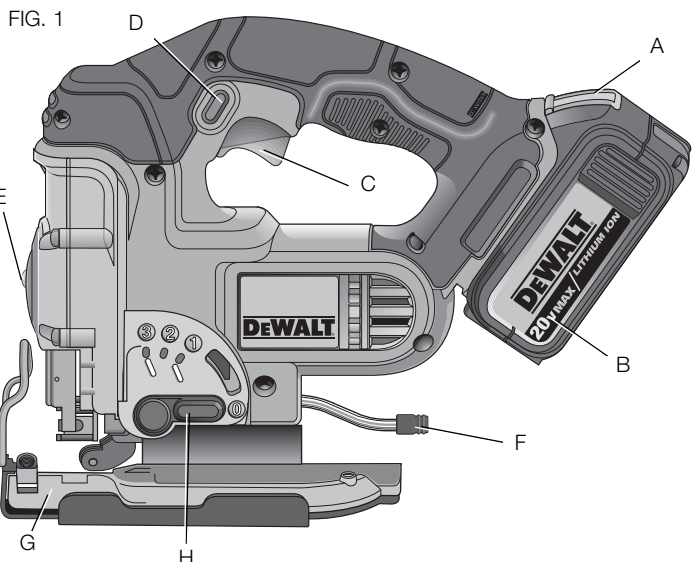

- **Do not disassemble the charger; take it to an authorized service center when service or repair is required.** Incorrect reassembly may result in a risk of electric shock, electrocution or fire.
- **Disconnect the charger from the outlet before attempting any cleaning.** This will reduce the risk of electric shock. Removing the battery pack will not reduce this risk.
- **NEVER** attempt to connect 2 chargers together.
- **The charger is designed to operate on standard 120V household electrical power. Do not attempt to use it on any other voltage.** This does not apply to the vehicular charger.

### Chargers

Your tool uses a DEWALT charger. Be sure to read all safety instructions before using your charger. Consult the chart at the end of this manual for compatibility of chargers and battery packs.

### Charging Procedure (Fig. 3)

1. Plug the charger into an appropriate outlet before inserting the battery pack.
2. Insert the battery pack (B) into the charger, as shown in Figure 3, making sure the pack is fully seated in charger. The red (charging) light will blink continuously, indicating that the charging process has started.
3. The completion of charge will be indicated by the red light remaining ON continuously. The pack is fully charged and may be used at this time or left in the charger.

### Indicator Light Operation

	PACK CHARGING	---
	PACK CHARGED	—
	HOT/COLD DELAY	— • — • — • — • — • — •
	PROBLEM PACK OR CHARGER	• • • • • • • • • •
	PROBLEM POWERLINE	• • • • • • • •

### Charge Indicators

This charger is designed to detect certain problems that can arise. Problems are indicated by the red light flashing at a fast rate. If this occurs, re-insert the battery pack into the charger. If the problem persists, try a different battery pack to determine if the charger is working properly. If the new pack charges correctly, then the original pack is defective and should be returned to a service center or other collection site for recycling. If the new battery pack elicits the same trouble indication as the original, have the charger and the battery pack tested at an authorized service center.

### HOT/COLD DELAY

This charger has a hot/cold delay feature: when the charger detects a battery that is hot, it automatically starts a delay, suspending charging until the battery has cooled. After the battery has cooled, the charger automatically switches to the pack charging mode. This feature ensures maximum battery life. The red light flashes long, then short while in the hot/cold delay mode.

### LEAVING THE BATTERY PACK IN THE CHARGER

The charger and battery pack can be left connected with the charge indicator showing Pack Charged.

**WEAK BATTERY PACKS:** Weak batteries will continue to function but should not be expected to perform as much work.

**FAULTY BATTERY PACKS:** This charger will not charge a faulty battery pack. The charger will indicate faulty battery pack by refusing to light or by displaying problem pack or charger.

**NOTE:** This could also mean a problem with a charger.

### PROBLEM POWER LINE

Some chargers have a Problem Powerline indicator. When the charger is used with some portable power sources such as generators or sources that convert DC to AC, the charger may temporarily suspend operation, flashing the red light with two fast blinks followed by a pause. This indicates the power source is out of limits.

### Important Charging Notes

1. Longest life and best performance can be obtained if the battery pack is charged when the air temperature is between 65 °F and 75 °F (18°–24 °C). DO NOT charge the battery pack in an air temperature below +40 °F (+4.5 °C), or above +105 °F (+40.5 °C). This is important and will prevent serious damage to the battery pack.
2. The charger and battery pack may become warm to the touch while charging. This is a normal condition, and does not indicate a problem. To facilitate the cooling of the battery pack after use, avoid placing the charger or battery pack in a warm environment such as in a metal shed or an uninsulated trailer.
3. A cold battery pack will charge at about half the rate of a warm battery pack. The battery pack will charge at that slower rate throughout the entire charging cycle and will not return to maximum charge rate even if the battery pack warms.
4. If the battery pack does not charge properly:
  - a. Check operation of receptacle by plugging in a lamp or other appliance;
  - b. Check to see if receptacle is connected to a light switch which turns power off when you turn out the lights;
  - c. Move the charger and battery pack to a location where the surrounding air temperature is approximately 65 °F–75 °F (18°–24 °C);
  - d. If charging problems persist, take the tool, battery pack and charger to your local service center.
5. The battery pack should be recharged when it fails to produce sufficient power on jobs which were easily done previously. DO NOT CONTINUE to use under these conditions. Follow the charging procedure. You may also charge a partially used pack whenever you desire with no adverse effect on the battery pack.
6. Foreign materials of a conductive nature such as, but not limited to, grinding dust, metal chips, steel wool, aluminum foil, or any buildup of metallic particles should be kept away from charger cavities. Always unplug the charger from the power supply when there is no battery pack in the cavity. Unplug the charger before attempting to clean.
7. Do not freeze or immerse the charger in water or any other liquid.

**WARNING:** Shock hazard. Don't allow any liquid to get inside the charger. Electric shock may result.

**WARNING:** Burn hazard. Do not submerge the battery pack in any liquid or allow any liquid to enter the battery pack. Never attempt to open the battery pack for any reason. If the plastic housing of the battery pack breaks or cracks, return to a service center for recycling.

### Storage Recommendations

1. The best storage place is one that is cool and dry, away from direct sunlight and excess heat or cold.
2. For longer storage, it is recommended to store a fully charged battery pack in a cool dry place out of the charger for optimal results.

**NOTE:** Battery packs should not be stored completely depleted of charge. The battery pack will need to be recharged before use.

### SAVE THESE INSTRUCTIONS FOR FUTURE USE

### Motor

Be sure your power supply agrees with the nameplate marking. Voltage decrease of more than 10% will cause loss of power and overheating. DEWALT tools are factory tested; if this tool does not operate, check power supply.

### COMPONENTS (Fig. 1, 2)

**WARNING:** Never modify the power tool or any part of it. Damage or personal injury could result.

- |                           |                         |
|---------------------------|-------------------------|
| A. Battery release button | F. Bevel lever          |
| B. Battery pack           | G. Shoe                 |
| C. Trigger switch         | H. Orbital action lever |
| D. Trigger lock button    | I. Dust blower control  |
| E. Blade release lever    | J. No-mar shoe cover    |

### INTENDED USE

Your DCS331 jig saw is designed for professional cutting of wood, steel, aluminium, plastic and ceramic material.

**DO NOT** use under wet conditions or in presence of flammable liquids or gases.

This jig saw is a professional power tool. **DO NOT** let children come into contact with the tool. Supervision is required when inexperienced operators use this tool.

### Trigger Switch (Fig. 1)

**To start the jig saw,** squeeze the trigger switch (C).

**To slow and stop the jig saw,** release the trigger switch.

### VARIABLE SPEED (FIG. 5)

As the trigger switch is pressed in, the strokes-per-minute continue to increase, but not to exceed the maximum speed of the tool. As the trigger is released, the blade strokes-per-minute reduce. The trigger lock button (D) should be depressed whenever the tool is not in use to eliminate the chance of accidental starting.

### ASSEMBLY AND ADJUSTMENTS

**WARNING:** To reduce the risk of serious personal injury, depress the trigger lock button and disconnect battery pack before making any adjustments or removing/installing attachments or accessories. An accidental start-up can cause injury.

### Blade Installation and Removal (Fig. 6)

#### TO INSTALL A BLADE

**NOTE:** This jig saw uses only T-shank jig saw blades.

**NOTE:** The DT2074 flush cutting blade is for use with DEWALT DCS331, DW331 and DC330 jig saws only.

**NOTE:** When installing flush cutting blades (DT2074), the anti-splinter insert must be removed and the shoe must be in the 0° positive stop position.

1. Lift the keyless blade release lever (E) as shown in Figure 6.
2. Insert the T-shank blade into the clamp mechanism (K) while guiding the back of the blade into the groove of the guide rollers (L).
3. The T-shank should be completely inside the clamp mechanism as shown in Figure 6.
4. Release the keyless blade release lever.

#### TO REMOVE A BLADE

**CAUTION:** Do not touch used blades, they may be hot. Personal injury may result.

1. Lift the keyless blade release lever (E).
2. With a slight shake the blade will drop out.

### Beveling the Shoe (Fig. 7)

**To unlock the shoe,** pull the keyless bevel lever (F) to the side.

**To lock the shoe,** push the keyless bevel lever back under the body of the jigsaw.

#### TO BEVEL THE SHOE

1. Unlock the shoe.
2. Slide the shoe (G) forward to release it from the 0° positive stop position.
3. The shoe can be beveled to the left or to the right and has detents at 15°, 30° and 45°. The shoe can be manually stopped at any degree between 0° and 45°.
4. Once the desired bevel angle is achieved, lock the shoe into place.

#### TO SET SHOE BACK TO 0°

1. Unlock the shoe.
2. Rotate the shoe back to 0°.
3. Slide the shoe back into the 0° positive stop position.
4. Lock the shoe.

### Cutting Action – Orbital or Straight (Fig. 8)

This jig saw is equipped with four cutting actions, three orbital and one straight. Orbital action has a more aggressive blade motion and is designed for cutting in soft materials like wood or plastic. Orbital action provides a faster cut, but with a less smooth cut across the material. In orbital action, the blade moves forward during the cutting stroke in addition to the up and down motion.

**NOTE:** Metal or hardwoods should never be cut in orbital action.

**To adjust the cutting action,** move the orbital action lever (H) between the four cutting positions: 0, 1, 2, and 3. Position 0 is straight cutting. Positions 1, 2, and 3 are orbital cutting. The aggressiveness of the cut increase as the lever is adjusted from one to three, with three being the most aggressive cut.

### Dust Blower (Fig. 9)

The dust blower helps clear the cutting area of debris created from the blade.

**NOTE:** When cutting metal, turn the dust blower off so cutting fluids are not blown away from the blade.

**To turn the dust blower on,** slide the dust blower control (I) all the way to the top.

**To turn the dust blower off,** slide the dust blower control all the way to the bottom.

### Removeable No-Mar Shoe Cover (Fig. 10)

The no-mar shoe cover (J) should be used when cutting surfaces that scratch easily, such as laminate, veneer or paint.

**To attach no-mar shoe cover,** place the front of the aluminum shoe (G) into the front of the no-mar shoe cover (J) and lower the jig saw. The no-mar shoe will click securely onto the rear of aluminum shoe.

**To remove no-mar shoe cover,** grasp the no-mar shoe cover from the bottom; holding onto the two rear tabs (M) remove the no-mar shoe cover.

### Anti-Splinter Insert (Fig. 11)

**NOTE:** Do not use the anti-splinter insert with the flush cutting blade.

The anti-splinter insert (N) should be used when trying to minimize tear-out, especially when cutting veneer, laminate, or finished surfaces, such as paint. The anti-splinter insert should be installed into the no-mar shoe cover (J). If the no-mar cover is not used, install anti-splinter insert into shoe (G).

### OPERATION

**WARNING:** To reduce the risk of serious personal injury, depress the trigger lock button and disconnect battery pack before making any adjustments or removing/installing attachments or accessories. An accidental start-up can cause injury.

### Installing and Removing the Battery Pack (Fig. 4)

**NOTE:** For best results, make sure your battery pack is fully charged.

To install the battery pack (B) into the tool handle, align the battery pack with the rails inside the tool's handle and slide it into the handle until the battery pack is firmly seated in the tool and ensure that it does not disengage.

To remove the battery pack from the tool, press the release button (A) and firmly pull the battery pack out of the tool handle. Insert it into the charger as described in the charger section of this manual.

### FUEL GAUGE BATTERY PACKS (FIG. 4)

Some DEWALT battery packs include a fuel gauge which consists of three green LED lights that indicate the level of charge remaining in the battery pack.

To activate the fuel gauge, press and hold the fuel gauge button (O). A combination of the three green LED lights will illuminate designating the level of charge left. When the level of charge in the battery is below the usable limit, the fuel gauge will not illuminate and the battery will need to be recharged.

**NOTE:** The fuel gauge is only an indication of the charge left on the battery pack. It does not indicate tool functionality and is subject to variation based on product components, temperature and end-user application.

## Cutting

**⚠ WARNING:** *The jig saw should not be operated with the shoe removed or serious personal injury may result.*

### POCKET CUTTING (FIG. 12)

A pocket cut is an easy method of making an inside cut. The saw can be inserted directly into a panel or board without first drilling a lead or pilot hole. In pocket cutting, measure the surface to be cut and mark clearly with a pencil. Next tip the saw forward until the front end of the shoe sits firmly on the work surface and the blade clears the work through its full stroke. Switch the tool on and allow it to attain maximum speed. Grip the saw firmly and lower the back edge of tool slowly until the blade reaches its complete depth. Hold the shoe flat against the wood and begin cutting. Do not remove blade from cut while it is still moving. Blade must come to a complete stop.

### FLUSH CUTTING (FIG. 13)

A flush cut is necessary when finishing off cuts up to a wall or an obstacle, such as back-splash. One of the easiest ways to accomplish the flush cut is to use a flush cutting blade (DT2074). The flush cutting blade provides the reach necessary to cut right up to the front edge of the jig saw shoe. Remove the anti-splinter insert and return the shoe to the 0° positive stop position before installing and using the flush cutting blade. For the best cut quality the flush cutting blade should be used in the 0 or 1 orbital position. The flush cutting blade should not be used to start the cut because the flush cutting blade prevents the shoe from being supported by the work surface. Use wood cutting practices explained below.

### WOOD CUTTING

Support the workpiece adequately at all times. Use the higher speed setting for cutting wood. Do not attempt to turn the tool on when blade is against material to be cut. This could stall the motor. Place the front of shoe on the material to be cut and hold the jig saw shoe firmly against the wood while cutting. Don't force the tool; let the blade cut at its own speed. When the cut is complete, turn the jig saw off. Let blade come to a complete stop and then lay the saw aside before loosening the work.

### METAL CUTTING

In cutting thin gauge sheet metals, it is best to clamp wood to the bottom of sheet metal; this will insure a clean cut without the risk of vibration or tearing of metal. Always remember to use a finer blade for ferrous metals (for those that have a high iron content); and use a coarser blade for non-ferrous metals (those that do not have an iron content). Use a high speed setting for cutting soft metals (aluminum, copper, brass, mild steel, galvanized pipe, conduit sheet metal, etc.). Use lower speed to cut plastics, tile, laminate, hard metals, and cast iron.

## MAINTENANCE

**⚠ WARNING:** *To reduce the risk of serious personal injury, depress the trigger lock button and disconnect battery pack before making any adjustments or removing/installing attachments or accessories. An accidental start-up can cause injury.*

### Cleaning

**⚠ WARNING:** *Blow dirt and dust out of all air vents with clean, dry air at least once a week. To minimize the risk of eye injury, always wear ANSI Z87.1 approved eye protection when performing this.*

**⚠ WARNING:** *Never use solvents or other harsh chemicals for cleaning the non-metallic parts of the tool. These chemicals may weaken the plastic materials used in these parts. Use a cloth dampened only with water and mild soap. Never let any liquid get inside the tool; never immerse any part of the tool into a liquid.*

### CHARGER CLEANING INSTRUCTIONS

**⚠ WARNING:** *Shock hazard. Disconnect the charger from the AC outlet before cleaning. Dirt and grease may be removed from the exterior of the charger using a cloth or soft non-metallic brush. Do not use water or any cleaning solutions.*

### Accessories

**⚠ WARNING:** *Since accessories, other than those offered by DEWALT, have not been tested with this product, use of such accessories with this tool could be hazardous. To reduce the risk of injury, only DEWALT recommended accessories should be used with this product.*

Recommended accessories for use with your tool are available at extra cost from your local dealer or authorized service center.