

MANUAL



DWD210G, DWD215G, DWD216G, DWD220
Heavy-Duty 1/2" (13 mm) Drill

(SEP13) Part No. N360082 DWD210G, DWD215G, DWD216G, DWD220

The following are trademarks for one or more DEWALT power tools: the yellow and black color scheme, the "D" shaped air intake grill, the array of pyramids on the handgrip, the kit box configuration, and the array of lozenge-shaped humps on the surface of the tool.

Definitions: Safety Guidelines

The definitions below describe the level of severity for each signal word. Please read the manual and pay attention to these symbols.

▲ DANGER: Indicates an imminently hazardous situation which, if not avoided, **will** result in **death or serious injury**.

▲ WARNING: Indicates a potentially hazardous situation which, if not avoided, **could** result in **death or serious injury**.

▲ CAUTION: Indicates a potentially hazardous situation which, if not avoided, **may** result in **minor or moderate injury**.

NOTICE: Indicates a practice **not related to personal injury** which, if not avoided, **may** result in **property damage**.



WARNING: To reduce the risk of injury, read the instruction manual.

General Power Tool Safety Warnings

WARNING! Read all safety warnings and all instructions. Failure to follow the warnings and instructions may result in electric shock, fire and/or serious injury.

SAVE ALL WARNINGS AND INSTRUCTIONS FOR FUTURE REFERENCE

The term "power tool" in the warnings refers to your mains-operated (corded) power tool or battery-operated (cordless) power tool.

1) WORK AREA SAFETY

- a) **Keep work area clean and well lit.** Cluttered or dark areas invite accidents.
- b) **Do not operate power tools in explosive atmospheres, such as in the presence of flammable liquids, gases or dust.** Power tools create sparks which may ignite the dust or fumes.
- c) **Keep children and bystanders away while operating a power tool.** Distractions can cause you to lose control.

2) ELECTRICAL SAFETY

- a) **Power tool plugs must match the outlet. Never modify the plug in any way. Do not use any adapter plugs with earthed (grounded) power tools.** Unmodified plugs and matching outlets will reduce risk of electric shock.
- b) **Avoid body contact with earthed or grounded surfaces such as pipes, radiators, ranges and refrigerators.** There is an increased risk of electric shock if your body is earthed or grounded.
- c) **Do not expose power tools to rain or wet conditions.** Water entering a power tool will increase the risk of electric shock.
- d) **Do not abuse the cord. Never use the cord for carrying, pulling or unplugging the power tool. Keep cord away from heat, oil, sharp edges or moving parts.** Damaged or entangled cords increase the risk of electric shock.
- e) **When operating a power tool outdoors, use an extension cord suitable for outdoor use.** Use of a cord suitable for outdoor use reduces the risk of electric shock.
- f) **If operating a power tool in a damp location is unavoidable, use a ground fault circuit interrupter (GFCI) protected supply.** Use of a GFCI reduces the risk of electric shock.

3) PERSONAL SAFETY

- a) **Stay alert, watch what you are doing and use common sense when operating a power tool. Do not use a power tool while you are tired or under the influence of drugs, alcohol or medication.** A moment of inattention while operating power tools may result in serious personal injury.
- b) **Use personal protective equipment. Always wear eye protection.** Protective equipment such as dust mask, non-skid safety shoes, hard hat, or hearing protection used for appropriate conditions will reduce personal injuries.

- c) **Prevent unintentional starting. Ensure the switch is in the off position before connecting to power source and/or battery pack, picking up or carrying the tool.** Carrying power tools with your finger on the switch or energizing power tools that have the switch on invites accidents.
- d) **Remove any adjusting key or wrench before turning the power tool on.** A wrench or a key left attached to a rotating part of the power tool may result in personal injury.
- e) **Do not overreach. Keep proper footing and balance at all times.** This enables better control of the power tool in unexpected situations.
- f) **Dress properly. Do not wear loose clothing or jewelry. Keep your hair, clothing and gloves away from moving parts.** Loose clothes, jewelry or long hair can be caught in moving parts.
- g) **If devices are provided for the connection of dust extraction and collection facilities, ensure these are connected and properly used.** Use of dust collection can reduce dust-related hazards.

4) POWER TOOL USE AND CARE

- a) **Do not force the power tool. Use the correct power tool for your application.** The correct power tool will do the job better and safer at the rate for which it was designed.
- b) **Do not use the power tool if the switch does not turn it on and off.** Any power tool that cannot be controlled with the switch is dangerous and must be repaired.
- c) **Disconnect the plug from the power source and/or the battery pack from the power tool before making any adjustments, changing accessories, or storing power tools.** Such preventive safety measures reduce the risk of starting the power tool accidentally.
- d) **Store idle power tools out of the reach of children and do not allow persons unfamiliar with the power tool or these instructions to operate the power tool.** Power tools are dangerous in the hands of untrained users.
- e) **Maintain power tools. Check for misalignment or binding of moving parts, breakage of parts and any other condition that may affect the power tool's operation. If damaged, have the power tool repaired before use.** Many accidents are caused by poorly maintained power tools.
- f) **Keep cutting tools sharp and clean.** Properly maintained cutting tools with sharp cutting edges are less likely to bind and are easier to control.
- g) **Use the power tool, accessories and tool bits, etc. in accordance with these instructions, taking into account the working conditions and the work to be performed.** Use of the power tool for operations different from those intended could result in a hazardous situation.

5) SERVICE

- a) **Have your power tool serviced by a qualified repair person using only identical replacement parts.** This will ensure that the safety of the power tool is maintained.

Additional Safety Rules

- **Use auxiliary handle(s), if supplied with the tool.** Loss of control can cause personal injury.
- **Hold power tool by insulated gripping surfaces, when performing an operation where the cutting accessory may contact hidden wiring or its own cord.** Cutting accessory contacting a "live" wire may make exposed metal parts of the power tool "live" and could give the operator an electric shock.
- **Wear ear protectors with impact drills.** Exposure to noise can cause hearing loss.
- **ALWAYS use the side handle supplied with the tool.** Tighten the side handle securely before use. Keep a firm grip on the tool at all times. Do not attempt to operate this tool without holding it with both hands. Operating this tool with one hand will result in loss of control. Breaking through may be hazardous as well.
- **Use clamps or other practical way to secure and support the workpiece to a stable platform.** Holding the work by hand or against your body is unstable and may lead to loss of control.
- **Keep handles dry, clean, free from oil and grease.** It is recommended to use rubber gloves. This will enable better control.
- **Air vents often cover moving parts and should be avoided.** Loose clothes, jewellery or long hair can be caught in moving parts.
- **An extension cord must have adequate wire size (AWG or American Wire Gauge) for safety.** The smaller the gauge number of the wire, the greater the capacity of the cable, that is 16 gauge has more capacity than 18 gauge. An undersized cord will cause a drop in line voltage resulting in loss of power and overheating. When using more than one extension to make up the total length, be sure each individual extension contains at least the minimum wire size. The following table shows the correct size to use depending on cord length and nameplate ampere rating. If in doubt, use the next heavier gauge. The smaller the gauge number, the heavier the cord.

		Minimum Gauge for Cord Sets				
		Volts	Total Length of Cord in Feet (meters)			
Ampere Rating		120V	25 (7.6)	50 (15.2)	100 (30.5)	150 (45.7)
		240V	50 (15.2)	100 (30.5)	200 (61.0)	300 (91.4)
More Than	Not More Than	AWG				
0	6		18	16	16	14
6	10		18	16	14	12
10	12		16	16	14	12
12	16		14	12	Not Recommended	

▲ WARNING: ALWAYS use safety glasses. Everyday eyeglasses are NOT safety glasses. Also use face or dust mask if cutting operation is dusty. ALWAYS WEAR CERTIFIED SAFETY EQUIPMENT:

- ANSI Z87.1 eye protection (CAN/CSA Z94.3),
- ANSI S12.6 (S3.19) hearing protection,
- NIOSH/OSHA/MSHA respiratory protection.

▲ WARNING: Some dust created by power sanding, sawing, grinding, drilling, and other construction activities contains chemicals known to the State of California to cause cancer, birth defects or other reproductive harm. Some examples of these chemicals are:

- lead from lead-based paints,
- crystalline silica from bricks and cement and other masonry products, and
- arsenic and chromium from chemically-treated lumber.

Your risk from these exposures varies, depending on how often you do this type of work. To reduce your exposure to these chemicals: work in a well ventilated area, and work with approved safety equipment, such as those dust masks that are specially designed to filter out microscopic particles.

- **Avoid prolonged contact with dust from power sanding, sawing, grinding, drilling, and other construction activities. Wear protective clothing and wash exposed areas with soap and water.** Allowing dust to get into your mouth, eyes, or lay on the skin may promote absorption of harmful chemicals.

▲ WARNING: Use of this tool can generate and/or disperse dust, which may cause serious and permanent respiratory or other injury. Always use NIOSH/OSHA approved respiratory protection appropriate for the dust exposure. Direct particles away from face and body.

▲ WARNING: Always wear proper personal hearing protection that conforms to ANSI S12.6 (S3.19) during use. Under some conditions and duration of use, noise from this product may contribute to hearing loss.

- The label on your tool may include the following symbols. The symbols and their definitions are as follows:

V.....volts	A.....amperes
Hz.....hertz	W.....watts
minminutes	~ or AC.....alternating current
=== or DC.....direct current	⎓ or AC/DC.....alternating or direct current
Ⓛ.....Class I Construction (grounded)	n _ono load speed
Ⓜ.....Class II Construction (double insulated)	n.....rated speed
.../minper minute	Ⓧ.....earthing terminal
IPM.....impacts per minute	▲.....safety alert symbol
SPMstrokes per minute	BPM.....beats per minute
	RPM.....revolutions per minute
	sfpM.....surface feet per minute

SAVE THESE INSTRUCTIONS FOR FUTURE USE

Motor

Be sure your power supply agrees with the nameplate marking. Voltage decrease of more than 10% will cause loss of power and overheating. DEWALT tools are factory tested; if this tool does not operate, check power supply.

COMPONENTS (Fig. 1, 6)

⚠WARNING: Never modify the power tool or any part of it. Damage or personal injury could result.

- A. Trigger switch
- B. Reversing lever
- C. Side handle
- D. Chuck
- E. Indicator light (DWD220)

INTENDED USE

These heavy-duty drills are designed for professional drilling applications. **DO NOT** use under humid conditions or in presence of flammable liquids or gases.

These heavy-duty drills are professional power tools. **DO NOT** let children come into contact with the tool. Supervision is required when inexperienced operators use this tool.

Side Handle (Fig. 1)

⚠WARNING: To reduce the risk of personal injury, ALWAYS operate the tool with the side handle properly installed and tightened. Failure to do so may result in the side handle slipping during tool operation and subsequent loss of control. Hold tool with both hands to maximize control.

A side handle (C) is supplied with your drill. The side handle clamps to the front of the gear case and can be rotated 360 degrees to permit right- or left-hand use.

After the side handle is rotated into position, it should be pushed rearward until the slots (H) on the lip of the side handle are aligned and fully engaged with the projecting tabs (G) on the underside of the gear case. The side handle is then securely clamped by turning clockwise until tight.

Trigger Switch (Fig. 2)

To start drill, depress trigger switch (A); to stop the drill, release trigger.

VARIABLE SPEED TRIGGER SWITCH (FIG. 2)

The variable speed trigger switch (A) permits speed control. The farther the trigger switch is depressed, the higher the speed of the drill.

NOTE: Use lower speeds for starting holes, drilling in plastics or ceramics or driving screws.

REVERSING LEVER (FIG. 2)

The reversing lever (B), located above the trigger switch, changes the direction of rotation of the drill and is used when backing out screws and jammed drill bits.

To operate the tool in reverse, release the trigger switch and push the lever to the left (when viewed from the chuck end).

To operate the drill in forward, release the trigger switch and push the lever to the right (when viewed from the chuck end).

Return the reversing lever to the forward position after all operations in reverse are completed.

E-Clutch™ Anti-Lock Control (Fig. 6)

DWD220

Your DEWALT drill may come with an electronic feature called E-Clutch™ Anti-Lock Control. It is designed to help you control the drill during a stall and keep it from pulling out of your hands. This may be encountered when drilling in steel or using large bits in wood.

As a stall situation presents itself, the motor cycles on and off for a set period of time. This takes up the reaction of the stall and allows you to keep the drill under control. The speed control senses your release of the trigger and resets the motor to run again.

Figure 6 shows the instruction label (H) mounted on the housing. There are two alert modes.

- Engaged Mode:** When a stall situation presents itself, the indicator light (E) will come on and stay on as the motor cycles on and off for a set period of time before the E-Clutch™ Anti-Lock Control completely shuts the tool down. When the unit is running in normal mode, there will be no light.
- Problem Mode:** A series of continual flashes of the indicator light as the trigger is pulled indicates that the electronics are no longer functioning. The tool may still be able to function without the benefit of E-Clutch™ Anti-Lock Control but should be serviced as soon as possible.

OPERATION

⚠WARNING: To reduce the risk of serious personal injury, turn tool off and disconnect tool from power source before making any adjustments or removing/installing attachments or accessories. An accidental start-up can cause injury.

⚠WARNING: To reduce the risk of personal injury, ALWAYS ensure workpiece is anchored or clamped firmly. If drilling thin material, use a wood "back-up" block to prevent damage to the material.

⚠WARNING: To reduce the risk of personal injury, ALWAYS operate the tool with the side handle properly installed. Failure to do so may result in the side handle slipping during tool operation and subsequent loss of control. Hold tool with both hands to maximize control.

⚠WARNING: Do not attempt to tighten or loosen drill bits (or any other accessory) by gripping the front part of the chuck and turning the tool on. Damage to the chuck and personal injury may occur.

Keyed Chucks (Fig. 1)

DWD210G, DWD216G, DWD220

Open chuck jaws by turning collar with fingers and insert shank of bit about 3/4" (19 mm) into chuck. Tighten chuck collar by hand. Place chuck key in each of the three holes, and tighten in CLOCKWISE direction. It's important to tighten chuck with all three holes to prevent slippage. To release bit, turn chuck key COUNTERCLOCKWISE in just one hole, then loosen the chuck by hand. Any authorized DEWALT service center can install a keyless chuck in place of a keyed chuck.

Keyless Chucks (Fig. 1, 3-5)

DWD215G

The DWD215G features a keyless chuck with one rotating sleeve for one-handed operation of the chuck.

TO INSERT A DRILL BIT OR OTHER ACCESSORY

- Grasp the black sleeve of the chuck (D) with one hand and use the other hand to secure the tool. Rotate the sleeve counterclockwise far enough to accept the desired accessory (Fig. 3).
- Insert the accessory about 3/4" (19 mm) into the chuck and tighten securely by rotating the chuck sleeve clockwise with one hand while holding the tool with the other hand. Continue to rotate the chuck sleeve until several ratchet clicks are heard to ensure full gripping power.

To release the accessory, repeat Step 1 above.

Be sure to tighten chuck with one hand on the chuck sleeve and one hand holding the tool for maximum tightness.

Drilling

- Use sharp drill bits only. For WOOD, begin with low speed and use twist drill bits, spade bits, power auger bits or hole saws. For METAL, begin with low speed and use steel twist drill bits or hole saws. Use a cutting lubricant when drilling metals. The exceptions are cast iron and brass which should be drilled dry.

NOTE: Large [5/16" (8 mm) to 1/2" (13 mm)] holes in steel can be made easier if a pilot hole [5/32" (4 mm) to 3/16" (5 mm)] is drilled first.

- Always apply pressure in a straight line with the bit. Use enough pressure to keep drill biting, but do not push hard enough to stall the motor or deflect the bit.
- Hold tool firmly with both hands to control the twisting action of the drill.

⚠WARNING: Drill may stall if overloaded causing a sudden twist. Always expect the stall. Grip the drill firmly with both hands to control the twisting action and avoid injury.

- IF DRILL STALLS,** it is usually because it is being overloaded or improperly used. **RELEASE TRIGGER IMMEDIATELY,** remove drill bit from work, and determine cause of stalling. **DO NOT CLICK TRIGGER ON AND OFF IN AN ATTEMPT TO START A STALLED DRILL — THIS CAN DAMAGE THE DRILL.**

- To minimize stalling or breaking through the material, reduce pressure on drill and ease the bit through the last fractional part of the hole.

- Keep the motor running when pulling the bit back out of a drilled hole. This will help prevent jamming.

- With variable speed drills there is no need to center punch the point to be drilled. Use a slow speed to start the hole and accelerate by squeezing the trigger harder when the hole is deep enough to drill without the bit skipping out.

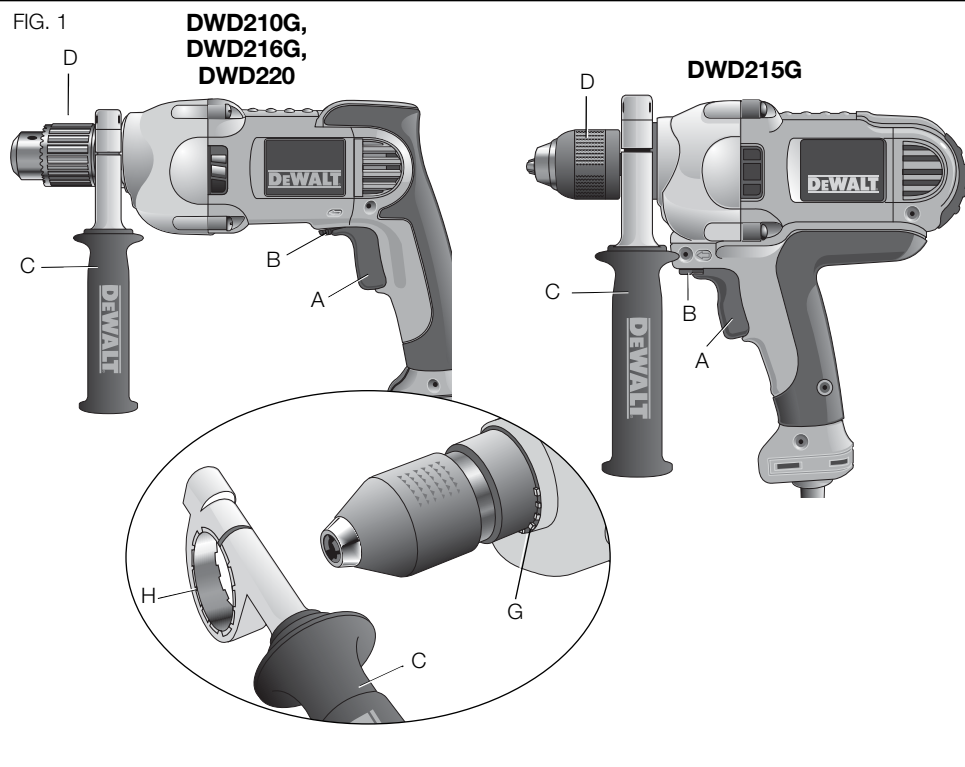

FIG. 2

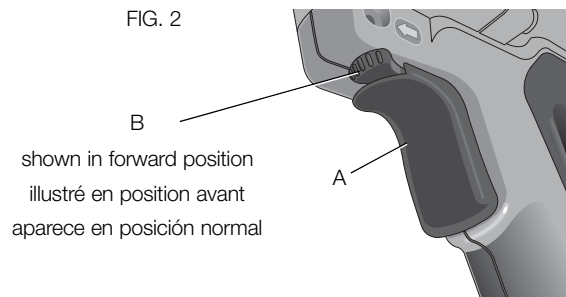

FIG. 3

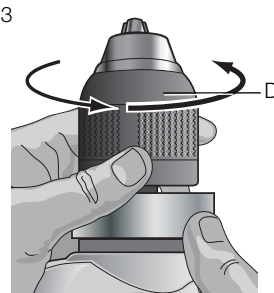

FIG. 4

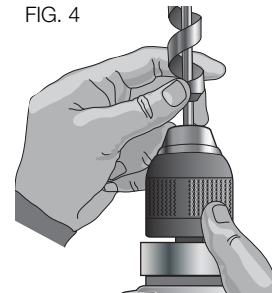

FIG. 5

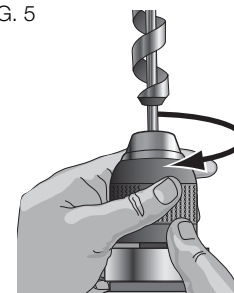
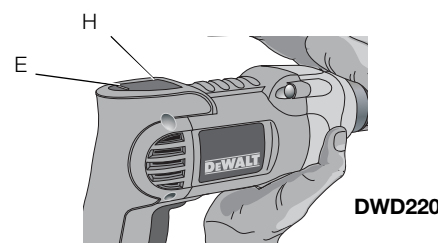

FIG. 6



MAINTENANCE

⚠WARNING: To reduce the risk of serious personal injury, turn tool off and disconnect tool from power source before making any adjustments or removing/installing attachments or accessories. An accidental start-up can cause injury.

Cleaning

⚠WARNING: Blow dirt and dust out of all air vents with clean, dry air at least once a week. To minimize the risk of eye injury, always wear ANSI Z87.1 approved eye protection when performing this.

⚠WARNING: Never use solvents or other harsh chemicals for cleaning the non-metallic parts of the tool. These chemicals may weaken the plastic materials used in these parts. Use a cloth dampened only with water and mild soap. Never let any liquid get inside the tool; never immerse any part of the tool into a liquid.

Lubrication

Self-lubricating bearings are used in the tool and periodic relubrication is not required. In the unlikely event that service is ever needed, take your tool to an authorized service location.

Accessories

⚠WARNING: Since accessories, other than those offered by DEWALT, have not been tested with this product, use of such accessories with this tool could be hazardous. To reduce the risk of injury, only DEWALT recommended accessories should be used with this product.

Recommended accessories for use with your tool are available at extra cost from your local dealer or authorized service center.

	DWD210G, DWD215G, DWD216G	DWD220
CHUCK CAPACITY	1/2" (13 mm)	1/2" (13 mm)
R.P.M.	0-1,250	0-1,200
BITS, METAL DRILLING	1/2" (13 mm)	1/2" (13 mm)
WOOD, FLAT BORING	1-1/2" (40 mm)	1-1/2" (40 mm)

Repairs

To assure product SAFETY and RELIABILITY, repairs, maintenance and adjustment (including brush inspection and replacement) should be performed by a DEWALT factory service center, a DEWALT authorized service center or other qualified service personnel. Always use identical replacement parts.

Register Online

Thank you for your purchase. Register your product now for:

- WARRANTY SERVICE:** Registering your product will help you obtain more efficient warranty service in case there is a problem with your product.
- CONFIRMATION OF OWNERSHIP:** In case of an insurance loss, such as fire, flood or theft, your registration of ownership will serve as your proof of purchase.
- FOR YOUR SAFETY:** Registering your product will allow us to contact you in the unlikely event a safety notification is required under the Federal Consumer Safety Act.

Learn more about drills and drivers we have.