

### INSTRUCTION MANUAL

#### Air Supply Requirements

1. Supply tool with 90 psig (6.2 bar) of clean, dry air. Higher pressure drastically reduces tool life.
2. Connect tool to air line using pipe, hose, and fitting sizes shown in the diagram on page 12.

#### Lubrication

1. Use an air line lubricator with SAE #10 oil, adjusted to two (2) drops per minute. If an air line lubricator cannot be used, add air motor oil to the inlet once a day.
2. Monthly, lubricate the drive bushing and ratchet yoke with a good grade bearing grease. Periodically, depending upon use, the ratchet head assembly should be removed, cleaned and re-greased.

#### Noise & Vibration Declaration\*

Sound pressure level 98.2 dB(A) in accordance with Pneuop 8N-1. For sound power, add 10 dB(A).  
Vibration value 7.2 m/s<sup>2</sup>, re. ISO 8662-1.

#### Maintenance

1. Disassemble and inspect air motor every three (3) months if the tool is used every day. Replace damaged or worn parts.
2. High wear parts are underlined in the parts list.
3. To keep downtime to a minimum, the following service kits, detailed on page 12, are recommended: CA146437 Tune-Up Kit, CA146436 Ratchet Head Replacement Kit (CP886), CA147668 Ratchet Head Replacement Kit (CP886H)

\* These declared values were obtained by laboratory type testing in compliance with the stated standards and are not adequate for use in risk assessments. Values measured in individual work places may be higher than the declared values. The actual exposure values and risk of harm experienced by an individual user are unique and depend upon the way the user works, the workpiece and the workstation design, as well as upon the exposure time and the physical condition of the user. We, Chicago Pneumatic, cannot be held liable for the consequences of using the declared values, instead of values reflecting the actual exposure, in an individual risk assessment in a work place situation over which we have no control.

### EC DECLARATION OF CONFORMITY

We, Chicago Pneumatic Tool Company, 1800 Overview Drive, Rock Hill, SC 29730 USA, declare under our sole responsibility that the product to which this declaration relates, is in conformity with the requirements of the Council Directive of June 1989 on the approximation of the laws of the Member States relating to machinery (89/392/EEC).

**Machine Name** CP886/886H Air Ratchet

**Machine Type** Assembly Power Tool for Threaded Fasteners - No other use is permitted.

**Serial No.** Tools with No. 94300A or higher

#### Technical Data

3/8" (10 mm) Sq. Dr. Std. (CP886),  
1/2" (13 mm) Sq. Dr. Std. (CP886H)  
Air pressure 90 psi (6.2 bar)  
Torque range 10-50 ft.-lb. (13-70 Nm)  
Ult. torque @ 90 psi (6.2 bar) 125 ft.-lb. (170 Nm)

**Harmonized Standards Applied** EN292

**National Standards Applied** ISO 8662-1, Pneuop 8N-1

**Name And Position Of Issuer** W.A. LeNeveu, President, Chicago Pneumatic Tool Company

**Signature Of Issuer** 

**Place And Date Of Issue** Utica, NY 13501 USA, November 1, 1994



## WARNING

To reduce risk of injury, everyone using, installing, repairing, maintaining, changing accessories on, or working near this tool must read and understand these instructions before performing any such task.

The goal of Chicago Pneumatic is to produce tools that help you work safely and efficiently. The most important safety device for this or any tool is YOU. Your care and good judgment are the best protection against injury. All possible hazards cannot be covered here, but we have tried to highlight some of the important ones.

#### For additional safety information consult:

- ⚠ Your employer, union and/or trade association.
- ⚠ US Department of Labor (OSHA); [www.osha.gov](http://www.osha.gov); Council of the European Communities [europe.osha.eu.int](http://europe.osha.eu.int)
- ⚠ Safety Code for Portable Air Tools (B186.1) available from: [www.ansi.com](http://www.ansi.com)
- ⚠ Safety Requirement for Hand-Held Non-Electric Power Tools available from: European Committee for Standardization, [www.cenorm.be](http://www.cenorm.be)

#### Air Supply and Connection Hazards

- ⚠ Air under pressure can cause severe injury.
- ⚠ Always shut off air supply, drain hose of air pressure and disconnect tool from air supply when not in use, before changing accessories or when making repairs.
- ⚠ Never direct air at yourself or anyone else.
- ⚠ Whipping hoses can cause serious injury. Always check for damaged or loose hoses and fittings.
- ⚠ Do not use quick disconnect couplings at tool. See instructions for correct set-up.
- ⚠ Whenever universal twist couplings are used, lock pins must be installed.
- ⚠ Do not exceed maximum air pressure of 90 psi/6.2 bar or as stated on tool nameplate.

#### Entanglement Hazards

- ⚠ Keep away from rotating drive.
- ⚠ Do not wear jewelry or loose clothing.
- ⚠ Choking can occur if neckwear is not kept away from the tool and accessories.
- ⚠ Scalping can occur if hair is not kept away from the tool and accessories.
- ⚠ Avoid direct contact with accessories during use.
- ⚠ Use only proper accessories designed for use with pneumatic screwdrivers, nutrunners, ratchets and pulse tools.

#### Projectile Hazards

- ⚠ Always wear impact-resistant eye protection when involved with or near the operation, repair or maintenance of the tool or changing accessories on the tool.
- ⚠ Be sure all others in the area are wearing impact-resistant eye protection.
- ⚠ Even small projectiles can injure eyes and cause blindness.
- ⚠ Do not use hand sockets as they can shatter. Use only power or impact sockets in good condition.
- ⚠ Always use the simplest hook-up possible. Long, springy extension bars and

## SAFETY INSTRUCTIONS

- ⚠ adapters absorb power and could break. Use deep sockets where possible.
- ⚠ Never operate the tool off of the work. It may run too fast and cause the accessory to be thrown off the tool.
- ⚠ Serious injury can result from over-torqued or under-torqued fasteners, which can break, or loosen and separate. Released assemblies can become projectiles. Assemblies requiring a specific torque must be checked using a torque meter.

Note: So-called "click" torque wrenches do not check for potentially dangerous over-torque conditions.

#### Workplace Hazards

- ⚠ Slip/Trip/Fall is a major cause of serious injury or death. Be aware of excess hose left on the walking or work surface.
- ⚠ Maintain a balanced body position and secure footing.
- ⚠ High sound levels can cause permanent hearing loss. Use hearing protection as recommended by your employer or OSHA regulation (see 29 CFR part 1910).
- ⚠ Repetitive work motions, awkward positions and exposure to vibration can be harmful to hands and arms. If numbness, tingling, pain or whitening of the skin occurs, stop using tool and consult a physician.
- ⚠ Always support the tool's handle securely, in the direction opposite of the spindle rotation, to reduce the effect of sudden torque reaction during final tightening and initial loosening.
- ⚠ An additional support handle or absorption bar may be needed to resist torque reaction. Absorption bars must be positioned correctly to avoid injury.
- ⚠ Proceed with care in unfamiliar surroundings. Be aware of potential hazards created by your work activity.
- ⚠ Some dust created by power sanding, sawing, grinding, drilling and other construction activities contains chemicals known to the State of California to cause cancer and birth defects or other reproductive harm. Some examples of these chemicals are:
  - Lead from lead based paints
  - Crystalline silica bricks and cement and other masonry products
  - And Arsenic and chromium from chemically-treated rubber
 Your risk from these exposures varies, depending on how often you do this type of work. To reduce your exposure to these chemicals: work in a well ventilated area, and work with approved safety equipment, such as dust masks that are specially designed to filter out microscopic particles.

#### Additional Safety Topics

- ⚠ The workpiece must be held securely.
- ⚠ This tool and its accessories must not be modified.
- ⚠ This tool is not insulated for coming into contact with electric power sources and is not recommended for use in explosive atmospheres.
- ⚠ Operators and maintenance personnel must be physically able to handle the bulk, weight and power of the tool and be capable of performing the job task.

# CP886/886H

## Air Ratchet

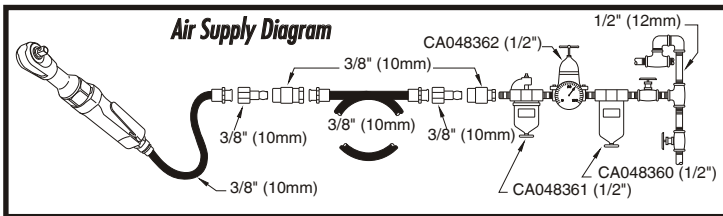
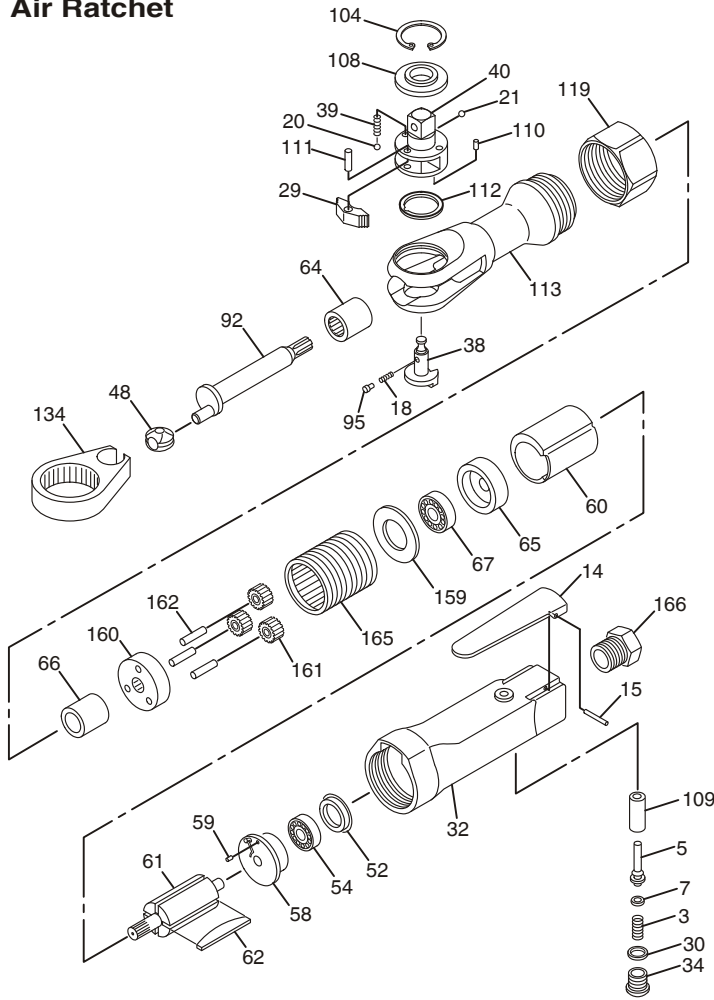

Index No.	Part No.	Description	No. Req'd.
3	CA146388	Spring-Throttle	1
5	CA146389	Valve-Throttle	1
7	CA146390	O-Ring	1
14	CA146391	Lever-Throttle	1
15	CA146392	Pin-Roll	1
18	CA146393	Spring-Ratchet	1
20	CA146394	Ball-Steel	2
21	CA146395	Ball-Steel (CP886)	1
	CA147671	Ball-Steel (CP886H)	1
29	CA146396	Pawl-Ratchet	1
30	CA146397	O-Ring	1
32	CA146398	Handle-Throttle (Incl: Index No. 109)	1
34	CA146399	Plug-Throttle Valve	1
38	CA146400	Button-Reverse (CP886)	1
	CA147670	Button-Reverse (CP886H)	1
39	CA146401	Spring-Friction	2
40	CA146402	Shank-Ratchet 3/8" (CP886)	1
	CA147667	Shank-Ratchet 1/2" (CP886H)	1
48	CA146403	Bushing-Drive	1
52	CA146404	Cap-End Plate	1
54	CA146405	Bearing-Ball	1
58	CA146407	Plate-Rear End	1
59	CA146408	Pin-Dowel	1
60	CA146409	Liner (Incl: Index No. 59)	1
61	CA146410	Rotor	1
62	CA146411	Blade-Rotor (Set of 4)	1
64	CA146412	Bearing-Needle	1
65	CA146413	Plate-Front End	1
66	CA146414	Bearing-Plain	1
67	CA146415	Bearing-Ball	1
92	CA146416	Shaft-Crank	1
95	CA146417	Pin-Lock	1
104	CA146418	Ring-Retaining	1
108	CA146419	Washer-Thrust (Incl: Index No. 110) (CP886)	1
	CA147672	Washer-Thrust (Incl: Index No. 110) (CP886H)	1
109	CA146420	Bushing-Throttle	1
110	CA146421	Pin-Roll	1
111	CA146422	Pin-Dowel	1
112	CA146423	Washer	1
113	CA146424	Housing-Ratchet (Incl: Index Nos. 64 & 66)	1
119	CA146425	Clamp-Housing	1
134	CA146426	Yoke-Ratchet	1
159	CA146427	Washer	1
160	CA146428	Spindle-Idler	1
161	CA146429	Gear-Idler	3
162	CA146430	Roller-Needle	3
165	CA146431	Housing-Spindle	1
166	CA146432	Bushing-Air Inlet	1
	CA133961	Cushion Cover (Not Shown)	1
	CA144007	Warning Decal (Not Shown)	1

### Tune-Up Kit

CA146437 (Incl: Index No's 3, 18, 20, 21, 30, 34, 39, 52, 62, 95, & 104)

### Ratchet Head Replacement Kit (CP886)

CA146436 (Incl: Index No's 18, 20, 21, 29, 38, 40, 95, 104, 108, 111 & 112)

### Ratchet Head Replacement Kit (CP886H)

CA147668 (Incl: Index No's 18, 20, 21, 29, 38, 40, 95, 104, 108, 111 & 112)