

**INSTRUCTION MANUAL**

**Air Supply Requirements**

1. Supply tool with 90 psig (6.2 bar) of clean, dry air. High pressure drastically reduces tool life.
2. Connect tool to air line using pipe, hose, and fitting sizes shown in the diagram on page 12.
3. Minimum compressor requirement: 1 hp (746 w), 20 gallon (76 l) air tank.

**Lubrication**

1. Use an air line lubricator with SAE #10 oil, adjusted to two (2) drops per minute. If an air line lubricator cannot be used, add air motor oil to the inlet once a day.
2. Monthly, lubricate the drive bushing and ratchet yoke with a good grade bearing grease. Periodically, depending upon use, the ratchet head assembly should be removed, cleaned and re-greased.

**Noise & Vibration Declaration\***

Sound pressure level 96.5 dB(A) in accordance with Pneuop PN8NTC1.2. For sound power, add 10 dB(A).

Vibration value 7.9 m/s<sup>2</sup>, re. ISO 8662-1.

**Maintenance**

1. Disassemble and inspect air motor every three (3) months if the tool is used every day. Replace damaged or worn parts.
2. High wear parts are underlined in the parts list.
3. To keep downtime to a minimum, the following service kits, detailed on page 12, are recommended: Tune-Up Kit CA155086, Ratchet Head Replacement Kit CA155084 (CP828), CA155085 (CP828H).

\*These declared values were obtained by laboratory type testing in compliance with the stated standards and are not adequate for use in risk assessments. Values measured in individual work places may be higher than the declared values. The actual exposure values and risk of harm experienced by an individual user are unique and depend upon the way the user works, the workplace and the workstation design, as well as upon the exposure time and the physical condition of the user. We, Chicago Pneumatic, cannot be held liable for the consequences of using the declared values, instead of values reflecting the actual exposure, in an individual risk assessment in a work place situation over which we have no control.

**EC DECLARATION OF CONFORMITY**

We, Chicago Pneumatic Tool Company, 1800 Overview Drive, Rock Hill, SC 29730 USA, declare under our sole responsibility that the product to which this declaration relates, is in conformity with the requirements of the Council Directive of June 1998 on the approximation of the laws of the Member States relating to machinery (98/37/EC).

**Machine Name** CP828 Series Air Ratchet

**Machine Type** Assembly Power Tool for Threaded Fasteners - No other use is permitted.

**Serial No.** Tools with No. 94200N or higher

**Technical Data**

3/8" (10 mm) and 1/2" (13 mm) Sq. Dr. Std.

Air pressure 90 psi (6.2 bar)

Torque range 10-50 ft.-lb. (13-70 Nm)

Ult. torque @ 90 psi (6.2 bar) 125 ft.-lb. (170 Nm)

**Harmonized Standards Applied** EN292

**National Standards Applied** ISO 8662-1, Pneuop 8N-1

**Name And Position Of Issuer** W.A. LeNeveu, President, Chicago Pneumatic Tool Company

**Signature Of Issuer** 

**Place And Date Of Issue** Utica, NY 13501 USA, July 31, 1994



**WARNING**

*To reduce risk of injury, everyone using, installing, repairing, maintaining, changing accessories on, or working near this tool must read and understand these instructions before performing any such task.*

The goal of Chicago Pneumatic is to produce tools that help you work safely and efficiently. The most important safety device for this or any tool is YOU. Your care and good judgment are the best protection against injury. All possible hazards cannot be covered here, but we have tried to highlight some of the important ones.

**Air Supply and Connection Hazards**

- ⚠ Air under pressure can cause severe injury.
- ⚠ Always shut off air supply, drain hose of air pressure and disconnect tool from air supply when not in use, before changing accessories or when making repairs.
- ⚠ Never direct air at yourself or anyone else.
- ⚠ Whipping hoses can cause serious injury. Always check for damaged or loose hoses and fittings.
- ⚠ Do not use quick disconnect couplings at tool. See instructions for correct set-up.
- ⚠ Whenever universal twist couplings are used, lock pins must be installed.
- ⚠ Do not exceed maximum air pressure of 90 psi/6.2 bar or as stated on tool nameplate.

**Entanglement Hazards**

- ⚠ Keep away from rotating drive.
- ⚠ Do not wear jewelry or loose clothing.
- ⚠ Choking can occur if neckwear is not kept away from the tool and accessories.
- ⚠ Scalping can occur if hair is not kept away from the tool and accessories.
- ⚠ Avoid direct contact with accessories during use.
- ⚠ Use only proper accessories designed for use with pneumatic screwdrivers, nutrunners, ratchets and pulse tools.

**Projectile Hazards**

- ⚠ Always wear impact-resistant eye protection when involved with or near the operation, repair or maintenance of the tool or changing accessories on the tool.
- ⚠ Be sure all others in the area are wearing impact-resistant eye protection.
- ⚠ Even small projectiles can injure eyes and cause blindness.
- ⚠ Do not use hand sockets as they can shatter. Use only power or impact sockets in good condition.
- ⚠ Always use the simplest hook-up possible. Long, springy extension bars and

SAFETY INSTRUCTIONS

- ⚠ adapters absorb power and could break. Use deep sockets where possible.
- ⚠ Never operate the tool off of the work. It may run too fast and cause the accessory to be thrown off the tool.
- ⚠ Serious injury can result from over-torqued or under-torqued fasteners, which can break, or loosen and separate. Released assemblies can become projectiles. Assemblies requiring a specific torque must be checked using a torque meter.

Note: So-called "click" torque wrenches do not check for potentially dangerous over-torque conditions.

**Workplace Hazards**

- ⚠ Slip/Trip/Fall is a major cause of serious injury or death. Be aware of excess hose left on the walking or work surface.
- ⚠ Maintain a balanced body position and secure footing.
- ⚠ High sound levels can cause permanent hearing loss. Use hearing protection as recommended by your employer or OSHA regulation (see 29 CFR part 1910).
- ⚠ Repetitive work motions, awkward positions and exposure to vibration can be harmful to hands and arms. If numbness, tingling, pain or whitening of the skin occurs, stop using tool and consult a physician.
- ⚠ Always support the tool's handle securely, in the direction opposite of the spindle rotation, to reduce the effect of sudden torque reaction during final tightening and initial loosening.
- ⚠ An additional support handle or absorption bar may be needed to resist torque reaction. Absorption bars must be positioned correctly to avoid injury.
- ⚠ Proceed with care in unfamiliar surroundings. Be aware of potential hazards created by your work activity.
- ⚠ Some dust created by power sanding, sawing, grinding, drilling and other construction activities contains chemicals known to the State of California to cause cancer and birth defects or other reproductive harm. Some examples of these chemicals are:
  - Lead from lead based paints
  - Crystalline silica bricks and cement and other masonry products
  - And Arsenic and chromium from chemically-treated rubber

Your risk from these exposures varies, depending on how often you do this type of work. To reduce your exposure to these chemicals: work in a well ventilated area, and work with approved safety equipment, such as dust masks that are specially designed to filter out microscopic particles.

**Additional Safety Topics**

- ⚠ The workpiece must be held securely.
- ⚠ This tool and its accessories must not be modified.
- ⚠ This tool is not insulated for coming into contact with electric power sources and is not recommended for use in explosive atmospheres.
- ⚠ Operators and maintenance personnel must be physically able to handle the bulk, weight and power of the tool and be capable of performing the job task.
- ⚠ For professional use only.

# CP828 Series Air Ratchet

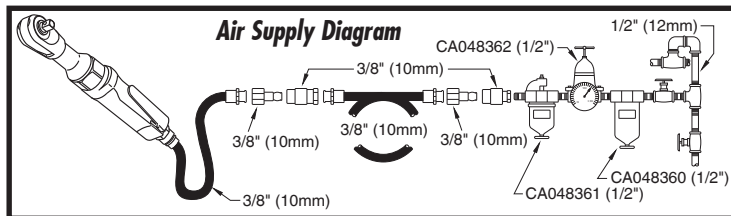
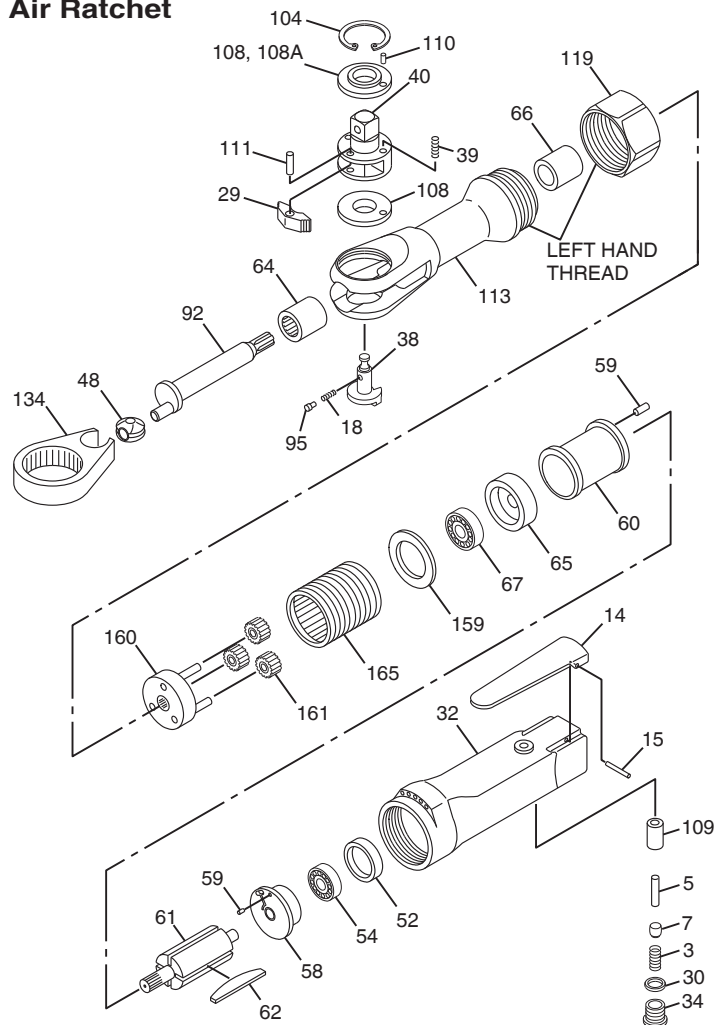

Index No.	Part No.	Description	No. Req'd.
3	KF124390	Spring-Throttle	1
5	KF124391	Stem-Valve	1
7	KF125190	Valve-Throttle	1
14	KF124393	Lever-Throttle	1
15	KF124394	Pin-Roll	1
18	KF124395	Spring-Ratchet	1
29	KF124397	Pawl-Ratchet	1
30	A082777	O-Ring-012	1
32	KF134172	Handle-Throttle (Incl: Index No. 109)	1
34	KF134162	Plug-Throttle Valve	1
38	CA147984	Button-Reverse (Model E)(Incl: Plug Grease CA147985)	1
39	CA154958	Spring-Friction (Model E)	3
40	CA154957	Shank-Ratchet (Model E)(CP828)	1
	CA155094	Shank-Ratchet (Model E)(CP828H)	1
48	KF124404	Bushing-Drive	1
52	KF125284	Disc-Plastic	1
54	S025101	Bearing-Ball	1
58	KF131001	Plate-Rear End	1
59	KF124410	Pin-Dowel	1
60	KF124411	Liner (Incl: Index No. 59)	1
61	KF134173	Rotor	1
62	KF138247	Blade-Rotor (Set of 4)	1
64	KF124500	Bearing-Needle	1
65	KF124415	Plate-Front End	1
66	KF134167	Bearing-Plain	1
67	C087834	Bearing-Ball	1
92	KF134165	Shaft-Crank	1
95	KF124418	Pin-Lock	1
104	C089956	Ring-Internal Retaining 1.25 dia.	1
108	KF140192	Washer-Thrust (Incl: Index No. 110) (1 Req'd. for CP828H)	2
108A	KF141030	Washer-Thrust (Incl: Index No. 110)(CP828H)	1
109	KF125409	Bushing-Throttle	1
110	KF140185	Pin-Dowel	2
111	KF124425	Pin-Dowel	1
113	KF140195	Housing Ratchet (Incl: Index Nos. 64 & 66)	1
119	KF124427	Clamp-Housing	1
134	KF124428	Yoke-Ratchet	1
159	KF124429	Washer	1
160	KF134168	Spindle-Idler	1
161	KF134170	Gear-Idler	3
165	KF134171	Housing-Spindle	1
	CA144813	Warning Label (Not Shown)	1

### Tune-Up Kit (Model E)

CA155086 (Incl: Index Nos. 3, 18, 30, 34, 39, 52, 62, 95, & 104)

### Ratchet Head Replacement Kit (Model E)

CA155084 (CP828), CA155085 (CP828H)(Incl: Index Nos. 18, 29, 38, 39, 40, 95, 104, 108, 108A, & 111)