

INSTRUCTION MANUAL

Air Supply Requirements

1. Supply tool with 90 psig (6.2 bar) of clean, dry air. Higher pressure drastically reduces tool life.
2. Connect tool to air line using pipe, hose, and fitting sizes shown in the diagram on page 12.

Lubrication

1. Use an air line lubricator with SAE #10 oil, adjusted to two (2) drops per minute. If an air line lubricator cannot be used, add air motor oil to the inlet once a day.
2. Monthly, lubricate the drive bushing and ratchet yoke with a good grade bearing grease. Periodically, depending upon use, the ratchet head assembly should be removed, cleaned and re-greased.

Noise & Vibration Declaration*

Sound pressure level 90.5 dB(A) in accordance with Pneuop PN8NTC1.2. For sound power, add 10 dB(A).
Vibration value 6.1 m/s², re. ISO 8662-1.

Maintenance

1. Disassemble and inspect air motor every three (3) months if the tool is used every day. Replace damaged or worn parts. High wear parts are underlined in the parts list.
2. To keep downtime to a minimum, the following service kits, detailed on page 12, are recommended: CA155033 Tune-Up Kit, CA155034 Ratchet Head Replacement Kit (CP826), CA155035 Ratchet Head Replacement Kit (CP826T)

*These declared values were obtained by laboratory type testing in compliance with the stated standards and are not adequate for use in risk assessments. Values measured in individual work places may be higher than the declared values. The actual exposure values and risk of harm experienced by an individual user are unique and depend upon the way the user works, the workpiece and the workstation design, as well as upon the exposure time and the physical condition of the user. We, Chicago Pneumatic, cannot be held liable for the consequences of using the declared values, instead of values reflecting the actual exposure, in an individual risk assessment in a work place situation over which we have no control.



WARNING

To reduce risk of injury, everyone using, installing, repairing, maintaining, changing accessories on, or working near this tool must read and understand these instructions before performing any such task.

The goal of Chicago Pneumatic is to produce tools that help you work safely and efficiently. The most important safety device for this or any tool is YOU. Your care and good judgment are the best protection against injury. All possible hazards cannot be covered here, but we have tried to highlight some of the important ones.

Air Supply and Connection Hazards

- ⚠ Air under pressure can cause severe injury.
- ⚠ Always shut off air supply, drain hose of air pressure and disconnect tool from air supply when not in use, before changing accessories or when making repairs.
- ⚠ Never direct air at yourself or anyone else.
- ⚠ Whipping hoses can cause serious injury. Always check for damaged or loose hoses and fittings.
- ⚠ Do not use quick disconnect couplings at tool. See instructions for correct set-up.
- ⚠ Whenever universal twist couplings are used, lock pins must be installed.
- ⚠ Do not exceed maximum air pressure of 90 psi/6.2 bar or as stated on tool nameplate.

Entanglement Hazards

- ⚠ Keep away from rotating drive.
- ⚠ Do not wear jewelry or loose clothing.
- ⚠ Choking can occur if neckwear is not kept away from the tool and accessories.
- ⚠ Scalping can occur if hair is not kept away from the tool and accessories.
- ⚠ Avoid direct contact with accessories during use.
- ⚠ Use only proper accessories designed for use with pneumatic screwdrivers, nutrunners, ratchets and pulse tools.

Projectile Hazards

- ⚠ Always wear impact-resistant eye protection when involved with or near the operation, repair or maintenance of the tool or changing accessories on the tool.
- ⚠ Be sure all others in the area are wearing impact-resistant eye protection.
- ⚠ Even small projectiles can injure eyes and cause blindness.
- ⚠ Do not use hand sockets as they can shatter. Use only power or impact sockets in good condition.
- ⚠ Always use the simplest hook-up possible. Long, springy extension bars and

EC DECLARATION OF CONFORMITY

We, Chicago Pneumatic Tool Company, 1800 Overview Drive, Rock Hill, SC 29730 USA, declare under our sole responsibility that the product to which this declaration relates, is in conformity with the requirements of the Council Directive of June 1989 on the approximation of the laws of the Member States relating to machinery (89/392/EEC).

Machine Name CP826 Series Air Ratchet

Machine Type Assembly Power Tool for Threaded Fasteners-No other use is permitted.

Serial No. Tools with No. 97213A or higher

Technical Data

1/4" and 3/8" Sq. Dr. opt.

Air pressure 90 psi (6.2 bar)

Torque range 5-15 ft.-lb. (6-21 Nm)

Ult. torque 30 ft.-lb. (40 Nm)

Harmonized Standards Applied EN292

National Standards Applied ISO 8662-1, Pneuop PN8NTC1.2

Name And Position Of Issuer W.A. LeNeveu, President, Chicago Pneumatic Tool Company

Signature Of Issuer 

Place And Date Of Issue Rock Hill, SC 29730 USA, August 1, 1997

SAFETY INSTRUCTIONS

- ⚠ adapters absorb power and could break. Use deep sockets where possible.
- ⚠ Never operate the tool off of the work. It may run too fast and cause the accessory to be thrown off the tool.
- ⚠ Serious injury can result from over-torqued or under-torqued fasteners, which can break, or loosen and separate. Released assemblies can become projectiles. Assemblies requiring a specific torque must be checked using a torque meter.

Note: So-called "click" torque wrenches do not check for potentially dangerous over-torque conditions.

Workplace Hazards

- ⚠ Slip/Trip/Fall is a major cause of serious injury or death. Be aware of excess hose left on the walking or work surface.
- ⚠ Maintain a balanced body position and secure footing.
- ⚠ High sound levels can cause permanent hearing loss. Use hearing protection as recommended by your employer or OSHA regulation (see 29 CFR part 1910).
- ⚠ Repetitive work motions, awkward positions and exposure to vibration can be harmful to hands and arms. If numbness, tingling, pain or whitening of the skin occurs, stop using tool and consult a physician.
- ⚠ Always support the tool's handle securely, in the direction opposite of the spindle rotation, to reduce the effect of sudden torque reaction during final tightening and initial loosening.
- ⚠ An additional support handle or absorption bar may be needed to resist torque reaction. Absorption bars must be positioned correctly to avoid injury.
- ⚠ Proceed with care in unfamiliar surroundings. Be aware of potential hazards created by your work activity.
- ⚠ Some dust created by power sanding, sawing, grinding, drilling and other construction activities contains chemicals known to the State of California to cause cancer and birth defects or other reproductive harm. Some examples of these chemicals are:
 - Lead from lead based paints
 - Crystalline silica bricks and cement and other masonry products
 - And Arsenic and chromium from chemically-treated rubber
 Your risk from these exposures varies, depending on how often you do this type of work. To reduce your exposure to these chemicals: work in a well ventilated area, and work with approved safety equipment, such as dust masks that are specially designed to filter out microscopic particles.

Additional Safety Topics

- ⚠ The workpiece must be held securely.
- ⚠ This tool and its accessories must not be modified.
- ⚠ This tool is not insulated for coming into contact with electric power sources and is not recommended for use in explosive atmospheres.
- ⚠ Operators and maintenance personnel must be physically able to handle the bulk, weight and power of the tool and be capable of performing the job task.

CP826 Series Air Ratchet

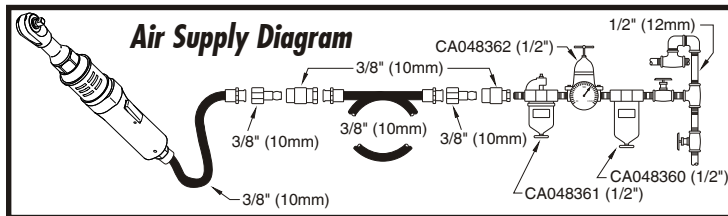
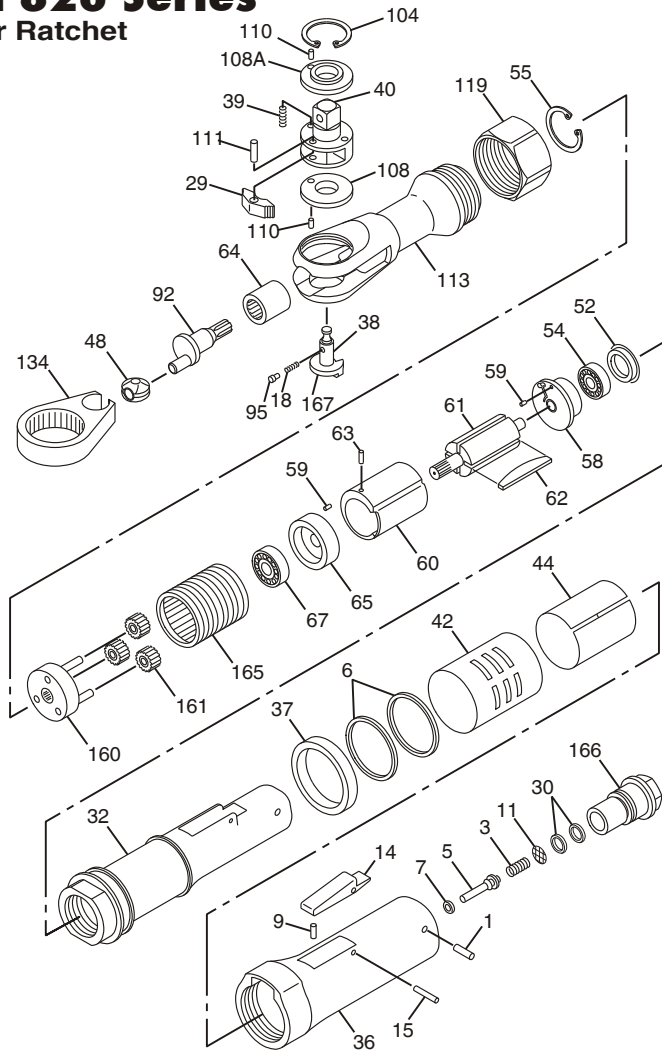

Index No.	Part No.	Description	No. Req'd.
1	CA155013	Pin-Dowel	1
3	CA155014	Spring-Throttle	1
5	CA155010	Valve-Throttle	1
6	CA154998	O-Ring	2
7	CA155009	Seat-Valve	1
9	CA155017	Pin-Dowel	1
11	CA155012	Screen-Air	1
14	CA155016	Trigger	1
15	CA155015	Pin-Roll	1
18	KF138212	Spring-Ratchet	1
29	KF138195	Pawl-Ratchet	1
30	C136939	O-Ring	2
32	CA155018	Housing-Motor	1
36	CA155006	Cover-Housing (Black)	1
	CA155008	Cover-Housing (Orange)	1
	CA155007	Cover-Housing (Green)	1
37	CA154995	Ring-Trim (Black)	1
	CA154997	Ring-Trim (Orange)	1
	CA154996	Ring-Trim (Green)	1
38	CA154994	Button-Reverse	1
39	CA149686	Spring-Compression	2
40	CA149701	Shank-Ratchet (CP826, CP826G, CP826O)	1
	CA149687	Shank-Ratchet (CP826T)	1
42	CA155000	Deflector-Exhaust (CP826, CP826G, CP826O)	1
	CA155001	Deflector-Exhaust (CP826T)	1
44	CA154999	Screen-Exhaust	1
48	KF138186	Bushing-Drive	1
52	CA155005	Cap-Bearing	2
54	CA155004	Bearing	1
55	KF138179	Ring-Retaining	1
58	CA155003	Plate-Rear End	1
59	KF138196	Pin-Roll	2
60	KF138199	Liner	1
61	CA155002	Rotor	1
62	KF138202	Set-Rotor Blade (4)	1
63	KF124410	Pin-Dowel	1
64	KF138213	Bearing-Needle	1
65	KF138201	Plate-Front End	1
67	C087834	Bearing-Ball	1
92	KF138177	Shaft-Crank	1
95	KF138187	Pin-Lock	1
104	KF138191	Ring-Internal	1
108	KF141564	Washer-Thrust (1 Req'd. for CP826, CP826G, CP826O)	1
108A	KF141853	Washer-Thrust (CP826T)	1
110	KF140185	Pin-Dowel (Incl. with Index No. 108 & 108A)	2
111	KF138211	Pin-Ratchet	1
113	KF141563	Housing-Ratchet (Incl. Index No. 64)	1
119	KF138174	Clamp-Housing	1
134	KF138206	Yoke-Ratchet	1
160	KF138203	Spindle-Idler	1
161	KF138205	Gear-Idler (13T)	3
165	KF138204	Housing-Spindle	1
166	CA155011	Bushing-Air Inlet	1
	CA155262	Decal-Safety Warning (Not Shown)	1
	CA154993	Cover-Head (Not Shown)	1
	CA131376	Decal-Oil Daily	1
167	CA147985	Fitting-Grease (Not Shown)	1

Ratchet Head Replacement Kit
CA155034 (CP826) CA155035 (CP826T) (Incl: Index Nos. 18, 29, 38, 39, 40, 95, 104, 108, 108A & 111)

Tune-Up Kit
CA155033 (Incl: Index Nos. 3, 6, 18, 30, 39, 52, 62, 95 & 104)