

INSTRUCTION MANUAL

Air Supply Requirements

1. Supply tool with 90 psig (6.2 bar) of clean, dry air. Higher pressure drastically reduces tool life.
2. Connect tool to air line using pipe, hose and fitting sizes shown in the diagram on page 12.

Lubrication

Use an air line lubricator with SAE #10 oil, adjusted to two drops per minute. If an air line lubricator cannot be used, add air motor oil to the inlet once a day.

Noise & Vibration Declaration*

Sound pressure level 87 dB(A) in accordance with Pneuop 8N-1. For sound power, add 10 dB(A).
Vibration value 4.0 m/s², re. ISO 8662-1.

Maintenance

1. Disassemble and inspect parts every three months if the tool is used every day. Replace damaged or worn parts.
2. High wear parts are underlined in the parts list.

*These declared values were obtained by laboratory type testing in compliance with the stated standards and are not adequate for use in risk assessments. Values measured in individual work places may be higher than the declared values. The actual exposure values and risk of harm experienced by an individual user are unique and depend upon the way the user works, the workpiece and the workstation design, as well as upon the exposure time and the physical condition of the user. We, Chicago Pneumatic, cannot be held liable for the consequences of using the declared values, instead of values reflecting the actual exposure, in an individual risk assessment in a work place situation over which we have no control.



The goal of Chicago Pneumatic is to produce tools that help you work safely and efficiently. The most important safety device for this or any tool is YOU. Your care and good judgment are the best protection against injury. All possible hazards cannot be covered here, but we have tried to highlight some of the important ones.

For Additional Safety Information Consult:

- ▲ Your employer, union and/or trade association.
- ▲ US Department of Labor (OSHA);
- ▲ "Safety Code for Portable Air Tools" (ANSI B186.1)
- ▲ "Safety Requirements for Hand-Held Non-Electric Power Tools"

Air Supply and Connection Hazards

- ▲ Air under pressure can cause severe injury.
- ▲ Always shut off air supply, drain hose of air pressure and disconnect tool from air supply when not in use, before changing accessories or when making repairs.
- ▲ Never direct air at yourself or anyone else.
- ▲ Whipping hoses can cause serious injury. Always check for damaged or loose hoses and fittings.
- ▲ Do not use quick disconnect couplings at tool. See instructions for correct set-up.
- ▲ Whenever universal twist couplings are used, lock pins must be installed.
- ▲ Do not exceed maximum air pressure of 90 psi/6.2 bar or as stated on tool nameplate.

Projectile Hazards

- ▲ Always wear impact-resistant eye and face protection when involved with or near the operation, repair or maintenance of the tool or changing accessories on the tool.
- ▲ Be sure all others in the area are wearing impact-resistant eye and face protection.
- ▲ Even small projectiles can injure eyes and cause blindness.

Operating Hazards

- ▲ Always shut off air supply, relieve hose of air pressure and disconnect tool from air supply when changing accessories.
- ▲ Cutting with these tools will create sharp edges. Wear gloves to protect hands.

SAFETY INSTRUCTIONS

- ▲ Avoid direct contact with accessory and work surface during and after work.
- ▲ Cutting edges and saw blades can become hot during use. Do not touch.
- ▲ Never force the tool to cut faster or through heavier gauge material than rated capacity.
- ▲ To prevent damage to the tool and accessory, accessory must be held firmly against work surface while cutting.

Workplace Hazards

- ▲ Slip/Trip/Fall is a major cause of serious injury or death. Be aware of excess hose left on the walking or work surface.
- ▲ High sound levels can cause permanent hearing loss. Use hearing protection as recommended by your employer or OSHA regulation (see 29 CFR part 1910).
- ▲ Maintain a balanced body position and secure footing.
- ▲ Repetitive work motions, awkward positions and exposure to vibration can be harmful to hands and arms. If numbness, tingling, pain or whitening of the skin occurs, stop using tool and consult a physician.
- ▲ Avoid inhaling dust or handling debris from the work process which can be harmful to your health. Use dust extraction and wear respiratory protective equipment when working with materials which produce airborne particles.
- ▲ Proceed with care in unfamiliar surroundings. Be aware of potential hazards created by your work activity.
- ▲ Some dust created by power sanding, sawing, grinding, drilling and other construction activities contains chemicals known to the State of California to cause cancer and birth defects or other reproductive harm. Some examples of these chemicals are:
 - Lead from lead based paints
 - Crystalline silica bricks and cement and other masonry products
 - And Arsenic and chromium from chemically-treated rubber

Your risk from these exposures varies, depending on how often you do this type of work. To reduce your exposure to these chemicals: work in a well ventilated area, and work with approved safety equipment, such as dust masks that are specially designed to filter out microscopic particles.

Additional Safety Topics

- ▲ This tool and its accessories must not be modified.
- ▲ This tool is not intended for use in an explosive atmosphere and is not insulated for contact with electric power sources.
- ▲ Operators and maintenance personnel must be capable of handling the power of the tool and performing the job task.
- ▲ For professional use only

CP785S Shear

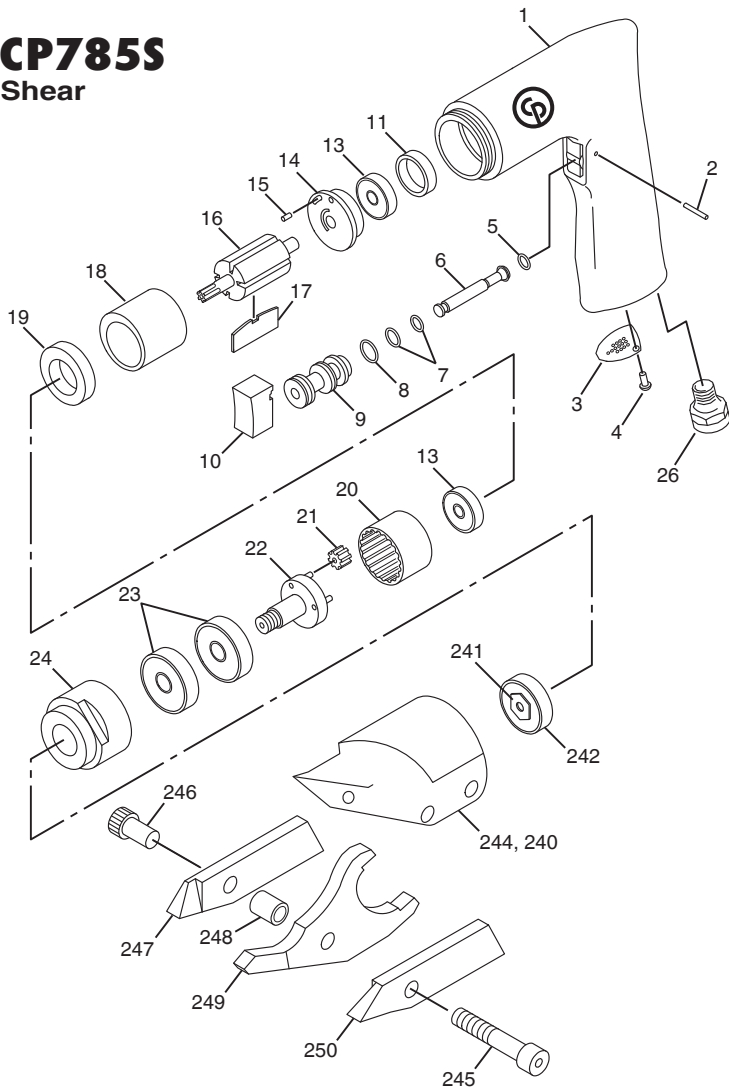

Index No.	Part No.	Description	No. Req'd.
1	KF140129	Housing- Motor	1
2	KF140131	Pin	1
3	KF140132	Deflector-Exhaust	1
4	KF140133	Screw	1
5	KF125427	O-Ring-Throttle	1
6	KF140134	Stem-Valve	1
7	KF125295	O-Ring	2
8	CA083354	O-Ring-111	1
9	KF140143	Bushing-Valve	1
10	KF140135	Trigger	1
11	KF125284	Disc-Plastic	1
13	S025101	Bearing-Ball	2
14	CA148597	Plate-Rear End	1
15	KF124410	Pin-Dowel	1
16	KF140136	Rotor	1
17	KF138247	Blade-Set (4)	1
18	KF140148	Cylinder	1
19	KF140137	Plate-Front End	1
20	KF137282	Gear-Internal	1
21	KF140138	Gear-Idler	3
22	KF140139	Spindle	1
23	S014490	Bearing-Ball	2
24	KF140144	Nut-Clamp	1
26	CA091545	Bushing-Air Inlet	1
240	KF137228	Shear Head Assembly	1
241	KF139554	Nut-Eccentric	1
242	S083790	Bearing-Ball	1
244	KF139556	Housing-Cutter	1
245	KF124298	Screw-Lock	3
246	KF139558	Nut-Lock	3
247	KF139559	Blade-Left	1
248	KF139560	Spacer	2
249	KF139751	Blade-Center	1
250	KF139752	Blade-Right	1
	CA146619	Decal-Safety Warning (Not Shown)	1

