

INSTRUCTION MANUAL

Air Supply Requirements

1. Supply tool with 90 psig (6.2 bar) of clean, dry air. Higher pressure drastically reduces tool life.
2. Connect tool to air line using pipe, hose and fitting sizes shown in the diagram on page 12.

Lubrication

Use an air line lubricator with SAE #10 oil, adjusted to two drops per minute. If an air line lubricator cannot be used, add air motor oil to the inlet once a day.

Noise & Vibration Declaration*

Sound pressure level 90 dB(A) in accordance with Pneuop PN8NTC1.2. For sound power, add 10 dB(A). (CP785)
 Vibration value <2.5 m/s², re. ISO 8662-1. (CP785)
 Sound pressure level 96.3 dB(A) in accordance with Pneuop PN8NTC1.2. For sound power, add 10 dB(A). (CP785H)
 Vibration value <2.5 m/s², re. ISO 8662-1. (CP785H)

Maintenance

1. Disassemble and inspect air motor every three months if the tool is used every day. Replace damaged or worn parts.
2. High wear parts are underlined in the parts list.

*These declared values were obtained by laboratory type testing in compliance with the stated standards and are not adequate for use in risk assessments. Values measured in individual work places may be higher than the declared values. The actual exposure values and risk of harm experienced by an individual user are unique and depend upon the way the user works, the workpiece and the workstation design, as well as upon the exposure time and the physical condition of the user. We, Chicago Pneumatic, cannot be held liable for the consequences of using the declared values, instead of values reflecting the actual exposure, in an individual risk assessment in a work place situation over which we have no control.

EC DECLARATION OF CONFORMITY

We, Chicago Pneumatic Tool Company, 1800 Overview Drive, Rock Hill, SC 29730 USA, declare under our sole responsibility that the product to which this declaration relates, is in conformity with the requirements of the Council Directive of June 1989 on the approximation of the laws of the Member States relating to machinery (89/392/EEC).

Machine Name CP785 Series 3/8 & 1/2 Inch Air Drill

Machine Type Power tool equipped with 3/8 in. (9 mm) and 1/2 in. (13 mm) drill chuck for use with various drill bits for drilling holes - No other use is permitted.

Serial No. Tools with No. 94200L or higher (CP785), 94200A or higher (CP785H) **Technical Data**

3/8 in. (9 mm) drill chuck (CP785)

1/2 in. (13 mm) drill chuck (CP785H)

Free speed 2400 RPM (CP785)

Free speed 500 RPM (CP785H)

Air pressure 90 psi (6.2 bar)

Harmonized Standards Applied EN292

National Standards Applied ISO 8662-1, Pneuop PN8NTC1.2

Name and Position of Issuer W. A. LeNeveu, President, Chicago Pneumatic Tool Company

Signature of Issuer 

Place and Date of Issue Utica, NY 13501 USA, July 31, 1994



WARNING

To reduce risk of injury, everyone using, installing, repairing, maintaining, changing accessories on, or working near this tool must read and understand these instructions before performing any such task.

The goal of Chicago Pneumatic is to produce tools that help you work safely and efficiently. The most important safety device for this or any tool is YOU. Your care and good judgment are the best protection against injury. All possible hazards cannot be covered here, but we have tried to highlight some of the important ones.

Air Supply And Connection Hazards

- ⚠ Air under pressure can cause severe injury.
- ⚠ Always shut off air supply, drain hose of air pressure and disconnect tool from air supply when not in use, before changing accessories or when making repairs.
- ⚠ Never direct air at yourself or anyone else.
- ⚠ Whipping hoses can cause serious injury. Always check for damaged or loose hoses and fittings.
- ⚠ Do not use quick disconnect couplings at tool. See instructions for correct setup.
- ⚠ Whenever universal twist couplings are used, lock pins must be installed.
- ⚠ Do not exceed maximum air pressure of 90 psi/6.2 bar or as stated on tool nameplate.

Projectile Hazards

- ⚠ Always wear impact-resistant eye and face protection when involved with or near the operation, repair or maintenance of the tool or changing accessories on the tool.
- ⚠ Be sure all others in the area are wearing impact-resistant eye and face protection.
- ⚠ Even small projectiles can injure eyes and cause blindness.

Entanglement Hazards

- ⚠ Keep away from rotating bit and chuck.
- ⚠ Do not wear jewelry or loose clothing.
- ⚠ You can be cut or burned if you come in contact with the drill bit, chips or work surface.
- ⚠ Use intermittent drill pressure to avoid long shaved chips.

SAFETY INSTRUCTIONS

- ⚠ Scalping can occur if hair is not kept away from tool and accessories.
- ⚠ Choking can occur if neckwear is not kept away from tool and accessories.

Bit Binding Hazards

- ⚠ The drill bit can suddenly bind and cause the work piece or tool to rotate, causing arm and shoulder injuries.
- ⚠ Enough torque is generated to cause falls.
- ⚠ Always use sharp bits.
- ⚠ Reduce downward pressure at breakthrough.
- ⚠ ANSI recommends the use of a support handle on drills with a chuck capacity larger than 3/8 in. or 10 mm.
- ⚠ Operators and maintenance personnel must be physically able to handle the bulk, weight and power of this tool.

Workplace Hazards

- ⚠ Slip/Trip/Fall is a major cause of serious injury or death. Be aware of excess hoses left on the walking or work surface.
- ⚠ Maintain a balanced body position and secure footing.
- ⚠ High sound levels can cause permanent hearing loss. Use hearing protection as recommended by your employer or OSHA regulation (see 29 CFR part 1910).
- ⚠ Repetitive work motions, awkward positions and exposure to vibration can be harmful to hands and arms. If numbness, tingling, pain or whitening of the skin occurs, stop using tool and consult a physician.
- ⚠ Avoid inhaling dust or handling debris from the work process which can be harmful to your health. Use dust extraction and wear respiratory protective equipment when working with materials which produce airborne particles.
- ⚠ Proceed with care in unfamiliar surroundings. Hidden hazards may exist, such as drilling into electric or other utility lines.
- ⚠ This tool is not intended for use in an explosive atmosphere and is not insulated for contact with electric power sources.
- ⚠ Some dust created by power sanding, sawing, grinding, drilling and other construction activities contains chemicals known to the State of California to cause cancer and birth defects or other reproductive harm. Some examples of these chemicals are:
 - Lead from lead based paints
 - Crystalline silica bricks and cement and other masonry products
 - And Arsenic and chromium from chemically-treated rubber
 Your risk from these exposures varies, depending on how often you do this type of work. To reduce your exposure to these chemicals: work in a well ventilated area, and work with approved safety equipment, such as dust masks that are specially designed to filter out microscopic particles.
- ⚠ For professional use only.

CP785 Series

Air Drill

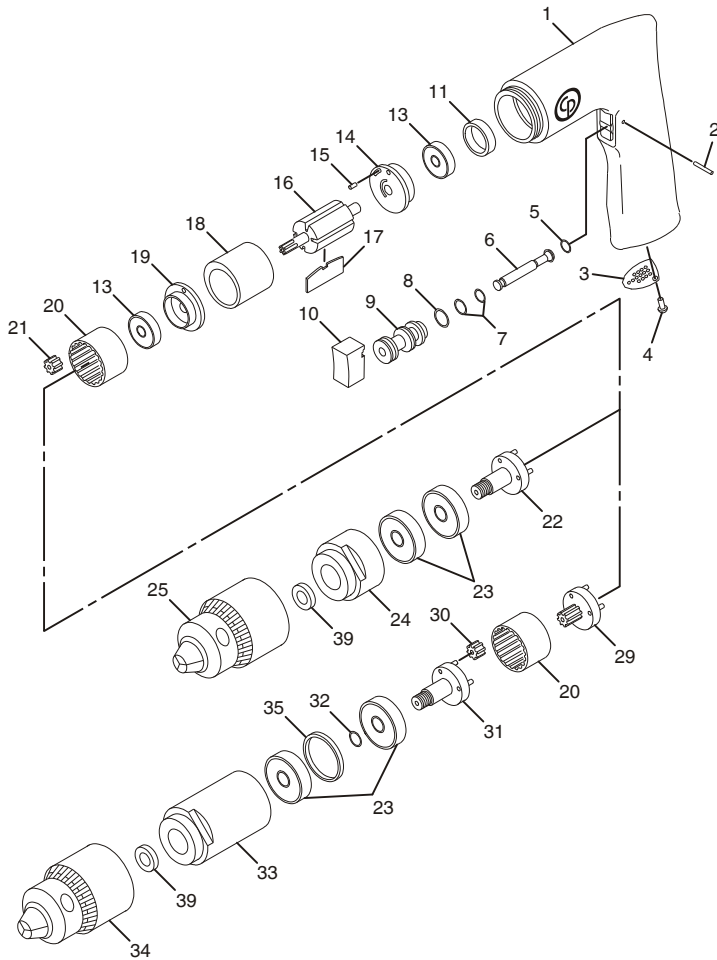

Index No.	Part No.	Description	No. Req'd.
1	KF140129	Motor Housing	1
2	KF140131	Pin	1
3	KF140132	Deflector-Exhaust	1
4	KF140133	Screw	1
5	KF125427	O-Ring	1
6	KF140134	Stem-Valve	1
7	KF125295	O-Ring	2
8	CA083354	O-Ring-111	1
9	KF140143	Bushing-Valve	1
10	KF140135	Trigger	1
11	KF125284	Disc-Plastic	1
13	S025101	Bearing-Ball	2
14	CA148597	Plate-Rear End	1
15	KF124410	Pin-Dowel	1
16	KF140136	Rotor	1
17	KF138247	Blade Set-Rotor (4)	1
18	KF140148	Cylinder	1
19	KF140137	Plate-Upper End	1
20	KF137282	Gear-Internal	2
21	KF140138	Gear-Idler	3
22	KF140139	Spindle	1
23	S014490	Bearing-Ball	2
24	KF140144	Nut-Clamp	1
25	KF124595	Chuck w/Key (Incl: C121582)	1
	CA146490	Chuck-Keyless (785 Metric only) (Not shown)	1
29	CA146171*	Spindle-1st Reduction	1
30	CA146172*	Gear-Idler	3
31	CA146173*	Spindle-2nd Reduction	1
32	CA146174*	Spacer	1
33	CA146175*	Nut-Clamp	1
34	CA146176*	Chuck-Drill w/Key (Incl: CA050122) Chuck-Keyless (785 Metric only) (Not shown)	1
35	CA146177*	Spacer	1
36	C136901*	Support Handle (Not Shown)	1
37	CA146179*	Handle-Bracket (Not Shown)	1
38	CA146619	Label-Warning (Not Shown)	1
39	CA146088	Spacer	1

*CP785H only

