





Chicago Pneumatic

Torque Wrenches



Model :	Square drive	Torque Range	Lenght	Precision
				%
CP8905	1/4'	5 – 25 Nm 50 – 250 in-lb	245 mm	± 4%
CP8910	3/8'	20 - 100 Nm 15 – 75 ft-lb	410 mm	± 4%
CP8915	1/2'	40 – 200 Nm 30 – 150 ft-lb	520 mm	± 4%
CP8917	1/2'	60 – 340 Nm 50 – 250 ft-lb	610 mm	± 4%
CP8920	3/4'	150 – 750 Nm 100 – 550 ft-lb	1060 mm	± 4%
CP8925	1'	200 – 1000Nm 150 – 750 ft-lb	1255 mm	± 4%

1. Unlock



2. Adjust



3. Align



4. Lock



CERTIFICATE OF CONFORMANCE IN ACCORDANCE WITH ISO6789-1

Model N° : Max. Derivation / Tolerance :

Serial N° : Units :

Range: 20 – 100Nm (The lowest value for torque certificate of conformance is from 20% of the maximum torque value.)

Ambient Temperature: Humidity: Inspector:

Set torque	Permissible		Test Results – CW (% Deviation)				
	Min.	Max.	1	2	3	4	5
20%							
60%							
100%							

Accessories fitted to the Torque Wrench for the purposes of this test:

Dimensions:

The limits shown, and the test equipment used for this Declaration of conformance, comply with the requirements of ISO 6789 – 1 : 2017

The Test results shown above, fall within the maximum permitted deviation – YES / NO

Measurement device used :

Model N° : Serial N° :

The measurement device used to conduct this test has been calibrated by :

To meet ISO 17025: 2005 traceability requirement.

The measurement error of this equipment is less than 25% of the maximum permissible deviation.

This calibration is valid for 12 months from stock despatch date.

Stock Despatch date : Place of issue :

Signature.....

Date of test :

Quality Manager : Signature :

1. When it is not used, be sure to set torque to the lowest value.
2. Do not keep applying pressure after reaching the present torque; otherwise, the work piece may get damaged.
3. Before setting the torque value, check to see if the torque wrench is at lock or unlock status
4. Do not use an extension on the handle. This would impair the set value being correctly signalled
5. Never set the torque above or below the limit of the scale!
6. Handle your torque wrench as carefully as you treat a measurement instrument!



**Chicago
Pneumatic**



CP89 Series

CP Torque Wrenches

Complete range
 $1/4'' - 3/8'' - 1/2'' - 3/4'' - 1''$



- ✓ **Accurate**
- ✓ **Durable**
- ✓ **Ergonomic**

**Vehicle
Service**Tools

People. Passion. Performance.

CP89 Series CP Torque Wrenches

Accuracy & durability

- 4% according to the EN ISO 6789:2003 specifications
- Long-lasting accuracy up to 25000 cycles

COMPLETE RANGE

1/4" - 3/8" - 1/2" - 3/4" - 1"



COMPACT

To work in restricted areas

ACCURACY

- 4% according to the EN ISO 6789:2003 specifications
- Long-lasting accuracy up to 25000 cycles

ROBUST

54 teeth fixed pear head ratchet with quick socket release

DURABLE

Reliability of the mechanism up to 25000 cycles

COMFORT

Aluminum handle resistant to common chemicals in workshops

EASY & PRECISE ADJUSTMENT

- Torque adjustment with manual locking in front of the handle
- Fine scale graduation

TORQUE WRENCHES IN FOOT-POUNDS

Model	Part #	Square Drive	Torque	Tool Length	Tool Weight	Weight with the Box
		in.	ft.-lbs.	in.	lbs	lbs
CP8905	894 108 9055	1/4"	50 – 250 in.-lbs.	9.64	2.82	3.19
CP8910	894 108 9105	3/8"	15 – 75	16.14	3.30	3.68
CP8915	894 108 9155	1/2"	30 – 150	20.47	4.45	4.80
CP8920	894 108 9205	3/4"	100 – 550	41.73	35.71	37.47
CP8925	894 108 9255	1"	100 – 750	49.40	35.71	37.47

TORQUE WRENCHES IN NEWTON METERS

Model	Part #	Square Drive	Torque	Tool Length	Tool Weight	Weight with the Box
		in.	Nm	mm	kg	kg
CP8905	894 108 9050	1/4"	5 – 25	245	1,28	1,45
CP8910	894 108 9100	3/8"	20 – 100	410	1,5	1,67
CP8915	894 108 9150	1/2"	40 – 200	520	2,02	2,18
CP8920	894 108 9200	3/4"	150 – 750	1060	16,2	17
CP8925	894 108 9250	1"	200 – 1000	1255	16,2	17

ADDITIONAL FEATURES

- Sensitive and sound signals when reaches the torque
- Provided with ISO 6789 calibration certificate
- Provided in a protective blow molded case
- Numbered wrenches

Applications

- General mechanics on light and heavy vehicles
- Tire changing operations on light and heavy vehicles
- Industrial maintenance and repair



Over 110 years of experience

Since 1901 the Chicago Pneumatic (CP) name has represented reliability and attention to customer needs, with construction, maintenance and production tools and compressors designed for specific industrial applications. Today, CP has a global reach, with local distributors around the world.

Our people start every single day with a passion to research, develop, manufacture and deliver new products that are meant to meet your needs not only today, but tomorrow as well.

SPARE PARTS

MODEL	SQUARE DRIVE	HEAD REPAIR KIT
CP8905	1/4"	894 017 1921
CP8910	3/8"	894 017 1922
CP8915	1/2"	894017 1923
CP8920	3/4"	894 017 1924
CP8925	1"	894 017 1925

OPERATOR ACCESSORIES

PART#	DESCRIPTION
Gloves	
894 017 1574	Impact glove size medium
894 015 8618	Impact glove size large
894 015 8619	Impact glove size X-large
894 017 1573	Impact glove size XX-large



1/2" DRIVE IMPACT SOCKET SETS

PART#	MODEL	DESCRIPTION [SIZES]
894 016 4465	SS4013D	13PC - Deep SAE set [7/16, 1/2, 9/16, 5/8, 11/16, 3/4, 13/16, 7/8, 15/16, 1, 1-1/16, 1-1/8, 1-3/16, 1-1/4 in.]
894 016 4458	SS4114D	14PC - Deep Metric set [10, 11, 12, 13, 14, 15, 16, 17, 18, 19, 21, 22, 26, 27 mm]
Thin wall		
894 016 4464	SS413WP	3PC - Deep thin wall wheel protector set [17, 19, 21 mm]
894 016 4458	SS4114D	3PC - Deep thin wall set [17, 19, 21 mm]



Impact sockets are laser etched for easy identification. Sets are supplied in a sturdy blow mold case.

1" DRIVE IMPACT SOCKET SETS

PART#	MODEL	DESCRIPTION [SIZES]
894 016 4478	SS808	8PC - Standard SAE set [7/8", 15/16", 1", 1-1/16", 1-1/8", 1-3/16", 1-1/4", 1-1/2"]
894 016 4479	SS808D	8PC - Deep SAE set [7/8", 15/16", 1", 1-1/16", 1-1/8", 1-3/16", 1-1/4", 1-1/2"]
8940164476	SS818	8PC - Standard Metric set [27, 30, 32, 33, 35, 36, 38, 41 mm]
8940166017	SS818D	8PC - Deep Metric set [27, 30, 32, 33, 35, 36, 38, 41 mm]



More references available in the CP Socket Catalog.

Scan this QR code to directly display all our socket references, for 1/4", 3/8", 1/2", 3/4" and 1" square drive.

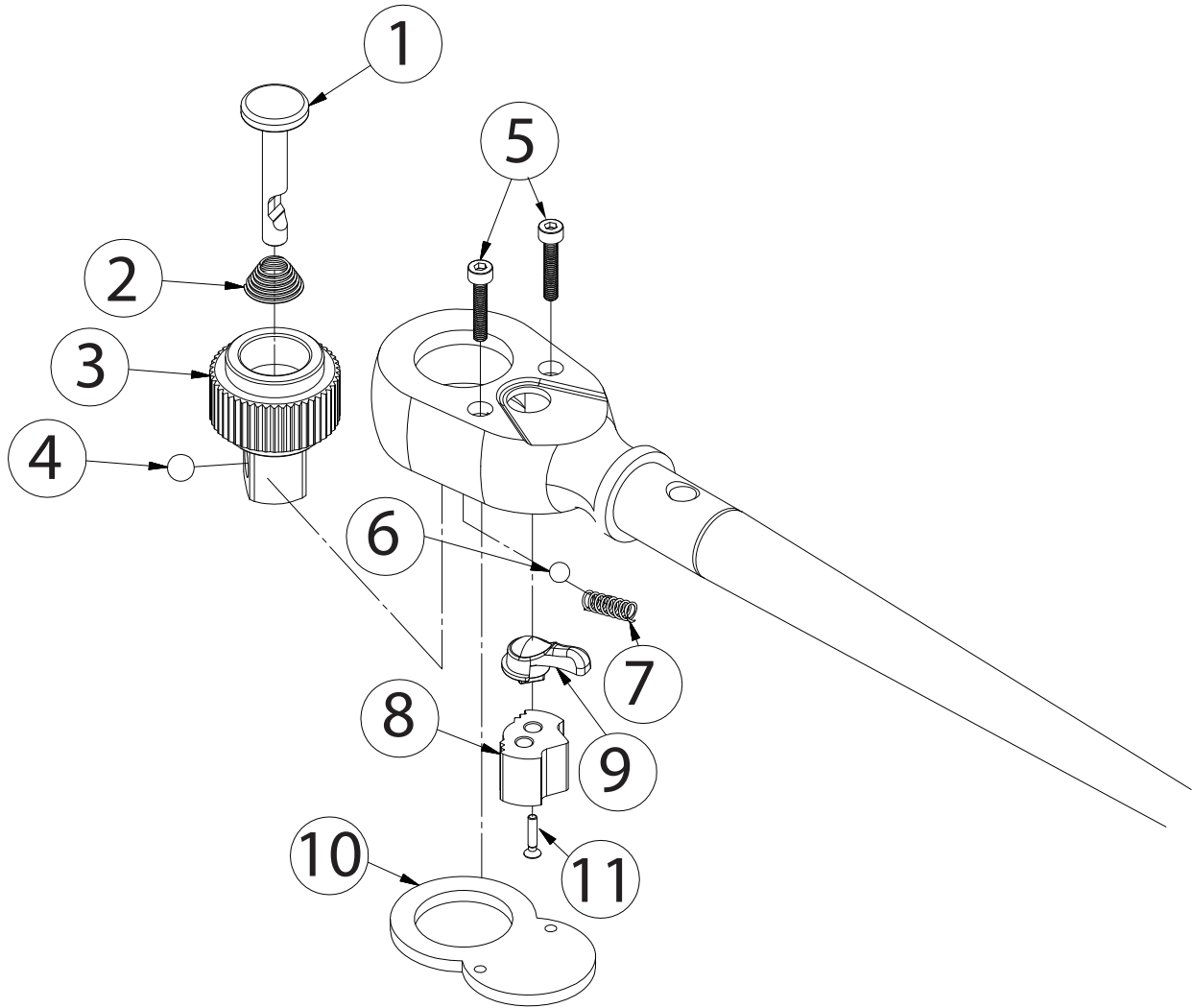

Part No.	Ref.	Description	Qty
HRK	8940171924	HEAD REPAIR KIT 3/4"	1
1		Pin	1
2		Spring	1
3		Anvil	1
4		Metal Ball	1
5		Screws	2
6		Metal Ball	1
7		Spring	1
8		Jaws	1
9		Lever	1
10		Plate	1
11		ScREW	1

Look through our comprehensive collection of wrenches and sets right away.