



Operator's Manual

**CP86150 / CP86200 / CP86300 / CP86500
HYDRAULIC PRESS**



WARNING

To reduce risk of injury, everyone using, installing, repairing, maintaining, changing accessories on, or working near this tool must read and understand these instructions, as well as separately provided safety instructions part number 8940170883, before performing any such task.

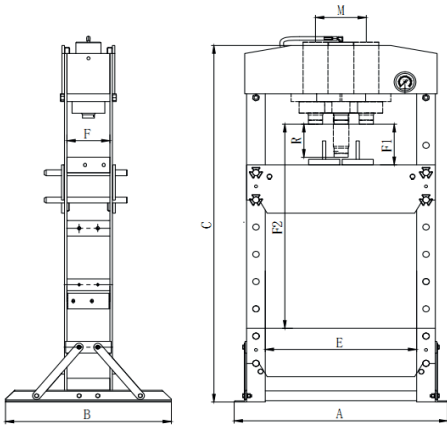

Fig. 01

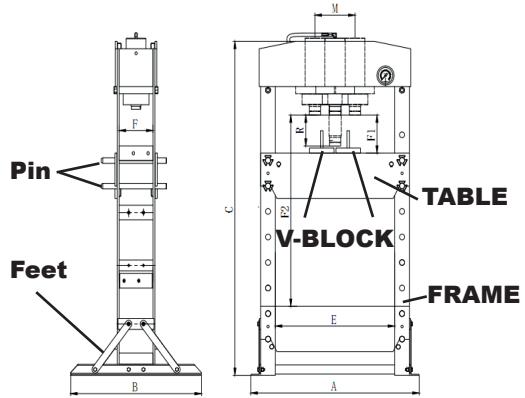

Fig. 02

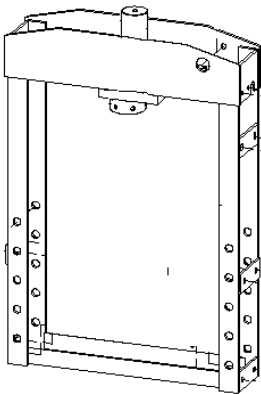

Fig. 03

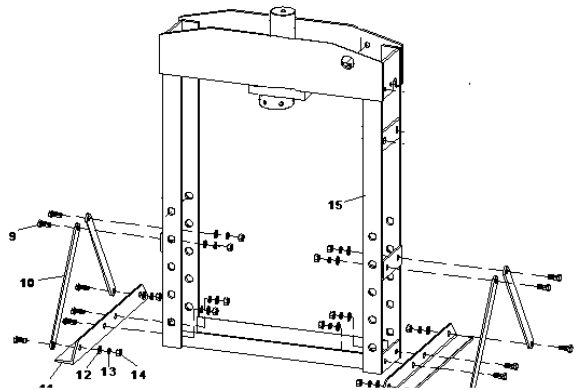

Fig. 04

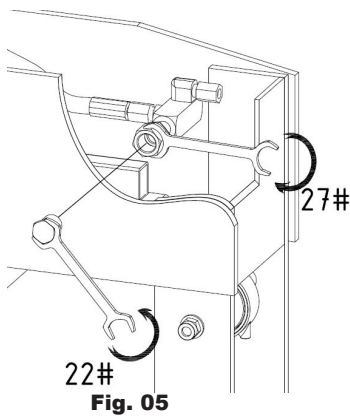

Fig. 05

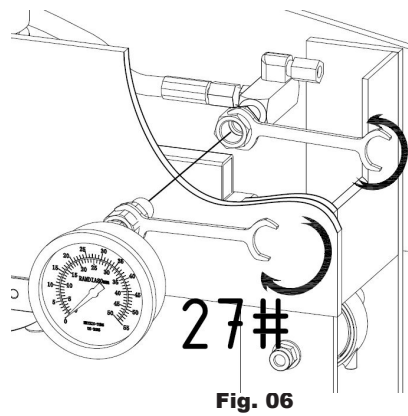

Fig. 06

CP86150

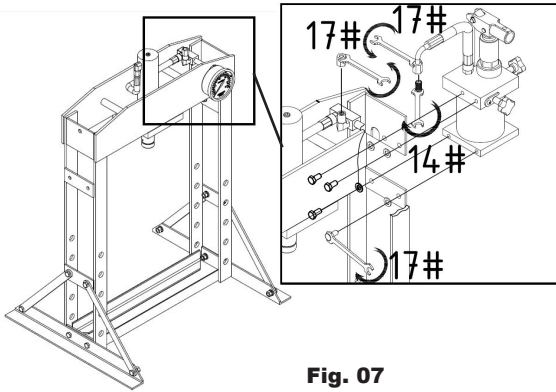

Fig. 07



Fig. 08

CP86200

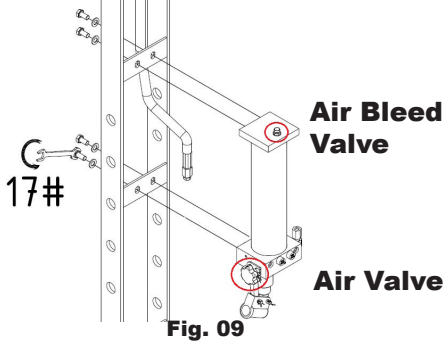

Fig. 09



Fig. 10

CP86300 & CP86500

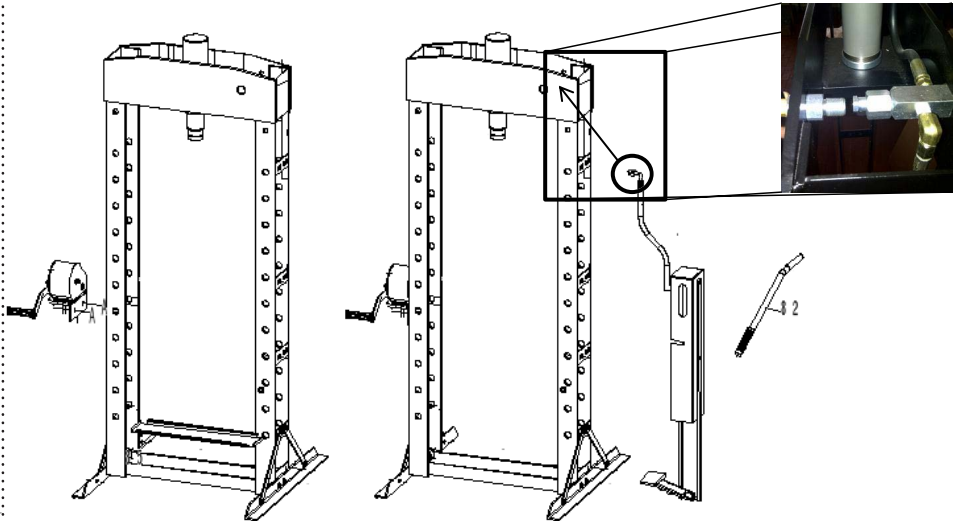

Fig. 10

Fig. 11

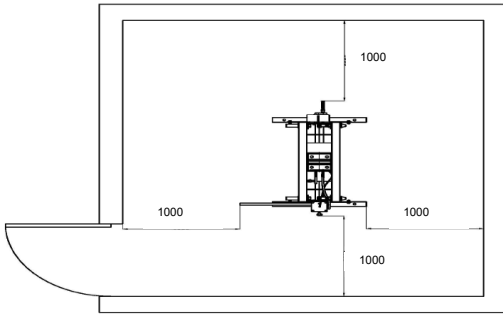

Fig. 12

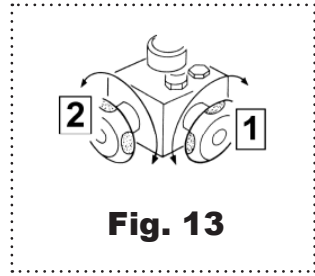

Fig. 13

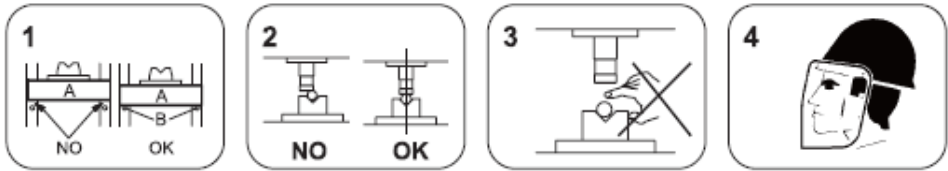

Fig. 14

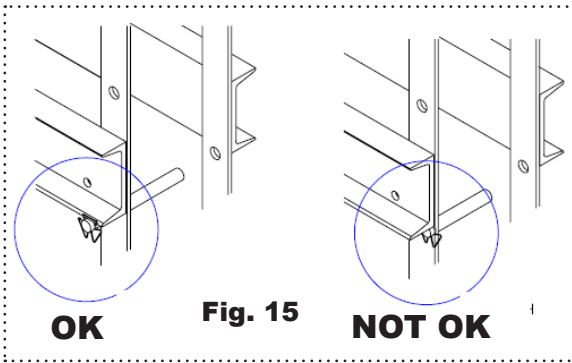

Fig. 15

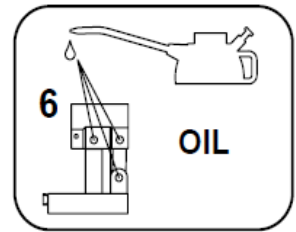

Fig. 16

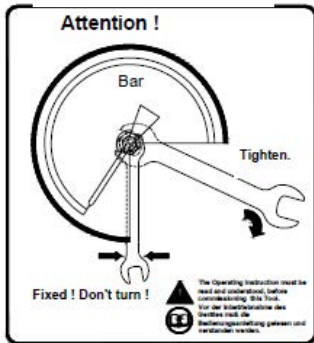

Fig. 17

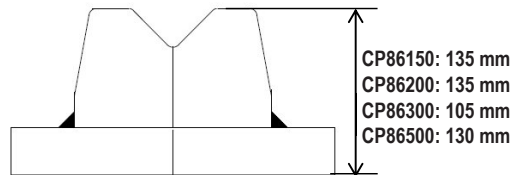
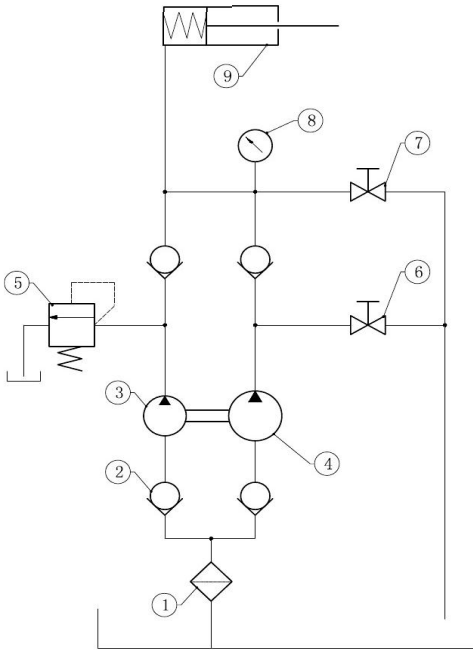

Fig.18

CP86150: 135 mm
 CP86200: 135 mm
 CP86300: 105 mm
 CP86500: 130 mm

CP86150



CP86200

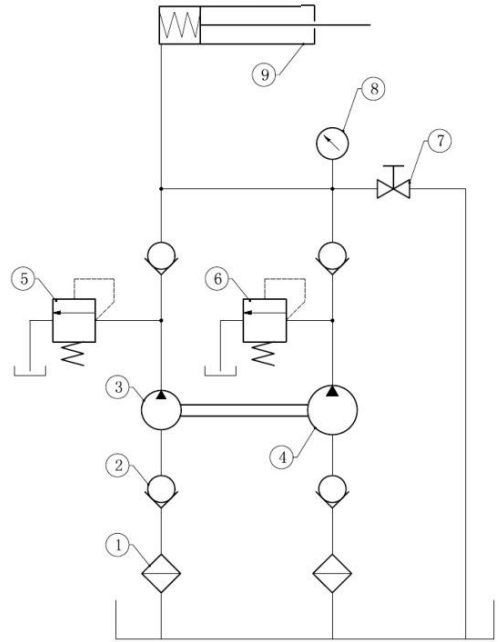

CP86500

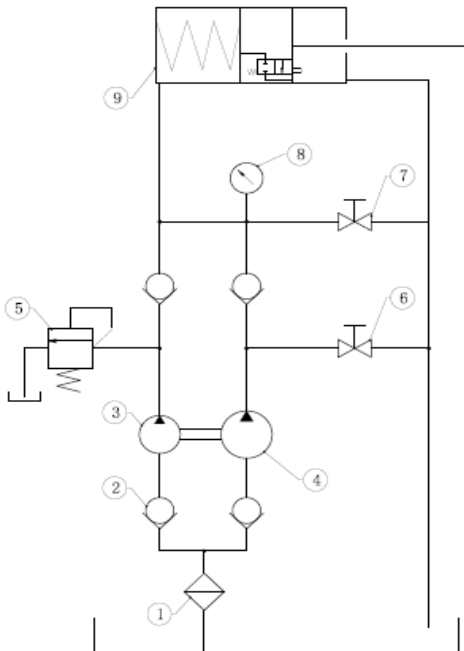

	Designation	WP15 WP30P	WP20S	WP50P
1	Oil-filter screen	1	2	1
2	Non-return valve	4	4	4
3	High pressure pump1	1	1	1
4	Low pressure pump1	1	1	1
5	High pressure overflow valve	1	1	1
6	Low pressure overflow valve	/	1	/
7	Unloading valve	1	1	1
8	Manometer	1	1	1
9	Oil cylinder	1	1	1

Technical Data (See figure 1.)

Dimension		CP86150	CP86200	CP86300	CP86500
capacity	[kg]	15 000	20 000	30 000	50 000
A	[mm]	700	740	795	1030
B	[mm]	540	700	700	800
C	[mm]	882	1772	1772	1830
F	[mm]	120	132	140	207
E	[mm]	500	510	535	730
F1	[mm]	157	185	151	68
F2	[mm]	457	1175	1031	1048
R	[mm]	160	186	160	200
M	[mm]	/	/	200	245
oil	[l]	0,6	0,95	1,1	2,5
Weight	[kg]	75,5	105	166,7	298
max. pressure	[MPa]	61	69	58	62

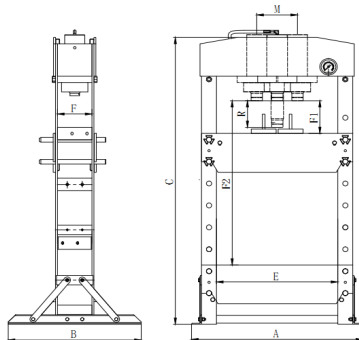

All values are current as of the date of this publication. For the latest information please visit www.cp.com.

Machine type(s)

- The machinery described is intended for machinery production and assembling spare parts. It is used to press, size, assemble, rivet small parts in process. No other use permitted. For professional use only.
- Please read the instructions carefully before starting the machine.

Mounting instruction

Make sure every parts are fixed and tightened.

- Attach the base section and support to left and right connecting plate. (Fig. 04)
- Assemble the nylon ring to gauge fitting, then put the pressure gauge and twist tight. (Fig. 06)
- Remark: twist as tight as possible, otherwise it will be leak. Attach the gauge fitting to the suitable upper cross beam and twist bolt.
- Assemble pump to the frame. Fig. 07 (CP86150), Fig. 09 (CP86200), Fig. 11 (CP86300 & CP86500).
- Insert the complete handle into the opening of the lever support.
- During moving the machine, make sure to use the proper lifting equipment and follow the instructions as shows (Fig. 02).

⚠ Caution Working area of 1 m must be kept free both in front of and behind the machine while it is in operation so that it is always easily accessible.

Purge air from the hydraulic system:

- Open the release valve by turning it counterclockwise and purge the air bleed valve (Fig. 09)
- Pump several full strokes to eliminate any air in the system.

Operation

⚠ Caution Ensure table at proper position and lock the table by 4 pins firmly. (Fig.15)

- For CP86150, CP86300 and CP86500, Close the release valve and the control valve, by turning it clockwise.

Note : The 2-speed pump is switched for a fast approach.

For CP86200, Close the release valve, by turning it clockwise.

Note : CP86200 has an Automatic 2-speed hydraulic pump, equipped with an automatic valve instead of a control valve.

- Pump the handle/foot pedal until serrated saddle nears workpiece.
- Align workpiece and ram to ensure center loading.
- For CP86150, CP86300 and CP86500, Close the control valve, by turning it Anticlockwise (slow position).

Note : The 2-speed pump is switched for a powerful pressing.

⚠ Caution Caution : When applying the load (15 t, 30t or 50t), the control valve must be closed (slow position) to avoid damage on system parts.

- Pump the handle/foot pedal to apply load onto workpiece (see numeration in pressure gauge).
- When work is done, stop pumping, slowly and carefully remove load from workpiece by turning the release valve counterclockwise in small increments. (must turn with the small angle)
- Once ram has fully retracted, remove workpiece from table.

⚠ WARNING The V-block must be used by pair, not by piece!

⚠ WARNING Only one person is allowed to operate the press.

⚠ WARNING Make sure that the operator must wear protective cloth, gloves, safety helmet, shoes and ear protector during operating.

⚠ WARNING To avoid accidents, always be aware of any on-going work on the machine. Also, always stay focused on the job to be done.

Maintenance instruction

⚠ Caution Do not use damaged/deformed product. If abnormal noise or vibration occurs, stop use immediately, then inspect and ask manufacturer for help. It is recommended that this inspection be made by a manufacturer's or supplier's authorized repair facility.

The greatest single cause of failure in hydraulic units is dirt.

- Keep the service jack clean and well lubricated to prevent foreign matter from entering the system. If the jack has been exposed to rain, snow, sand, or grit, it must be cleaned before it is used.
- Store the jack, with pistons completely retracted, in a well-protected area where it will not be exposed to corrosive vapors, abrasive dust, or any other harmful elements.
- Periodically check the condition of the product.
- Store the product in dry and non-corrosion environment.
- Owners and/or operators should be aware that repair of this equipment may require specialized knowledge and facilities. It is recommended that an annual inspection of the product be made by a manufacturer's or supplier's authorized repair facility and that any defective parts, decals, or safety labels or signs be replaced with manufacturer's or supplier's specified parts. A list of authorized repair facilities is available from the manufacturer or supplier, please call them for help.
- Any product that appears to be damaged in any way, is found to be worn, or operates abnormally SHALL BE REMOVED FROM SERVICE UNTIL REPAIRED. It is recommended that necessary repairs be made by a manufacturer's or supplier's authorized repair facility if repairs are permitted by the manufacturer or supplier.
- Only attachments and/or adapters supplied by the manufacturer shall be used.

Trouble Shooting

Fault	Cause	Remedy
The pump is working, while the ram can't work	1.The oil pipe loosed the ram is leaking	1.Checking the connecting situation of oil pipes, replace the oil seals
When open release vavle, the ram can't reset	1.The oil pipe loosed 2.No enough space un pump 3.The ram become invalid	1.Checking the connecting situation of oil pipes 2.Open exhaust valve 3.Replace the ram
Manual normal, while ram can't work	1.Release valve not complete closed 2.air in system	1.check the release valve 2.Purge away the air according manual
The ram can't fully work	1.The oil is not enough	1.Add oil
Oil leaking	1.Seal kits broken 2.Screw parts loosed	1.Replace the seal kits 2.Tighten the screw parts