



Chicago Pneumatic

Safety Information

Printed Matter No. 8940175594

Date: 2018-06 Issue No. 03

Impact Wrench

Valid from Serial No. 00001X to 99999X

Model:

CP7782

CP7782-6

CP7782-SP6

CP7782TL-6



WARNING

To reduce risk of injury, everyone using, installing, repairing, maintaining, changing accessories on, or working near this tool **MUST** read and understand these instructions before performing any such task.

DO NOT DISCARD - GIVE TO USER

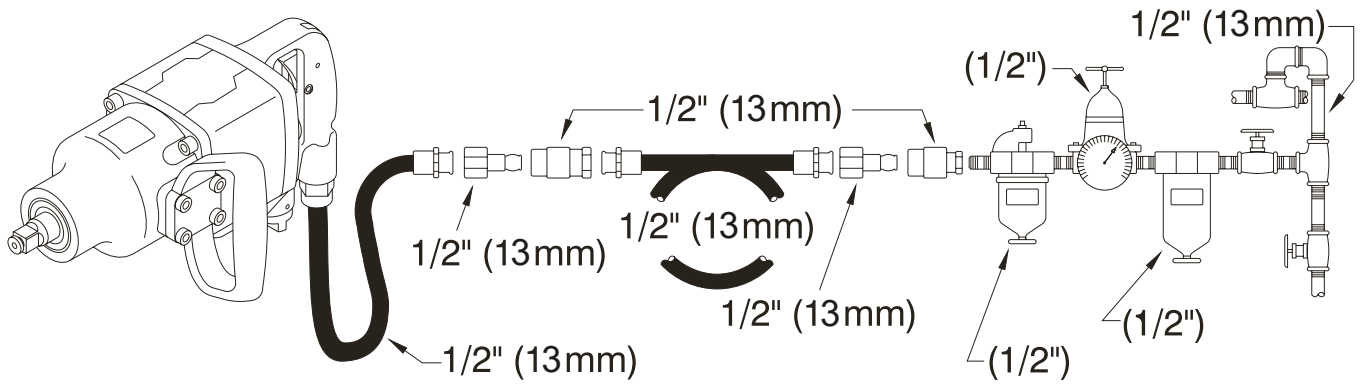

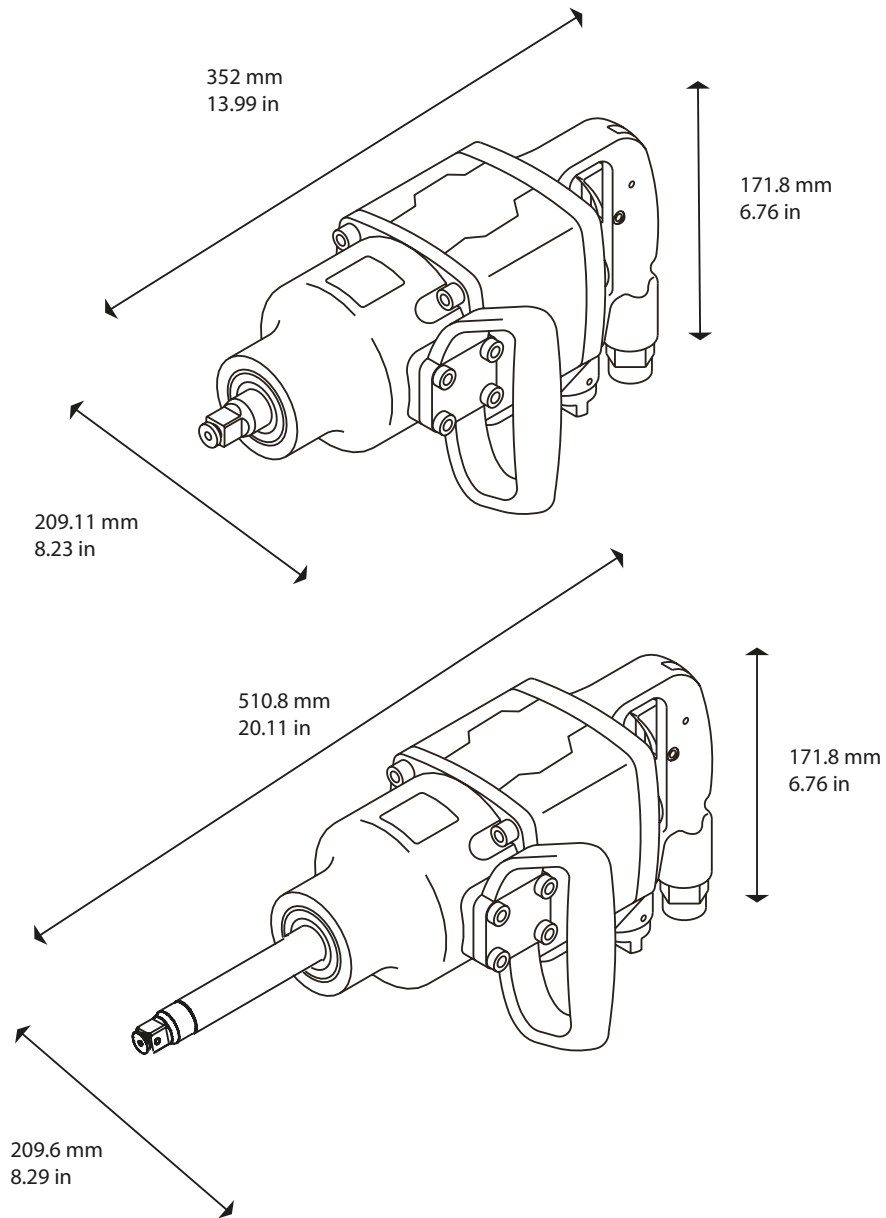

Technical data

Tool data

	CP77 82- SP6	CP77 82TL- 6	CP77 82-6	CP77 82
Blows per minute	500	500	500	500
Free speed (rpm)	5200	5200	5200	5200
Max. torque (re- verse) (ft.lb)	1920	1920	1920	1920
Max. torque (re- verse) (Nm)	2600	2600	2600	2600
Max. working torque (Nm)	2000	440	2000	2000
Max. working torque forward (ft.lb)	1475	325	1475	1475
Min. working torque forward (ft.lb)	370	295	370	370
Min. working torque (Nm)	500	400	500	500
Square drive (")	#5 spline	1	1	1
Actual air con- sumption (l/s)	19.2	19.2	19.2	19.2
Actual air con- sumption (cfm)	40.7	40.7	40.7	40.7
Min. hose size (")	0.5	0.5	0.5	0.5
Min. hose size (mm)	13	13	13	13
Air inlet thread size (")	1/2	0.5	0.5	1/2
Weight (kg)	11.6	11.6	11.6	10.1
Weight (lb)	25.55	25.55	25.55	22.2

Declarations

EU DECLARATION OF CONFORMITY

We, **CHICAGO PNEUMATIC Tool Co. LLC**, 1815 Clubhouse Road, Rock Hill, SC 29730, declare under our sole responsibility that the product (with name, type and serial number, see front page) is in conformity with the following Direc-
tive(s):

2006/42/EC (17/05/2006)

Harmonized standards applied:

EN ISO 11148-6:2012

Pascal ROUSSY

Signature of issuer

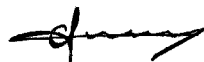

Noise and vibration

	CP7782	CP7782- 6	CP7782- SP6	CP7782 TL-6
Sound pressure level (dB(A))	100	100	100	100
Sound power level (dB (A))	111	111	111	111
	ISO 15744	ISO 15744	ISO 15744	ISO 15744
Vibra- tion (m/ s ²)	7.8	7.8	7.8	7.8
Vibration uncer- tainty	1.8	1.8	1.8	1.8
Vibration standard	ISO-289 27-2	ISO-289 27-2	ISO-289 27-2	ISO-289 27-2

These declared values were obtained by laboratory type testing in accordance with the stated standards and are suitable for comparison with the declared values of other tools tested in accordance with the same standards. These declared values are not adequate for use in risk assessments and values measured in individual work places may be higher. The actual exposure values and risk of harm experienced by an individual user are unique and depend upon the way the user works, the workpiece and the workstation design, as well upon the exposure time and the physical condition of the user.

We, **CHICAGO PNEUMATIC Tool Co. LLC**, cannot be held liable for the consequences of using the declared values, instead of values reflecting the actual exposure, in an individual risk assessment in a work place situation over which we have no control.

This tool may cause hand-arm vibration syndrome if its use is not adequately managed.

We recommend a programme of health surveillance to detect early symptoms which may relate to noise or vibration exposure, so that management procedures can be modified to help prevent future impairment.

- i** If this equipment is intended for fixtured applications:
The noise emission is given as a guide to the machine-builder. Noise and vibration emission data for the complete machine should be given in the instruction manual for the machine.

Safety

⚠ WARNING Risk of Property Damage or Severe Injury

Ensure that you read, understand and follow all instructions before operating the tool. Failure to follow all the instructions may result in electric shock, fire, property damage and/or severe bodily injury.

- ▶ Read all Safety Information delivered together with the different parts of the system.
- ▶ Read all Product Instructions for installation, operation and maintenance of the different parts of the system.
- ▶ Read all locally legislated safety regulations regarding the system and parts thereof.
- ▶ Save all Safety Information and instructions for future reference.

Statement of use

This product is designed for installing and removing threaded fasteners in wood, metal or plastic.

No other use permitted. For professional use only.

⚠ WARNING Risk of injury

- ▶ If the torque is higher than 50 Nm, a reaction bar must be used.

The reaction bar is designed for absorbing the reaction torque of assembly power tools.

Product specific instructions

Operation

See figures on page 2.

- Fix the accessories properly to the tool.
- Connect device to a clean and dry air supply.
- To start the machine, pull the trigger (A). Machine speed is increase by increasing pressure on the trigger. Release the trigger to stop.
- To switch rotation, push the switch (B). Use the reverse switch (B) only when the drive spindle comes to a complete stop. Changing the speed before the drive spindle stops may damage the machine.
- To adjust output power, turn the regulator (B).

The Torque Limited Impact Wrench is intended for initial tightening of wheel lug nuts and bolts. Final torque should be applied manually using a calibrated torque wrench, and following the vehicle manufacturer's instructions.

Lubrication

Use an air line lubricator with SAE #10 oil, adjusted to two (2) drops per minute. If an air line lubricator cannot be used, add air motor oil to the inlet once a day.

Clutch lubrication

Use 0.5 oz. (14 g) of CP Pneu-Lube Synthetic Clutch grease.

Maintenance instructions

- **Follow local country environmental regulations for safe handling and disposal of all components.**
- Maintenance and repair work must be carried out by qualified personnel using only original spare parts. Contact the manufacturer or your nearest authorised dealer for advice on technical service or if you require spare parts.

- Always ensure that the machine is disconnected from energy source to avoid accidental operation.
- Disassemble and inspect the tool every three 3 months if the tool is used every day. Replace damaged or worn parts.
- To keep downtime to a minimum, the following service kit is recommended : **Tune-up kit**

Disposal

- The disposal of this equipment must follow the legislation of the respective country.
- All damaged, badly worn or improperly functioning devices **MUST BE TAKEN OUT OF OPERATION.**
- The disposal of this equipment must follow the legislation of the respective country.
- Repair only by technical maintenance staff.

General safety instructions

To reduce risk of injury, everyone using, installing, repairing, maintaining, changing accessories on, or working near this tool must read and understand these instructions before performing any such task.

Our goal is to produce tools that help you work safely and efficiently. The most important safety device for this or any tool is YOU. Your care and good judgment are the best protection against injury. All possible hazards cannot be covered here, but we have tried to highlight some of the important ones.

- Only qualified and trained operators should install, adjust or use this power tool.
- This tool and its accessories must not be modified in any way.
- Do not use this tool if it has been damaged.
- If the rated speed, operating pressure or hazard warning signs on the tool cease to be legible or become detached, replace without delay.

For additional safety information consult:

- Other documents and information packed with this tool.
- Your employer, union and / or trade association.
- “Safety Code for Portable Air Tools” (ANSI B186.1), available at the time of printing from Global Engineering Document.
- Further occupational health and safety information can be obtained from the following web sites.

Air supply and connection hazards

- Air under pressure can cause severe injury.
- Always shut off air supply, drain hose of air pressure and disconnect tool from air supply when not in use, before changing accessories or when making repairs.
- Never direct air at yourself or anyone else.
- Whipping hoses can cause severe injury. Always check for damaged or loose hoses and fittings.
- Do not use quick disconnect couplings at tool. See instructions for correct set up.
- Whenever universal twist couplings are used, lock pins must be installed.
- Do not exceed maximum air pressure of 6.3 bar / 90 psig, or as stated on tool nameplate.

Entanglement hazards

- Keep away from rotating drive. Choking, scalping and / or lacerations can occur if loose clothing, gloves, jewellery, neck ware and hair are not kept away from tool and accessories.
- Gloves can become entangled with the rotating drive, causing severed or broken fingers.
- Rotating drive sockets and drive extensions can easily entangle rubber-coated or metal-reinforced gloves.
- Do not wear loose-fitting gloves or gloves with cut or frayed fingers.
- Never hold the drive, socket or drive extension.

Projectile hazards

- Always wear impact-resistant eye and face protection when involved with or near the operation, repair or maintenance of the tool or changing accessories on the tool.
- Be sure all others in the area are wearing impact-resistant eye and face protection. Even small projectiles can injure eyes and cause blindness.
- Serious injury can result from over-torqued or under-torqued fasteners, which can break, or loosen and separate. Released assemblies can become projectiles. Assemblies requiring a specific torque must be checked using a torque meter.

NOTE So-called “click” torque wrenches do not check for potentially dangerous over-torqued conditions.

- Use only impact wrench rated sockets and accessories in good condition. Sockets in poor condition or hand sockets and accessories used with impact wrenches can shatter.
- Never operate the tool off the work. It may run too fast and cause the accessory to be thrown off the tool.
- Ensure that the workpiece is securely fixed.

Accessory hazards

- Use only proper accessory retainers (see parts list). Use deep sockets wherever possible.
- For tools using the pin and O-ring socket retention system, use the O-ring to retain the socket pin securely.
- Always use the simplest hook-up possible. Long, springy extension bars and adapters absorb impact power and could break. Use deep sockets wherever possible.

Operating hazards

- Operators and maintenance personnel must be physically able to handle the bulk, weight and power of the tool.
- Hold the tool correctly: be ready to counteract normal or sudden movements – have both hands available.
- Do not use with reduced air pressure or in a worn condition: the clutch may not operate, resulting in sudden rotation of the tool handle.
- Be in control of the throttle at all times. Do not get caught between the tool and the work.

Repetitive motion hazards

- When using a power tool to perform work-related activities, the operator might experience discomfort in the hands, arms, shoulders, neck, or other parts of the body.
- Adopt a comfortable posture whilst maintaining secure footing and avoiding awkward or off-balance postures. Changing posture during extended tasks can help avoid discomfort and fatigue.
- Do not ignore symptoms such as persistent or recurring discomfort, pain, throbbing, aching, tingling, numbness, burning sensation, or stiffness. Stop using the tool, tell your employer and consult a physician.

Noise and Vibration hazards

- High sound levels can cause permanent hearing loss and other problems such as tinnitus. Use hearing protection as recommended by your employer or occupational health and safety regulations.
- Exposure to vibration can cause disabling damage to the nerves and blood supply of the hands and arms. Wear warm clothing and keep your hands warm and dry. If numbness, tingling, pain or whitening of the skin occurs, stop using tool, tell your employer and consult a physician.
- Hold the tool in a light but safe grip because the risk from vibration is generally greater when the grip force is higher. Where possible use a suspension arm or fit a side handle.
- To prevent unnecessary increases in noise and vibration levels:
- Operate and maintain the tool, and select, maintain and replace the accessories and consumables, in accordance with this instruction manual;
- Do not use worn or ill-fitting screwdriver bits, sockets or extensions.
- Do not touch sockets or accessories during impacting.

Workplace hazards

- Slip/Trip/Fall is a major cause of serious injury or death. Be aware of excess hose left on the walking or work surface.
- Avoid inhaling dust or fumes or handling debris from the work process which can cause ill health (for example, cancer, birth defects,

asthma and/or dermatitis). Use dust extraction and wear respiratory protective equipment when working with materials which produce airborne particles.

- Some dust created by power sanding, sawing, grinding, drilling and other construction activities contains chemicals known to the State of California to cause cancer and birth defects or other reproductive harm. Some examples of these chemicals are:
 - Lead from lead based paints
 - Crystalline silica bricks and cement and other masonry products
 - Arsenic and chromium from chemically-treated rubber

Your risk from these exposures varies, depending on how often you do this type of work. To reduce your exposure to these chemicals: work in a well ventilated area, and work with approved safety equipment, such as dust masks that are specially designed to filter out microscopic particles.

- Proceed with care in unfamiliar surroundings. Be aware of potential hazards created by your work activity. This tool is not insulated from coming into contact with electric power sources.
- This tool is not recommended for use in potentially explosive atmospheres.

DO NOT DISCARD – GIVE TO USER
