



**Chicago
Pneumatic**

Manual

CP7711,CP7721 Series

1/4", 3/8" Butterfly Impact Wrench



WARNING

To reduce risk of injury, everyone using, installing, repairing, maintaining, changing accessories on, or working near this tool must read and understand these instructions, as well as separately provided safety instructions part number 6159948710, before performing any such task.

Air Diagram:

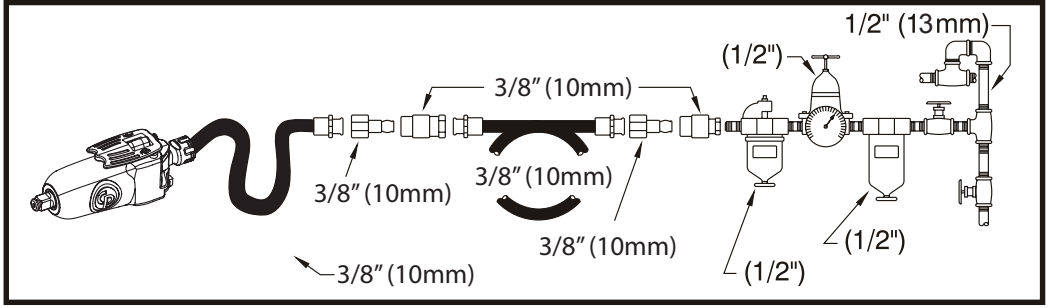

Fig. 1

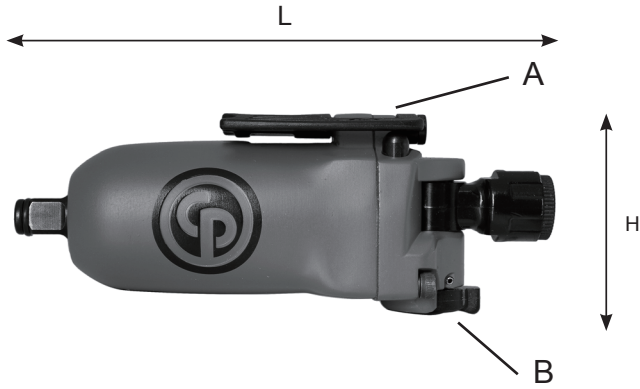

Fig. 2

Model	Drive	Torque		Speed	Weight	Inner Hose Dia.	Dimension L x W x H	Air Consumption		Air Inlet	Sound-Pressure L_{pA}	Sound-Power L_{WA}	Vibrations	
		Working	Max					Average	At load				ahd	k
	1	2	3	4	5	6	7	8	9	10	11			
	[inch]	[ft.lbs] [Nm]	[ft.lbs] [Nm]	[min ⁻¹]	[lb] [kg]	[inch.] [mm]	[inch.] [mm]	[SCFM] [NI/s]	[SCFM] [NI/s]	[inch]	[dB(A)]	[dB(A)]	[m/s ²]	[m/s ²]
CP7711	1/4"	6.6-59 9-80	81 110	15000	1.1 0.5	3/8" 10	5.5*1.6*2 140*40*50	1.5 0.7	6 2.9	1/4" NPT	92	103	4.0	1.0
CP7721	3/8"	6.6-59 9-80	81 110	15000	1.1 0.5	3/8" 10	5.5*1.6*2 140*40*50	1.5 0.7	6 2.9	1/4" NPT	92	103	4.0	1.0

Fig. 3

1. Technical Data (see Fig 2.)

Model	Drive	Torque		Speed	Weight	Inner Hose Dia.	Dimension L x W x H	Air Consumption		Air Inlet	Sound-Pressure L _{pA}	Sound-Power L _{wA}	Vibrations	
		Working	Max					Average	At load				ahd	k
	1	2	3	4	5	6	7	8	9	10	11			
	[inch]	[ft.lbs] [Nm]	[ft.lbs] [Nm]	[min-1]	[lb] [kg]	[inch.] [mm]	[inch.] [mm]	[SCFM] [NI/s]	[SCFM] [NI/s]	[inch]	[dB(A)]	[dB(A)]	[m/s ²]	[m/s ²]

max pressure 6.3 bar (90 psi)

ahd :Vibration level, k Uncertainty ; L_{pA} Sound pressure level dB(A), K_{pA} = KWA = 3 dB Uncertainty.

Declaration of noise (ISO 15744) and vibration emission (ISO 28927-2)

All values are current as of the date of this publication.

These declared values were obtained by laboratory type testing in accordance with the stated standards and are suitable for comparison with the declared values of other tools tested in accordance with the same standards. These declared values are not adequate for use in risk assessments and values measured in individual work places may be higher. The actual exposure values and risk of harm experienced by an individual user are unique and depend upon the way the user works, the workpiece and the workstation design, as well upon the exposure time and the physical condition of the user.

We, CHICAGO PNEUMATIC TOOLS, cannot be held liable for the consequences of using the declared values, instead of values reflecting the actual exposure-re, in an individual risk assessment in a work place situation over which we have no control.

This tool may cause hand-arm vibration syndrome if its use is not adequately managed.

We recommend a programme of health surveillance to detect early symptoms which may relate to noise or vibration exposure, so that management procedures can be modified to help prevent future impairment.

2. Machine Type

- This product is designed for installing and removing threaded fasteners in wood, metal and plastic. No other use permitted. For professional use only.
- Please read the product safety information carefully!

3. Implementation and Operation

- Connect device as shown in Fig.01.
- Fix the accessories properly to the tool.
- To operate in reverse rotation, turn the switch (A) to the left. To operate in forward rotation, turn the switch (A) to the right.
- To start the machine, simply turn the switch (A). Machine speed is increase by increasing pressure on the switch. Release the switch to stop.
- This impact wrench is equipped with a regulator (B) to enable adjustment of output power. Turn the regulator knob clockwise for maximum power, counter-clockwise to reduce power.
- Reverse the switch (A) only when the drive spindle comes to a complete stop. Changing the speed before the drive spindle stops may damage the machine.

4. Lubrication

• Motor Lubrication

Use an air line lubricator with SAE #10 oil, adjusted to two (2) drops per minute. If an air line lubricator cannot be used, add air motor oil to the inlet once a day. Recommended lubricant CP Oil PROTECTO-LUBE:

- 4 oz (0.12l) P/N: CA149661
- 20.8 oz (0.591l) P/N: CA000046
- 1gal (3.8l) P/N: P089507

• Clutch Lubrication

Use CP Pneu-Lube Synthetic Clutch Grease 8940158455.

5. Maintenance

- Follow local country environmental regulations for safe handling and disposal of all components
- Disassemble and inspect the tool every three 3 months if the tool is used every day. Replace damaged or worn parts.
- Always ensure that the machine is disconnected from energy source (compressed air) to avoid accidental operation.
- High wear parts are underlined in the parts list.
- To keep downtime to a minimum, the following service kits are recommended:
Tune-Up Kit: see part list

6. Disposal

- The disposal of this equipment must follow the legislation of the respective country.
- All damaged, badly worn or improperly functioning devices MUST BE TAKEN OUT OF OPERATION.
- Repair only by technical maintenance staff.**

7. Declaration of conformity

We : CHICAGO PNEUMATIC Tool Co.

Declare that the product(s): **Impact Wrench**

Machine type(s) : **CP7711,CP7721**

Serial Number: **From 00001 to 99999**

Origin of the product : **Taiwan**

is in conformity with the requirements of the council Directives on the approximation of the laws of the Member States relating to "Machinery" **2006/42/EC (17/05/2006)** applicable harmonised standard(s) : **EN ISO 11148-6:2012**

Name and position of issuer : **Pascal Roussy (R&D Manager)**

Place & Date : **Saint-Herblain, 15/03/2015**