



**Chicago  
Pneumatic**

# *Manual*

**CP7540, CP7545 & CP7550 Series  
4", 4 1/2" & 5" Angle Grinders**



## **WARNING**

*To reduce risk of injury, everyone using, installing, repairing, maintaining, changing accessories on, or working near this tool must read and understand these instructions, as well as separately provided safety instructions part number 6159948760, before performing any such task.*

# Air Diagram:

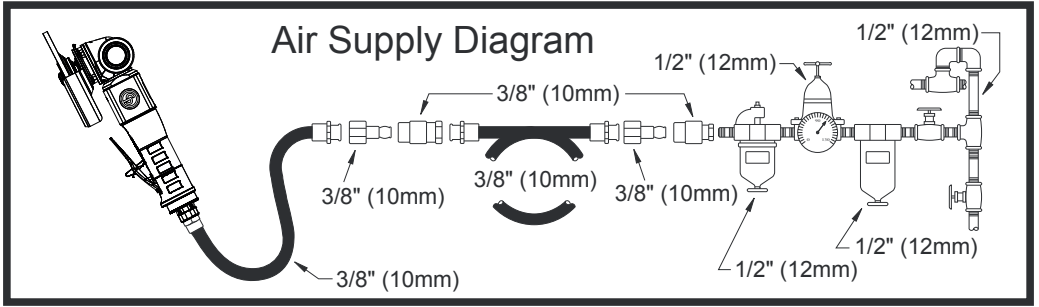

Fig. 1



Fig. 2

Model	Speed	Power	Wheel		Spindle thread	Air consumption at load	Weight	Dimension L×W×H	Air Inlet	Inner hose diameter	Sound Pressure	Sound Power	Vibrations	
	[RPM]	[HP] [W]	[in.] [mm]	[in.] [mm]		[SCFM] [NI/s]	[lb.] [kg]	[in.] [mm]	[in.]	[in.] [mm]	[dB(A)]	[dB(A)]	ahd	k
	1	2	3	4	5	6	7	8	9	10	11	12	13	14
CP7540-C	12,000	1.1 840	4	0.03 - 0.27 0.7 - 7	3/8"-24 UNF	40 18.9	3.5 1.6	10.6"9.1"3.6 270*230*93	1/4" NPT	3/8 10	85	96	6.5	3.0
CP7540-CN			100		3/8"-24 UNF			10.6"9.4"3.6 270*240*93						
CP7545-C			4.5		3/8"-24 UNF			10.6"9.4"3.6 270*240*93						
CP7545-B			115		5/8"-11 UNC			10.6"9.6"3.6 270*245*93						
CP7550-C			5		3/8"-24 UNF			10.6"9.6"3.6 270*245*93						
CP7550-B			125		5/8"-11 UNC									
CP7550-A					M14x2									

# CP7540, CP7545 & CP7550 Series

## 4", 4 1/2" & 5" Angle Grinder

### 1. Technical Data

Model	Speed	Power	Wheel		Spindle Thread	Air Consumption at load	Weight	Dimension LxWxH	Air Inlet	Inner Hose Dia.	Sound pressure $L_{pA}$	Soundpower $L_{wA}$	Vibrations	
													$a_{hd}$	K
	1	2	3	4	5	6	7	8	9	10	11	12	13	14
[RPM]	[Hp] [W]	[inch] [mm]	[inch] [mm]	/	[l/min] [SCFM]	[kg] [lb]	[inch] [mm]	[inch]	[inch]	[mm]	[dB(A)]	[dB(A)]	[m/s <sup>2</sup> ]	[m/s <sup>2</sup> ]

max. pressure 6.3bar(90psi)

$a_h$  : Vibration level, k Uncertainty ;  $L_{pA}$  Sound pressure dB(A),  $K_{pA} = K_{vib} = 3$  dB Uncertainty.

**Declaration of noise and vibration statement** (ISO 15744 and ISO 28927-10)

All values are current as of the date of this publication.

These declared values were obtained by laboratory type testing in accordance with the stated standards and are suitable for comparison with the declared values of other tools tested in accordance with the same standards. These declared values are not adequate for use in risk assessments and values measured in individual work places may be higher. The actual exposure values and risk of harm experienced by an individual user are unique and depend upon the way the user works, the workpiece and the workstation design, as well upon the exposure time and the physical condition of the user. We, CHICAGO PNEUMATIC TOOLS, cannot be held liable for the consequences of using the declared values, instead of values reflecting the actual exposure, in a individual risk assessment in a work place situation over which we have no control. This tool may cause hand-arm vibration syndrome if its use is not adequately managed. We recommend a programme of health surveillance to detect early symptoms which may relate to noise or vibration exposure, so that management procedures can be modified to help prevent future impairment.

### 2. Machine type(s)

- This product is designed for removing material using abrasives. No other use permitted. For professional use only.
- Please read the instructions carefully before starting the machine.

### 3. Operation

- Fix the accessories properly to the tool.
- Connect device as shown in Fig. 01.
- To start the machine, pull the trigger (A). Machine speed is increase by increasing pressure on the trigger. Release the trigger to stop.

### 4. Lubrification

#### Motor

- Use an air line lubricator with SAE #10 oil, adjusted to two drops per minute. If an air line lubricator cannot be used, add air motor oil to the inlet once a day.

#### Bevel gear

- Use Mobilux EP-2 or equivalent grease.

### 5. Maintenance instruction

#### Follow local country environmental regulations for safe handling and disposal of all components.

- Maintenance and repair work must be carried out by qualified personnel using only original spare parts. Contact the manufacturer or your nearest authorised dealer for advice on technical service or if you require spare parts.
- Always ensure that the machine is disconnected from energy source to avoid accidental operation.
- Disassemble and inspect the tool every three 3 months if the tool is used every day. Replace damaged or worn parts.
- High wear parts are underlined in the parts list.

### 6. Disposal

- The disposal of this equipment must follow the legislation of the respective country.
- All damaged, badly worn or improperly functioning devices MUST BE TAKEN OUT OF OPERATION.
- Repair only by technical maintenance staff.**

### 7. Declaration of conformity

We : **CHICAGO PNEUMATIC Tool Co.**

Machine type(s): **Angle Grinder**

Declare that the product(s): **CP7540-C, CP7540-CN, CP7545-C, CP7545-B, CP7550-C, CP7550-B & CP7550-A**

Serial Number: From **00001 to 99999**

Origin of the product : **Taiwan**

is in conformity with the requirements of the council Directives on the approximation of the laws of the Member States relating : to "Machinery" **2006/42/EC (17/05/2006)**

applicable harmonised standard(s) : **EN ISO 11148-7:2012**

Name and position of issuer : **Pascal Roussy(R&D Manager)**

Place & Date : Saint-Herblain, **04/06/2015**

Technical file available from EU headquarter. Pascal Roussy R&D manager CP Technocenter 38, rue Bobby Sands - BP10273 44800 Saint Herblain - France

### Copyright 2015, Chicago Pneumatic Tool Co. LLC

All rights reserved. Any unauthorized use or copying of the contents or part thereof is prohibited. This applies in particular to trademarks, model denominations, part numbers and drawings. Use only authorized parts. Any damage or malfunction caused by the use of unauthorized parts is not covered by Warranty or Product Liability.

Original Instructions

Learn more about pneumatic grinders we have.