



SAVE THESE INSTRUCTIONS. This manual contains important safety precautions which should be read and understood before operating the product. Failure to do so could result in serious injury. This manual should remain with the product.

Specifications, descriptions and illustrations in this manual are as accurate as known at the time of publication, but are subject to change without notice.

**TAKE IT
OUTSIDE™**



CARBON MONOXIDE KILLS

CARBON MONOXIDE SAFETY: THE BIG PICTURE

As the only safe way to use a portable generator, taking your generator outside is absolutely mandatory to keep your family safe from carbon monoxide. But there's even more you can do. By educating yourself about all carbon monoxide risks, you'll be better prepared to protect your family from this colorless, odorless threat.



**ALWAYS READ
THE OPERATOR'S
MANUAL FIRST**



KNOW THE SYMPTOMS

- Headache
- Nausea
- Shortness of breath
- Dizziness
- Fatigue

**STAY ALERT WITH CARBON
MONOXIDE DETECTORS**

**KEEP IT OUTSIDE AND AWAY FROM
DOORS, WINDOWS, AND GARAGES**

**IF YOU FEEL SYMPTOMS,
LEAVE RIGHT AWAY**

**POINT FUMES AWAY FROM
NEARBY PEOPLE**

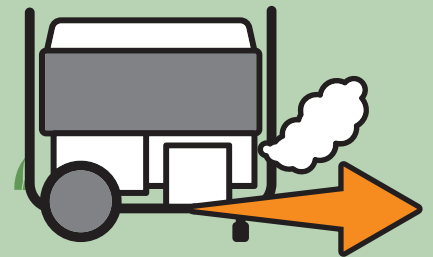

TABLE OF CONTENTS	
Introduction	4
Safety Definitions	4
Important Safety Instructions	5
Fuel Safety	7
Safety and Dataplate Labels	8
Safety Symbols	9
Operation Symbols	10
Quickstart Label Symbols	11
Controls and Features	12
Generator	12
Control Panel	13
Intelligauge	14
FCC Statement	15
Parts Included	15
Tools Needed	15
Assembly	16
Unpacking	16
Remove Shipping Support Spacers	16
Add Engine Oil	16
Add Fuel	17
Grounding	18
Operation	18
Generator Location	18
Surge Protection	19
Starting the Engine	19
Connecting Electrical Loads	20
Do Not Overload Generator	20
Eco (Economy) Mode	21
Parallel Operation	21
Stopping the Engine	21
Moving the Generator	22
Operation at High Altitude	22
Maintenance	22
Cleaning the Generator	22
Changing the Engine Oil	23
Cleaning and Adjusting the Spark Plug	23
Cleaning the Air Filter	23
Cleaning the Spark Arrestor	24
Adjusting the Governor	24
Maintenance Schedule	24
Storage	25
Short Term Storage (up to 30 days)	25
Mid Term Storage (30 days – 1 year)	25
Long Term Storage (over 1 year)	25
Removing from Storage	26
Specifications	27
Generator Specifications	27
Engine Specifications	27
Oil Specifications	27
Fuel Specifications	27
Temperature Specifications	27
Parts Diagram	28
Parts List	29
Engine Parts Diagram	31
Engine Parts List	32
Wiring Diagram	34
Troubleshooting	35

INTRODUCTION

Congratulations on your purchase of a Champion Power Equipment (CPE) product. CPE designs, builds, and supports all of our products to strict specifications and guidelines. With proper product knowledge, safe use, and regular maintenance, this product should bring years of satisfying service.

Every effort has been made to ensure the accuracy and completeness of the information in this manual at the time of publication, and we reserve the right to change, alter and/or improve the product and this document at any time without prior notice.

CPE highly values how our products are designed, manufactured, operated, and serviced as well as providing safety to the operator and those around the generator. Therefore, it is **IMPORTANT** to review this product manual and other product materials thoroughly and be fully aware and knowledgeable of the assembly, operation, dangers and maintenance of the product before use. Fully familiarize yourself, and make sure others who plan on operating the product fully familiarize themselves too, with the proper safety and operation procedures before each use. Please always exercise common sense and always err on the side of caution when operating the product to ensure no accident, property damage, or injury occurs. We want you to continue to use and be satisfied with your CPE product for years to come.

When contacting CPE about parts and/or service, you will need to supply the complete model and serial numbers of your product. Transcribe the information found on your product's nameplate label to the table below

CPE TECHNICAL SUPPORT TEAM
MODEL NUMBER
200955
SERIAL NUMBER
DATE OF PURCHASE
PURCHASE LOCATION

SAFETY DEFINITIONS

The purpose of safety symbols is to attract your attention to possible dangers. The safety symbols, and their explanations, deserve your careful attention and understanding. The safety warnings do not by themselves eliminate any danger. The instructions or warnings they give are not substitutes for proper accident prevention measures.

DANGER

DANGER indicates a hazardous situation which, if not avoided, will result in death or serious injury.

WARNING

WARNING indicates a hazardous situation which, if not avoided, could result in death or serious injury.

CAUTION

CAUTION indicates a hazardous situation which, if not avoided, could result in minor or moderate injury.

NOTICE

NOTICE indicates information considered important, but not hazard-related (e.g., messages relating to property damage).

IMPORTANT SAFETY INSTRUCTIONS

⚠ WARNING

Cancer and Reproductive Harm

⚠ DANGER

Generator exhaust contains carbon monoxide, a colorless, odorless, poisonous gas. Breathing carbon monoxide will cause nausea, dizziness, fainting or death. If you start to feel dizzy or weak, get to fresh air immediately.

OPERATE GENERATOR OUTDOORS ONLY IN A WELL VENTILATED AREA AND POINT EXHAUST AWAY.

DO NOT operate the generator inside any building, including garages, basements, crawlspaces and sheds, enclosure or compartment, including the generator compartment of a recreational vehicle.

DO NOT allow exhaust fumes to enter a confined area through windows, doors, vents or other openings.

⚠ DANGER

Using a generator indoors **CAN KILL YOU IN MINUTES.** Generator exhaust contains carbon monoxide. This is a poison you cannot see or smell.

NEVER use inside a home or garage, **EVEN IF** doors and windows are open.

ONLY use **OUTSIDE** and far away from windows, doors, and vents.

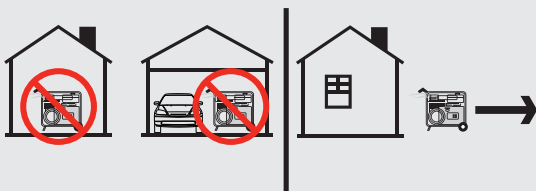

Install battery-operated carbon monoxide alarms or plug-in carbon monoxide alarms with battery back-up according to the manufacturer's instructions.

⚠ WARNING

Although the generator contains a spark arrester, maintain a minimum distance of 5 ft. (1.5 m) from dry vegetation to prevent fires.

⚠ DANGER

Operate equipment with guards in place.

Rotating parts can entangle hands, feet, hair, clothing and/or accessories. Traumatic amputation or severe laceration can result.

Keep hands and feet away from rotating parts.

Tie up long hair and remove jewelry.

DO NOT wear loose-fitting clothing, dangling drawstrings or items that could become caught.

⚠ DANGER

Generator produces powerful voltage.

DO NOT touch bare wires or receptacles.

DO NOT use electrical cords that are worn, damaged or frayed. Use only Champion electrical cords for proper application.

DO NOT operate generator in wet weather.

DO NOT allow children or unqualified persons to operate or service the generator.

Use a ground fault circuit interrupter (GFCI) in damp areas and areas containing conductive material such as metal decking.

Connection to your home's electrical system requires a listed 30A transfer switch installed by a licensed electrician and approved by the local authority having jurisdiction. The connection must isolate the generator from the utility power and must comply with all applicable laws and electrical codes.

⚠ WARNING

Do not use generator for medical and life support uses.

In case of emergency, call 911 immediately.

NEVER use this product to power life support devices or life support appliances.

NEVER use this product to power medical devices or medical appliances.

Inform your electricity provider immediately if you or anyone in your household depends on electrical equipment to live.

Inform your electrical provider immediately if a loss of power would cause you or anyone in your household to experience a medical emergency.

⚠ WARNING

Spark from removed spark plug wire can result in fire or electrical shock.

When servicing the generator:

Disconnect the spark plug wire and place it where it cannot contact the plug or any other metal object.

DO NOT check for spark with the plug removed.

Use only approved spark plug testers.

⚠ WARNING

Running engines produce heat. Severe burns can occur on contact. Combustible material can catch fire on contact.

DO NOT touch hot surfaces.

Avoid contact with hot exhaust gases.

Allow equipment to cool before touching.

Maintain at least 3 ft. (91.4 cm) of clearance on all sides to ensure adequate cooling.

Maintain at least 5 ft. (1.5 m) of clearance from combustible materials.

⚠ WARNING

Rapid retraction of the recoil cord will pull hand and arm towards the engine faster than you can let go. Broken bones, fractures, bruises or sprains could result. Unintentional startup can result in entanglement, traumatic amputation or laceration.

When starting engine, pull the recoil cord slowly until resistance is felt and then pull rapidly to avoid kickback.

DO NOT start or stop the engine with electrical devices plugged in and turned on.

⚠ CAUTION

Exceeding the generator's running capacity can damage the generator and/or electrical devices connected to it.

DO NOT overload the generator.

DO NOT tamper with the governed speed.

DO NOT modify the generator in any way.

⚠ CAUTION

Start the generator and allow the engine to stabilize before connecting electrical loads.

Connect electrical equipment in the off position, and then turn them on for operation.

Turn electrical equipment off and disconnect before stopping the generator.

⚠ CAUTION

Improper treatment or use of the generator can damage it, shorten its life or void the warranty.

Use the generator only for intended uses.

Operate only on level surfaces.

DO NOT expose generator to excessive moisture, dust, or dirt.

DO NOT allow any material to block the cooling slots.

If connected devices overheat, turn them off and disconnect them from the generator.

DO NOT use the generator if:

- Electrical output is lost
- Equipment sparks, smokes or emits flames
- Equipment vibrates excessively

Fuel Safety

⚠ DANGER

GASOLINE AND GASOLINE VAPORS ARE HIGHLY FLAMMABLE AND EXPLOSIVE.

Fire or explosion can cause severe burns or death.

Gasoline and gasoline vapors:

- Gasoline is highly flammable and explosive.
- Gasoline can cause a fire or explosion if ignited.
- Gasoline is a liquid fuel but it's vapors can ignite.
- Gasoline is a skin irritant and needs to be cleaned up immediately if spilled on skin or clothes.
- Gasoline has a distinctive odor, this will help detect potential leaks quickly.
- Gasoline expands or contracts with ambient temperatures. Never fill the gasoline tank to full capacity, as gasoline needs room to expand when temperatures rise.
- In the case of any petroleum gasoline fire, flames should never be extinguished unless the fuel supply valve can be turned OFF. By not doing so, if a fire is extinguished and the supply of fuel is not turned OFF, an explosion hazard could be created.

When adding or removing gasoline:

- DO NOT light or smoke cigarettes.
- Always turn the generator off and let cool for a minimum of two minutes before removing the gasoline cap. Afterwards, loosen gasoline cap to relieve pressure from the gasoline tank.
- Only fill or drain gasoline outdoors in a well-ventilated area.
- DO NOT pump gasoline directly into the generator at the gas station. Always use an approved fuel container to transfer the gasoline to the generator.
- DO NOT overfill the gasoline tank.
- Always keep gasoline away from sparks, open flames, pilot lights, heat and other sources of ignition.

When starting the generator:

- DO NOT attempt to start a damaged generator.
- Always make certain that the gasoline cap, air filter, spark plug, fuel lines and exhaust system are properly secured, connected and in place.
- Always allow spilled gasoline to evaporate fully before attempting to start the engine.
- Make certain that the generator is resting firmly on level ground.

When operating the generator:

- DO NOT move or tip the generator during operation.
- DO NOT tip the generator or allow fuel or oil to spill.

When transporting or servicing the generator:

- Make certain that the fuel valve is in the OFF position and the gasoline tank is empty.
- Disconnect the spark plug wire.

When storing the generator:

- Store away from sparks, open flames, pilot lights, heat and other sources of ignition.
- Do not store generator or gasoline near furnaces, water heaters, or any other appliances that produce heat or have automatic ignitions.

⚠ WARNING

Never use a gasoline container, gasoline tank, or any other fuel item that is broken, cut, torn or damaged.

Safety and Dataplate Labels

These labels warn you of potential hazards that can cause serious injury. Read them carefully.

If a label comes off or becomes hard to read, contact Technical Support Team for possible replacement.

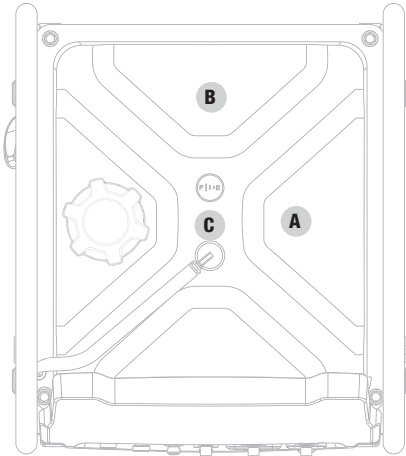

Top

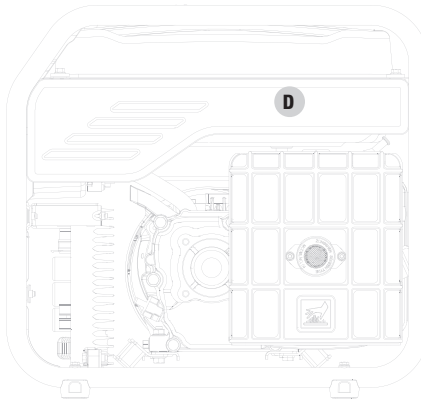

Side

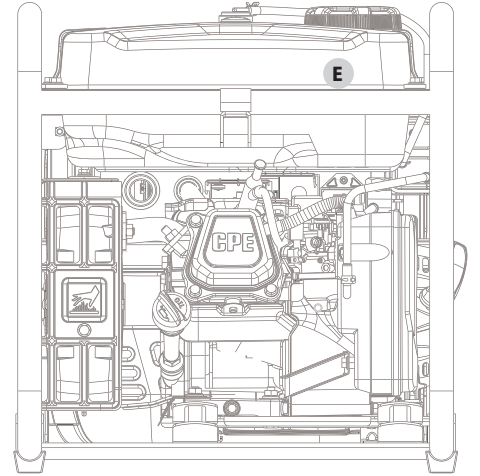





Back

	LABEL	DESCRIPTION																																				
A		CO Danger																																				
B		Safety Symbols																																				
C		Fuel																																				
D		Hot Surface																																				
E	<table border="1"> <tr> <td colspan="2">CHAMPION POWER EQUIPMENT, INC.</td> <td>FREQUENCY (Hz)</td> <td>60</td> <td>MAX AMBIENT TEMP.</td> <td>104°F</td> </tr> <tr> <td colspan="2"></td> <td>RPM</td> <td>3600</td> <td>INSULATION CLASS</td> <td>F</td> </tr> <tr> <td colspan="2"></td> <td>PHASE</td> <td>1</td> <td>GASOLINE WATTS</td> <td>3500</td> </tr> <tr> <td>MODEL</td> <td>200955</td> <td>POWER FACTOR</td> <td>1.0</td> <td colspan="2"></td> </tr> <tr> <td>SERIAL NO.</td> <td>XXXXXXXXXXXX</td> <td>AC VOLTS</td> <td>120</td> <td colspan="2"></td> </tr> <tr> <td>MANUFACTURE DATE</td> <td>XXXX</td> <td>AC AMPS</td> <td>29.2</td> <td colspan="2"></td> </tr> </table>	CHAMPION POWER EQUIPMENT, INC.		FREQUENCY (Hz)	60	MAX AMBIENT TEMP.	104°F			RPM	3600	INSULATION CLASS	F			PHASE	1	GASOLINE WATTS	3500	MODEL	200955	POWER FACTOR	1.0			SERIAL NO.	XXXXXXXXXXXX	AC VOLTS	120			MANUFACTURE DATE	XXXX	AC AMPS	29.2			Dataplate
CHAMPION POWER EQUIPMENT, INC.		FREQUENCY (Hz)	60	MAX AMBIENT TEMP.	104°F																																	
		RPM	3600	INSULATION CLASS	F																																	
		PHASE	1	GASOLINE WATTS	3500																																	
MODEL	200955	POWER FACTOR	1.0																																			
SERIAL NO.	XXXXXXXXXXXX	AC VOLTS	120																																			
MANUFACTURE DATE	XXXX	AC AMPS	29.2																																			









Safety Symbols









Some of the following symbols may be used on this product. Please study them and learn their meaning. Proper interpretation of these symbols will allow you to more safely operate the product.

SYMBOL	MEANING
	Read Operator's Manual. To reduce the risk of injury, user must read and understand operator's manual before using this product.
	Clearance. Keep all objects at least 5 feet (1.5m) from generator. Heat from the muffler and exhaust gas can ignite combustible objects.
	Ground. Consult with local electrician to determine grounding requirements before operation.
	Electric Shock. Failure to use in dry conditions and to observe safe practices can result in electric shock. Improper connections to a building can allow current to backfeed into utility lines, creating an electrocution hazard. A transfer switch must be used when connecting to a building.
	Fire/Explosion. Fuel and its vapors are extremely flammable and explosive. Fire or explosion can cause severe burns or death. Keep generator at least 5 feet (1.5m) from all objects to prevent combustion.
	Hot Surface. To reduce the risk of injury or damage, avoid contact with any hot surface.
	Open Flame Alert. Fuel and its vapors are extremely flammable and explosive. Keep fuel away from smoking, open flames, sparks, pilot lights, heat, and other ignition sources.
	Wet Conditions Alert. Do not expose to rain or use in damp locations.

Operation Symbols

Some of the following symbols may be used on this product. Please study them and learn their meaning. Proper interpretation of these symbols will allow you to more safely operate the product.

SYMBOL	MEANING
	On
	Stop or Off
	Economy Mode Button
	Low Oil
	Overload Reset Button
	Choke. Pull choke knob to “CHOKE” position.
	Run. Push choke knob to “RUN” position.
	USB Connection Port
	Parallel Connection(s)

SYMBOL	MEANING
	Hertz
	Volts
	Run time
	Circuit Breaker Reset: Push
	RV Ready Receptacle
	Neutral Floating. Neutral circuit IS NOT electrically connected to the frame/ground of the generator.
	Gasoline Tank: Full
	Gasoline Tank: Empty
	Fuel/Gasoline Valve On/Off

Quickstart Label Symbols

Some of the following symbols may be used on this product. Please study them and learn their meaning. Proper interpretation of these symbols will allow you to more safely operate the product.



Starting the Engine

⚠ DANGER

Move generator outside and far away from windows, doors and intake ventilation covers.

1. **Check oil level.**
Recommended oil is 10W-30.
2. **Check gasoline level.**
When adding gasoline, use a minimum octane rating of 87 and an ethanol content of 10% or less by volume.
3. Turn the fuel valve to **“ON”** position.
4. Press engine switch to the **“ON”** position.
5. Pull choke knob to **“CHOKE”** position.
6. Pull the recoil cord.
7. Push the choke knob to **“RUN”** position.
8. Plug in desired device.

Stopping the Engine

1. Turn off and unplug all connected electrical loads.
2. Press the engine switch to the **“OFF”** position.
3. Turn the fuel valve to the **“OFF”** position.

CONTROLS AND FEATURES

Read this operator's manual before operating your generator. Familiarize yourself with the location and function of the controls and features. Save this manual for future reference.

Generator

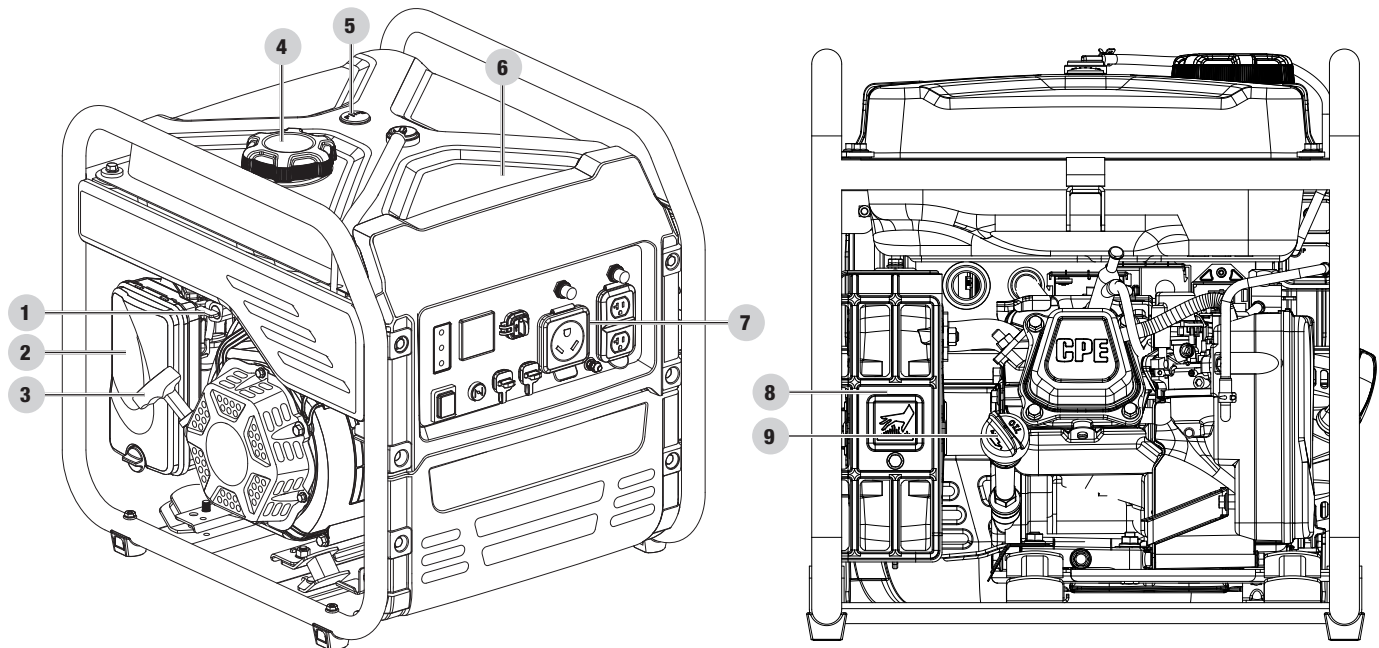

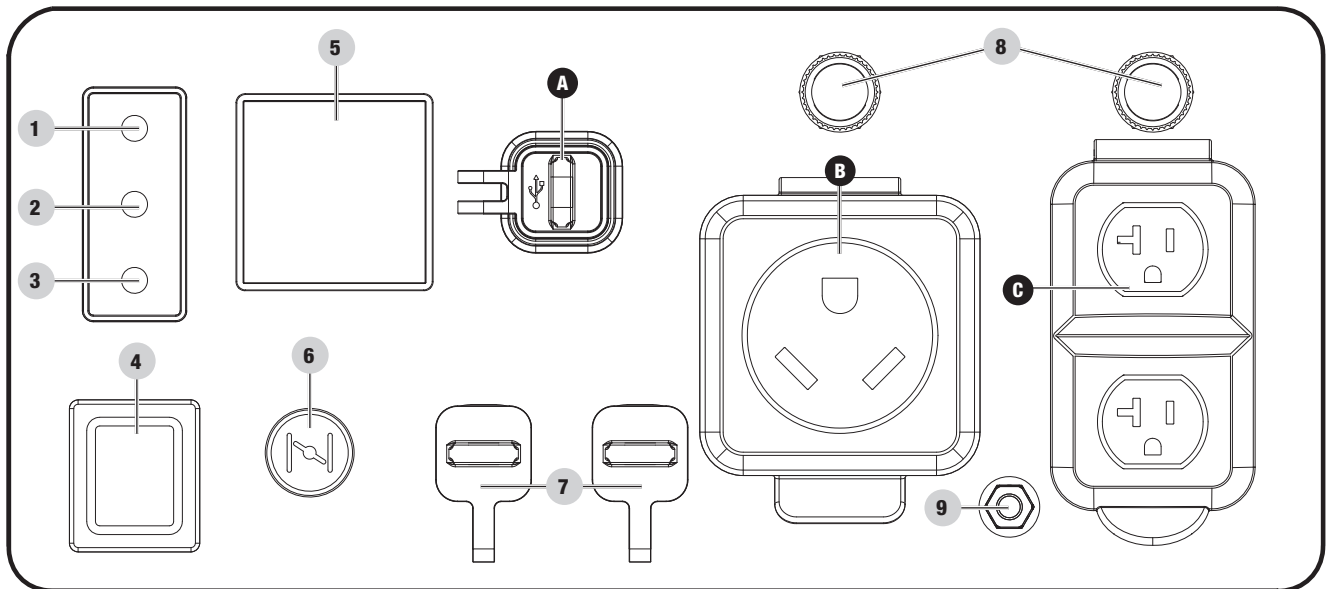

1. **Fuel Valve** – Used to turn fuel supply on and off to engine.
2. **Air Filter** – Protects the engine by filtering dust and debris from the intake air.
3. **Recoil Starter** – Used to manually start the engine.
4. **Fuel Cap** – Remove to add fuel.
5. **Gasoline Gauge**
6. **Gasoline Tank** – 4 gal. (15.2 L)
7. **Control Panel** – See *Control Panel* section.
8. **Muffler**
9. **Oil Fill Cap/Dipstick** – Used to check and fill oil level.

Control Panel



1. **Economy Mode Button** – Enables/disables automatic idle control.
2. **Low Oil Warning Indicator Light** – When ON, engine will shut down and not run. Check oil level.
3. **AC Overload Reset Button** – Used to re-energize receptacles after overload fault.
4. **Engine Switch** – Used to put in START mode or STOP the generator.
5. **Intelligauge** – Three mode digital meter for displaying total run time, voltage and hertz.
6. **Choke** – Used to start a cold engine.
7. **Parallel Outlets** – Used to parallel two inverters together for increased power output. (parallel kit sold separately).
8. **Circuit Breakers (Push Reset)** – Protects the generator against electrical overloads.
9. **Ground Terminal** – Consult an electrician for local grounding regulations.





RECEPTACLES	
A	 <p>(2×) 5V DC, 2.1A (USB Type-A) Each port may be used to supply a maximum of 5V, 2.1A to power cellphones, laptops, tablets, and similar devices.</p>
B	 <p>120V AC, 30A RV (NEMA TT-30R) May be used to supply electrical power for operation of 120 Volt AC, 30 Amp, single phase, 60 Hz electrical loads.</p>
C	 <p>(2×) 120V AC, 20A (NEMA 5-20R) May be used to supply electrical power for operation of 120 Volt AC, 20 Amp, single phase, 60 Hz electrical loads.</p>

Intelligauge

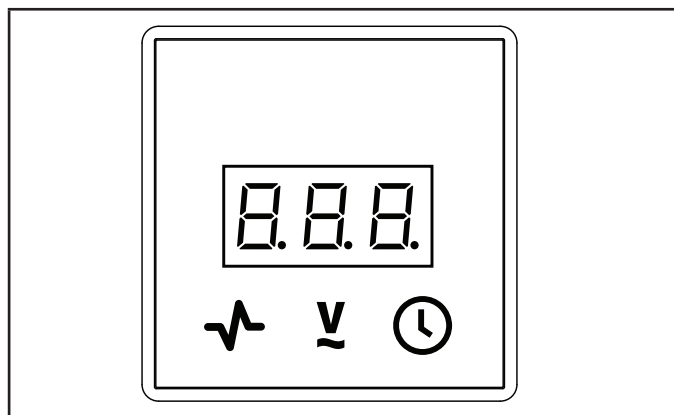
Three mode digital meter for displaying frequency (hertz), voltage, and total run time.

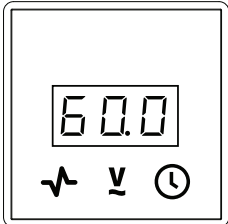
The LCD displays each mode for several seconds and then automatically cycles through.

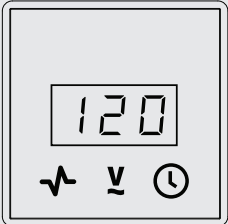

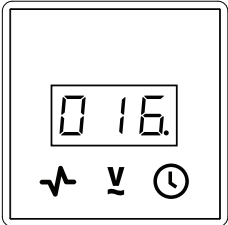
MODE	DESCRIPTION	
 Frequency (Hz)	Output frequency in hertz.	
	Example: 60.0 hertz	
 Voltage (V)	Output voltage of the generator.	
	Example: 120 volts	
 Total Run Time (Hrs.)	Total run time of the generator since first operation	
	Example: 16 hours	

FCC Statement

1. This device complies with Part 15 of the FCC Rules. Operation is subject to the following two conditions:
 - 1a. This device may not cause harmful interference.
 - 1b. This device must accept any interference received, including interference that may cause undesired operation.
2. Changes or modifications not expressly approved by the party responsible for compliance could void the user’s authority to operate the equipment.

▲ NOTICE

This equipment has been tested and found to comply with the limits for a Class B digital device, pursuant to Part 15 of the FCC Rules. These limits are designed to provide reasonable protection against harmful interference in a residential installation. This equipment generates, uses and can radiate radio frequency energy and if not installed and used in accordance with the instructions, may cause harmful interference to radio communications. However, there is no guarantee that interference will not occur in a particular installation. If this equipment does cause harmful interference to radio or television reception, which can be determined by turning the equipment off and on, the user is encouraged to try to correct the interference by one or more of the following measures:

- Reorient or relocate the receiving antenna.
- Increase the separation between the equipment and receiver.
- Connect the equipment into an outlet on a circuit different from that to which the receiver is connected.

Consult dealer or an experienced radio/TV technician for help.

Parts Included

Accessories

- Engine Oil 20.3 fl. oz. (600ml)
- Oil Funnel 1

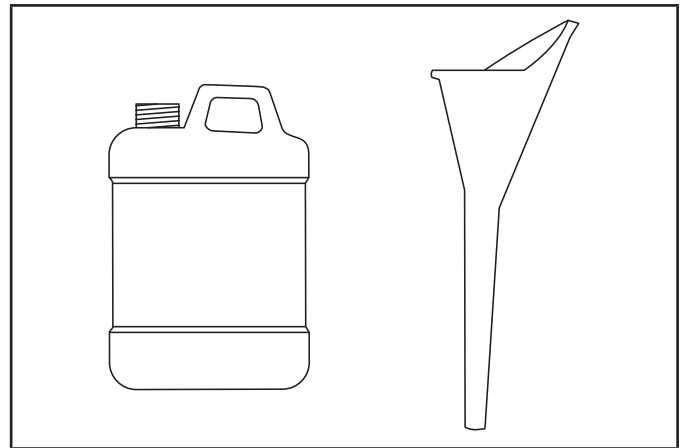

Tools Needed

- Wrench/Socket set (metric)

ASSEMBLY

Your generator requires some assembly. It must be properly serviced with fuel and oil before operation.

Unpacking

1. Set the shipping carton on a solid, flat surface.
2. Remove everything from the carton except the generator.
3. By lifting up on the frame of the unit, carefully remove the generator from the box (two people lifting is recommended).

Remove Shipping Support Spacers

To protect the generator during shipping, support spacers have been installed between the engine and frame. These spacers **MUST BE REMOVED BEFORE** adding oil or gasoline to the generator.

NOTICE

DO NOT attempt to run generator without first removing the shipping support spacers. Damage to the generator as a result of not removing the spacers will void the warranty.

1. **BEFORE** filling the engine with oil or gasoline, tip the generator onto its side as shown. Tip onto the flattened cardboard box the generator came in or other protective surface so as to not scratch the frame.
2. Remove the bolts from the orange support spacers and remove the spacers while lightly lifting the engine. Bolts and spacers can be discarded.

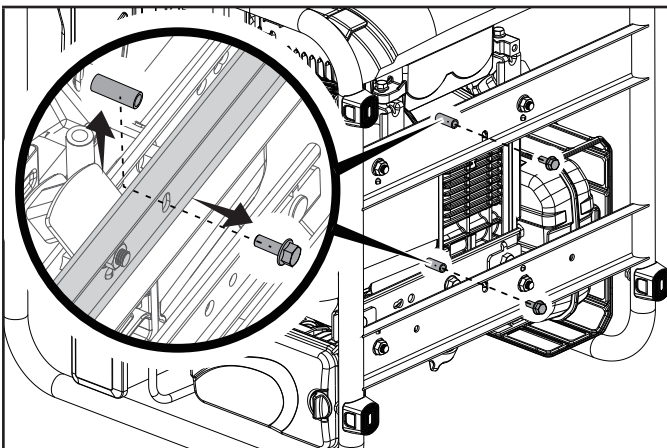

3. Tip the generator upright.

Add Engine Oil

CAUTION

DO NOT attempt to crank or start the engine before it has been properly filled with the recommended type and amount of oil. Damage to the generator as a result of failing to follow these instructions will void your warranty.

NOTICE

The generator rotor has a sealed, pre-lubricated ball bearing that requires no additional lubrication for the life of the bearing.

NOTICE

The recommended oil type for typical use is **10W-30 automotive oil**.

If running generator in extreme temperatures, refer to the following chart for recommended oil type.

		Recommended Engine Oil Type							
		10W-30							
		5W-30				10W-40			
		5W-30 Full Synthetic							
°F		-20	0	20	40	60	80	100	120
°C		-28.9	-17.8	-6.7	4.4	15.6	26.7	37.8	48.9
		Ambient temperature							

1. Place the generator on a flat, level surface.
2. Remove oil fill cap/dipstick to add oil.
3. Using a funnel, add up to 18.6 fl. oz. (550 ml) of oil (included) and replace oil fill cap/dipstick. **DO NOT OVERFILL.**

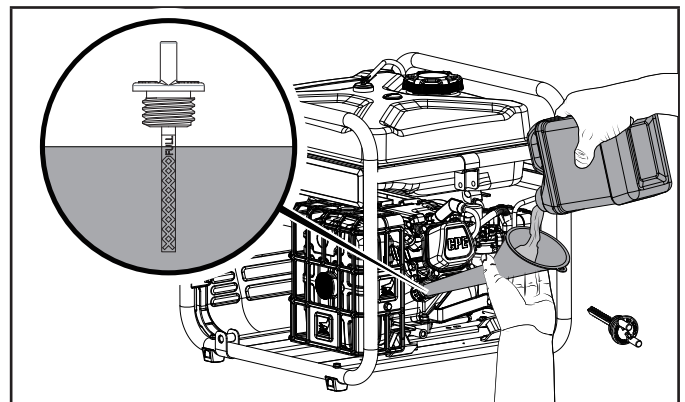

4. Check engine oil level at every use and add as needed.

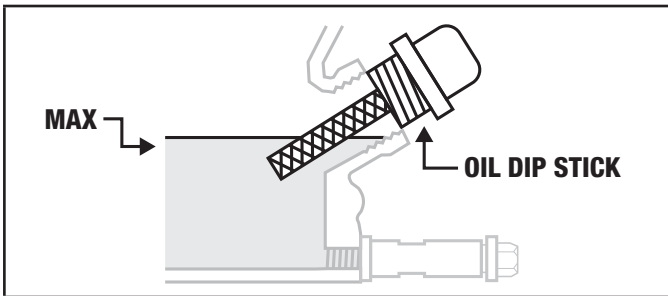

NOTICE

Once oil has been added, a visual check should show oil about 1-2 threads from running out of the fill hole.

When using the dipstick to check oil level, DO NOT screw in the dipstick while checking.

NOTICE

Check oil level often during the break-in period. Refer to the *Maintenance* section for recommended service intervals.

CAUTION

This engine is equipped with a low oil shut-off and will stop when the oil level in the crankcase falls below the threshold level.



NOTICE

The first 5 hours of run time are the break-in period for the unit. During the break in period stay at or below 50% of the running watt rating and vary the load occasionally to allow stator windings to heat and cool. Adjusting the load will also cause engine speed to vary slightly and help seat piston rings. After the 5 hour break-in period, change the oil.

NOTICE

Synthetic oil may be used after the 5 hour initial break-in period. Using synthetic oil does not decrease the recommended oil change interval. Full synthetic 5W-30 oil will aid in starting in cold ambient < 41° F (5° C) temperatures.

Add Fuel

Use clean, fresh, regular unleaded gasoline with a minimum octane rating of 87 and an ethanol content of 10% or less by volume.   

DO NOT mix oil with gasoline.

1. Remove the gasoline cap.

2. Slowly add gasoline to the tank. Tank is full when gasoline reaches red circle on screen. DO NOT OVERFILL. Gasoline can expand after filling. A minimum of ¼ in. (6.4 mm) of space left in the tank is required for gasoline expansion, although more than ¼ in. (6.4 mm) is recommended. Gasoline can be forced out of the tank as a result of expansion if overfilled, and can affect the stable running condition of the generator. The approximate fuel level is shown on the fuel gauge on top of the fuel tank.

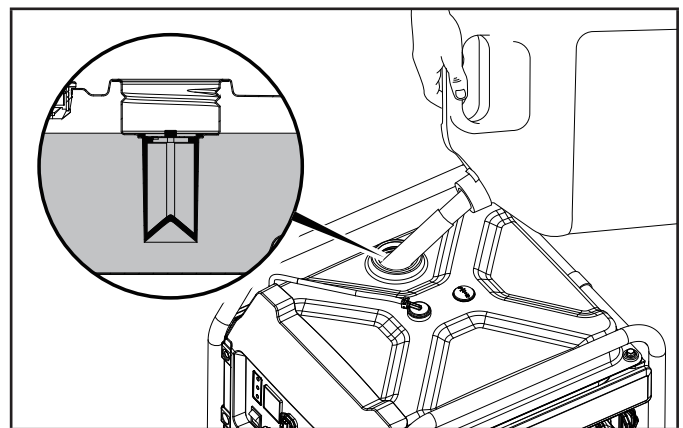

3. Screw on the gasoline cap and wipe away any spilled fuel.

CAUTION

Use unleaded gasoline with a minimum octane rating of 87 and an ethanol content of 10% or less by volume.

DO NOT light cigarettes or smoke when filling the tank.

DO NOT mix oil and gasoline.

DO NOT overfill the tank. Fill tank to approximately ¼ in. (6.4 mm) below the top of the tank to allow for gasoline expansion.

DO NOT pump gasoline directly into the generator at the pump. Use an approved fuel container to transfer the gasoline to the generator.

DO NOT fill tank indoors.

DO NOT fill tank when the engine is running or hot.

WARNING

Pouring gasoline too fast through the fuel screen may result in gasoline splashing over the generator and operator while filling.

NOTICE

The generator engine works well with 10% or less ethanol blend gasoline. When using ethanol-gasoline blends there are some issues worth noting:

- Ethanol-gasoline blends can absorb more water than gasoline alone.
- These blends can eventually separate, leaving water or a watery goo in the tank, fuel valve and carburetor. The compromised gasoline can be drawn into the carburetor and cause damage to the engine and/or potential hazards.
- If a fuel stabilizer is used, confirm that it is formulated to work with ethanol-gasoline blends.
- Any damages or hazards caused by using improper gasoline, improperly stored gasoline, and/or improperly formulated stabilizers, are not covered by manufacturer's warranty.

It is advisable to always shut off the gasoline supply and run the engine to starvation after each use. See Storage instructions for extended non-use.

Grounding

Your generator must be properly connected to an appropriate ground to help prevent electric shock.

WARNING

Failure to properly ground the generator can result in electric shock.

A ground terminal connected to the panel of the generator has been provided (see Controls and Features for terminal location). For remote grounding, connect a length of heavy gauge (12 AWG minimum) copper wire between the generator ground terminal and a copper rod driven into the ground. We strongly recommend that you consult with a qualified electrician to ensure compliance with local electrical codes.

Neutral Floating*

- Neutral circuit **IS NOT** electrically connected to the frame/ground of the generator.
- The generator (stator winding) is isolated from the frame and from the AC receptacle ground pin.
- Electrical devices that require a grounded receptacle pin connection will not function if the receptacle ground pin is not functional.

Neutral Bonded to Frame*

- Neutral circuit **IS** electrically connected to the frame/ground of the generator.
- The generator system ground connects lower frame cross-member below the alternator. The system ground is connected to the AC neutral wire.

*See your Specifications section for specified type of grounding.

OPERATION**Generator Location****WARNING**

NEVER operate the generator inside any building, garage, basement, crawlspace, shed, enclosure or compartment, including a generator compartment of a recreational vehicle.

NEVER operate or start the generator in the back of an SUV, camper, trailer, truck bed (regular sides, flat or other configuration), under staircases, stairwells, next to walls or buildings or in any other location that will not allow for adequate cooling of the generator or for the proper exit of the exhaust flow from the muffler system.

DO NOT operate or store the generator in wet weather conditions such as rain or snow. Using a generator in wet conditions could result in serious injury or death due to electrocution.

In some state's generators may be required to be registered with the local utility company when used at construction sites and may be subject to additional rules and regulations, consult your local municipal authority.

Generators should always be operated on a flat, level surface at all times (even when not in operation).

Generators must have a minimum of 5 feet (1.5 m) of clearance from all combustible material.

Generators must also have a minimum of 3 feet (91.4 cm) of air flow clearance on all sides to allow for adequate performance cooling, maintenance and servicing.

Always place the generator in a well-ventilated area. NEVER place the generator near air intake vents or where exhaust fumes could be drawn into occupied or confined spaces.

Always carefully consider wind and air currents when positioning generator.

Always allow generators to properly cool before transport or for storage purposes.

Failure to follow proper safety precautions may result in personal injury, damage to the generator and void the manufacturer's warranty.

⚠ WARNING

During operation the muffler and exhaust fumes will become hot. If adequate cooling and breathing space are not supplied, or if the generator is blocked or enclosed, temperatures can become extremely heated and may lead to fire.

Surge Protection

Electronic devices, including computers and many programmable appliances use components that are designed to operate within a narrow voltage range and may be affected by momentary voltage fluctuations. While there is no way to prevent voltage fluctuations, you can take steps to protect sensitive electronic equipment.

- Install UL1449, CSA-listed, plug-in surge suppressors on the outlets feeding your sensitive equipment. Surge suppressors come in single- or multi-outlet styles. They're designed to protect against virtually all short-duration voltage fluctuations.

Starting the Engine

1. Make certain the generator is on a flat, level surface.
2. Disconnect all electrical loads from the generator. Never start or stop the generator with electrical devices plugged in or turned on.
3. Turn the fuel valve to the "ON" position.

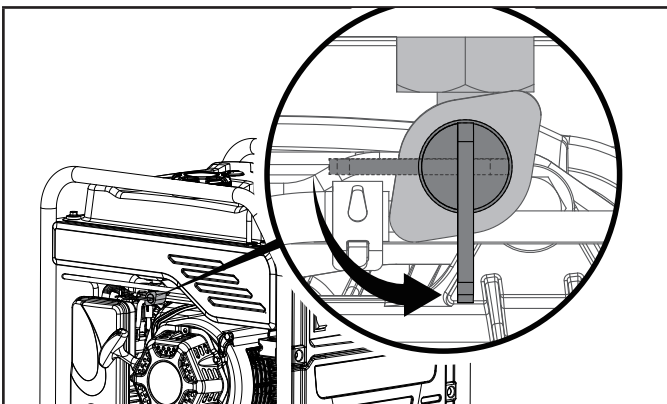

4. Turn the engine switch to the "ON" position.

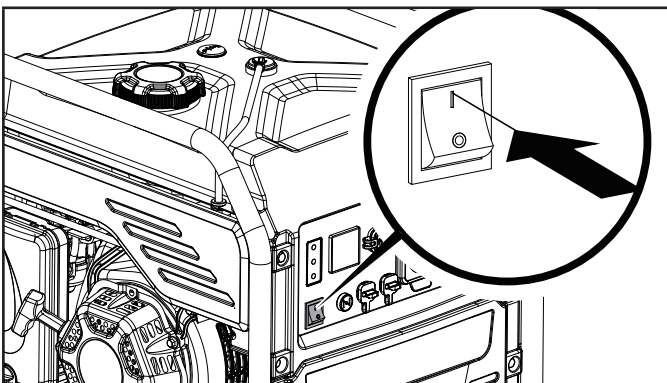

5. Pull choke knob out to the "CHOKE" position.

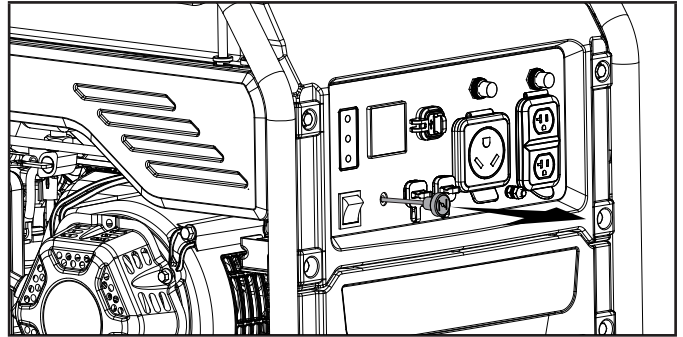

6. Pull the recoil cord slowly until resistance is felt and then pull rapidly.

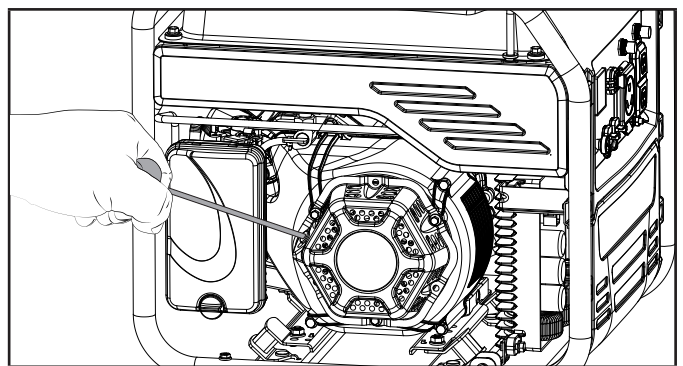

7. As engine warms up, push the choke knob in to the "RUN" position.

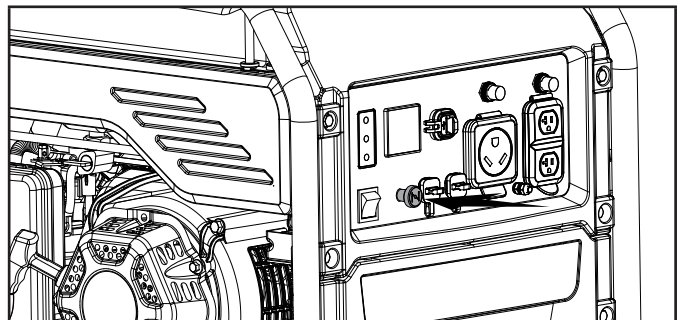

🗨 NOTICE

Keep choke in "CHOKE" position for only 1 pull of the recoil cord. After first pull, press the choke knob in to the "RUN" position for up to the next 3 pulls of the recoil cord. Too much choke leads to spark plug fouling/engine flooding due to the lack of incoming air. This will cause the engine not to start.

NOTICE

For gasoline restarts with hot engine in hot ambient > 86°F (30°C): Keep the choke in 75% of the “CHOKE” position for only 1 pull of the recoil cord. After first pull, push choke to the “RUN” position for up to 3 more pulls of the recoil cord. Too much choke leads to spark plug fouling/engine flooding due to the lack of incoming air. This will cause the engine not to start.

NOTICE

For gasoline starting in cold ambient < 59°F (15°C): The choke must be in 100% of the “CHOKE” position for manual start procedures. Do not over-choke. As soon as engine starts, push the choke knob in the “RUN” position.

NOTICE

If the engine starts but does not continue to run make certain that the generator is on a flat, level surface. The engine is equipped with a low oil sensor that will prevent the engine from running when the oil level falls below a critical threshold.

Connecting Electrical Loads

Let the engine stabilize and warm up for a few minutes after starting.

Plug in and turn on the desired 120 or 240 (if applicable) Volt AC single phase, 60 Hz electrical loads.

- DO NOT connect 3-phase loads to the generator.
- DO NOT overload the generator.

WARNING

Always remember to plug your appliances directly into the generator and do not plug the generator power cord into any electrical outlet or connect to the circuit breaker panel in your home. Connecting a generator to your home's electric utility company's power lines, or to another power source, called 'backfeeding' is a dangerous practice that is illegal in many states and municipalities.

This action if done incorrectly could damage your generator, appliances and could cause serious injury or death to you or a utility worker when attempting to restore power during an outage occurrence in the neighborhood who may then unexpectedly encounter high voltage on the utility line and suffer a fatal shock.

Whether injuries occur or not, if installed incorrectly and not to applicable laws and codes, you may be subject to fines or the utility company may disconnect your home power should this practice be found in your home.

If the generator will be connected to a building electrical system, those connections must isolate the generator power from the utility power. You are responsible for ensuring your generator's electricity does not backfeed into the electric utility power lines. These connections must comply with all applicable laws and codes – Consult your local utility company or a qualified electrician to properly install this connection.

Do Not Overload Generator

Capacity

Follow these simple steps to calculate the running and starting watts necessary for your purposes:

1. Select the electrical devices you plan on running at the same time.
2. Total the running watts of these items. This is the amount of power you need to keep your items running.
3. Identify the highest starting wattage of all devices identified in step 1. Add this number to the number calculated in step 2. Starting wattage is the surge of power needed to start some electric driven equipment. Following the steps listed under “Power Management” will guarantee that only one device will be starting at a time.

Power Management

Use the following formula to convert voltage and amperage to watts:

$$\text{Volts} \times \text{Amps} = \text{Watts}$$

To prolong the life of your generator and attached devices, follow these steps to add electrical load:

1. Start the generator with no electrical load attached.
2. Allow the engine to run for several minutes to get up to temperature.
3. Plug in and turn on the first item. It is best to attach the item with the largest load first.
4. Allow the engine to stabilize.
5. Plug in and turn on the next item.
6. Allow the engine to stabilize.
7. Repeat steps 5-6 for each additional item.

NOTICE

Never exceed the specified capacity when adding loads to the generator.

Eco (Economy) Mode

The Eco Mode button can be activated to turn on economy control in order to minimize fuel consumption and noise while operating the unit during times of reduced electrical output. Eco Mode allows the engine speed to idle during periods of non-use.

The engine speed returns to normal when an electrical load is connected. When the economy switch is off, the engine runs at normal speed continuously.

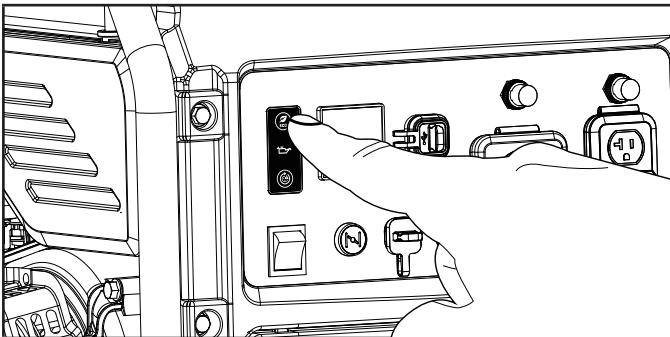

CAUTION

For periods of high electrical load or momentary fluctuations, the Eco Mode should be off.

Parallel Operation

The Champion model 200955 is parallel ready and can be operated in parallel with another Champion unit to increase the total available electrical power. A Champion model 100319 parallel kit (sold separately) is required for parallel operation.

Detailed instructions for parallel kit installation and operation of the connected generators are provided in the parallel kit operator's manual.

Stopping the Engine

1. Turn off and unplug all electrical loads. Never start or stop the generator with electrical devices plugged in or turned on.
2. Let the generator run at no-load for several minutes to stabilize internal temperatures of the engine and generator.
3. Turn the fuel valve to the "OFF" position.

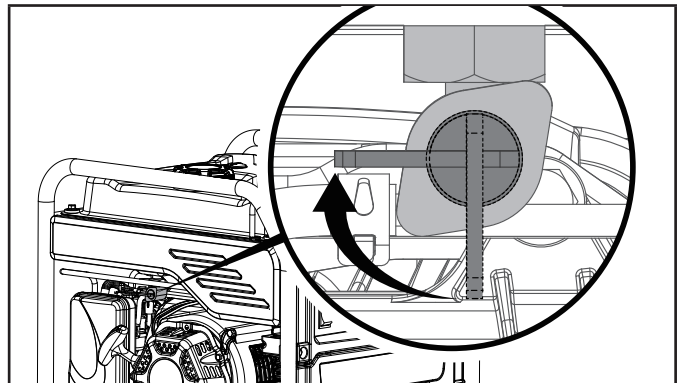

4. Let the engine run until fuel starvation has stopped the engine. This usually takes a few minutes.
5. Press the engine switch to the "OFF" position.

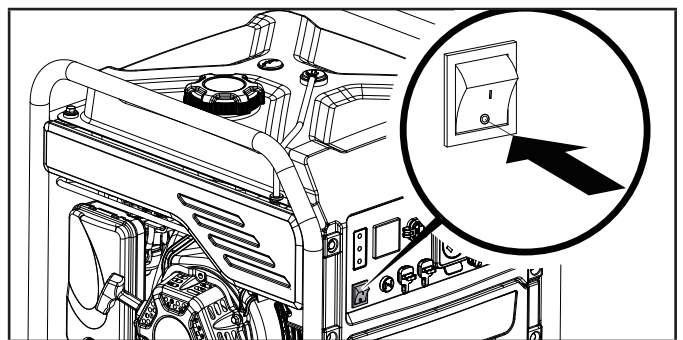

Important: Always ensure that the fuel valve and the engine switch are in the "OFF" position when the generator is not in use.

NOTICE

If the engine will not be used for a period of two (2) weeks or longer, please see the Storage section for proper engine and fuel storage.

Moving the Generator

- ALWAYS turn the generator off and ensure the fuel valve is closed.
- ALWAYS make sure engine and muffler are cooled down before the generator can be handled safely (typically 15-30 minutes).
- Lift unit up by the frame and move to the desired location.
- Do not drop or strike unit or place under heavy objects.
- Failure to follow these instructions could result in personal injury or damage to the generator.

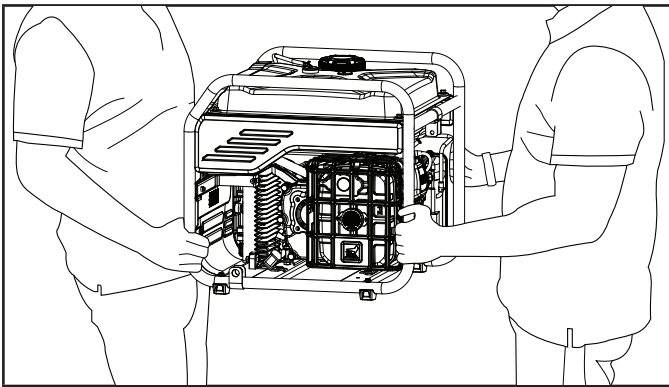

Operation at High Altitude

The density of air at high altitudes is lower than at sea level. Engine power is reduced as the air mass and air-fuel ratio decrease. Engine power and generator output will be reduced approximately 3½% for every 1000 ft. of elevation above sea level. At high altitudes increased exhaust emissions can also result due to the increased enrichment of the air fuel ratio. Other high altitude issues can include hard starting, increased fuel consumption and spark plug fouling.

To alleviate high altitude issues other than the natural power loss, CPE can provide a high altitude carburetor main jet. The alternative main jet and installation instructions can be obtained by contacting our Technical Support Team. Installation instructions are also available in the Technical Bulletin area of the CPE website.

The part number and recommended altitude range for the application of the high altitude carburetor main jet is listed in the following table.

In order to select the correct high altitude main jet it is necessary to identify the carburetor model. For this purpose, a code is stamped on the side of the carburetor. Select the correct high altitude jet part number corresponding to the carburetor code found on your particular carburetor.

Carb. Code	High Alt. Jet Part Number	Altitude Range
19694	100005757	3281 ft. (1000 m)
	100005766	6562 ft. (2000 m)

⚠ WARNING

Operation using the alternative main jet at elevations lower than the recommended minimum altitude can damage the engine. For operation at lower elevations, the originally supplied standard main jet must be used. Operating the engine with the wrong engine configuration at a given altitude may increase its emissions and decrease fuel efficiency and performance.

MAINTENANCE

Make certain that the generator is kept clean and stored properly. Only operate the unit on a flat, level surface in a clean, dry operating environment. DO NOT expose the unit to extreme conditions, excessive dust, dirt, moisture or corrosive vapors.

⚠ WARNING

Never operate a damaged or defective generator.

⚠ WARNING

Improper maintenance will void your warranty.

🗨 NOTICE

For Emission control devices and systems, read and understand your responsibilities for service as stated in the Emission Control Warranty Statement of this manual.

The owner/operator is responsible for all periodic maintenance. Complete all scheduled maintenance in a timely manner. Correct any issue before operating the generator.

Cleaning the Generator

⚠ CAUTION

DO NOT spray generator directly with water.

Water can enter the generator through the cooling slots and damage the generator windings. It can also contaminate the fuel system.

1. Use a damp cloth to clean exterior surfaces of the generator.
2. Use a soft bristle brush to remove dirt and oil.
3. Use an air compressor (25 PSI) to clear dirt and debris from the generator.

- Inspect all air vents and cooling slots to ensure that they are clean and unobstructed.

To prevent accidental starting, remove and ground the spark plug wire before performing any service.

Changing the Engine Oil

Change oil when the engine is warm. Refer to the oil specification to select the proper grade for your operating environment.

- While holding the flat part of the drain tube with pliers or wrench, remove the oil drain bolt with a 10 mm socket (not included) or wrench.

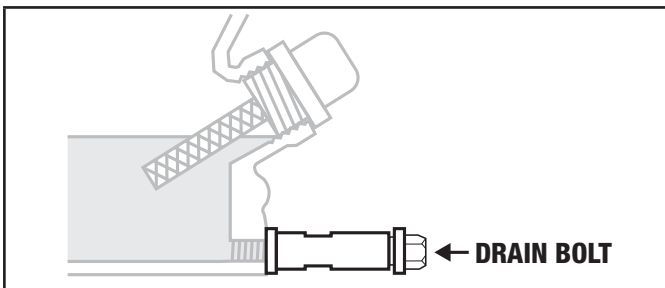

- Allow the oil to drain completely into an appropriate container.

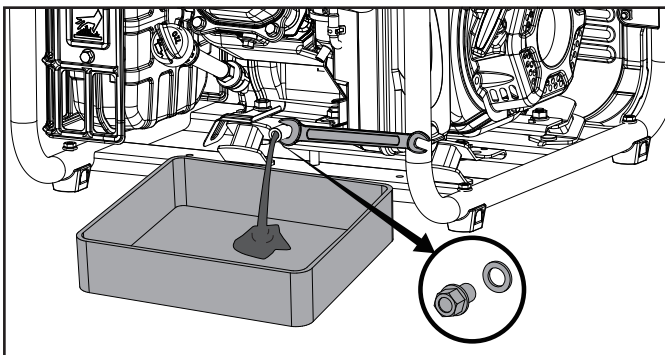

- Replace the oil drain bolt.
- Add oil according to *Add Engine Oil* in *Assembly* section. **DO NOT OVERFILL.** Oil not included for routine maintenance.
- Dispose of used oil at an approved waste management facility.

NOTICE

Once oil has been added, a visual check should show oil about 1-2 threads from running out of the fill hole. If using the dipstick to check oil level, **DO NOT** screw in the dipstick while checking.

Cleaning and Adjusting the Spark Plug

- Remove the spark plug cable from the spark plug.
- Use a spark plug socket tool (not included), or a 13/16 in. (21 mm) socket (not included) to remove the plug.

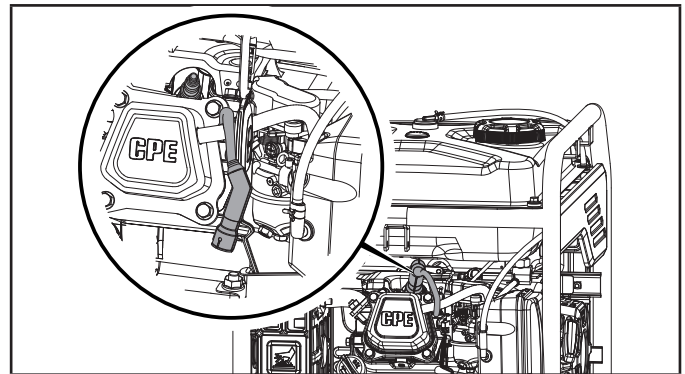

- Inspect the electrode on the plug. It must be clean and not worn to produce the spark required for ignition.
- Make certain the spark plug gap is 0.024-0.031 in. (0.6-0.8 mm).

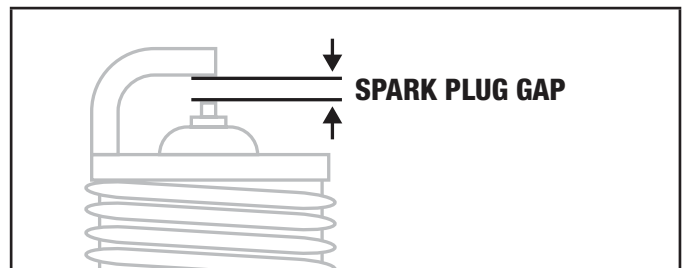

- Refer to the spark plug types in *Specifications* when replacing the plug.
- Firmly re-install the plug.
- Attach the spark plug cable to the spark plug.

Cleaning the Air Filter

- Unscrew the cover holding the air filter to the assembly by turning the fastener counterclockwise.

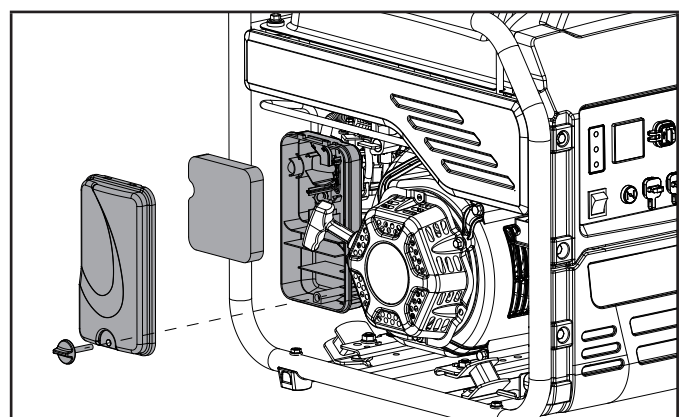

- Remove the foam element.

3. Wash in liquid detergent and water. Squeeze thoroughly dry in a clean cloth.
4. Saturate in clean engine oil.
5. Squeeze in a clean, absorbent cloth to remove all excess oil.
6. Place the filter in the assembly.
7. Reattach the air filter cover and tighten the fastener by turning clockwise.

Cleaning the Spark Arrestor

1. Allow the engine to cool completely before servicing the spark arrestor.
2. Remove the two screws holding the cover plate which retains the spark arrestor to the muffler.
3. Remove the spark arrestor screen.
4. Carefully remove the carbon deposits from the spark arrestor screen with a wire brush.

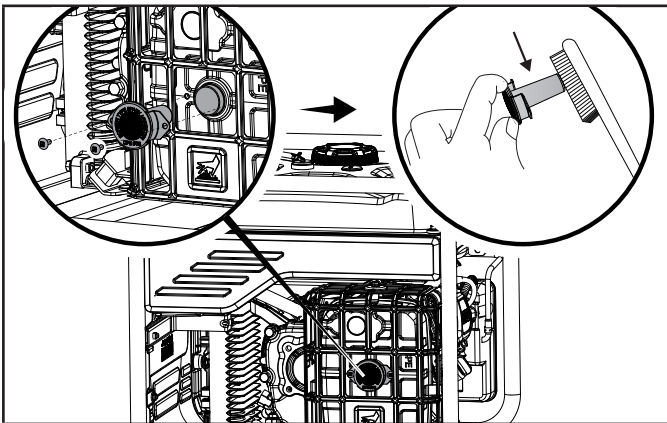

5. Replace the spark arrestor if it is damaged.
6. Position the spark arrestor on the muffler and attach with the screws removed in step 2.

CAUTION

Failure to clean the spark arrestor will result in degraded engine performance.

NOTICE

Federal and local laws and administrative requirements indicate when and where spark arrestors are required. When ordered, spark arrestors are required for operation of this generator in National Forest lands. In California, this generator must not be used on any forest-covered land, brush-covered land, or grass-covered land unless the engine is equipped with a spark arrestor.

Adjusting the Governor

WARNING

Tampering with the factory set governor will void your warranty.

The air-fuel mixture is not adjustable. Tampering with the governor can damage your generator and your electrical devices and will void your warranty.

Maintenance Schedule

Follow the service intervals indicated in the following maintenance schedule.

Service your generator more frequently when operating in adverse conditions.

EVERY 8 HOURS OR PRIOR TO EACH USE

- Check oil level
- Clean around air intake and muffler

FIRST 5 HOURS (BREAK IN)

- Change oil

EVERY 50 HOURS OR ANNUALLY

- Clean air filter
- Change oil if operating under heavy load or in hot environments

EVERY 100 HOURS OR ANNUALLY

- Change oil
- Clean/adjust spark plug
- Clean spark arrestor
- Clean fuel valve filter*

EVERY 250 HOURS

- Clean combustion chamber*
- Check/adjust valve clearance*

EVERY 3 YEARS

- Replace fuel line*

*To be performed by knowledgeable, experienced owners or CPE certified service centers.

STORAGE

⚠ DANGER

Gasoline vapors are highly flammable and extremely explosive.

DO NOT light or smoke cigarettes. Fire or explosion can cause severe burns or death.

Only fill or drain fuel outdoors in a well-ventilated area.
DO NOT pump gasoline directly into the generator. Use an approved container to transfer the fuel to the generator.

Never use a gasoline container, gasoline tank, or any other fuel item that is broken, cut, torn or damaged.

DO NOT overfill the gasoline tank. Always keep fuel away from sparks, open flames, pilot lights, heat and other sources of ignition.

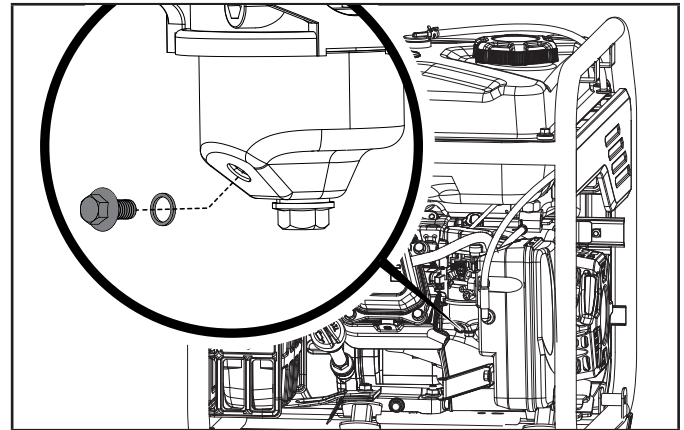

5d. When gasoline stops flowing from the carburetor, replace and tighten the carburetor drain bolt and be sure to properly dispose of the drained gasoline according to local regulations or guidelines.

6. Option 2: Run Dry

6a. With the generator running, turn the fuel valve to the “OFF” position and allow the generator to run until the engine stops from complete fuel starvation. This may take a few minutes.

6b. Turn engine switch to the “OFF” position and allow generator to cool completely before continuing.

7. Remove the spark plug cap and spark plug and pour about a tablespoon of oil into the cylinder.
8. Pull the recoil cord slowly to crank the engine to distribute the oil and lubricate the cylinder.
9. Install the spark plug and spark plug cap.
10. Clean the generator according to *Cleaning the Generator*.
11. Store the generator in a cool, dry place out of direct sunlight.

Short Term Storage (up to 30 days)

Gasoline may gum up and clog the carburetor if the generator is not run or carburetor drained within 4 weeks.

1. Be sure all appliances are disconnected from the generator.
2. Start the generator as instructed in *Starting the Engine* section.
3. Turn the fuel valve to the “OFF” position.
4. Let the engine run until fuel starvation has stopped the engine. This usually takes a few minutes.
5. Move the engine switch to the “OFF” position.

Mid Term Storage (30 days – 1 year)

Gasoline in the tank has a maximum shelf life of up to 1 year with the addition of a properly formulated fuel stabilizer and stored in a cool, dry place.

1. Be sure all appliances are disconnected from the generator.
2. Add a properly formulated fuel stabilizer to the gasoline tank.
3. Turn the fuel valve to the “ON” position.
4. Start and run the generator for 10 minutes so the treated gasoline cycles through the fuel system.
5. **Option 1: Drain Gasoline from Carburetor**

5a. Turn engine switch to the “OFF” position and allow generator to cool completely before continuing.

5b. Turn the fuel valve to the “OFF”.

5c. Use the drain bolt on the carburetor to empty any excess gasoline from the carburetor into an appropriate container. Use a funnel (and appropriate hose if necessary) under the carburetor drain bolt to avoid spillage.

Long Term Storage (over 1 year)

For storage over 1 year, the gasoline tank and carburetor must be completely drained of gasoline.

1. The generator is to be OFF and all appliances disconnected.
2. Turn the fuel valve to the “ON” position.
3. Use the drain bolt on the carburetor to empty any excess gasoline from the gasoline tank and carburetor into an appropriate container. Use a funnel (and appropriate hose if necessary) under the carburetor drain bolt to avoid spillage.
4. When gasoline stops flowing from the carburetor, replace and tighten the carburetor drain bolt and be sure to properly dispose of the drained gasoline according to local regulations or guidelines.
5. Turn the fuel valve to the “OFF” position.
6. Follow steps 7-11 according to *Mid Term Storage*.

Removing from Storage

If the generator has been improperly stored for a long period of time with gasoline in the gasoline tank and/or carburetor, all fuel must be drained and the carburetor must be thoroughly cleaned. This process involves technically advanced tasks.

If the gasoline tank and carburetor were properly emptied of all gasoline prior to the generator being stored, follow the below steps when removing from storage.

1. Be sure the engine switch is in the "OFF" position.
2. Add gasoline to the generator according to *Add Fuel*.
3. Turn the fuel valve to the "ON" position.
4. After 5 minutes check the carburetor and air filter areas for any leaking gasoline. If any leaks are found, the carburetor will need to be disassembled and cleaned or replaced. If no gasoline leaks are found, turn the fuel valve to the "OFF" position.
5. Check engine oil level and add clean, fresh oil if needed. See *Oil Specifications* for proper oil type.
6. Check and clear air filter of any obstructions such as bugs or cobwebs. If necessary, clean air filter according to *Cleaning the Air Filter*.
7. Start the generator according to *Starting the Engine*.

SPECIFICATIONS

Generator Specifications

Generator Model	200955
Start Type	Manual
Watts (Starting/Running)	4250/3500
Volts AC	120
AC Amps @ 120V	29.2
Volts DC	5
DC Amps	2.1
Frequency	60 Hz
Phase	Single
Grounding Type	Neutral Floating
Weight	75 lb. (34 kg)
Length	20.9 in. (53.2 cm)
Width	18.3 in. (46.6 cm)
Height	19.4 in. (49.4 cm)

Engine Specifications

Model	GB225-2
Displacement	224 cc
Type	4-Stroke OHV

Spark Plug

OEM Type	F6RTC
Replacement Type	NGK BPR6ES or equivalent
Gap	0.024-0.031 in. (0.6-0.8 mm)

Valve

Intake Clearance	0.004-0.006 in. (0.10-0.15 mm)
Exhaust Clearance	0.006-0.008 in. (0.15-0.20 mm)

Oil Specifications

DO NOT OVERFILL.

Type	*See following chart
Capacity	18.6 fl. oz. (550 ml)

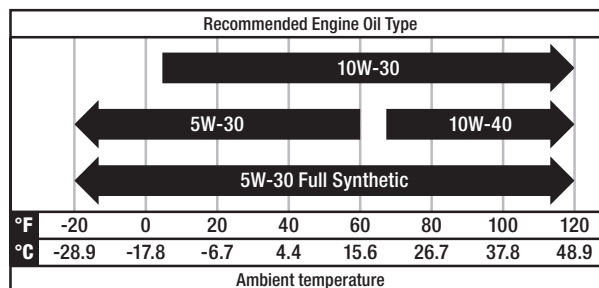

NOTICE

Temperature will affect engine oil and engine performance. Change the type of engine oil used based on the temperature shown in the *Recommended Engine Oil Type* table.

Fuel Specifications

Use unleaded gasoline with a minimum octane rating of 87 and an ethanol content of 10% or less by volume. DO NOT USE E15 or E85. DO NOT OVERFILL.

Gasoline Capacity	4 gal. (15.2 L)
-------------------------	-----------------

Temperature Specifications

Starting Temperature Range (°F/°C)	5 to 104/-15 to 40
--	--------------------

NOTICE

An important message about temperature: Your product is designed and rated for continuous operation at ambient temperatures up to 104°F (40°C). When needed, it may be operated at temperatures ranging from 5°F (-15°C) to 122°F (50°C) for short periods of time. If exposed to temperatures outside this range during storage, it should be brought back within this range before operation. In any event, the product must always be operated outdoors, in a well-ventilated area and away from doors, windows and vents.

Parts Diagram

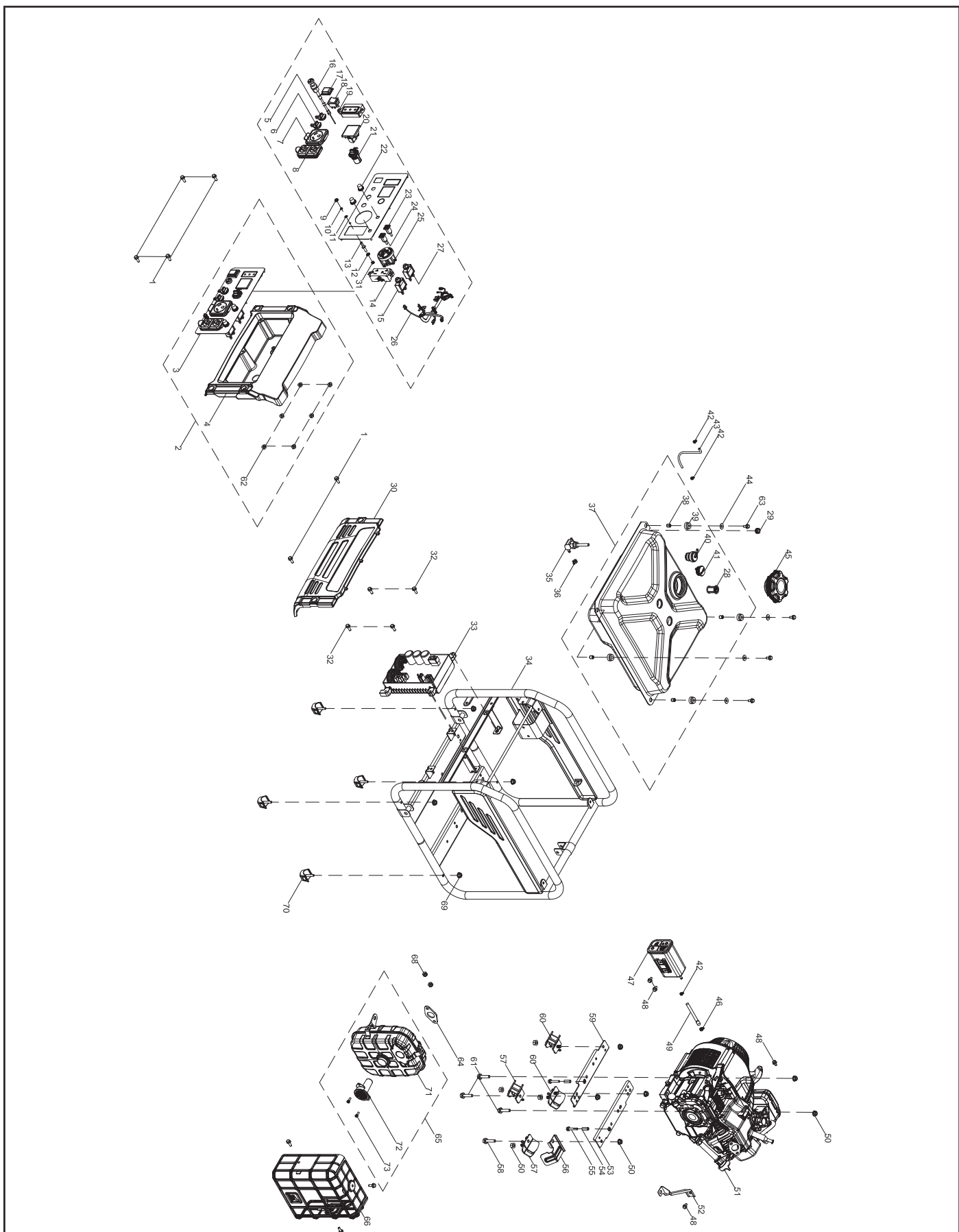

Parts List

#	Part Number	Description	Qty.
1	100011264-0002	Flange Bolt M6 × 16	6
2	100714115-0001	Panel Assembly	1
3	100715566	Control Panel	1
4	100142006-0002	Protect Panel	1
5	100150096-0001	Cover, Parallel Terminal, Red	1
6	100150096-0002	Cover, Parallel Terminal, Black	1
7	100088268	Receptacle Cover, TT-30R	1
8	100098921	Receptacle Cover, 5-20R, Duplex	1
9	100011421-0002	Flange Nut M6	1
10	100010886-0002	Spring Washer Ø6	1
11	100010910-0002	Washer Ø6	1
12	100011025-0001	Lock Washer Ø6, Toothed	1
13	100092320-0002	Ground Stud	1
14	100020029	Receptacle 5-20R, Duplex	1
15	100019747	20Amp Circuit Breaker, Push Button	1
16	100154334	Cable	1
17	100126120	Switch Cover	1
18	100019760-0001	Switch	1
19	100152493	LED Display Module	1
20	100710623	Intelligauge, VFT-2	1
21	100714740	Dual USB Receptacle	1
22	100120180	Cover, Circuit Breaker	2
23	100091059-0001	Parallel Terminal, Red	1
24	100091059-0002	Parallel Terminal, Black	1
25	100020008	Receptacle TT-30R	1
26	100715127	Wire harness Assembly	1
27	100019756	30Amp Circuit Breaker, Push Button	1
28	100098838	Fuel Filter	1
29	100009075	Sheath, Connection Tube	1
30	100142007-0002	Protective Cover, Inverter Module	1
31	100011419-0003	Flange Nut M5	1
32	100011268-0003	Flange Bolt M6 × 25, GB5789	4
33	100710871	Inverter Module, 120V 60Hz	1

#	Part Number	Description	Qty.
34	100142008-0001	Frame 530 × 453 × 480	1
35	100136320	Fuel Valve	1
36	100005138	Clamp Ø9.5 × 8	1
37	100142005-0003	Fuel Tank, 15.2 L, Black	1
38	100715500	Bushing, Ø9 × Ø6.6 × 10	4
39	100711813	Vibration Mounting, Fuel Tank	4
40	100099571	Reversal Valve	1
41	100153185	Fuel Gauge	1
42	100005148	Clamp Ø8	3
43	100152501	Connection Tube 2, 475 mm	1
44	100010437-0001	Washer Ø6.5 × 1.5 × Ø18.2	4
45	100142004	Fuel Tank Cap	1
46	100005159	Clamp Ø10.5 × 8	1
47	100157588	Carbon Canister, 320 cc	1
48	100011260-0005	Flange Bolt M6 × 10, GB5789	4
49	100155508	Connection Tube 1, 475 mm	1
50	100079483-0001	Flange Nut M8	10
51	1ZC7DFA17	Engine, 224 cc	1
52	100158476	Holder, Air Cleaner	1
53	100162855	Engine Front Board	1
54	100004221-0001	Bushing, Ø6.5 × Ø10 × 24	2
55	100011224-0002	Flange Bolt M6 × 35	2
56	100162980	Insulator	1
57	100093523	Vibration Mount, Support 2	2
58	100011327-0001	Flange Bolt M8 × 43	1
59	100162854	Engine Rear Board	1
60	100093524	Vibration Mount, Support 1	2
61	100011320-0002	Flange Bolt M8 × 35	3
62	100011446-0001	Flange Nut M4	6
63	100011267-0002	Flange Bolt M6 × 22	4
64	100058175	Gasket, Muffler, Graphite	1
65	100151975	Exhaust Muffler Assembly	1
66	100142015-0001	Muffler Cover	1
67	100097575-0002	Flange Bolt M6 × 10	3

#	Part Number	Description	Qty.
68	100011422-0004	Flange Nut M8, GB6170	2
69	100011452-0002	Flange Nut M6, GB6177.1	4
70	100093522	Damping Pad	4
71	100151976	Muffler	1
72	100154368	Spark Arrester Assembly	1
73	100718327	Mounting Bolt, Spark Arrester	2

Engine Parts Diagram

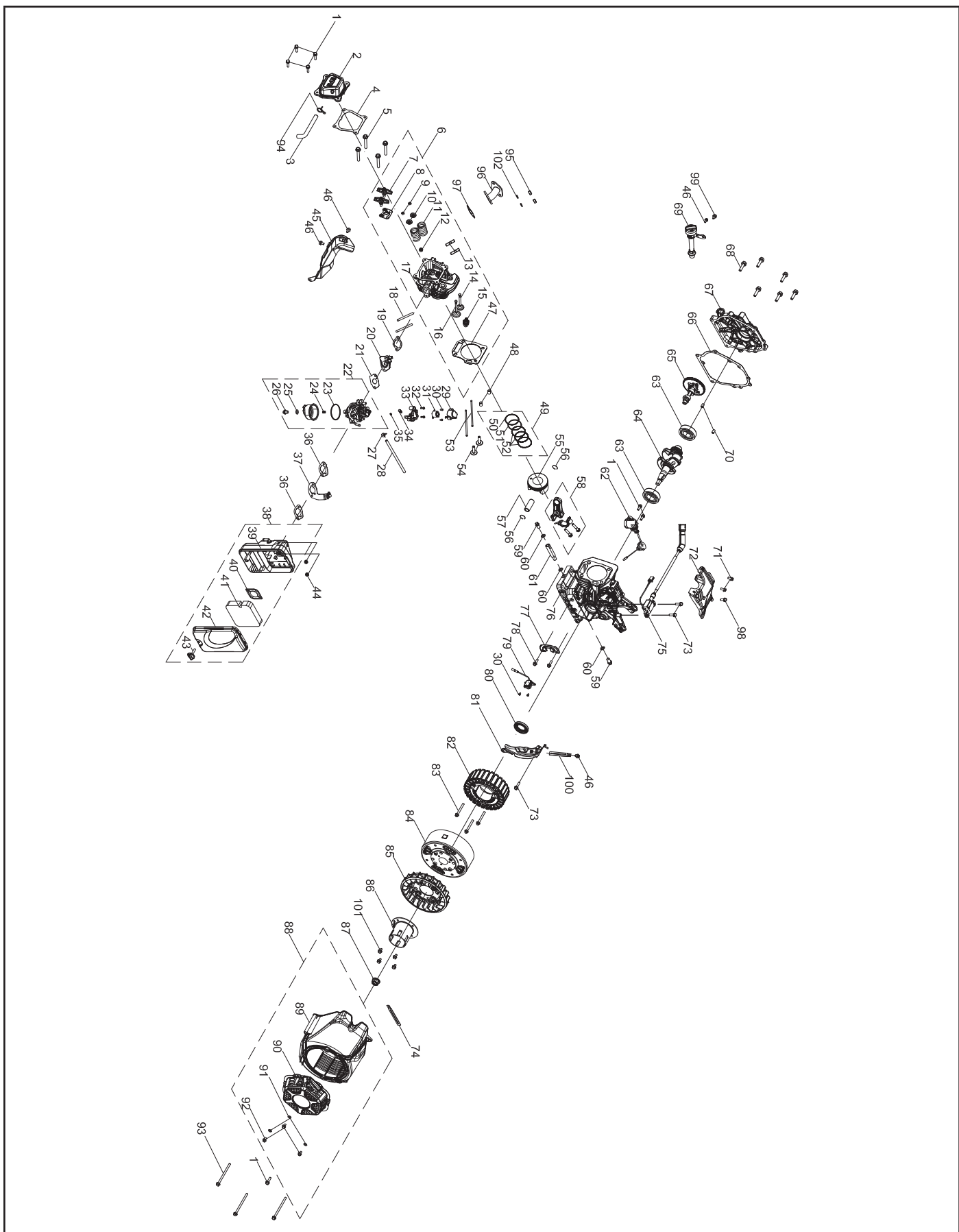

Engine Parts List

#	Part Number	Description	Qty.
1	100011264-0003	Flange Bolt M6 × 16, GB5789	7
2	100002335	Cylinder Head Cover(Cpe)	1
3	100075045	Breather Tube	1
4	100066138	Gasket, Cylinder Head Cover	1
5	100002464-0001	Flange Bolt M8 × 60	4
6	100159588	Cylinder Head Assembly	1
7	100149239	Rocker Arm Assembly	2
8	100050881	Guide Plate, Push Rod	1
9	100050896	Valve Collet	4
10	100073758	Valve Spring Seat, Exhaust	2
11	100713979	Spring Valve	2
12	100004599	Oil Seal, Valve	1
13	100010387	Stud Bolt M8 × 34	2
14	100713981	Exhaust Valve	1
15	100009378	Spark Plug F6RTC	1
16	100713980	Intake Valve	1
17	100079792	Cylinder Head	1
18	100061091	Stud Bolt M6 × 98	2
19	100078607	Gasket, Insulator	1
20	100122101	Insulator, Carburetor	1
21	100078606	Gasket, Carburetor	1
22	100153290	Carburetor	1
23	100005717	Fuel Bowl O-Ring	1
24	100005750	Main Jet Standard	1
	100005757	Main Jet Altitude 1000-2000m	
	100005766	Main Jet Altitude 2000-3000m	
25	100006037	Fuel Bowl Mounting Bolt Gasket	1
26	100005725	Fuel Bowl Mounting Bolt	1
27	100005138	Clamp	1
28	100017831	Fuel Pipe, Ø4 × Ø10 × 126	1
29	100050035	Protection Cover	1
30	100051029-0004	Screw M4 × 6	4
31	100093486	Stepping Motor	1
32	100010947-0001	Screw M4 × 12	2
33	100158241	Stepping Motor Seat	1
34	100033258	Clamp, Stepping Motor Guide	1
35	100052405	Spring	1
36	100713488	Gasket, Air Filter Base	2

#	Part Number	Description	Qty.
37	100142011	Choke Lever Rack	1
38	100153222	Air Filter Assembly	1
39	100156312	Air Filter Base	1
40	100005078	Air Filter Baffle	1
41	100004771	Air Filter Element	1
42	100087055	Air Filter Cover	1
43	100004949	Air Filter Bolt	1
44	100011463-0002	Flange Nut M6	2
45	100007083	Air Guide, Lower	1
46	100011260-0005	Flange Bolt M6 × 10	4
47	100155656	Gasket, Cylinder Head	1
48	100010558	Dowel Pin Ø10 × 16	2
49	100003243	Piston Ring Set	1
50	100072134	1st Piston Ring	1
51	100072135	2nd Piston Ring	1
52	100072136	Oil Ring	1
53	100149269	Push Rod	2
54	100149234	Lifter, Valve	2
55	100003086	Piston	1
56	100003221	Circlip	2
57	100003123	Wrist Pin	1
58	100003446	Connecting Rod Assembly	1
59	100010272	Drain Bolt, M10 × 1.25 × 15	2
60	100010459	Washer Ø10 × 1.5 × Ø16	3
61	100002910-0001	Drain Tube	1
62	100163603	Oil Level Sensor	1
63	100010761	Bearing, TM6205	2
64	100126476	Crankshaft	1
65	100099599	Camshaft	1
66	100010148	Gasket, Crankcase Cover	1
67	100128008	Cover, Crankcase	1
68	100011319-0001	Flange Bolt M8 × 32	6
69	100152738-0001	Oil Dipstick Assembly	1
70	100010550	Dowel Pin Ø8 × 14	2
71	100011215-0001	Flange Bolt M6 × 12	2
72	100122168	Control Assembly	1
73	100011266-0004	Flange Bolt M6 × 20	3
74	100000655	Wire Clip B	1
75	100163601	Ignition Module	1
76	100149610	Crankcase	1
77	100122099	Trigger Support	1
78	100055591-0007	Flange Bolt M6 × 12, GB16674	2

#	Part Number	Description	Qty.
79	100163602	Trigger	1
80	100017644	Oil Seal Ø25 × Ø41.25 × 6	1
81	100130948	Lower Guard	1
82	100153854	Stator Assembly, Fe, Ø156 × 35 mm	1
83	100011540-0007	Flange Bolt M6 × 50	3
84	100126953	Rotor Assembly, Permanent Magneto, Ø180 × 64 mm	1
85	100087582	Cooling Fan	1
86	100087581	Pulley, Starter	1
87	100011459-0003	Flange Nut M14 × 1.5	1
88	100153289-0003	Recoil Starter Assembly	1
89	100128650-0001	Fan Cover, Black	1
90	100156547-0001	Recoil Starter, Black	1
91	100010894-0002	Washer Ø6	3
92	100011565-0002	Flange Bolt M6 × 10, GB16674.1	3
93	100011284-0003	Flange Bolt M6 × 100	3
94	100005152	Clamp Ø11.5	1
95	100011422-0004	Flange Nut M8, GB6170	2
96	100142016	Exhaust Pipe	1
97	100006526	Gasket, Muffler	1
98	100055588-0006	Flange Bolt M6 × 20, GB16674	1
99	100011263-0002	Flange Bolt M6 × 15	1
100	100062546	Wire Clip B	1
101	100011581-0001	Flange Bolt M6 × 14	4
102	100010887-0004	Spring Washer Ø8	2

Wiring Diagram

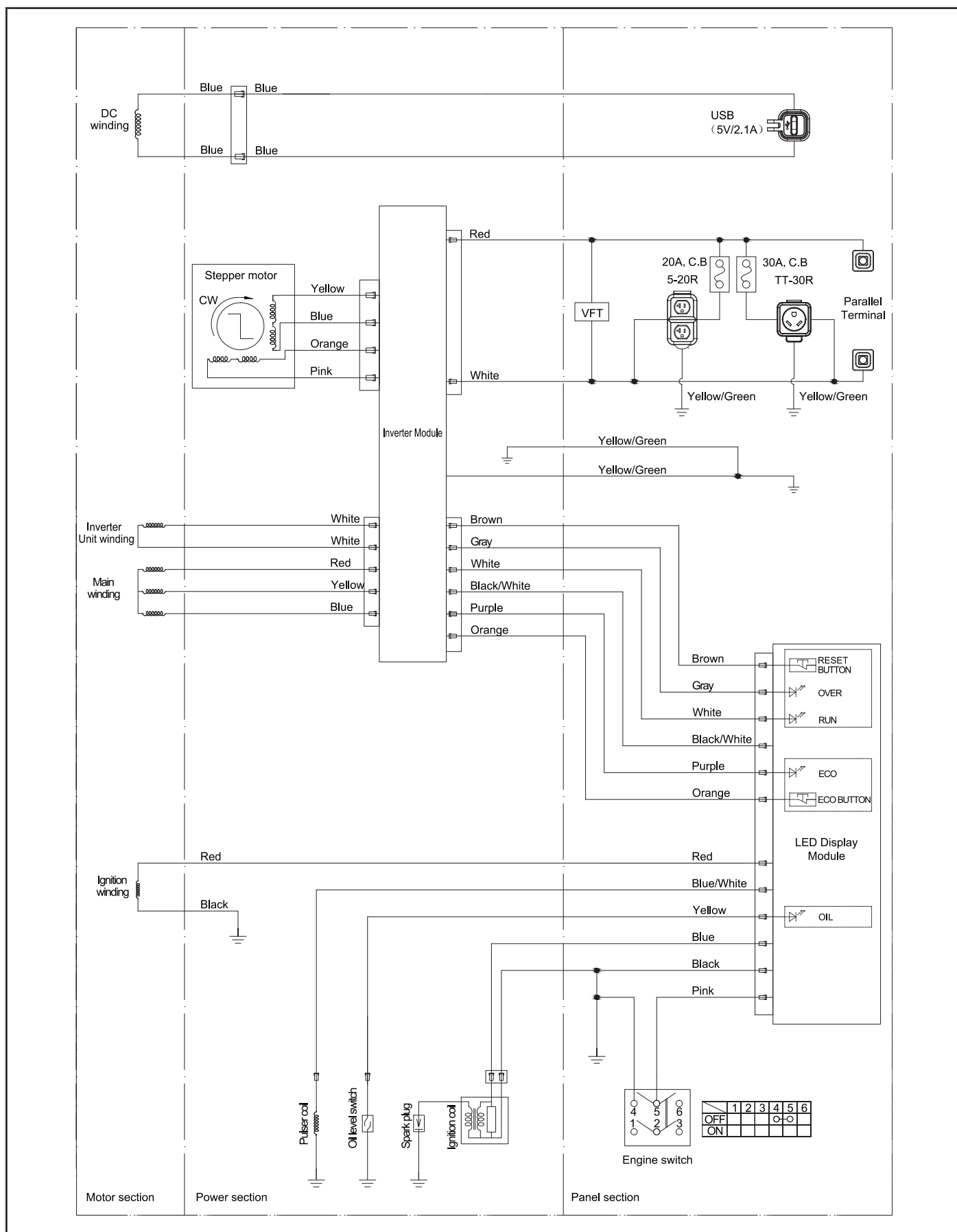

TROUBLESHOOTING

Problem	Cause	Solution
Engine will not start.	No fuel.	Add fuel.
	Faulty spark plug.	Clean and adjust spark plug or replace.
	Low oil level.	Fill crankcase to the proper level.
		Place generator on a flat, level surface.
	Spark plug wire loose.	Attach wire to spark plug.
	Fuel valve is closed.	Open fuel valve.
	Engine switch OFF.	Press engine switch ON.
	Old fuel or water in fuel.	Drain fuel and replace with fresh fuel.
Flooded with fuel.	Let unit stand for 10 mins.	
Engine starts but runs roughly.	Choke in the wrong position.	Move choke until it stops under RUN position or push in completely.
	Dirty air filter.	Clean or replace air filter.
	Dirty fuel valve.	Clean the fuel valve.
	Clogged spark arrestor.	Clean spark arrestor.
Engine shuts down during operation.	Out of fuel.	Fill fuel tank.
	Low oil level.	Fill crankcase to the proper level. Place generator on a flat, level surface.
	Clogged spark arrestor.	Clean spark arrestor.
Generator cannot supply enough power or overheating.	Generator is overloaded.	Review load and adjust. See "Connecting Electrical Loads."
	Dirty air filter.	Clean or replace air filter.
	Choke in wrong position.	Move choke until it stops under RUN position or push in completely.
Engine is running but no AC output.	Poor cord connection.	Check all connections.
	Circuit breaker is open.	Reset circuit breaker.
	Loose wiring.	Inspect and tighten wiring connections.
	AC Overload: Button illuminated red.	Reduce AC load and press Overload Reset Button until illuminated green.
	Other.	Contact the help line.
Engine hunts or falters.	Engine governor defective.	Contact the help line.
	Dirty fuel valve.	Clean the fuel valve.
	Carburetor is dirty and running lean.	Contact the help line.
	Choke in wrong position.	Move choke until it stops under RUN position or push in completely.
Repeated circuit breaker tripping.	Overload.	Review load and adjust. See "Connecting Electrical Loads."
	Faulty power cords or device.	Check for damaged, bare or frayed wires. Replace defective device.
	Circuit breaker still too hot.	Let unit sit for 5 mins.