

PRECISION TOOLS FROM



"Your Automotive Measuring People"

Micrometers

Rod & Tubular Types

Inside

Outside

Depth

Sets

Dial Indicators & Test Sets

Magnetic Bases

Machinists Tools

Dial Calipers

Electronic Digital Calipers

Torque Wrenches

Cylinder Bore Gages

Write for Catalog



"Your Automotive Measuring People"



"Your Automotive Measuring People"

6615 / 6616 / 6646

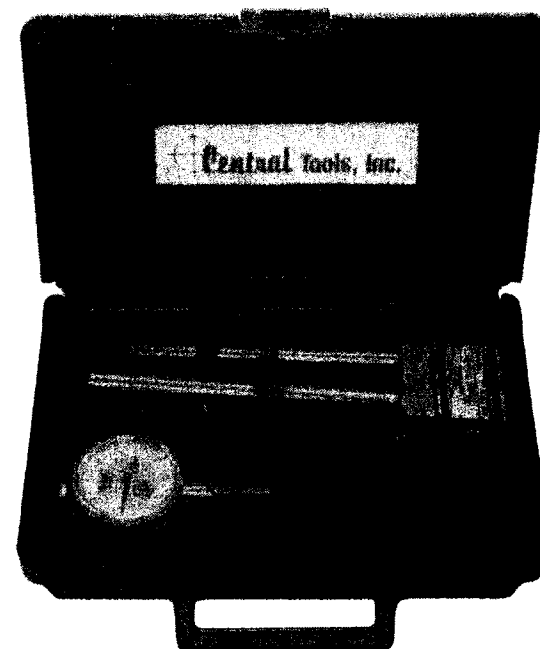

6615 1" RANGE DIAL INDICATOR SET

6616 30 mm RANGE DIAL INDICATOR SET

6646 HIGH PRECISION DIAL INDICATOR

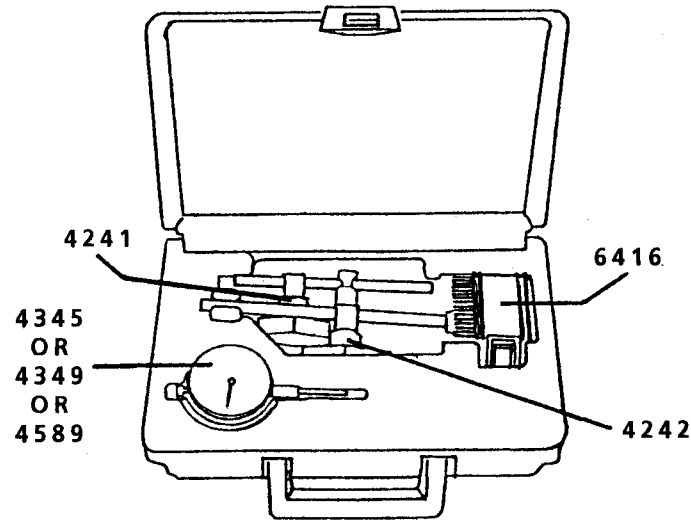

Number	
4345	1" Range Indicator
or 4393	30mm Range Indicator
or 4589	1" High Precision Indicator
4304	Contact point (part of indicator)
4242	Rod Clamp
4241	Indicator Clamp
6416	Magnetic Base Assembly (including Rods and Clamps)

Some uses for these dial indicator sets:

- Checking — camshaft wear
- valve gear backlash
- timing gear backlash
- pinion gear backlash
- driveshaft runout
- disc brake runout
- transmission shaft end play

To take reading —

The 4345 dial is graduated in increments of .001". One full revolution of the large pointer is 2.0mm, ten full revolutions are 1.000".

The no. 4393 is graduated in increments of .01mm. One full revolution of the large pointer is 2.0mm, ten full revolutions are 20mm and fifteen revolutions are 30mm.

A revolution counter (small pointer) is provided to assist in taking long travel readings. It is to be used in conjunction with the larger pointer.



"Your Automotive Measuring People"