

PRECISION TOOLS FROM



"Your Automotive Measuring People"

Micrometers

Rod & Tubular Types

Inside

Outside

Depth

Sets

Dial Indicators & Test Sets

Magnetic Bases

Machinists Tools

Dial Calipers

Electronic Digital Calipers

Torque Wrenches

Cylinder Bore Gages

Write for Catalog



"Your Automotive Measuring People"



"Your Automotive Measuring People"

6419 or 6409



6419 1" RANGE DIAL INDICATOR SET

OR

6409 30mm RANGE DIAL INDICATOR SET

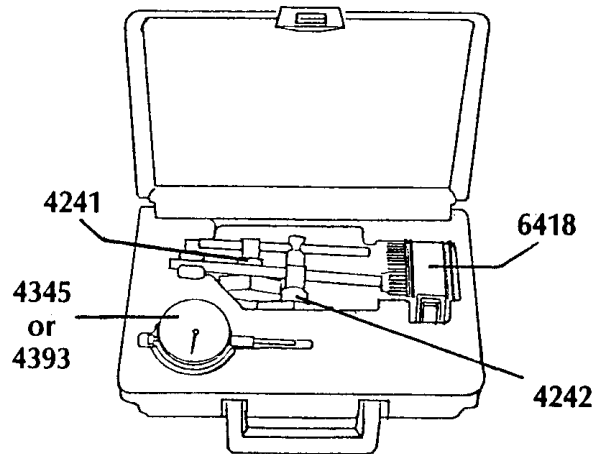

Number	
4345	1" Range Indicator
or 4393	30mm Range Indicator
4304	Contact point (part of indicator)
4242	Rod Clamp
4241	Indicator Clamp
6418	Magnetic Base Assembly (including Rods and Clamps)

Some uses for the 6419

Checking—camshaft wear

- valve guide wear
- timing gear backlash
- pinion gear backlash
- driveshaft runout
- disc brake runout
- transmission shaft end play

Setting up the 6419

1. Attach the Base and push the finger segments down to properly conform to the shape you're adhering to. Always have at least 50% of the fingers in contact with the part you're adhering your Base to.
2. Cycle the cam enough to compress the gaps between the segments, maneuver the Base to desired angle and then cycle the cam completely around to lock the fingers completely.
3. Remove round nut from 4241 clamp and insert stud in indicator back and replace nut.
4. Position indicator plunger against work piece so that it is slightly depressed. Tighten both knobs.

To take reading —

The 4345 dial is graduated in increments of .001". One full revolution of the large pointer is .100" and ten full revolutions are 1.000".

The No. 4393 is graduated in increments of .01mm. One full revolution of the large pointer is 2.0mm, ten full revolutions are 20mm and fifteen revolutions are 30mm.

A revolution counter (small pointer) is provided to assist in taking long travel readings. It is to be used in conjunction with the larger pointer.