

For Best Possible Use of a Dial Indicator

1. Keep all setups as short as possible. Unnecessary length from indicator to the clamp increases the undesirable possibility of indicator movement.
2. Give your indicator the same care required of a good watch. Do not expose it to oil, dirt, water or shock.
3. Most failures of the 6400, 6401 or 6402 are caused by overtightening the contact points. This will result in serious damage which is NOT covered by warranty.
4. For repair of any component, please return the entire set. All repairs are done at the factory, promptly and at a nominal charge.

Over 300 Precision Measuring & Specialty Tools from

- **Micrometers**
 - Rod & Tubular Types
 - Inside
 - Outside
 - Depth
 - Sets
- **Dial Indicators & Test Sets**
- **Magnetic Bases**
- **Machinists Tools**
- **Dial Callipers**
- **Electronic Digital Callipers**
- **Torque Wrenches**
- **Cylinder Bore Gages**

Write for Catalog

 **Central Tools, Inc.**

 **Central Tools, Inc.**

No. 6400, No. 6401 or No. 6402

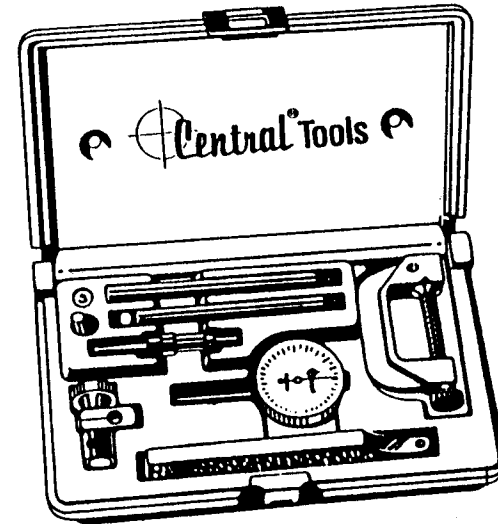

**UNIVERSAL DIAL TEST
INDICATOR SET**

Components of the 6400, 6401, 6402

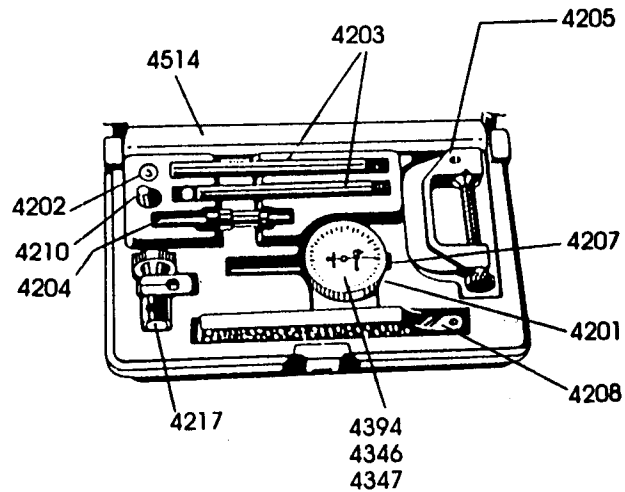

No. 4394	0-2MM Dial Indicator
No. 4346	0-100 Dial Indicator
No. 4347	0-50-0 Dial Indicator
No. 4201	Contact Point, 3/16" Diameter
No. 4202	Contact Point, 5/16" Diameter
No. 4203	8" Sectional Rod, 5/16" Diameter
No. 4204	Hole Attachment, Range .125"
No. 4205	C-Clamp
No. 4217	Universal Rod Connector
No. 4207	Cap for Hole Attachment
No. 4208	Tool Post Holder
No. 4210	Contact Point, 1" long
No. 4514	Plastic Case

Setting Up

1. Secure the 4208 or 4205 to a convenient location.
2. Screw 4203 rods into 4208 or 4205.
3. Place 4203 in large hole of 4217.
4. Place indicator shank in small hole of 4217.
5. Select contact point. When tightening contact in plunger, use only light finger pressure.
6. Position contact point against work-piece and depress plunger .050" to .100". Tighten 4217 firmly.
7. Rotate indicator bezel to set dial at zero reading.

Using the 4204 Hole Attachment - for checking Run Out of Small Bores

1. Unscrew 4207 hole cap.
2. Depress plunger approximately .100".
3. Insert threaded end of hole attachment 4204 into indicator.
4. Be sure that short end of attachment is seated in the plunger pocket before tightening. Do not force the attachment into place. Slight movements of the plunger will allow the attachment to slip into place.
5. When the hole attachment bottoms out against the indicator, it is ready for use.