

OTHER PRECISION TOOLS FROM 
"Your Automotive Measuring People"

Micrometers

Rod & Tubular Types

Inside

Outside

Depth

Sets

Dial Indicators & Test Sets

Magnetic Bases

Machinists Tools

Dial Calipers

Electronic Digital Calipers

Torque Wrenches

Cylinder Bore Gages

Write for Catalog

 **Central Tools, Inc.**

 **Central[®]**

DEPTH MICROMETER

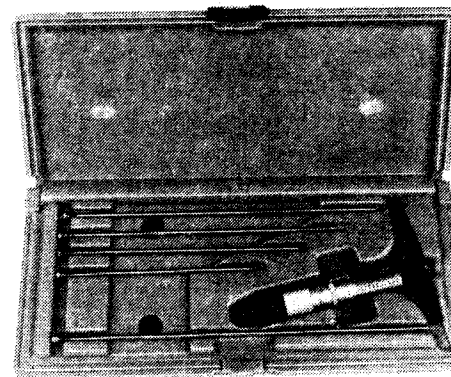

No. 6241

2 1/2" Base

No. 6240	0-3" Range
No. 6241	0-6" Range
No. 6245	0-75mm Range
No. 6246	0-150mm Range

4" Base

No. 6250	0-3" Range
No. 6251	0-6" Range
No. 6255	0-75mm Range
No. 6256	0-150mm Range

5" Base

No. 6253	0-8" Range
----------	------------

 **Central Tools, Inc.**

Cranston, Rhode Island 02910

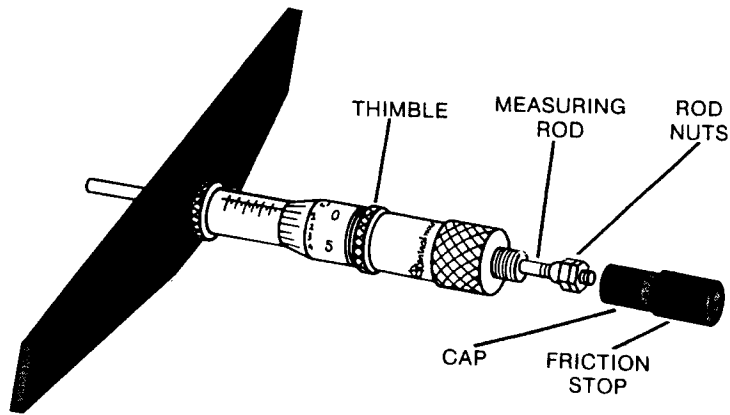

Replacement Rod Part Numbers

English			
4258	0-1"	4262	4-5"
4259	1-2"	4263	5-6"
4260	2-3"	4866	6-7"
4261	3-4"	4867	7-8"
Metric			
4471	0-25mm	4472	25-50mm
4473	50-75mm	4474	75-100mm
4475	100-125mm	4476	125-150mm

USING A DEPTH MICROMETER

The depth micrometer works on the same principle as the outside micrometer. To measure a depth, choose the appropriate length rod and load it into the micrometer. This is accomplished by unscrewing the friction cap, removing the existing rod and loading in the desired rod.

To read the depth measured, rotate the thimble while holding the base down firmly until the rod gently bottoms out in the hole. The measurement read off the micrometer is then added to the particular rod size in the micrometer. Keep in mind that one full revolution of the thimble is .025" on an English micrometer and .50mm on a metric. The barrel is broken down into .025" graduations (.5mm on a metric).

If a rod is out of calibration due to wear, please return the entire micrometer set to factory for re-calibration.