



Maintenance and Safety Manual



An in-depth manual on saw chain theory, safety, maintenance instructions and troubleshooting for Carlton® saw chain, guide bars and drive sprockets

Chain Saw Safety

If you do not have experience and specialized training for dealing with chain saw kickback, then Carlton® urges you to use only low-kickback saw chains which have this green label:

 **ATTENTION – READ THIS:** The saw chain in this package is low kickback saw chain. It met the reduced kickback requirements of ANSI B175.1 and CSA Z62.3 when tested on a representative sample of chain saws. Its safety features significantly reduce the hazard of kickback while maintaining high cutting performance. **ALL CUTTING SAW CHAINS CAN KICK BACK**, which may result in severe personal injury to the chain saw operator or bystanders. Operate your chain saw safety. Read all warnings in your chain saw operator's manual.

Chain pitch	Part numbers			
	.043"/1.1 mm gauge	.050"/1.3 mm gauge	.058"/1.5 mm gauge	.063"/1.6 mm gauge
3/8" LP	N4C-BL	N1C-BL	—	—
.325"	—	K1NK-BL, K1C-BL	K2C-BL	K3C-BL
3/8"	—	A1EP-GL	A2EP-GL	A3EP-GL

Saw chains marked with a yellow label like the one below, are not low-kickback and are intended for use only by professional chain saw operators.

 **ATTENTION – READ THIS:** Warning: this saw chain may be capable of kickback that could result in serious injury to the chain saw operator or bystanders. **DO NOT USE THIS SAW CHAIN UNLESS YOU HAVE EXPERIENCE AND SPECIALIZED TRAINING FOR DEALING WITH KICKBACK.** Saw chains with reduced kickback potential are available.

Chain pitch	Part numbers			
	.043"/1.1 mm gauge	.050"/1.3 mm gauge	.058"/1.5 mm gauge	.063"/1.6 mm gauge
1/4"	—	E1MC-BL		
3/8" LP	N4C	N1C	—	—
.325"	—	K1C, K1L	K2C, K2L	K3C, K3L
3/8"	—	A1EP, A1LM	A2EP, A2LM	A3EP, A3LM
.404"	—	—	B2EP*, B2LM*	B3EP, B3S, B3LM, B3RM10, B3H, B3H-RP

*Chain types to be discontinued in 2014. Contact your authorized Carlton® distributor for availability.

Chain Saw Safety

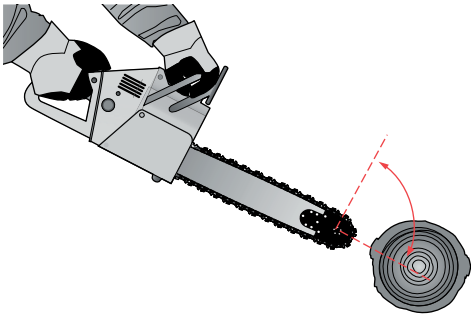

What is kickback?

Kickback is the violent, rapid upward and/or backward motion of the chain saw that can occur when the moving saw chain, near the upper portion of the tip of the guide bar, contacts an object

such as a log or branch, or when the wood closes in and pinches the saw chain in the cut along the top of the guide bar.

Avoiding kickback injury

Be alert at all times to guard against a possible kickback reaction. Always be aware of the position of your guide bar's nose.

Different models of saw chain are available for most cutting tasks. Use the saw chain suitable for your type of cutting with the lowest kickback potential.

The ANSI standard* contains test methods to evaluate the kickback potential for both chain saws and replacement saw chain. The saw chain classification chart on the facing page is designed to help you select appropriate replacement saw chains in order to maintain compliance with the ANSI standard.

CLASSIFIED
UL US
17R2

LOW KICKBACK SAW CHAIN
IN ACCORDANCE WITH ANSI
B175.1-2000, PARAGRAPH
5.11.2.4 AND WITH
CSA Z62.3

The saw chain in this package is low kickback saw chain. It met the reduced kickback requirements of ANSI B175.1 when tested on a representative sample of chain saws. Type C low-kickback saw chain meets the kickback performance requirements of CSA Standard Z62.3.

Carlton® packaging and labeling: Saw chains that comply with ANSI B175.1-2000 are identified as low-kickback saw chain and carry the UL Classification marking.

Chainsaws and the ANSI standard
The ANSI standard divides all gasoline powered chain saws into two groups:

Chain saws smaller than 3.8 cubic inches (62 cc) must meet low-kickback performance requirements in the standard (paragraph 5.11.2.1). The manufacturer is required to mark these chain saws identifying at least one replacement bar and chain combination that will provide performance confirming to low-kickback requirements.

Chain saws at 3.8 cubic inches (62 cc) and above may, but are not required to, comply with ANSI low-kickback provisions. Chain saws that do not meet the low-kickback performance requirements are required to be marked with a warning such as:

⚠ WARNING: This chain saw may be capable of severe kickback that could result in serious injury to the operator and bystanders. Do not use this chain saw unless you have experience and specialized training for dealing with kickback. Saw chain with reduced-kickback potential may be available.

*The ANSI standard applies to North America only.

Chain Saw Safety

Replacement saw chain and the ANSI standard

When replacing the chain on chainsaws below 3.8 cubic inch displacement (62 cc), any low-kickback chain of the proper pitch, gauge, and drive link count can be used. Carlton provides replacement saw chain that is labeled in accordance with the ANSI standard. The **green-highlighted** chain types are low kickback. The **yellow-highlighted** chain types are **not** low-kickback and should only be used by those with experience and specialized training for dealing with kickback.

Replacement guide bars and the ANSI standard

The ANSI standard states: Because of differences in replacement guide bars, the following guidelines shall be considered when determining kickback energy:

- A. Sprocket nose guide bars with the same effective length, the same number of sprocket nose teeth, the same nose radius, and the same pitch may be considered to have the equivalent kickback energy.
- B. A hard-nose guide bar having the same effective bar length, and the same or smaller nose radius as a sprocket-nose bar, may be considered to have equivalent or less kickback energy than the sprocket nose bar.
- C. Kickback energy of all guide bars may be considered to be less for smaller nose radius sizes.

When replacing guide bars, to maintain approximately the same kickback energy of a chain saw, the nose size (radius) of the replacement bar should be equal to or smaller than the original-equipment nose – with the same bar length.

Chain Saw Safety

Recommended personal protective equipment



Wear a hard hat to protect your head.

Wear ear protection to protect your ears.

Wear safety goggles, glasses or a face shield to protect your eyes.

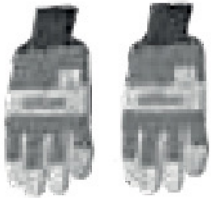

Wear gloves to prevent slippage and to protect your hands.



Wear protective pants or chaps to protect your legs.



Wear chain saw protective boots or safety boots and gaiters to protect your feet.

Dress properly—do not wear clothing that is too tight or too loose.

*These Carlton® safety clothing items are available in Europe only.

Chain Saw Safety

Proper work practices

- Use a right-hand grip only to hold your chain saw; right hand on the trigger, left hand on the front handle. **NEVER** operate with one hand!
- Keep your left arm straight for better control.
- Hold the chain saw firmly with both hands. Keep your thumb firmly wrapped around the front handle.
- Stand to the side of the chain saw, never behind it.
- Run the engine at full throttle.
- Use a low-kickback saw chain and a reduced-kickback guide bar whenever possible.
- **Keep the chain saw, saw chain, guide bar and drive sprocket properly maintained.**
- Stand with your feet well braced and your body balanced.
- Cut only wood with your chain saw. Do not cut any other materials.
- Plan for a clear retreat from a falling tree or branches.

CAUTION

- Keep yourself clear of the work. **Before cutting** check for hazards like tree limbs, power lines, dead trees, etc. Calculate how the object being cut will fall. Determine if the chain saw may be thrown unexpectedly by the movement of the cut material. If possible, position yourself to avoid injury, away from the natural lean of the tree.
- Never cut above shoulder level.
- Never cut while in a tree or while on a ladder.
- Keep others a minimum of two tree lengths away from the cutting area.
- Do not allow others to hold wood during cutting.
- Do not operate a chain saw when fatigued or otherwise impaired.
- When transporting your chain saw, use the appropriate guide bar cover.

Saw Chain

Introduction	2
Carlton® Saw Chain Components.....	3
How Saw Chain Cuts Wood	6
Carlton® Saw Chain Line.....	7
Carlton® Filing Specifications	10
Carlton® Maintenance Tools.....	11
Saw Chain Maintenance	12
Saw Chain Troubleshooting.....	20

Guide Bars

Carlton® Guide Bar Types	26
Guide Bar Components and Maintenance.....	29
Guide Bar Troubleshooting.....	31

Drive Sprockets

Drive Sprocket Terms.....	32
Drive Sprocket Maintenance	33
Cutting in Cold Weather.....	36

Introduction

This manual is designed to help you obtain the full performance and cutting efficiency that was built into your Carlton® saw chain.

The Carlton brand is dedicated to education. In our experience, the most misunderstood part of a chain saw is the cutting chain. We stress the importance of maintenance as a means to promote repeat sales; when we teach you, our valued customer, how to get the most out of our quality products, we know you'll buy more!

Some people believe that you need expensive grinding equipment and specialized training to properly maintain your Carlton saw chain and guide bar. In fact, a few basic tools are all you need to maintain your saw chain and guide bar.

By reading through this handbook you will learn:

- How the saw chain actually cuts wood.
- The differences between the various cutter tooth styles.
- The proper way to maintain Carlton saw chain cutter teeth and depth gauges.
- How to maintain Carlton guide bars.
- How to identify the wear patterns caused by improper maintenance that can lead to the failure of your saw chain, guide bar and/or drive sprocket.

If you prefer not to perform your own maintenance, all our Authorized Carlton Dealers are trained to service all Carlton products. A properly maintained saw chain and guide bar makes any chain saw cut more safely and efficiently.

An inventory of the component parts of saw chain is essential to understanding how it functions. Please use page 3 to reference the terms used in this book.

Saw Chain Components

EXPLODED VIEW OF SAW CHAIN

Guard link saw chain

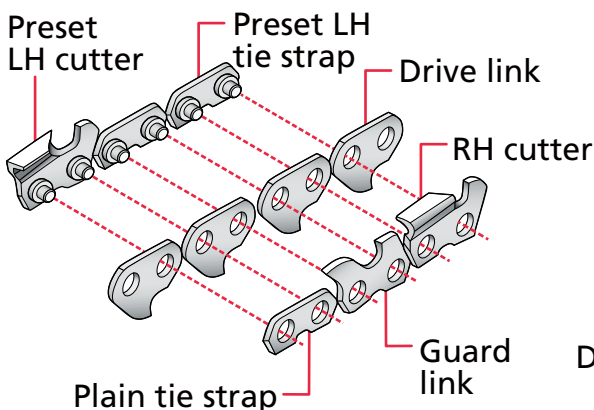

Bumper link saw chain

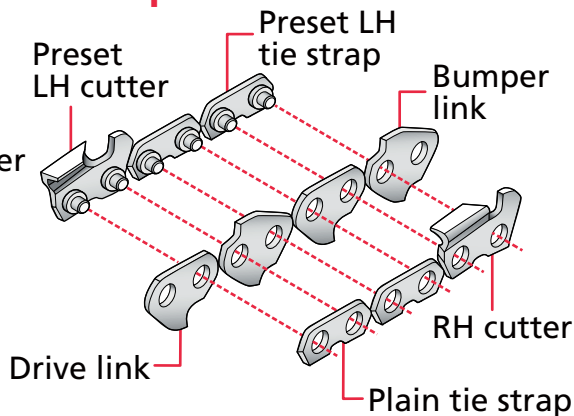

Cutter tooth

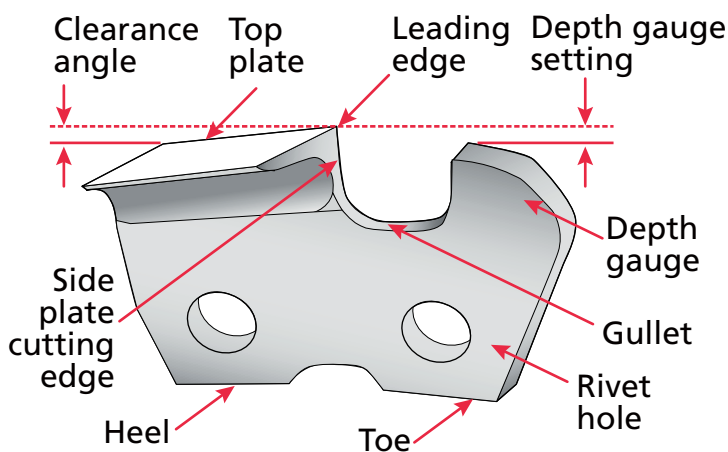

Drive link

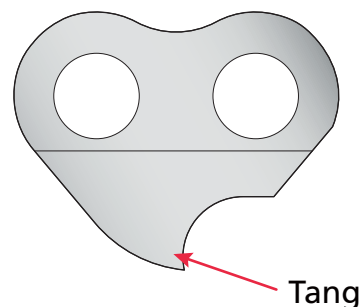

Tie strap

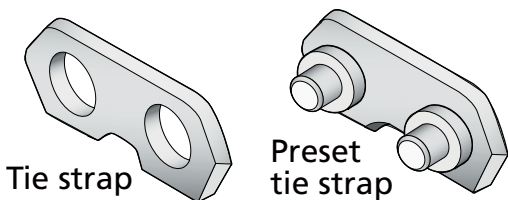

Rivet

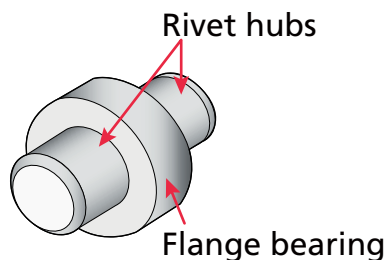

Carlton® Technical Tip

Saw chain parts may look alike but they are **not** interchangeable. Never install used parts or mix different manufacturer's parts when repairing or making up saw chain loops. Always use **only** the manufacturer's replacement parts.

Saw Chain Components

Saw chain pitch

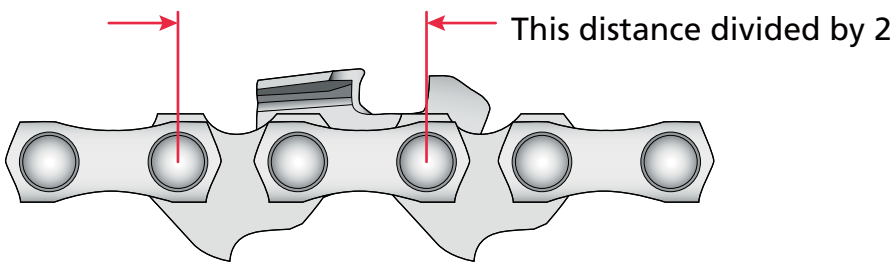

The word **pitch** actually means size. The larger the pitch (measured in thousandths of an inch) the larger the saw chain. Pitch is determined by measuring the distance between the centerlines of three consecutive rivets and dividing this distance in half. In other words, 3/8" pitch saw chain (.375") measures 3/4" (.750") between the centerlines.

Saw chain gauge

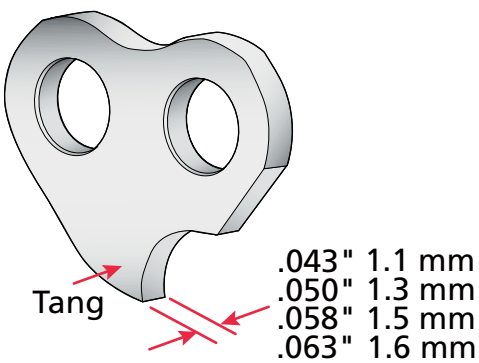

Gauge refers to the thickness of the drive link tangs that fit into the guide bar groove and is also measured in thousandths of an inch. There are four standard gauges for hand held chain saw cutting chain: .043", .050", .058" and .063". It's essential for the saw chain's gauge to match the guide bar gauge.

Carlton® Technical Tip

1. Saw chain pitch must match the pitch of the drive sprocket and the guide bar sprocket tip.
2. Saw chain gauge must match the gauge of the guide bar. Any mismatch of the chain saw parts will lead to premature failure of the saw chain, guide bar, or drive sprocket.

Kerf

Kerf is the overall width of the cut that the saw chain makes in the wood. Kerf is measured from the outsides of the left hand and right hand cutters.

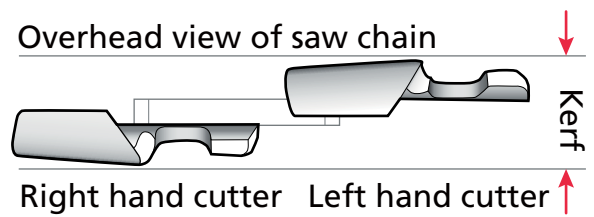

Cutter styles

Tooth size, shape and leading edge determine the efficiency and durability of saw chain and provide a history lesson in saw chain design. Most of the saw's power is consumed by cutting the cross grains of the wood.

The first *modern* cutter design is called **Chipper chain**. It has a thick top plate and side plate as well as a large radius to the leading edge. This saw chain is very durable but requires a lot of power.

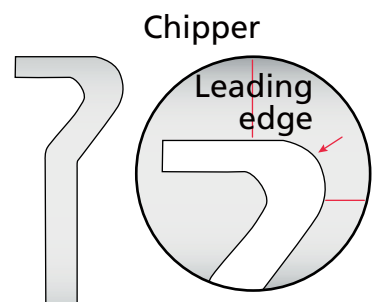

Semi-Chisel chain is essentially a streamlined chipper design. It features a tapered top plate, a relieved side plate and a smaller radius to the leading edge. This greatly increases cutting efficiency without sacrificing much durability.

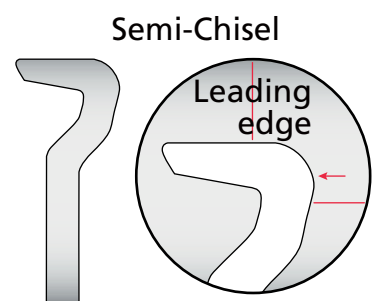

Chisel chain is designed for all-out cutting performance by making the leading edge a pointed square corner. Chisel chain's squared cutter also cuts faster by severing all of the wood fibers in the kerf in one pass. The actual leading edge of the point does most of the cutting and is easily damaged in abrasive conditions. As a result, chisel chain is best suited for clean, standing timber.

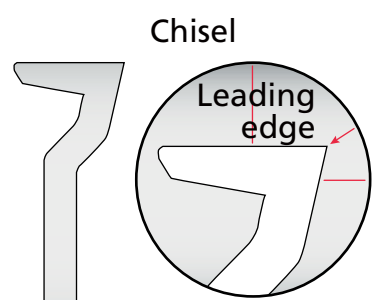

Carlton® Technical Tip

For optimal cutting, match the saw chain to the cutting conditions. Chipper chain is the most durable for abrasive conditions. Chisel chain is popular, but the leading edge point is more easily damaged, making it a poor choice for abrasive conditions. Semi-Chisel chain is the best compromise of speed and durability.

How Saw Chain Cuts Wood

To help you properly maintain your Carlton® saw chain, avoid the problems of poor maintenance and recognize the wear patterns that can cause saw chain and guide bar failure, it is essential to first learn how saw chain cuts wood. You might be surprised to learn that a cutter tooth must actually leave the guide bar to cut wood efficiently.

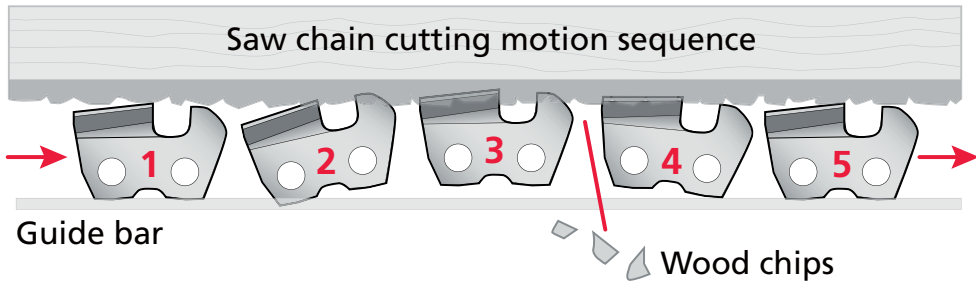

All saw chain cuts with a rocking motion. When cutting properly, saw chain resembles a dolphin swimming in the ocean. As the cutter enters the wood, the **leading edge** starts to bite (1) causing the cutter to rock back as far as the depth gauge will allow (2). The cutter is now in the **attack position**. The cutter jumps off the guide bar and into the wood (3). Saw chain tension and power from the saw pull the cutter back out of the wood and the severed chip exits from the underside of the cutter (4). The cutter then returns to its original position (5). Any condition that upsets this smooth and efficient rocking motion will have a negative effect on the durability, performance and cutting efficiency of any saw chain.

Depth gauges

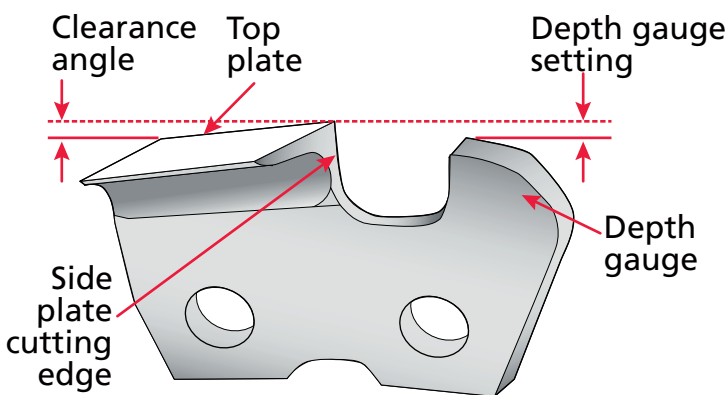

Depth gauges are occasionally called rakers because some believe they “rake” out the severed chips. While it is normal for the depth gauge to sink into

the wood under certain conditions as illustrated in positions (2) and (3), the actual function of the depth gauge is determining how large a bite the cutter will take from the wood.

The clearance angle of the cutter is the reason saw chain is able to cut with an efficient rocking motion. The rear of the top plate is lower in height than the front. This allows the cutter to tip forward (4) and exit the wood cleanly. *Maintaining the clearance angle and the depth gauges are covered in detail on pages 12 – 14.*

Carlton® Saw Chain Line

Carlton® saw chain key



Chisel



Semi-Chisel



Micro chisel



Chipper

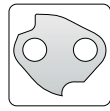

Bumper link

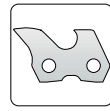

Guard link

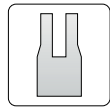

Narrow kerf



Ripping chain



Consumer chain



Semi-pro chain



Pro use chain

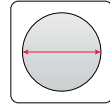

File diameter

● Yes
▲ No

ANSI

P/N					ANSI
E1MC-BL	1/4"	.050" (1.3 mm)		5/32" (4.0 mm)	▲











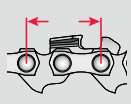

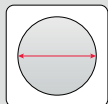







N4C	3/8" LP	.043" (1.1 mm)		5/32" (4.0 mm)	▲
N4C-BL	3/8" LP	.043" (1.1 mm)		5/32" (4.0 mm)	●
N1C	3/8" LP	.050" (1.3 mm)		5/32" (4.0 mm)	▲
N1C-BL	3/8" LP	.050" (1.3 mm)		5/32" (4.0 mm)	●

Carlton® Saw Chain Line

P/N					ANSI
K1L K1LSK* K2L K3L K3LSK*	.325"	.050" (1.3 mm) .050" (1.3 mm) .058" (1.5 mm) .063" (1.6 mm) .063" (1.6 mm)		11/64" (4.5 mm)	▲
K1NK-BL	.325"	.050" (1.3 mm)		3/16" (4.8 mm)	●
K1C K2C K3C	.325"	.050" (1.3 mm) .058" (1.5 mm) .063" (1.6 mm)		3/16" (4.8 mm)	▲
K1C-BL K2C-BL K3C-BL	.325"	.050" (1.3 mm) .058" (1.5 mm) .063" (1.6 mm)		3/16" (4.8 mm)	●
A1LM A1LMSK* A2LM A3LM A3LMSK*	3/8"	.050" (1.3 mm) .050" (1.3 mm) .058" (1.5 mm) .063" (1.6 mm) .063" (1.6 mm)		7/32" (5.5 mm)	▲
A1EP A1EPSK* A2EP A3EP	3/8"	.050" (1.3 mm) .058" (1.5 mm) .063" (1.6 mm)		7/32" (5.5 mm)	▲
A1EP-GL A2EP-GL A3EP-GL	3/8"	.050" (1.3 mm) .058" (1.5 mm) .063" (1.6 mm)		7/32" (5.5 mm)	▲

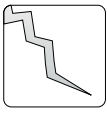
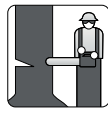



Carlton® Saw Chain Line

P/N					ANSI
B2EP	.404"	.058" (1.5 mm)		7/32" (5.5 mm)	▲
					
B3EP	.404"	.063" (1.6 mm)		7/32" (5.5 mm)	▲
					
B3S	.404"	.063" (1.6 mm)		7/32" (5.5 mm)	▲
					
B3LM	.404"	.063" (1.6 mm)		7/32" (5.5 mm)	▲
					
B3H-RP	.404"	.063" (1.6 mm)		7/32" (5.5 mm)	▲
			 		
B3RM10	.404"	.063" (1.6 mm)		7/32" (5.5 mm)	▲
					

Carlton® Filing Specifications

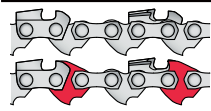
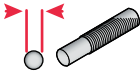
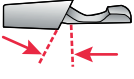
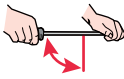
Carlton® Filing Specifications

				
E1MC-BL	5/32" 4.0 mm	30°	90°	.025"
N4C-BL	5/32" 4.0 mm	35°	90°	.025"
N4C	5/32" 4.0 mm	35°	90°	.025"
N1C-BL	5/32" 4.0 mm	35°	90°	.025"
N1C	5/32" 4.0 mm	35°	90°	.025"
K1NK-BL				
K1C-BL K2C-BL K3C-BL	3/16" 4.8 mm	30°	90°	.025"
K1C K2C K3C	3/16" 4.8 mm	30°	90°	.025"
K1L K2L K3L	11/64" 4.5 mm	30°	10°	.025"
A1EP-GL A2EP-GL A3EP-GL	7/32" 5.5 mm	35°	90°	.025"
A1EP A2EP A3EP	7/32" 5.5 mm	35°	90°	.025"
A1LM A2LM A3LM	7/32" 5.5 mm	30°	10°	.025"
B2EP B3EP	7/32" 5.5 mm	35°	90°	.030"
B3S				
B3H-RP	7/32" 5.5 mm	5 – 10°	90°	.040"
B3LM	7/32" 5.5 mm	35°	10°	.040"
B3RM10	7/32" 5.5 mm	10°	10°	.040"

Filing tools

Filing kit

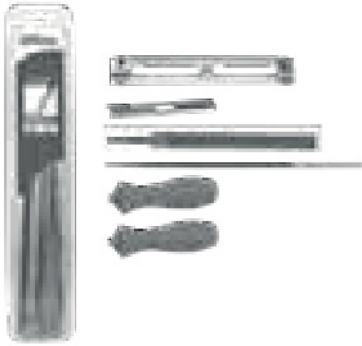

Round file



Flat file



File handle



Stump vise



Bar-mounted sharpener

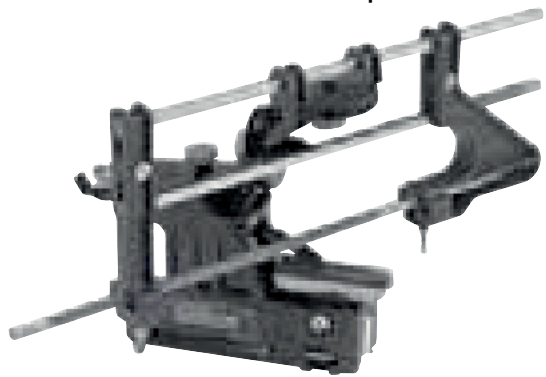

Grinders

Electric bench saw chain grinder



12V electric saw chain sharpener



Grinding wheels



Sharpening stones



Saw chain repair tools

Chain breaker



Rivet spinner



Saw Chain Maintenance

Sharpening basics

Any product requiring routine maintenance should always be serviced according to the manufacturer's recommendations. Cutting angles and depth gauge settings are designed into your Carlton® saw chain at the factory and have proven best for a wide range of cutting conditions. Maintaining your Carlton saw chain to factory specifications will ensure full saw chain durability and cutting efficiency. It will also allow you to cut more wood with less effort.

Cutters lose their sharp edge and become dull from extended cutting, from abrasives in the wood (sand, ashes, grit) or from hitting foreign objects such as dirt, nails, rocks, and pavement. A good sharpening job restores each cutter's leading edge with specific filing angles recommended by the factory. The leading edge is the most important part of the cutter, because it does most of the work.

As a cutter is repeatedly sharpened, the tooth gets shorter than the depth gauge as it's filed away. This brings us to the second aspect of saw chain sharpening.

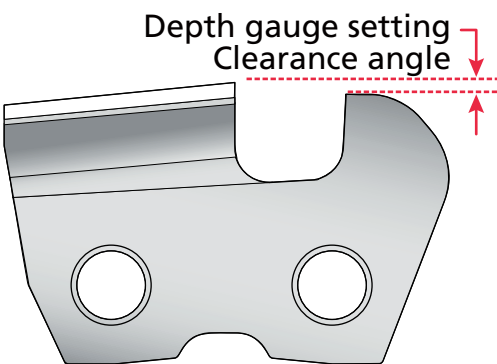

The height of the **depth gauge** in relation to the height of the leading edge of the cutter determines the size of the bite that the tooth can take. Consequently, the depth gauge must be lowered in proportion to the decreased cutter height to

keep the factory designated clearance angle, and keep the saw chain self-feeding into the wood.

Understanding depth gauges

The least understood part of depth gauge maintenance (aside from not knowing that depth gauges need to be maintained at all) is how much to file the depth gauges down each time the cutter is sharpened. If the depth gauges are not lowered enough, the saw chain will not cut efficiently. If depth gauges are lowered too much, the saw chain will cut, but cut very aggressively. *Please see page 10 for filing specifications for the Carlton family of saw chain.*

A **new cutter** (1.) has a depth gauge setting that will feed into the wood efficiently. The **depth gauge setting** is the distance between the height of the depth gauge relative to the overall height of the cutter. This distance determines the size of the bite that a cutter can take. As the cutter is filed back, its overall height becomes lower. The depth gauge must be filed down as the cutter gets shorter (and lower) to keep the saw chain self-feeding.

The next cutter (2.) has been partially filed back **without lowering the depth gauge**. This cutter cannot feed into the wood because it has no depth gauge setting. In fact, the depth gauge in this cutter will actually hold the cutter tooth away from the wood. This condition is known as “high” depth gauges. When the saw chain stops cutting effectively, many operators will push down, adding more feed pressure. The saw chain is forced into the wood, causing cutter bottoms to wear rapidly and makes cutting wood much more difficult.

The third cutter (3.) has the same cutter length and height as the second cutter, but the **depth gauge** has been lowered to compensate for the shorter cutter height. As a result, cutter #3 will cut as effectively as the new cutter.

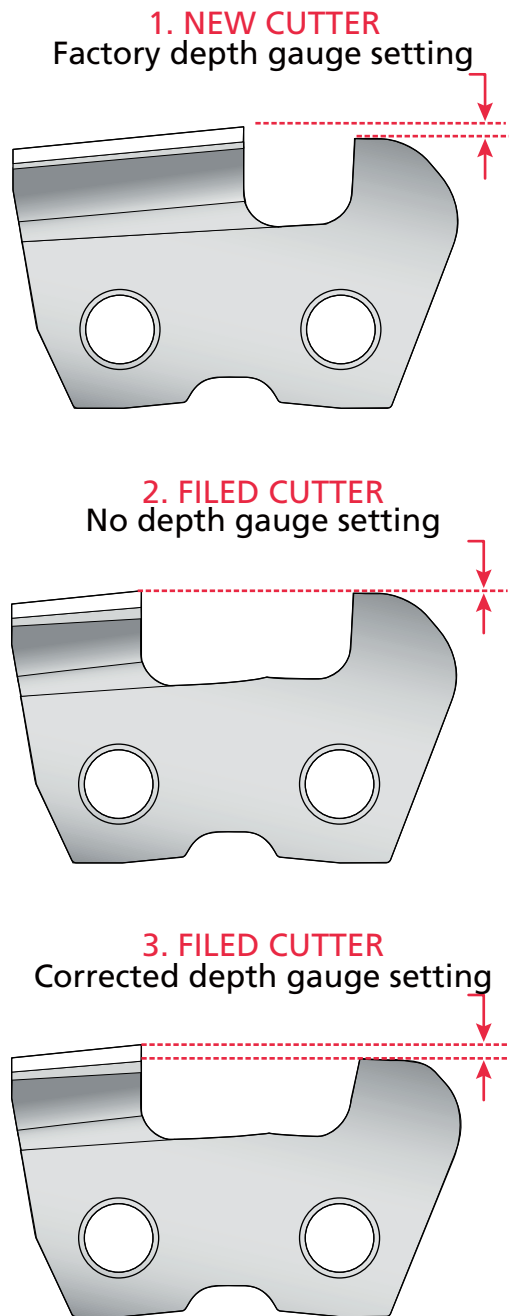

Saw Chain Maintenance

Setting Depth Gauges

1. Use a depth gauge tool with the correct built-in setting for your saw chain and check your depth gauges every three or four sharpenings.
2. Place the tool on top of your saw chain so one depth gauge protrudes through the slot in the tool.
3. If the depth gauge extends above the slot, file the depth gauge down level with the top of the tool using a flat file. Never file the depth gauge down enough to exceed the depth gauge setting specified in this manual for your Carlton saw chain.

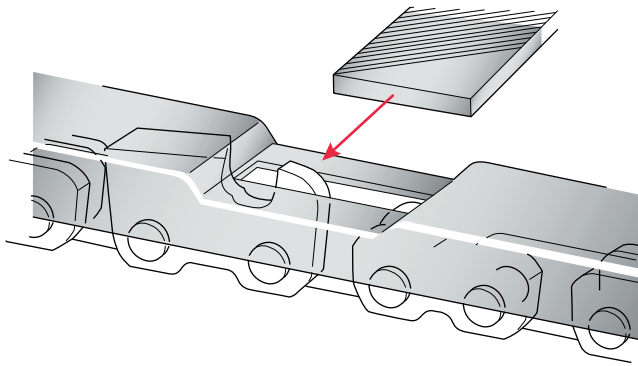

NOTE: Do not file or alter the tops of kickback-reducing bumper or guard drive links.

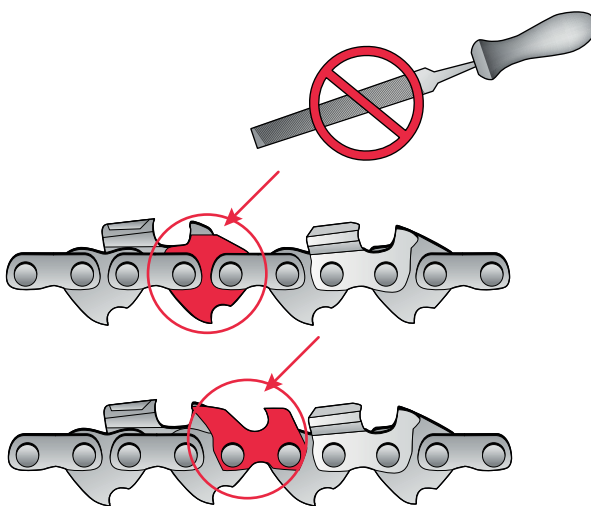

Carlton® Technical Tip

Depth gauges don't wear down by themselves. They're made from the same hardened steel as the rest of the cutter. Depth gauges must be filed down as the cutter is filed shorter in length and lower in height to keep the saw chain self feeding into the wood.

How to sharpen cutters

1. Be sure 1/5th or 20% of the file's diameter is always held above the cutter's top plate. Using the correct file guide is the easiest way to hold the file in this position.

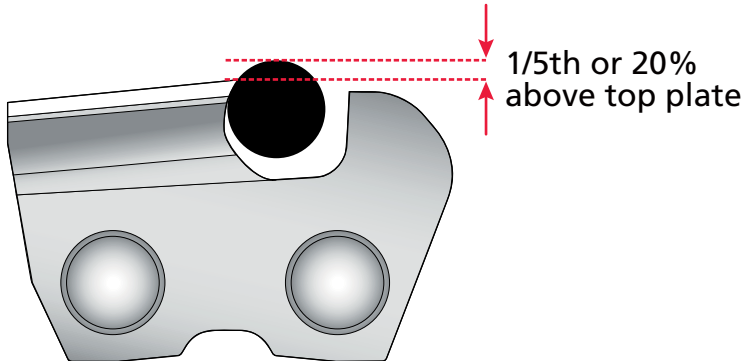

2. Keep the correct **top plate filing angle** line on your file guide parallel with your saw chain.

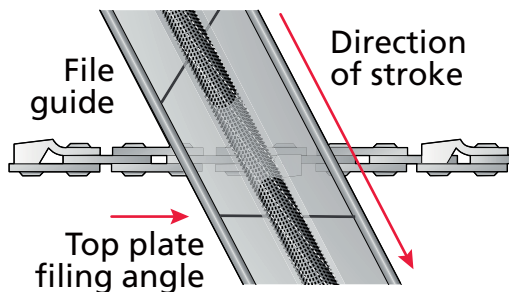

3. Sharpen cutters on one side of the saw chain first. File from the inside of each cutter to the outside. Then turn your chain saw around and repeat the process for cutters on the other side of the saw chain.

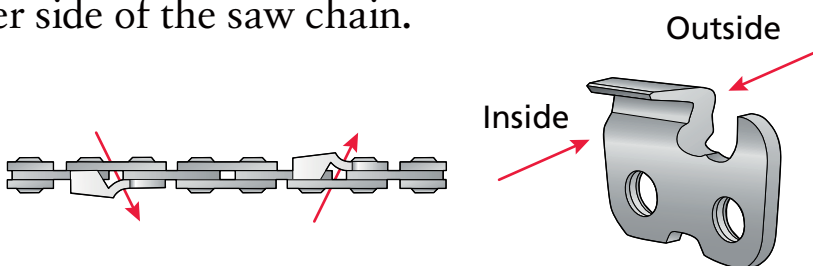

4. Keep all cutter lengths equal.

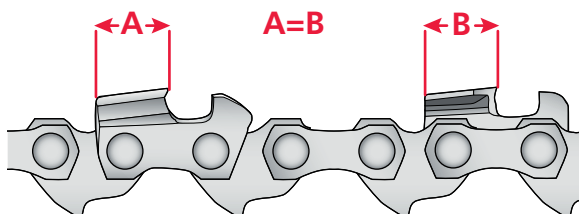

Saw Chain Maintenance

Saw chain tension

1. Turn the engine off. Let the saw chain cool completely.
2. Loosen guide bar mounting nuts on the side of your chain saw.
3. Pull the guide bar nose up, and keep it up as you adjust tension.

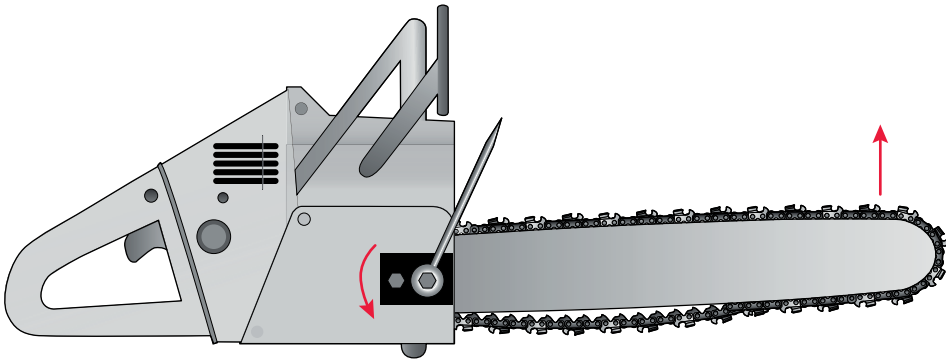

For a solid nose guide bar: Turn your chain saw's tension adjustment screw until the bottoms of the lowest tie straps and cutters come up and just touch the bottom of the guide bar rail. A properly tensioned saw chain should have a small amount of sag at the mid-point of a solid nose guide bar.

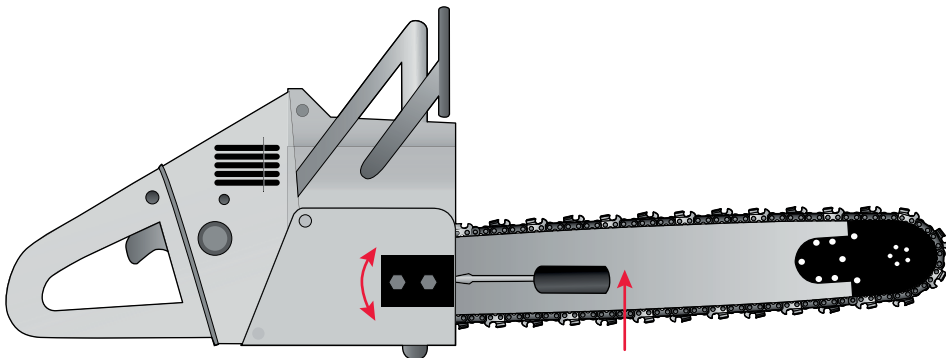

For a sprocket nose guide bar: Tension must be tighter than on a solid nose guide bar. Turn your chain saw's tension adjustment screw until the bottoms of the lowest tie straps and cutter come up and solidly contact the bottom of the guide bar rail.



Carlton® Technical Tip

Never tension your saw chain right after cutting when the saw chain has expanded in length from the heat. Saw chain tensioned while hot will contract when it cools, and can damage your guide bar and saw chain. **ONLY TENSION SAW CHAIN WHEN THE SAW CHAIN HAS COOLED.**

How to install new saw chain parts

NOTE: Use only Carlton parts to repair Carlton saw chain, and only use parts which are the correct size and type for your saw chain.

Remove rivets, and parts to be replaced, as shown under “How to break out rivets,” in the next section. Never reassemble a saw chain with old preset tie straps; always use **NEW** preset tie straps.

If needed, file off the bottom of the new parts to match the existing worn parts. File new cutters back to match the worn cutters. Do not file the tops of kickback-reducing bumper drive links or guard links.

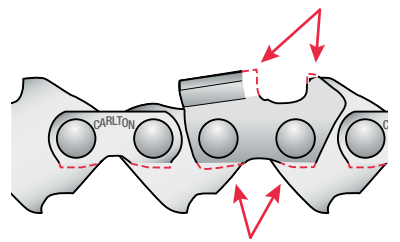

Place the **preset tie strap** on a flat outer surface of a saw chain breaker anvil. Be sure the rivets are pointing up. Assemble the saw chain to the preset tie strap; be sure to assemble the regular tie strap with the landmark face up, and the notch towards the drive link tangs. **Note: New rivet heads may be smaller and shaped differently than factory-spun heads.**

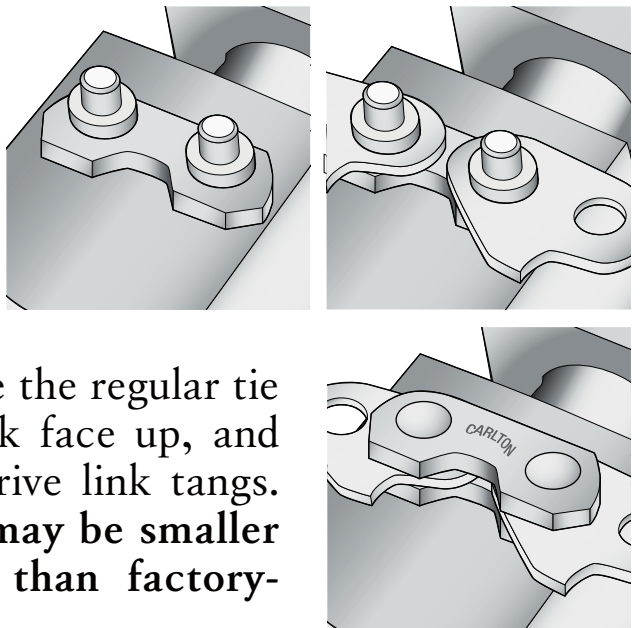

Make sure all the parts are assembled in the correct location and sequence. Please see the illustrations on page 3. If unsure, ask your Carlton dealer.

Carlton® Technical Tip

Rivet heads must be snug and secure while still allowing all joined parts to move freely. Rapid wear leading to possible saw chain breakage and personal injury can be caused by rivet heads that are either too tight or too loose.

Saw Chain Maintenance

How to replace rivets



NOTE: Always wear approved safety accessories for hands and face when replacing rivets.

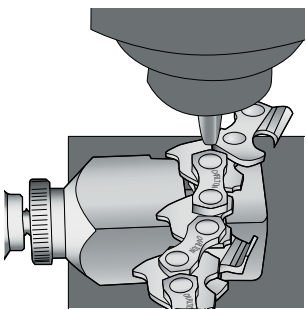
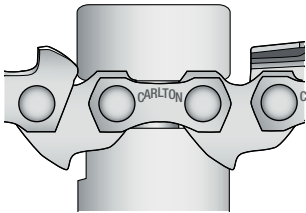

When using slotted anvils the pitch of the saw chain to be broken should match the numbered chain breaker anvil slot. See pages 7 – 9 to identify your saw chain’s pitch. Insert the saw chain portion for breaking into the proper slot of the saw chain anvil and push saw chain forward until bottom tie strap is flush with the far side of the slot. (This supports the drive link on both sides of the slot.)

When using an adjustable anvil insert the saw chain portion for breaking into the adjustable jaw. Push the chain forward until the bottom tie strap is flush with the far side of the jaw. Tighten the jaw until it clinches both sides of the bottom tie strap and the drive link is supported on both sides of the jaw slot.

Position the rivet head directly under the anvil punch. Pull the punch handle down; do not use excessive force.

NOTE: It’s important when breaking saw chain at the cutter to make sure cutter is in the top position.

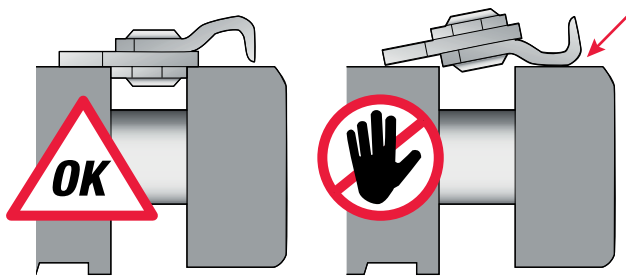

Removing rivets from broken drive links

When removing rivets from broken drive links, hold the two broken segments together in their original (unbroken) positions as you tighten the saw chain link in the adjustable anvil.

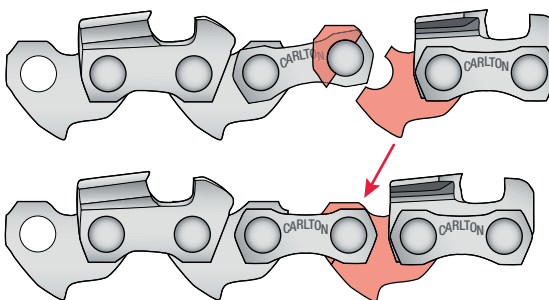

See the “How to replace rivets” section previous to continue with repairs.

How to break in new saw chain

The durability of your new saw chain can be extended by following these few simple steps before using it.

Oil your saw chain prior to use.

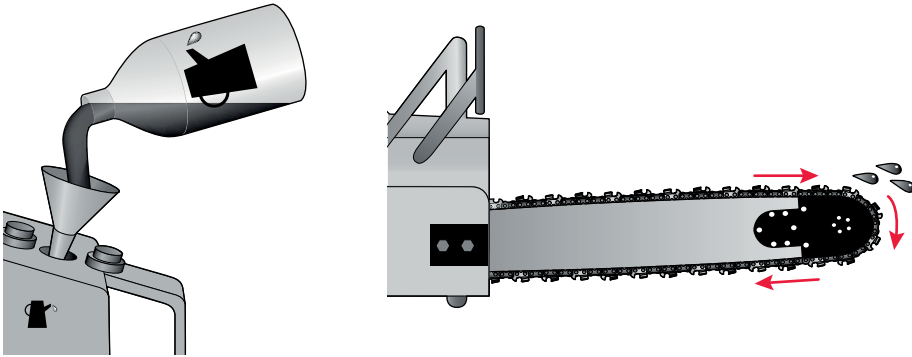

Never run any saw chain on a worn drive sprocket rim or spur system*, especially a new saw chain. **Replace your rim or spur system** after every two saw chains, or sooner.

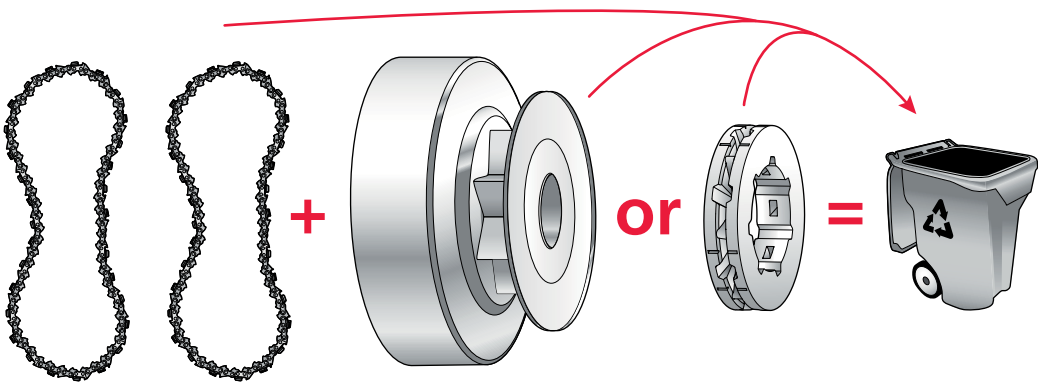

Run your new saw chain at half throttle for several minutes before doing any cutting in order to allow oil to reach all parts of the guide bar and saw chain. Allow the chain saw and the cutting system to warm up fully.

Also recommended: **Dipping the saw chain in guide bar oil** or drizzling oil down the length of the saw chain on the guide bar before running it. This gives the saw chain maximum lubrication at the bearing surfaces and rivets.

Stop and **check saw chain tension**, let saw chain cool, and adjust tension often during operation, as shown on page 16.

Keep the first several cuts light. Keep extra oil on the cutting system during these first cuts, and do not apply heavy pressure.

*See page 32 for drive sprocket wear-depth indicators.

Saw Chain Troubleshooting



Carlton® Technical Tip

Most saw chain problems are caused by four things: incorrect saw chain tension, incorrect filing, lack of lubrication and cutting any material other than wood.

Here are some things you should look for, and the corrective actions you should take:

Problem:

Cuts slow, cuts too aggressively, or won't hold an edge.

Look closely at your saw chain's cutters, and compare them to the illustrations following.

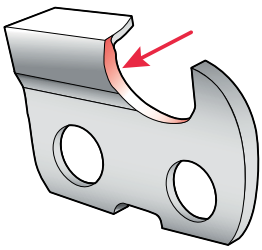

Light abrasive damage on side plates

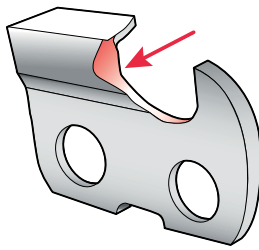

Severe abrasive damage on side plates

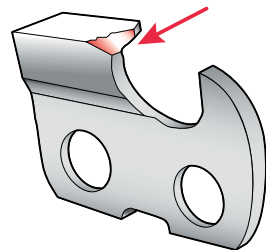

Abrasive or impact damage to top plate or working corner

Remedy: File cutter back until all damage is removed

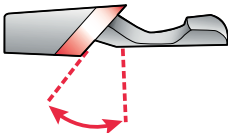

Too much top plate filing angle

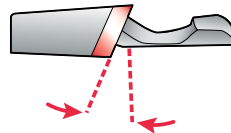

Too little top plate filing angle

Remedy: Resharpener cutters while holding your file at the correct top plate filing angle for your saw chain. Be sure your file guide is stamped with your saw chain's correct top plate angle.

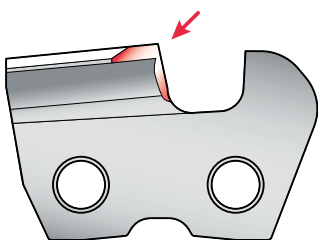

Too much top plate cutting angle

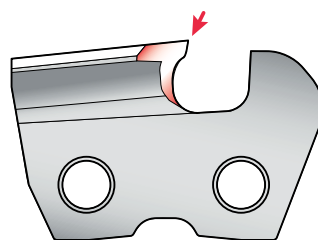

Too much hook in side plate

Remedy: Either your file was too small or it was held too low. Resharpener cutters with a file of the correct size, held in the correct position. Use the correct file guide.

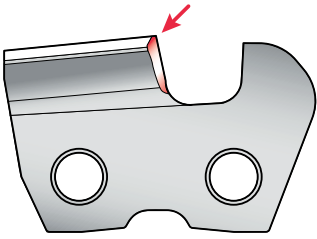

Too little top plate cutting angle

Remedy: Either your file was too large or it was held too high. Resharpen cutters with a file of the correct size, held in the correct position. Use the correct file guide.

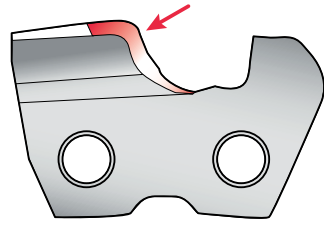

Backslope on side plate

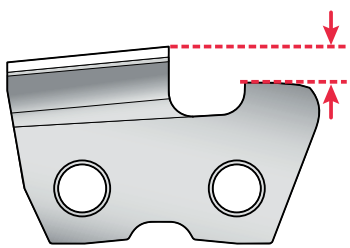

Low depth gauges

Remedy: In most cases, cutters cannot be filed back enough to correct for depth gauges that are too low. Replace the saw chain.

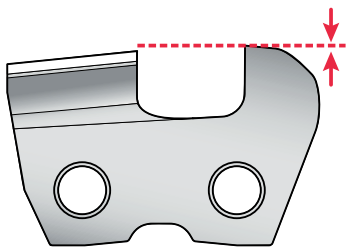

High depth gauges

Remedy: File depth gauges down to their correct height.

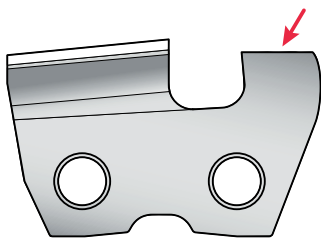

Square or blunt depth gauges

Remedy: File the front corners of depth gauges parallel to their original rounded or ramped shape.



Carlton® Technical Tip

To keep the low-kickback features that have been manufactured into the saw chain, it is imperative to maintain depth gauges according to the saw chain manufacturer's specifications. (See page 10 for correct depth gauge settings.)

See pages 14 – 15 for the proper filing techniques to use when performing the remedies above.

Saw Chain Troubleshooting

Problem:
Cutters and tie straps wear heavily or break.

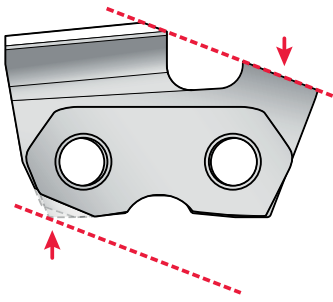

Excessive heel wear on cutters and opposite tie straps.

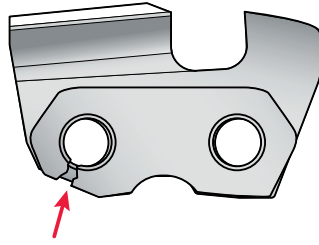

Cracks under rear rivet holes on cutters and opposite tie straps.

Remedy: Replace worn or cracked cutters and/or tie straps. **NOTE:** One or more of the following may be required to prevent future wear and/or cracks: (1) Refile cutters using the correct angles. (2) Keep more lubrication on the saw chain and guide bar. (3) Reduce the amount of depth gauge setting (may require replacement of the saw chain). (4) Do not force dull saw chain to cut. (5) Do not force saw chain through frozen wood. (6) Keep cutters sharp. (7) Always maintain proper tension.

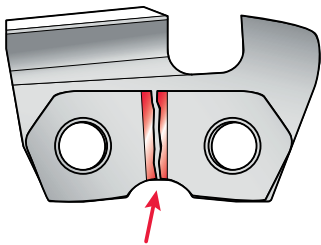

Tie straps between cutters broken in the center.

Remedy: Such breakage is usually caused by incorrect field assembly of preset tie straps. Breakage usually occurs on the tie strap opposite the factory preset tie strap. See page 17 for correctly shaped rivets.

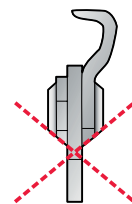
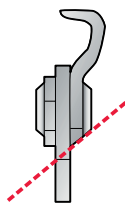
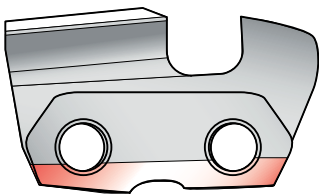

Bottoms of tie straps and cutters worn out of square.

Remedy: Dress the tops of the guide bar's rails square. If wear is minor, file the bottoms of tie straps and cutters square. If wear is extensive, replace the saw chain.

Problem:
Drive links wear heavily or break.

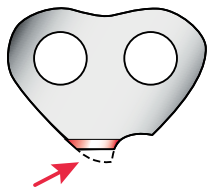

Straight bottoms.

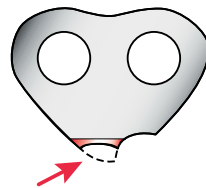

Concave bottoms.

Remedy: Check your guide bar (grooves in guide bar's body or nose have worn too shallow), and check your rim or spur drive sprocket (excessive wear is allowing drive links to bottom out). Replace guide bar, drive sprocket, or both. Sharpen drive link tangs, as shown on page 24, if possible. If not, replace the saw chain.

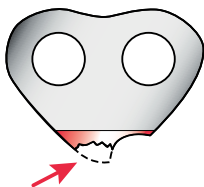

Battered and broken bottoms.

Remedy: Maintain proper tension to prevent saw chain from climbing out of spur drive sprocket. Replace drive links or replace entire saw chain if many drive links are damaged.

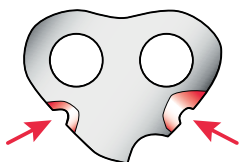

Peening in front or back.

Remedy: Drive sprocket has worn out of pitch, replace it. Replace saw chain. Do not attempt to run a new saw chain on an old drive sprocket, or an old saw chain on a new drive sprocket.

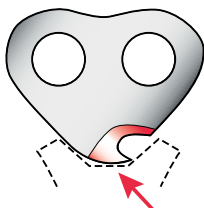

Drive link tang is turned up.

Remedy: Drive link has worn down until drive link tangs hit bottom. Replace drive sprocket. Sharpen drive link tangs as shown in the illustration on page 24 if possible. If not, replace the saw chain.

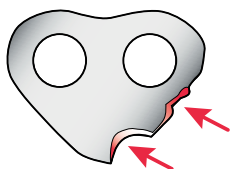

Worn fronts.

Remedy: Remove damage from sides of drive links with a flat file. Sharpen drive link tangs as shown in the illustration on page 24. Use a thin file to open the groove lead-in at the guide bar's tail.

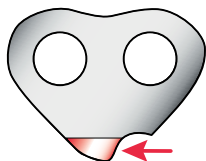

Sides worn round or thin at bottoms.

Remedy: Guide bar rails have spread, or one rail has worn low, allowing saw chain to lean over. Have guide bar rails serviced by a dealer, otherwise replace guide bar. Replace saw chain if wear is extensive or if problem persists. **NOTE:** Also check bottoms of tie straps and tops of guide bar rails.

Saw Chain Troubleshooting

Sharpening drive link tangs

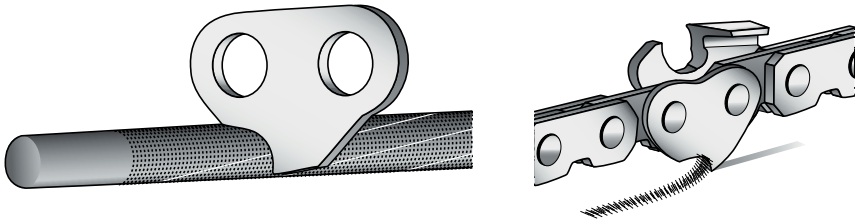

Pointed drive link tangs help remove chips and debris from your guide bar groove. Sharpen damaged tangs back to original shape with a round file.

Problem: **Saw chain has tight joints**

Tight joints are caused by either loose tension or a worn out drive sprocket. Look closely at your saw chain's chassis.

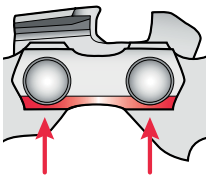

Peening on bottoms of cutters and tie straps.

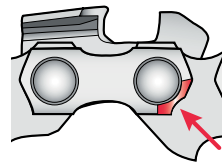

Peening on front corners of cutters and tie straps.

Remedy: Saw chain with tight joints cannot be repaired. Replace the saw chain and maintain proper tension. Replace rim drive sprocket if worn.

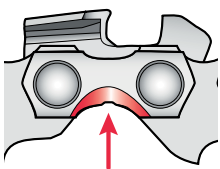

Peening in notches of cutters and tie straps.

Remedy: Replace the spur drive sprocket. Replace the saw chain. Always maintain proper tension and do not run saw chain on a worn drive sprocket.

Problem:
Saw chain cuts crookedly, leads to one side or cuts unevenly.

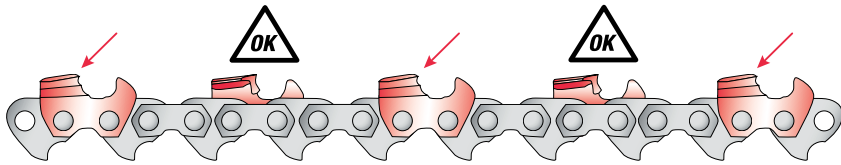

Damage to cutters on one side of the saw chain.

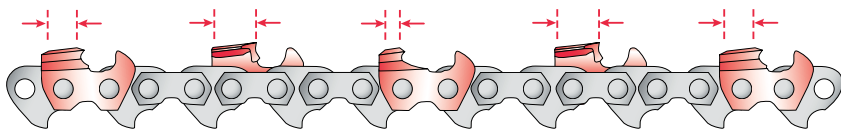

Inconsistent sharpening.

Remedy: File cutters back enough to remove all damage and incorrect angles. Keep cutter lengths and depth gauge settings equal.

i **Carlton® Technical Tip**

If you've tried everything and your saw chain still fails to cut properly, take it to your local authorized Carlton® dealer. They will show you how to properly maintain your Carlton saw chain for the best results and the longest saw chain durability.

Guide Bar Types

Carlton® guide bar types

Consumer Bar

Safe Tip™ • Laminated



Semi-Pro Bars

Semi-Pro Tip™ • Laminated • Small radius, 3/8LP-9T

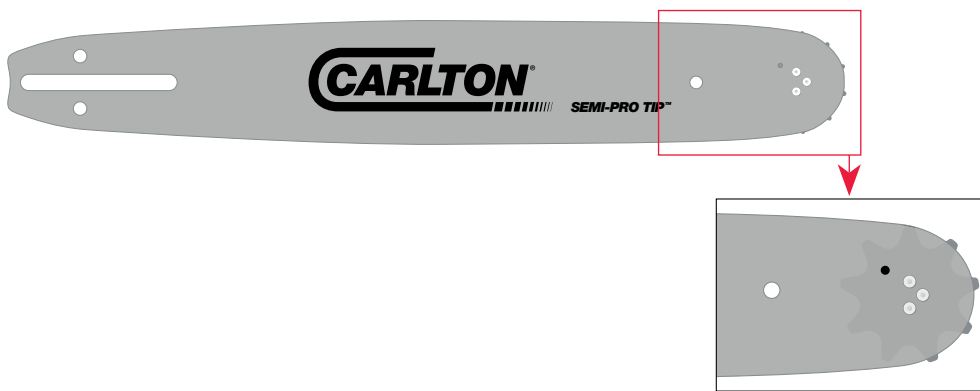

Semi-Pro Tip™ • Laminated • Small radius, 325-10T



Semi-Pro Tip™ • Laminated • Large radius, 325-12T, 3/8-11T



Pro Bars

Super Pro™ • Laminated • Small radius, 325-10T

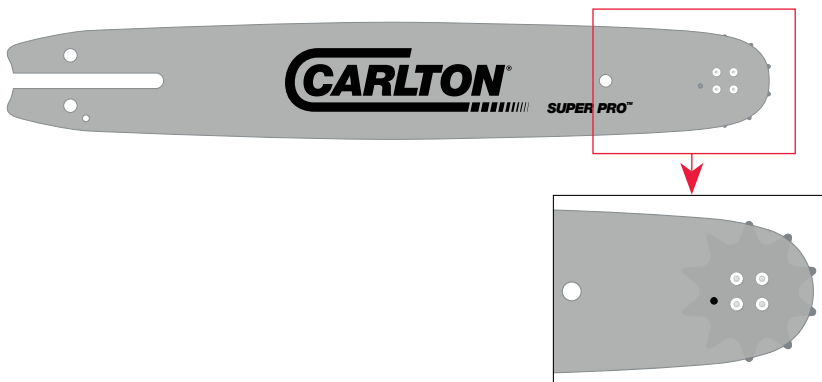

Super Pro™ • Laminated • Large radius, 325-12T, 3/8-11T



Speed Tip™ • Solid • Large radius, 325-12T, 3/8-11T



Dura Tip™ • Solid



Guide Bar Types

Guide bars are intended to serve as their name implies; to guide the saw chain. Guide bars are **never** to be used as a pry bar, anvil or felling wedge.

As with saw chain, many common guide bar complaints are a result of poor or improper maintenance.

Solid nose guide bars – professional use



Solid nose guide bars are made from a single piece of steel with hard facing materials welded to the nose area. Solid nose guide bars are not intended to be used in an application that requires a lot of bore-cutting or extensive cutting with the nose portion of the guide bar. Solid nose guide bars are best in gritty cutting conditions, such as cutting up fallen trees, as they have no bearing in the tip. They are more expensive to replace, so avoid using them where the tip of the guide bar is used extensively.

Sprocket nose guide bars – professional use



Sprocket nose guide bars are designed for the very applications where the nose portion of the guide bar is used in cutting. These guide bars have a series of needle bearings inside a sprocket, laminated at the tip. In bore-cutting, this bearing assembly takes the friction from the saw chain away from the body of the guide bar. Sprocket nose guide bars enable the user to replace just the sprocket nose, rather than the entire guide bar. Sprocket nose guide bars are the best for all-around cutting.

Laminated sprocket nose guide bars – consumer use



These guide bars are made from three layers of steel assembled and spot welded. Laminated guide bars are usually the most economical option, and are a great choice for occasional and semi-professional use.

Guide Bar Components and Maintenance

Guide bar components

Guide bars are made of specially tempered steel. The rails of the guide bar on which the saw chain runs are hardened to specifications that have proven to offer the best durability in a variety of cutting conditions. Under normal use, when saw chains are properly maintained, a guide bar should last through several saw chains.

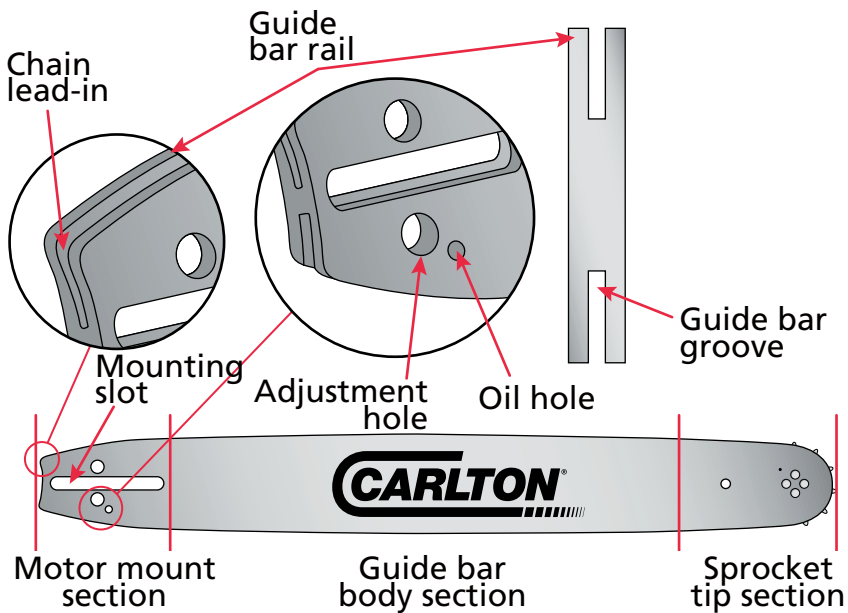

Guide bar maintenance

Although guide bars require very little maintenance, it is essential to periodically inspect the guide bar to ensure the rails are square, no burrs appear on the rails and check that the oil holes and grooves are free of sawdust and grit that might restrict lubrication.

Carlton® suggests using a **bar groove cleaner** to keep the guide bar rails clean.

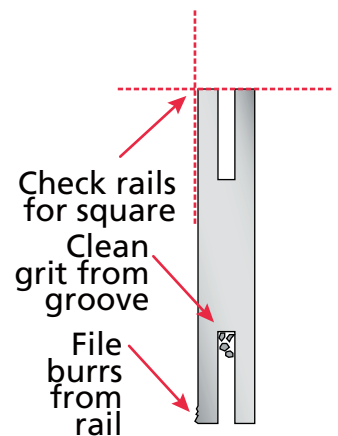

Lubrication

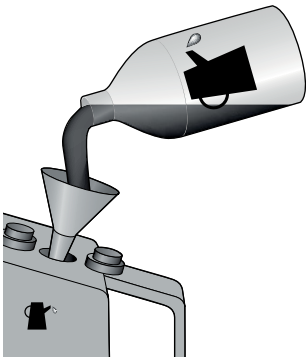

Use good quality guide bar and saw chain oil.

Turn nose sprocket while pumping grease until the whole sprocket has new grease. Do not push dirt into the hole.

Never use waste engine oil to lubricate your guide bar and saw chain; old engine oil contains grit and acids that can harm the chain saw oiler and it will increase guide bar and saw chain wear.

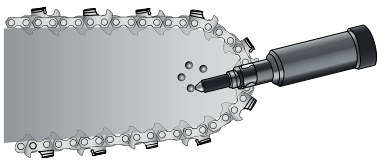

Proper lubrication and maintenance is essential to avoid premature saw chain wear. Wear on the saw chain's drive links and rivets (see illustration) can be avoided by proper saw chain and guide bar maintenance and lubrication.

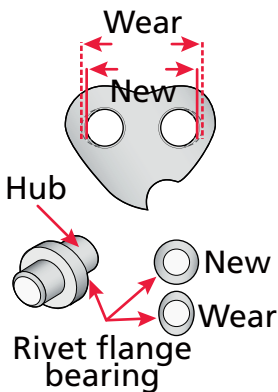

When operating properly, the chain saw should pump enough oil to have some sling off the end of the guide bar. This flushes away grit that could ruin the bearings of the saw chain and accelerate guide bar rail wear. The remaining oil will lubricate the guide bar and saw chain. Please see page 16 to review saw chain tensioning details.

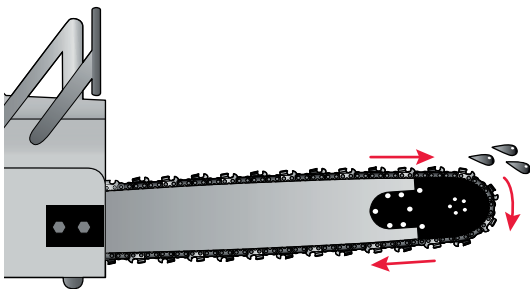

Guide bar problems

Guide bars can fail from poor saw chain maintenance, poor saw chain tension, lack of lubrication on the rails and/or at the tip, or from abuse such as using a guide bar as a pry, a lever, or getting pinched in the cut can cause guide bar failures.

Side view of guide bar problems

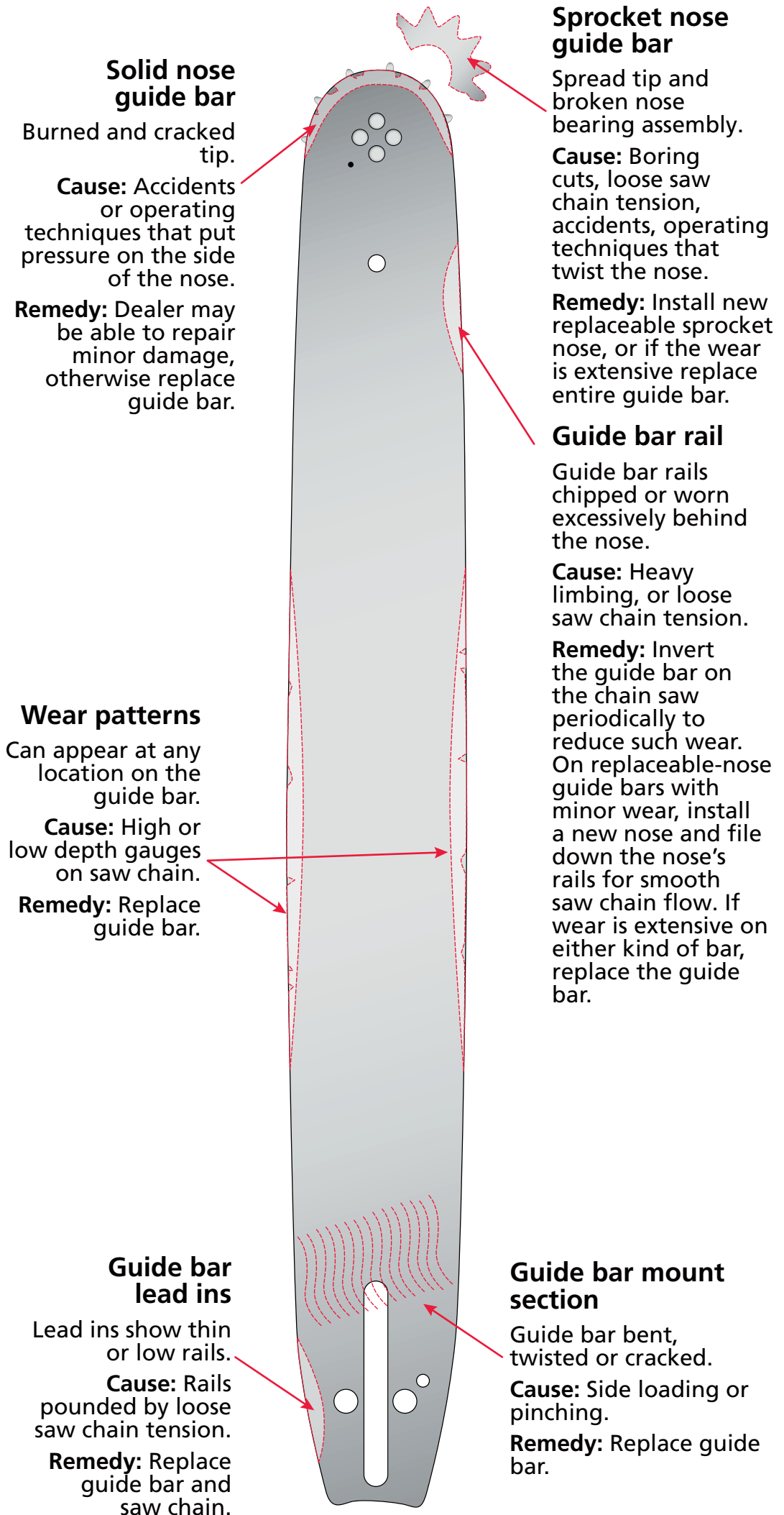

Drive Sprocket Terms

Rim drive sprockets

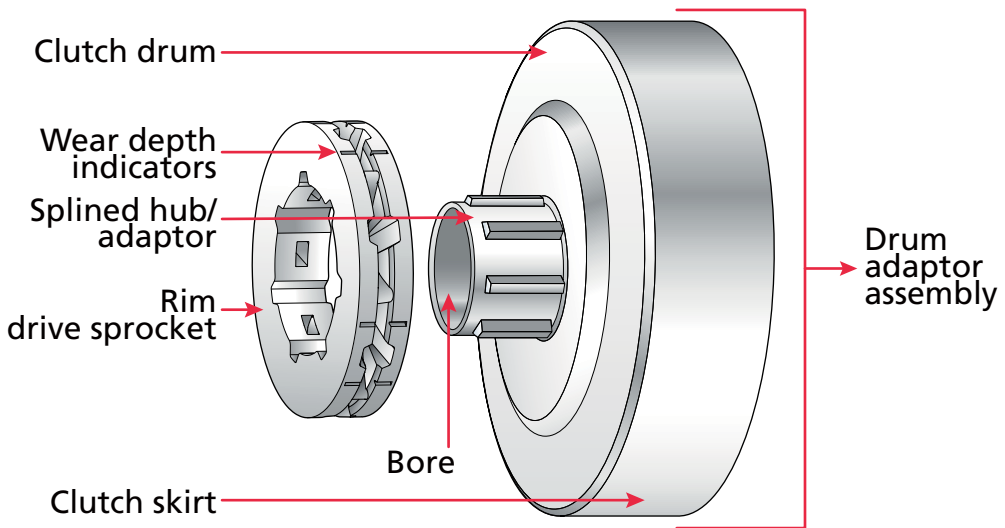

Spur drive sprockets

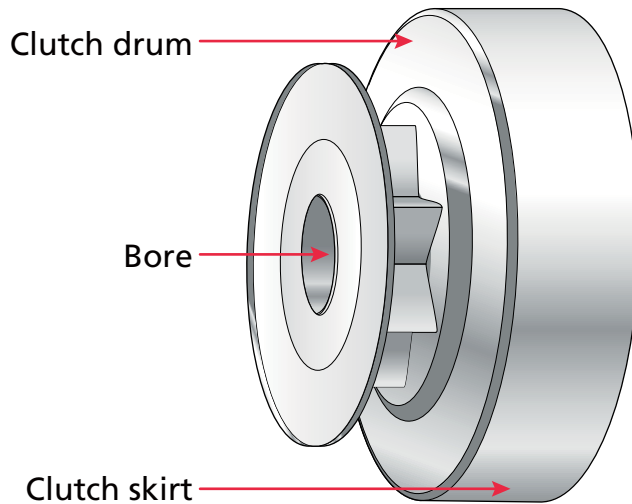

The power from the chain saw's engine is transferred to the saw chain through a centrifugal clutch and drive sprocket. Chain saws use two types of drive sprockets: **Rim drive sprocket systems** and **spur drive sprockets**.

A **rim drive sprocket** is a two piece unit that allows you to replace the rim on the drum adaptor assembly as the rim wears out.

A **spur drive sprocket** incorporates the centrifugal clutch drum and drive sprocket into a single piece and must be changed as a complete unit.

Drive Sprocket Maintenance

Regardless of which design you favor, there are two things you need to know about drive sprockets:

1. The drive sprocket pitch must match the pitch of the saw chain and guide bar (sprocket nose guide bars).
2. The drive sprocket must be replaced when it's worn out.

The saw chain and drive sprocket are a matched set, just like two gears working together. As the saw chain wears out, the drive sprocket also wears out.

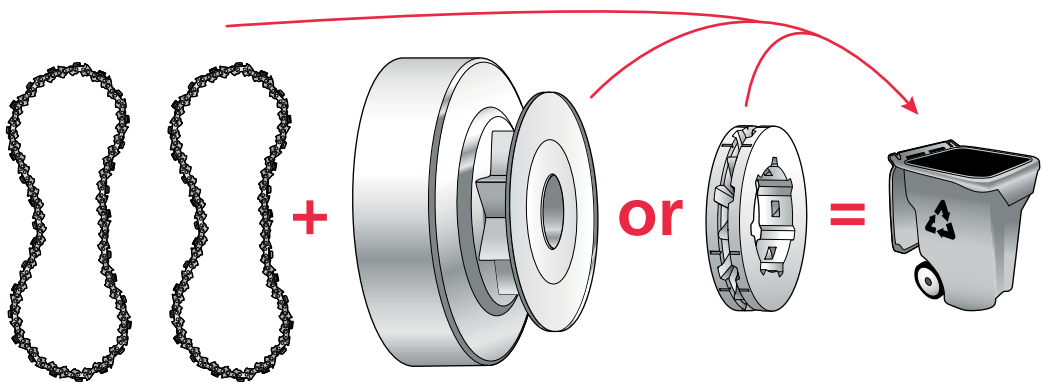

Never run any saw chain on a worn drive sprocket rim or spur system, especially a new saw chain. Replace your rim or spur system after every two saw chains, or sooner.

Drive Sprocket Maintenance

The kinds of problems that worn or improper-pitch drive sprockets create make it worth checking every time the saw chain is replaced. A new saw chain can be ruined if it's installed on a worn rim or spur drive sprocket. Check the wear on your drive sprocket before each session use. If worn, replace the drive sprocket before installing a new saw chain. In abrasive conditions, wear will increase. Here's what to look for:

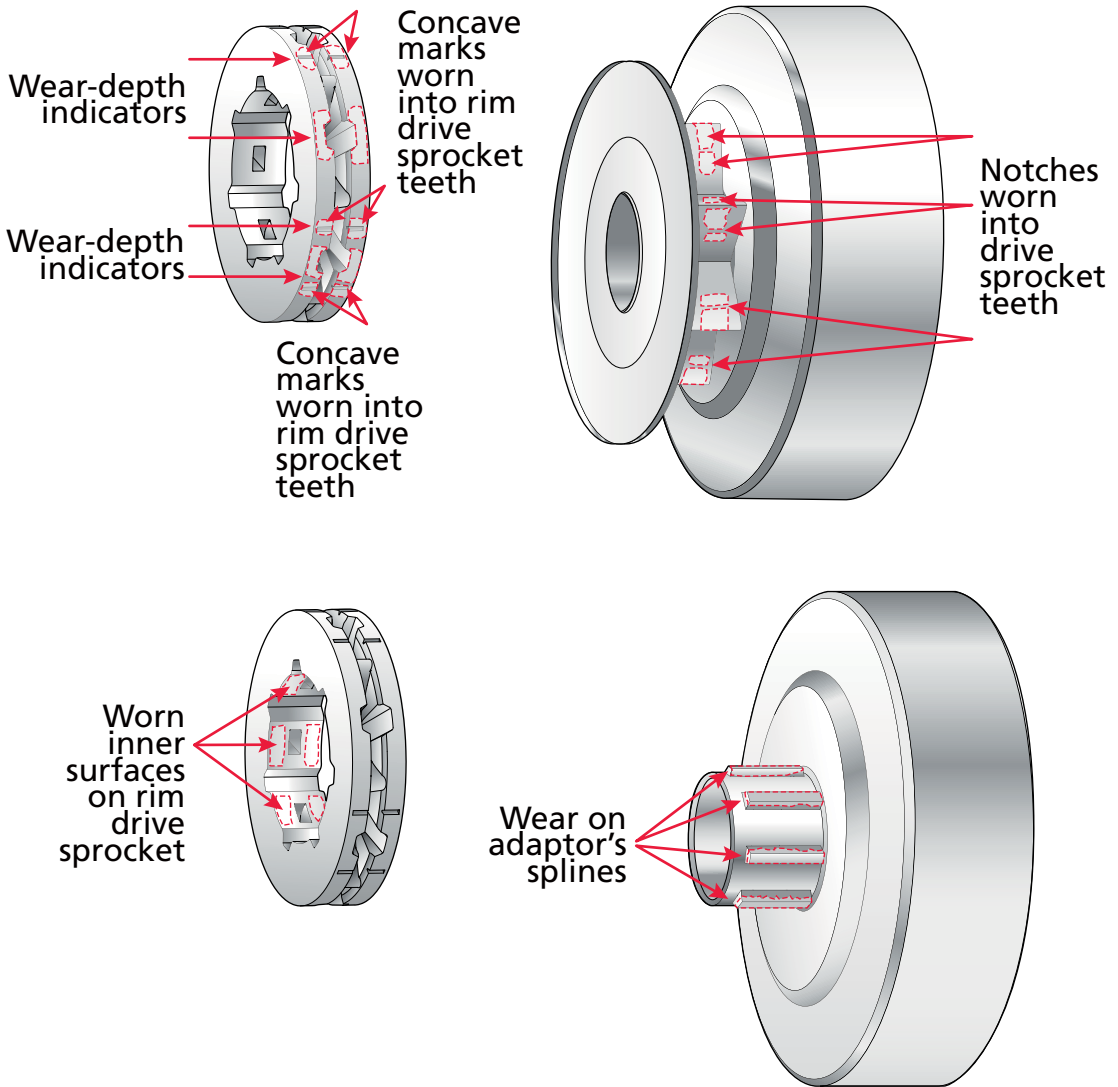

Drive Sprocket Maintenance

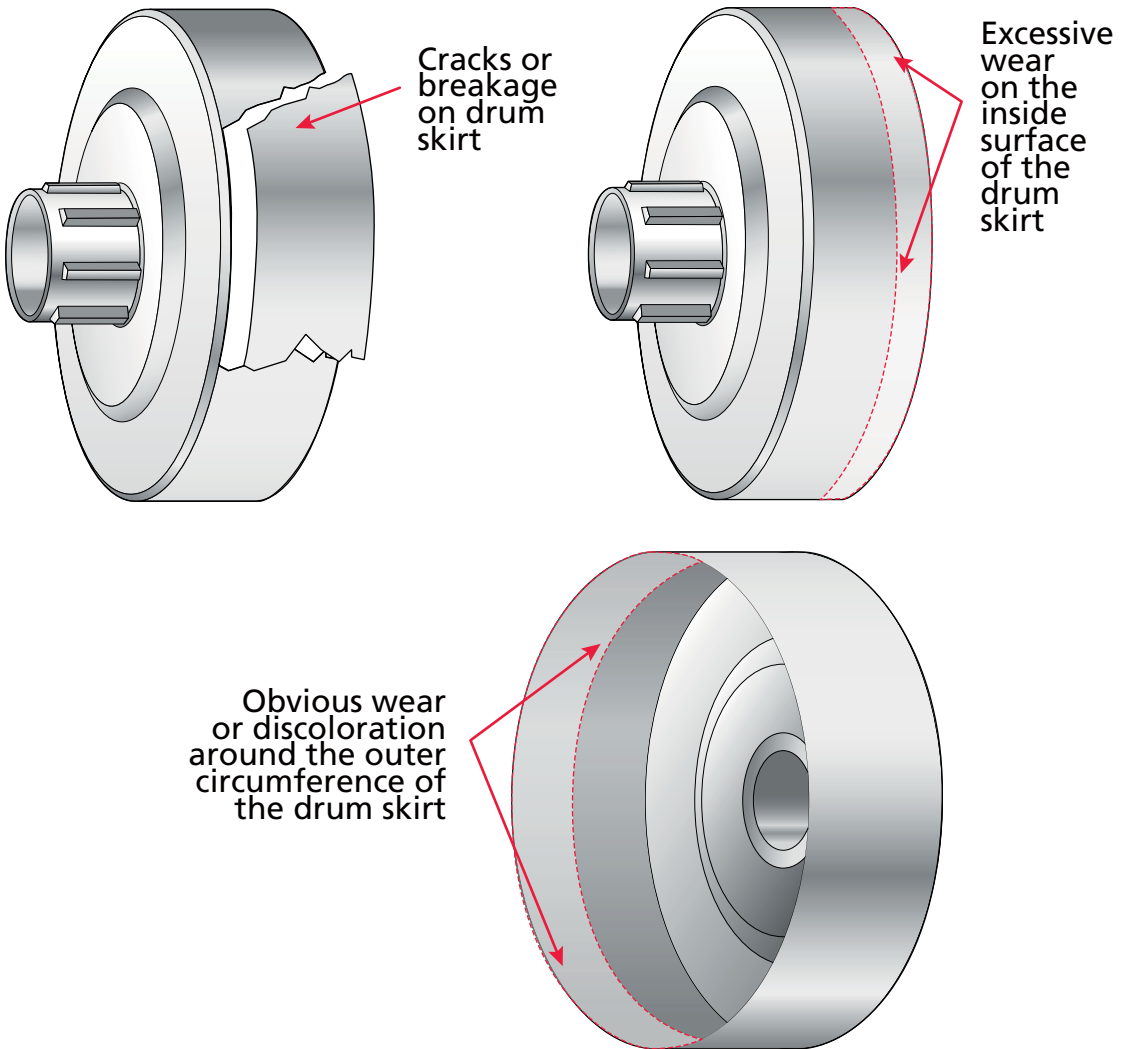

Remember these points:

1. Always install a new saw chain on a new drive sprocket, making sure pitches match.
2. Periodically check drive sprockets for wear.
3. Replace drive sprockets at the first sign of wear (see above).
4. A damaged drive sprocket, no matter the amount of wear, cannot be repaired. It must be replaced.

Cutting in Cold Weather

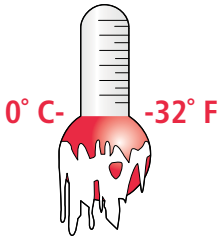

Cutting in extreme cold weather can accelerate all forms of saw chain, guide bar and drive sprocket failures. All steel parts become more brittle and less tolerant of shock loads and stress as the temperature drops below freezing.

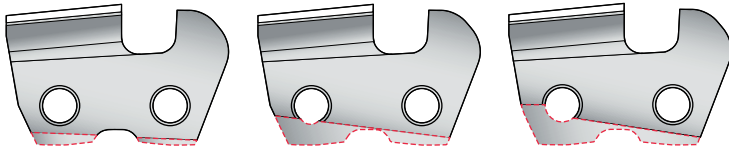

Cutting frozen wood will cause rapid wear and possible breakage around the rear rivet hole of cutters. Follow the steps below to keep cold-weather wear to a minimum.

Oil

Dilute guide bar/saw chain oil 25% with clean kerosene or diesel oil. Use twice as much of this diluted oil during operation, and be certain your saw chain is receiving oil from the chain saw.

Tension

Keep your saw chain correctly tensioned. Check and adjust often.

Saw chain cutters

Keep your saw chain cutters sharp. Touch up the cutting edge with a file every hour, more often as needed. Do not force dull saw chain to cut.

Depth gauges

Check and adjust your saw chain cutters' depth gauges every 3 – 4 sharpenings.

Guide bar

Keep the guide bar groove clean and the oil hole open. Turn symmetrical guide bars over to equalize rail wear.

Drive sprocket

Replace the drive sprocket after every two saw chains, or sooner.