

Installation Instructions

LT35 Hand Tool Rack

for Utility Landscape Trailers

Before you begin installing:

1. Read and understand these instructions completely.
2. Verify that you have received all the parts listed in the bill of materials.

CAUTION

Always wear safety glasses when using power tools.

WARNING

Check under the trailer and/or fender for locations of brake lines and electrical wiring etc., before drilling any holes. Any damage to trailer during installation is installer's sole responsibility.

Tools Required:

- (2) 9/16" Wrenches and/or Sockets
- (2) 1/2" Wrenches and/or Sockets
- Electric Drill
- 13/32" Drill Bit
- Carpenter's Square
- C-clamp

1. Clamp the post of the hand tool rack to the trailer side rail. The hand tool rack uses 4" x 23" of the trailer floor space and the post is centered in this space. Position the hand tool rack such that the lawn mowers or other equipment will not damage the hand tool handles. Verify that the post is square to the trailer deck in both directions with a carpenter's square.

2. After determining the position of the post mark center of the two holes in each upright base on the trailer deck.

3. Remove the post from the trailer and use a 13/32" drill bit to drill two holes in your trailer floor as marked.

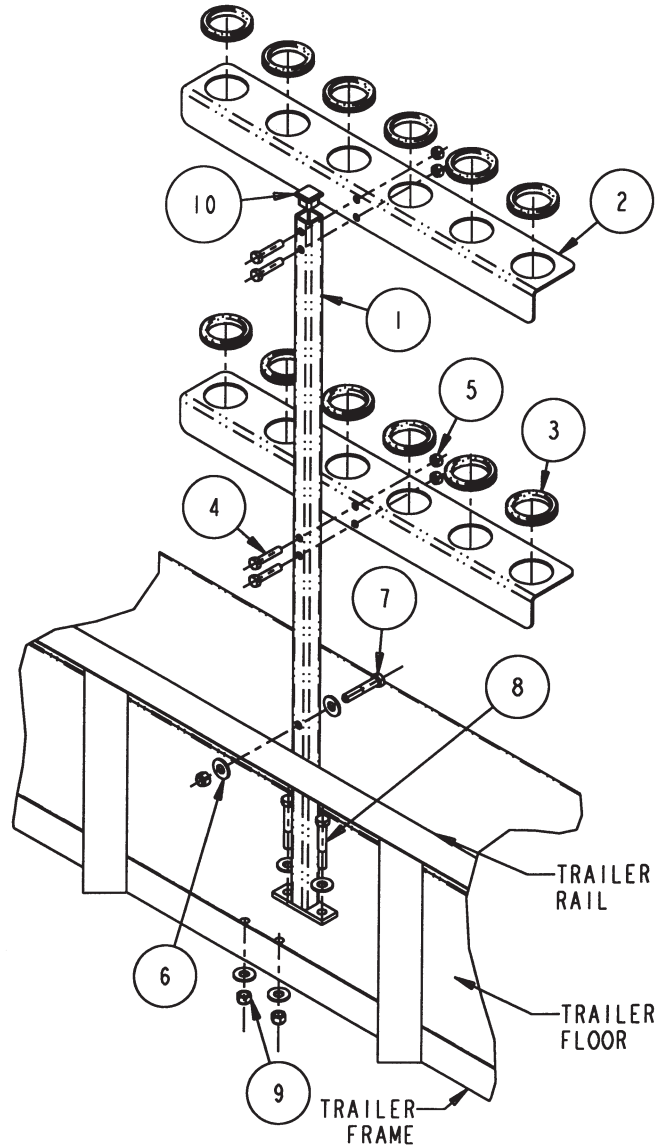

Bill of Materials

ITEM	PART NO.	QTY.	DESCRIPTION
1	3004207	1	Post, Hand Tool Rack
2	3004165	2	Angle, Tool Holder
3	3004167	12	Grommet, Rubber, for 2" Hole
4	-	4	Screw, HHC 5/16-18 x 1-1/2 Gr 5 Zn
5	-	4	Nut, Nylock 5/16-18 Zn
6	-	6	Washer, Flat 3/8 USS Zn
7	-	1	Screw, HHC 3/8-16 x 2 Gr 5 Zp
8	-	2	Screw, HHC 3/8-16 x 2-1/2 Gr 5 Zp
9	-	3	Nut, Nylock 3/8-16 x 7/16 Zn
10	-	1	Plug, Plastic Finish, 1" Square Tube

- 4.** Assemble the post to the trailer with two 3/8-16 x 2-1/2" cap screws, four 3/8" flat washers and two 3/8-16 nylock nuts. **Do not tighten screws at this time.**
- 5.** Clamp the post to the rail of the trailer. Make sure the post is square to the rail and the deck of the trailer with a square.
- 6.** With the post clamped into position, drill a 13/32" hole through the center of the post and the trailer rail.
- 7.** Fasten the post to the trailer rail with a 3/8-16 x 2" cap screw, two 3/8" flat washers, and a 3/8-16 nylock nut. Tighten all three screws.
- 8.** Assemble the tool holder angle brackets to the post using four 5/16-18 cap screws and nylock nuts. The tool holder angles should be above the trailer floor so that the handles of the tools rest on the trailer floor.
- 9.** Assemble the twelve grommets into the two inch holes in the tool holder angles.